

GENESIS

Lunar Outpost

Program/Requirements Document for an
Early Stage Lunar Outpost

Prepared by

The Space Architecture Design Group
Department of Architecture and
Center for Architecture and Urban Planning Research
School of Architecture and Urban Planning
in cooperation with
College of Engineering and Applied Science
University of Wisconsin - Milwaukee

Dino J. Baschiera
Stephen D. Chizzo
Joseph P. Fieber
Hiroshi Hattori
Steven Lerch
Michael R. Kinde
Susan E. Moss
Janis Huebner Moths
Kerry Lynn Paruleski
Stephen B. Schelwat
Curtis W. Schroeder
Steven Skowronski
Brenda Sue Wiegand

Timothy Lee Hansmann, NASA/USRA Teaching Assistant
Edwin G. Cordes, NASA/USRA Instructor
Gary T. Moore, Professor of Architecture/Project Director

Edited by

Dino J. Baschiera
Edwin G. Cordes
Joseph P. Fieber
Timothy Lee Hansmann
Gary T. Moore
Janis Huebner Moths

National Aeronautics and Space Administration
Universities Space Research Association
Advanced Design Program

December 1989

School of Architecture & Urban Planning
University of Wisconsin - Milwaukee



GENESIS: LUNAR OUTPOST
Program / Requirements Document for an
Early Stage Lunar Outpost

Space Architecture Design Group
University of Wisconsin-Milwaukee

ABSTRACT

The second in a series of documents from the Space Architecture Design Group, this report outlines the program requirements of an early stage outpost for the moon. Developed under a three-year grant from the National Aeronautics and Space Administration's Universities Space Research Association (NASA/USRA), the program covers human factors, environment-behavior, structural, materials, construction processes, life-systems, and related processes for an 8-12 person lunar base for crew durations up to 20-month intervals. The program includes sections on base master planning, base operations including command center and all technical support systems, mission operations including laboratories, lunar surface mining, production analysis, construction technology, and other experimental systems, and crew support habitat, and all related design requirements. This document will be useful for students interested in space applications including space stations, lunar habitats, Martian developments, space transport vehicles, etc.

Pp. xix + 89; charts, illustrations, references

PUBLICATIONS IN ARCHITECTURE AND URBAN PLANNING

Center for Architecture and Urban Planning Research
University of Wisconsin-Milwaukee
P.O. Box 413
Milwaukee, WI 53201-0413

Report No. R89-1
ISBN No. 0-938744-61-5

Additional copies of this report are available for \$10.00 prepaid by writing to the above address.

Table of Contents

Preface and Acknowledgments	<i>v</i>
Scenario	1
I. Base Master Plan	5
Master Plan Components	5
Base Layout	6
Transportation Systems/Exterior Circulation and Translation	11
Image	12
II. Base Operations	15
Command Center	15
Intra-Base Communications: Tele-conferencing and Meeting Facilities	20
Logistics Modules/Storage Systems	22
Safehavens/Emergency Systems	23
EVA Chamber	24
Power Systems	29
ECLSS /HVAC Systems	35
Lighting Systems	40
Thermal Control Systems	44
Material Storage Systems	45
Waste Storage Systems	46
III. Mission Operations: Experimental Systems	49
Introduction	49
Laboratories: General Design Requirements	49
Lunar Surface Mining and Production Analysis Facility	53
Construction Technology Testbed	54
CELSS Research Facility	55
Far-Side Lunar Observatory	58
Human Factors and Environment-Behavior Systems Research Facility	59
IV. Crew Support /Habitat	61
General Design Requirements / Introduction	61
Personal Quarters and Associated Components	66
Personal Hygiene Facilities	69
Laundry Facilities	71
Exercise Facility	73
Medical Facility	77
Group Recreation Areas	80
Meals /Meal Preparation Area	83
Design Recommendations Graphics	85
References	89

Table of Figures

- Figure 1: Triangular and Raft Module Configurations (SICSA, 1989)
 Figure 2: Linear Module Configuration (SICSA, 1989)
 Figure 3: Orthogonal Module Configuration (SICSA, 1989)
 Figure 4: Comparison of Tunneling Patterns (MIT, 1987)
 Figure 5: Landing Pad Proximities (Eagle Engineering, 1988)
 Figure 6: Landing Pad Growth and Phasing Diagrams (Eagle Engineering, 1988)
 Figure 7: Landing Facility Components and Dimensions (Eagle Engineering, 1988)
 Figure 8: Landing Pad Surface Finishes (Eagle Engineering, 1988)
 Figure 9: 0 Gravity Sight Reference Changes (NASA, 1989)
 Figure 10: Atmosphere Thermal Comfort Requirements (NASA, 1989)
 Figure 11: Logistics Supply Module Elevation (Alred, 1989)
 Figure 12: Logistics Module Unloading Concept (Alred, 1989)
 Figure 13: Stages of Lunar Development and Power Requirements (Mendell, 1985)
 Figure 14: Regenerative Fuel Cell System Diagram
 Figure 15: SP-100 Nuclear Power Plant Diagram (Mendell, 1985)
 Figure 16: Possible Siting Options for Lunar SP-100 (Mendell, 1985)
 Figure 17: Energy Conversion / Storage System (Mortazavi, 1987)
 Figure 18: Geochemistry/Petrology Lab Module (NASA 84-00653)
 Figure 19: CELSS Design Components and Details (Polette, 1988)
 Figure 20: Table of Plant Growth Characteristics (Polette, 1988)
 Figure 21: Section Through Initial Stage Inflatable CELSS Facility (Polette, 1988)
 Figure 22: Section Through Advanced Stage Inflatable CELSS Facility (Polette, 1988)
 Figure 23: Plan Configuration Concept, CELSS Facility (Polette, 1988)
 Figure 24: Body Inclinations in Various Gravities (Moore, 1989)
 Figure 25: U.S. Male /Female Body Dimensions (Interiors Magazine, nd)
 Figure 26: EVA Suit Dimensions (NASA, 1989)
 Figure 27: Possible Hygiene Facility Layouts - Susan Moss
 Figure 28: Isometrics of Reduced Gravity Exercise Machines - Stephen Chizzo
 Figure 29: Viewing Screens for Exercise Equipment - Stephen Chizzo
 Figure 30: Initial Phase Layout of Exercise Equipment - Stephen Chizzo
 Figure 31: Second Phase Layout of Exercise Equipment - Stephen Chizzo
 Figure 32: Medical Facilities Phasing Diagrams - Stephen Chizzo
 Figure 33: Plan View of Possible Group Recreation Facility - Stephen Chizzo
 Figure 34: Guidelines for Arrangement of Interactive Meetings (NASA, 1989)
 Figure 35: Group Meeting and Minimum Corridor Dimensions (Interiors Magazine, nd)
 Figure 36: Possible Space Station Galley Layout (SICSA, 1989)
 Figure 37: Crew Seating Configurations - Janis Huebner Moths
 Figure 38: Food Storage / Galley Design (SICSA, 1989)
 Figure 39: Functional Groupings to Promote Social Interaction - Janis Huebner Moths
 Figure 40: Lunar Base Proximity Bubble Diagram - Stephen Chizzo
 Figure 41: Noise Gradient Proximity Diagram - Stephen Chizzo
 Figure 42: Approximate Square Footage Alloted per Function - Stephen Chizzo
 Figure 43: Square Footage Variations per Base Phasing - Stephen Chizzo

Preface and Acknowledgments

Since 1987, the School of Architecture and Urban Planning (SARUP) has been involved in space architecture. Our first involvement was the launching of a lunar base studio directed by Prof. Anthony J. Schnarsky with active involvement by Mr. Thomas M. Crabb, then of Astronautics Corporation of America and now of Orbital Technologies Corporation, in which Mr. Edwin G. Cordes was a key graduate student. This was followed by a pair of reports on space architecture by Prof. Schnarsky, Mr. Cordes, and others and by Mr. Cordes and Prof. Gary T. Moore. In the spring of 1989 we were invited to become involved in a multi-university Advanced Design Program sponsored by the NASA/Universities Space Research Association (NASA/USRA). This design seminar/workshop was held under the auspices of this program with partial funding from NASA/USRA.

The purpose of the seminar/workshop on which this report is based was to give students in architecture, engineering, and the social and biological sciences an opportunity to become involved in an exciting, interdisciplinary advanced design program in space architecture for the moon and Mars in conjunction with the US National Aeronautics and Space Administration (NASA). Students learned about the natural environment of the moon and Mars, human factors and habitability, construction technology, energy use, long-range planning, and international politics and law.

In the fall term of 1989, we focused our activity around information gathering and facility programming for an early stage lunar outpost. Areas of investigation included interior space and habitation module design, construction technology, the integration of a complete life support infrastructure, integration of lunar materials industrialization, and energy considerations. The seminar/workshop included lectures by the course instructor, project director, chief consultant, teaching assistant, and guests, readings associated with each topic, facility program development, and two brief hands-on design charettes. The facility program was developed in stages and was used as the programming document for the follow-on spring design workshop/studio. The mini design projects tested the facility program and suggested design ideas to be explored in more detail in the workshop/studio. Over half of the fall class continued, and were joined by new students in the spring design studio/workshop.

The second year of this three-year grant will focus on manned missions to Mars, including energy systems, base expansion and outposts, and surface transportation systems along with habitation issues and the development of a Mars settlement. The third year will focus on the habitation requirements for manned transport systems between the Earth, the lunar outpost, and the Mars settlement. Students may be involved for any length of time including the full three years.

We owe our thanks to many who assisted us throughout the fall semester. First and foremost, those of us continuing with the project owe our greatest thanks to Ed Cordes, the NASA/USRA Instructor. Mr. Cordes began as a graduate student in architecture, graduated with distinction submitting a computer-based thesis on space architecture, and then attended and graduated from the International Space University in Strasbourg, France. He led the project conceptually and intellectually from the beginning, and now leaves the University to assume a position as Design Engineer, Space Station Division at McDonnell Douglas Corporation in Houston. Without his guidance the NASA/USRA grant and this seminar/workshop never would have materialized. We will miss him greatly.

We also owe our thanks to the following: Our Chief Consultant, Mr. Thomas M. Crabb of Orbital Technologies Corporation of Madison; to our Visiting Faculty, Profs. Ryoichi S. Amano, Department of Mechanical Engineering; Al Ghorbanpoor, Department of Civil Engineering; Robert Greenstreet, Anthony J. Schnarsky, and Gerald D. Weisman, Department of Architecture; Umesh K. Saxena, Department of Industrial and Systems Engineering; and to our Visiting Critics, Michael Kalil, Architect, Kalil Studios, New York; Jason Lorandos, Sasakawa International Center for Space Architecture, University of Houston; Ronald R. Teeter, Orbital Technologies Corp., Madison; and Claudio Veliz, Architect, New York. Lastly, we owe thanks to Dr. John Alred, Advanced Design Program Director at NASA/USRA and our program director; Celeste Seychertz-Wilson, our liaison with the Johnson Space Center; and John Connolley, design engineer at NASA/Johnson Space Center and Deborah Neubek, Research scientist at the University of Houston Sasakawa International Center for Space Architecture who gave many valuable suggestions on a draft of this report.

Gary T. Moore
Milwaukee
April 4, 1990

Scenario

The date is 2005. The United States, in conjunction with its space partners Russia, Canada, Japan, a united Germany, and the European Space Agency, has just landed its first team of astronauts, scientists, architects, and engineers to build a permanently occupied habitat on the moon. Called Genesis, this early, phased, and evolutionary outpost will function as a long-term testing ground for all materials, processes, and development strategies to be employed in subsequent exploration of Mars. Information learned from and processes perfected in this base will directly influence the design and scope of the exploration and development of Mars.

Design and development of this lunar test facility was initiated in the year 1989, by NASA and its prime contractors in conjunction with the University of Wisconsin - Milwaukee, Center for Architecture and Urban Planning Research and Department of Architecture in cooperation with the College of Engineering and Applied Science and Orbital Technologies Corporation. The 16 year development time was dictated by the aerospace industry's phased design and fabrication method. This outpost is also reliant on the recently completed cis-lunar transportation system for delivery of all construction elements as well as logistics resupply and crew transfer.

The Earth-Lunar transport system contains a number of key elements including:

1. Recently developed heavy-lift launch vehicles such as the STS (Space Transportation System, ie., shuttle) derived, unmanned Shuttle C with a cargo carrying capacity of 67,500 kg to low earth, space station inclination orbit (28.5° at 220 nmi). The Shuttle C's cargo bay accommodates payloads up to 24.6 m long and 4.5 m wide. Smaller elements will also be launched using other large commercial launch platforms such as the Titan IV which has roughly a 18,900 kg capacity and if necessary other commercial carriers such as the Ariane 5 with a lifting capacity of 20,700 kg and offering the diameter of Shuttle C. A new development cargo vehicle will likely be available by 2005 with a capacity of 50 metric tons but a diameter of 7.6 m and a length of 36.9 m. The Space Shuttle will serve as the primary transport vehicle for base crews to LEO (Low Earth Orbit).
2. LEO Space Station and associated platforms. The Space Station and necessary construction platforms will be used for disassembly of earth launched payloads and reassembling of these payloads onto the cis-lunar transport vehicles. Dedicated crews aboard SSF will perform the required EVA and tele-robotic assembly processes.
3. Cis-lunar transport system. This dual use system will not only transport construction components to the lunar surface but will also ferry crews and logistics to the established outpost. The vehicle will be of a relatively simple design, composed of the transfer vehicle OTV and a separate lander which may or may not be reused. This is a cycling system which reuses a variety of pieces. The second phase cis-lunar system may employ Lunar derived Oxygen (Lunox) as a propellant source.

The physical and environmental characteristics of the lunar surface provide unique design considerations. The atmospheric pressure is virtually a vacuum. The gravitational pull is 1/6th that of Earth's. The lunar magnetic field is $4.4E9$ TESLA/cm³ - approximately $1E - 12$ of Earth's. Solar wind, solar particles, galactic and cosmic rays and high energy particles are the origination of the radiation. Several thousand quakes per year are measured at generally less than 2 on the Richter scale. The largest registered is about 4. The lunar day is 27.4 Earth-days. The temperature variation ranges are -173 C to 92 C (-279 F to 198 F). The Mare regions are plateau like with cratering. The highlands are mountainous regions with craters. Small craters measure <20 km diameter (bowl-shaped), medium craters measure 20-100 km diameter (flat bottomed) and large craters are >100 km diameter (central peaks).

The base will be designed to serve as a research, construction technology, and mining/manufacturing testbed. It will be constructed using cutting edge and evolutionary materials and techniques.

Crew size and duration will also be limited. It is estimated that a full-time crew of 8 to 12 will be common, with the base expanding to 20 persons. Crew duration will vary and be determined by base mission requirements. Six to twelve months at the base would comprise a normal rotation duration, with some crews staying on up to 20 months. Both crew gender and nationality will also vary as the United States invites its aerospace partners to become involved. Gender and nationality differences required careful design consideration for all areas of the base which have human interface, including design issues such as coding, anthropometrics, and wayfinding.

The primary purposes of this first long-term lunar outpost and test bed can be categorized into five major applications:

- 1.Lunar surface mining and production analysis.** A large scale lunar or planetary settlement may require an economic justification for its existence. But a complete economic justification is probably unattainable. Economic potential exists in a number of lunar mining and refinement scenarios, namely Lunar Oxygen or Lunox production, high-leverage technology which greatly reduces resupply costs, and the mining of Helium3, a rare isotope especially suited for nuclear fusion. Experimental systems to test not only the ability to collect the needed raw materials but also to process them efficiently will be a key component of this first lunar outpost. Full production will probably not occur for 5 to 10 years after the first landing.
- 2.Lunar construction technology and materials testbed.** Future base construction will involve the use of both exotic materials and high technology construction methods. Economical lunar development will also involve the use of in-situ materials to some degree. Obvious areas of construction research would include: inflatables, deployables, waste containment systems, the use of lunar regolith for radiation shielding, lunar glass, concrete and sintering techniques among other topics. Methods of construction will also be studied. Lots of work will be required in construction methods and vehicles. Advances in tele-robotic systems, lunar transport vehicles and extra-vehicular activity (EVA) systems will also be evaluated.

3. **Closed system ecological support test facility.** Experimental subsystems integration into a mature base will involve evaluation and determination of potential hazards, for efficient operation. Experimental subsystems such as Closed Environmental Life Support Systems (CELSS) employing chemical regulation methods and Biospheres which depend on biological cycles will be tested as small working prototypes for their possible inclusion in a second generation base at a much larger scale. Alternatives for other subsystems such as power (Nuclear SP-100) or communications will also be analyzed.
4. **Lunar far side observatory.** Astronomical research will also play an important part of this first lunar outpost. A lunar observatory will be established to take advantage of the interference free radio environment found on the far-side of the moon. The radio telescope will serve as an addition to the growing space based great observatories program which includes the LEO Hubble and Gamma Ray telescopes. Operation and monitoring of the telescope will be controlled from the base, or from Earth, and the facility will be visited by astronauts only for routine service or repair.
5. **Human factors and environment-behavior research facility.** Continuing research into the physiological and sociological effects of a closed 1/6th gravity environment will allow designers to refine interior systems and components for a second generation base as well as develop parallels for a future Martian outpost. Facilities used in the evaluation will include specialized anthropometric testing facilities to study human performance in 1/6th gravity as well as physiological changes monitored through the health maintenance facility. The crew's daily interaction with the various base components will serve as the primary evaluation technique. Environment-behavior research will include ongoing post-occupancy evaluation (POE) of the base elements.

Timelines for base development include early unmanned logistics and construction supply missions and 14 day test missions. Current phasing schedules assume a delivery rate of 4 to 8 OTVs per year. According to this estimate it will require approximately 2 years of un-piloted sortie and manned short duration missions before base development will be sufficient enough to support long term habitation.

Mission lengths will gradually increase from 3 months to 1 year as research demands increase and the base reaches full scale operation. It is projected that it will take approximately four years to reach this point in the base development which will be referred to as the initial operating configuration (IOC) with a steady state of at least 12 people. Further base development will occur over much larger period of time and in a phased manner.

Initial lunar surface missions will include the unmanned delivery of consumables and logistics items as well as lunar construction vehicles including a pressurized transport vehicle and Crane. The crane will be used to unload all future supply vehicles and to construct the permanent lunar base. Roadways and landing facilities will also be cleared of obstructions. Major base subsystems will also be delivered prior to the initiation of human tended missions. These systems would include power generation and regulation, heat radiation, launch and landing navigation equipment, and basic base construction elements.

The earliest manned missions will last up to 14 days. The astronauts will live inside their lunar landing vehicle and spend much of each day performing extra vehicular activities (EVA) involved in the base construction. Subsystems will be assembled, activated and connected to the base. Unpressurized storage facilities will be erected to protect the tele-robotic and service vehicles and the site will be prepared. Alternatively, lunar craters and lava tubes may be used for this purpose. Once all the base elements are in place, the pressurized volumes will be protected from radiation and micrometeorite damage through the placement of a protective lunar soil or regolith covering.

Following the completion of the major base elements, the base and its subsystems will undergo a longer test period lasting up to three months. Once all systems and backups have been verified, long duration habitation of the base will begin. Once IOC has been reached, crew change-out will occur every 9 months to a year.

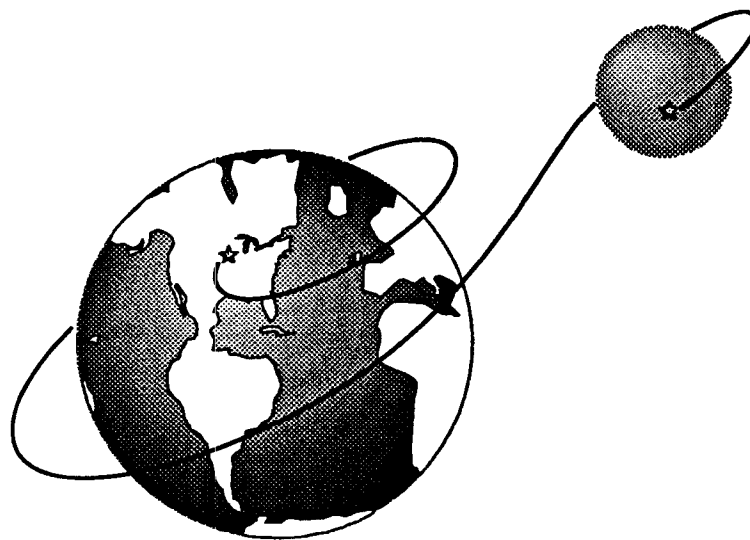

I. BASE MASTER PLAN

A. Master Plan Components

1. Crew Support Habitat

Facilities for the support of crew members and their activities will form the main focus of the base. This area consists of living quarters, work spaces, communications, laboratories, etc.

2. CELSS/Horticultural Research Lab

The Closed Ecological Life Support System will be a study of an almost entirely closed cycle of food and waste management. It will serve as a prototype for a mature lunar base as well as space stations and a Mars outpost. An efficient environmental support system will reduce reliance on outside sources of materials and thereby lower the cost of running a manned off-world facility. Beyond its purely technical considerations it may also serve as a place for crew members to relax.

3. Launch and Landing Facilities

Launch and landing facilities will consist of several remote landing areas that have lander servicing equipment and crew/payload transfer systems.

4. Base Garage and Maintenance Facilities

This area is used to store and maintain vehicles when they are not in use as well as repairing damaged equipment. It may consist of a large non-pressurized hangar but may also have a pressurized area for more delicate repairs. It should be expandable and flexible.

5. Transportation Systems

Surface transportation is needed to travel between some the more distant base elements as well as transferring payloads or crew from one area of the base to another. The transportation should be compatible with all possible payloads and it should be adaptable to many tasks.

6. Mining Surface and Production Analysis Operations

The use of lunar resources will help provide economic incentive and leveraging, for the lunar base. The mining and refinement of metals, isotopes (Helium-3) and other materials (oxygen) are some of the processes that will take place and experimental systems to test methods of collecting and processing lunar raw materials will be an important component of the lunar base. This area will have special power needs and will have other location requirements in relation to the remainder of the base.

7. Construction Technology Test-bed/Tele-robotic Research Laboratories

Some initial phases of base construction will involve high-technology tele/autonomous robotic techniques. Later phases of base construction will involve the use of exotic materials and high technology construction methods as well as in-situ materials for economical lunar development. Construction research will study these new materials and construction methods as well as advances in tele-robotic systems, lunar transport vehicles and EVA systems.

8. Power Plant

There must be a dependable source of adequate power on hand at all times and it is likely that several redundant systems will serve the early lunar base. Some the possible power sources include nuclear power (SP-100), solar power, and fuel cells. Alternatives sources will be studied for effective use in future developments.

9. Lunar Farside Observatory/Science Base

Astronomical research will have an important role in the lunar base. An observatory on the farside of the moon will be free of radio interference and greatly increase the abilities the the present earth-locked research programs. Operation and monitoring of the equipment will be controlled from the base while servicing or repair will necessitate a visit by an astronaut.

10. Human Factors and Environment-Behavior Systems Monitoring Center

The study of the psychological and sociological effects of living in a remote closed environment will help refine base systems and components for a second generation lunar base as well as other off-earth outposts. The evaluation of the needs of the crew will take place primarily through daily interaction with equipment and a post occupancy evaluation (POE) of base elements.

11. Safe Havens

An area designated as a safehaven serves the base in case of an emergency or failure of the main habitat. It should be either easily isolated or physically separated from the rest of the base and it should contain everything the crew might need until a rescue attempt can be made. This would include food, water, communications, limited hygiene, EVA, ECLSS, shielding, etc.

12. Logistics or Materials Storage

Many elements of the lunar base need some form of storage to organize and protect materials and equipment. Both incoming supplies and outgoing materials as well as spare components and waste materials need to have an area designated to house them. This area should be easily expandable and adaptable and it should be easily accessed by members of the crew. At least one of these structures should be near the arrival and departure area.

13. Communications Equipment

Provisions will beed to be made for onmi-directional antenia, radar dishes, etc.

B. Base Layout

1. Module Configuration

The early stages of lunar development will be very dependent on earth launched supplies including most of the habitable structures. These modules (or inflatables, etc.) and their corresponding connecting nodes will limit the configuration to one which is economical and transportable. The primary issues for the configuration are separate, isolatable volumes, dual egress, phased growth, and modularity. Another factor to consider is keeping the early stage simple to allow for the limited construction capabilities of an early lunar outpost.

A. Dual Egress:

Separate, isolatable volumes and dual egress allow a crew member to exit a module in an emergency and it also allows complete circulation throughout the habitat in case one area is damaged or unusable.

B. Phased Growth:

The base elements will arrive from the earth at different times so they should not require additional units for complete usage. They should also function as an entire base when all of the elements are in place. Phasing the growth of the lunar base will require a configuration that provides for these needs as well as possible future expansion.

C. Modularity:

A limited number of module types lowers the cost of the base through standardization and length of on-site construction time. Unique elements require special systems and increase time and money spent on development.

D. Simplicity:

Lunar construction at this early stage may restrict structures to the two dimensional lunar surface. "Second floors" and "basements" require additional machinery which may not be justifiable until a later period of development. Generally, simple designs are more cost effective and easier to employ. Alternatively, there is a possibility of limited use of lunar lava tubes, sub-surface construction, etc.

Some possible geometric configurations that involve the use of a single module design are triangular, "raft," linear, and grid. The different configurations all have positive and negative aspects to them:

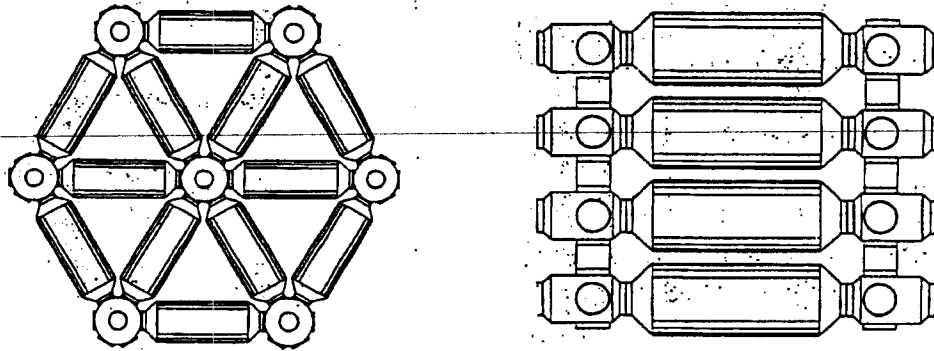

(References for all Figures are given in the table of Figures at the front of this document.)

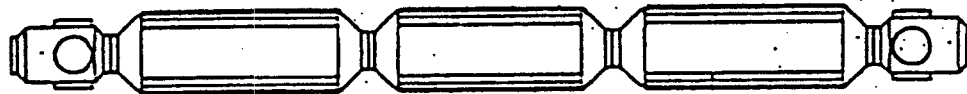

*The triangular configuration allows for dual egress and uniform growth but the nodes become complex and exits are far from some points of the base.

*The raft allows dual egress but requires many nodes.

*The linear configuration has low numbers of nodes but limited circulation.

*The grid or orthogonal configuration appears to offer a good combination of dual egress, uniform growth, easy implementation and standardization, but requires four to complete the configuration.

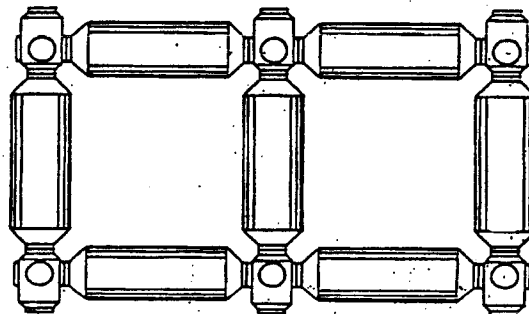

A composite configuration would combine some of the positive aspects of several different geometries (SICSA, 1989).

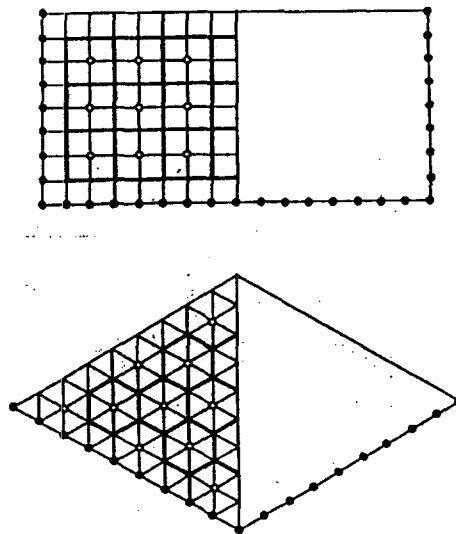

Different construction methods are likely suggest different configurations. Tunneling, for example, would not be dependent on modularity but the pathway and efficient use of tunneling machinery.

The use of craters, lava tubes or other physical features of the moon would result in a configuration dictated by lunar geography. This would give a natural ordering system to follow in the same manner in which towns on earth form around lakes, rivers, etc.

The psychological health of the crew should also be considered in the overall arrangement of the habitat. Modules will quickly tire the mind ("visual landscape"). A larger length and width habitat is required for long-term psychological health. There should be public and private areas outside of those areas designated for meetings and private quarters. One centralized area would provide a physical focal point for the base which could correspond to some key activities of the base. A large public area with semi-public and private spaces nearby would lower the feeling of living in a collection of identical modules. It might also be helpful to have a rest area that would have reminders of earth. Such an area could simply be the biosphere with special additions such as benches or a trellis to remove the feeling of confinement in a human made environment.

2. Efficiency/Organization of Exterior Elements

The overall layout of the lunar base should reflect an organizational idea or geometry that allows the base to be understood functionally as well as used efficiently. Several ordering principles are inherent in the functions that make up the base. The functions of the base include living, science and utility, transportation, industrial, and power production(nuclear). The relationships of these functions to each other will help determine the shape of the base.

Science and Utility:

A science and utility area consisting of a solar power array and an observational science facility will need to be separated from dust producing activities; 10 km plus or minus 2 km should be sufficient with no atmosphere to move dust (SICSA, 1989).

Launch and Landing:

A launch and landing facility should be located in proximity to the areas of the base that it would most frequently serve such as the habitat area and industrial area. This proximity should be subservient to any safety requirements. The distance to the nearest critical element is still questionable. Probably 2-5 km for blast effects. Distances must also keep "walk-back" requirements in mind. Crew must be capable of EVA transfer to excursion vehicles without working rovers.

Industrial:

An industrial grouping which includes mining, power plants (radiators of nuclear plants must also be protected from dust), and manufacturing/processing should be located with regard to the safety and proper functioning of the other base elements. Eventual needs for transportation of lunar materials or products off-planet should be considered. One possible long term scenario might include the construction of a second launch and landing facility or a linear accelerator.

Base Garage/Maintenance:

Individual zones may each require hangers, servicing areas, and materials storage areas, but that may prove impractical at early stages of development. The base garage and maintenance facility will serve as a focus for repairs and storage of transportation equipment and it should be located so it is accessible to all zones of the base until each zone has its own limited facility.

Roadways:

Organized roadways between all segments of the base would allow for efficient transportation of materials and crew while also giving the base some structure.

3.Safety

Launch and Landing :

The basic orientation of the base on the surface of the moon is determined by the link between the lunar surface and the earth. The lunar landers must descend from lunar orbit and have a clear path to the landing pad. By orienting the major base axis north-south (perpendicular to the standard lander orbit) and placing the landing area at one end of this axis, no component of the base would be endangered by an approaching lander or by a lander which overshoots its objective. The distance from the launch and landing facility to other parts of the base should be about 3-5 km to eliminate the amount of blast damage done to the rest of the base. This distance may be as little as 2 km with "blast shields" (Eagle Engineering, 1988).

Power System:

The power supply for the base is of extreme importance for base survival and it should be located far from the launch and landing facility. The power system should also be placed far from the habitation areas so accidents will not endanger crew members. A linear relationship of these two components and the habitat area would satisfy the distance requirements.

Safe Haven:

A safehaven should be accessible from all points of the base but its closest proximity should be to that of the crew habitat. It should be remote enough from the remainder of the base so that no accident at the base affects it adversely. Care should be taken to maintain the safehaven and equip it with appropriate supplies. It is envisioned that the base will be designed with separately isolateable areas for redundant safe havens. A micrometeorite penetration of a module would allow only

seconds to minutes to find safe haven. Power supply, EVA chamber, and ECLSS should all be separate from the main base facilities. Since the very early stages of the lunar base require such a self-contained module for use as a construction shack, it may be possible to outfit it for such a role.

4. Wayfinding

A regular pattern to the lunar base will be important psychologically. A grid or axis that is easily understood even at the large distances required for a lunar base will allow for easy orientation in relation to the base and the moon.

5. Future Growth

The future expansion of the lunar base will depend upon the success of the many different elements that make it up. Long range planning would allow for the expansion of each of the different zones without the loss of efficiency or safety. There should be areas around the main section of the base that can absorb a growing number of habitation sections and other facilities that might be required. A linear arrangement of the lunar base components would allow expansion of the transportation and industrial areas along the major base axis and expansion of the living area along a minor axis perpendicular to that major axis.

~~As the base expands it may also be required to alter the use of various sections of the base.~~
A flexible system that could be rearranged or renovated would be useful. This would be "zoning" in its highest form.

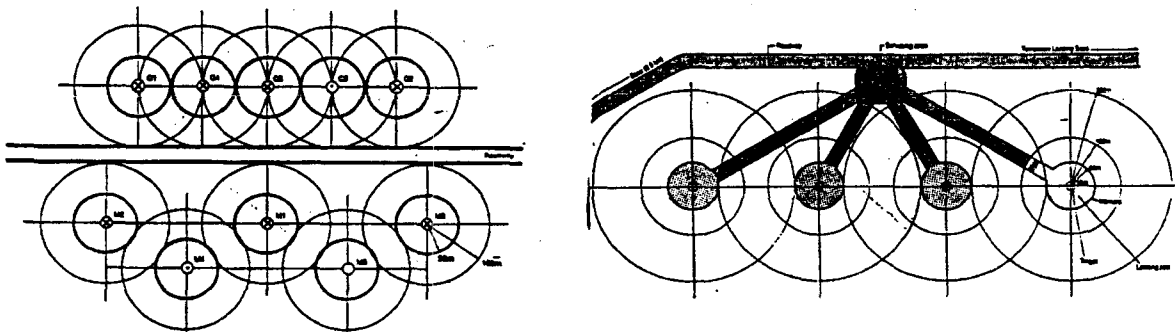
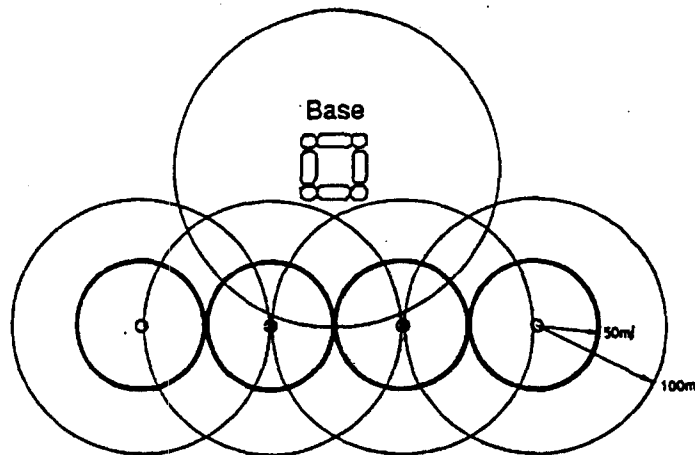

C. Transportation/Exterior Circulation and Translation

1. Phasing

As the lunar base develops, the needs for launching and landing facilities will change. The very early stages of the lunar base will require landing sites near the base. This stage will end with the first manned occupation of the base. It would be very efficient if the landers involved in the early stages could be reused or recycled.

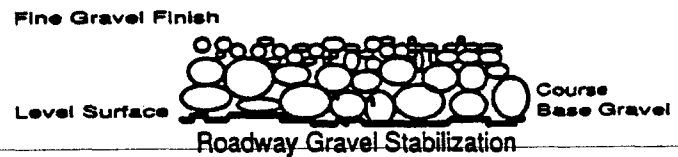
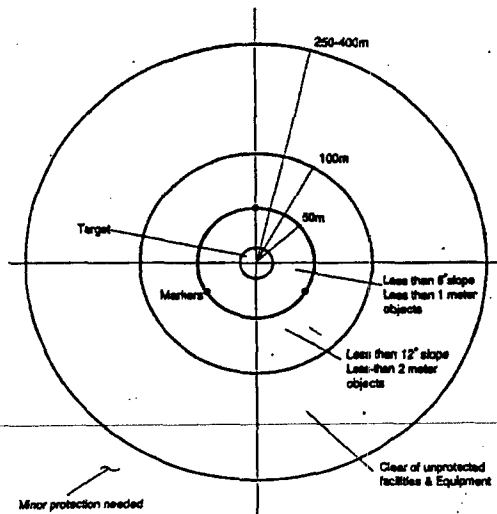

After the first manned occupation, the landing facilities will need to be moved to a more remote location so that the base is neither endangered nor does it suffer blast damage. These temporary sites should be more than 3-5 km from the base and should allow for permanent launching and landing facilities closer to the base but still at least 3-5 km away (Eagle Engineering, Inc., 1988).

2. Safety

Launch and Landing Facilities:

The lander's orbit should not pass over any portion of the base and the landing facilities should be separated from the other facilities by at least 3-5 km (Eagle Engineering, 1988).

Landing Pads:

The individual landing pads should be separated from other equipment by 250-400m to prevent blast damage and the surface of the pad should be free of objects for about 100-200m around the target area. The actual target area should be about 50m in diameter and the surface should be level (slope no greater than six degrees, ideally less than two degrees). Surface stabilization may be considered to minimize dust. Markings and navigational aids will increase the accuracy of manned landings and allow for the possibility of unmanned landings. Until highly accurate unmanned landings are possible it may be necessary to have two separate facilities in the event of an accident. Unmanned facilities could be located farther out along the base axis near the early temporary landing sites (Eagle Engineering, 1988).

3. Proximity in Emergency

Surface Transportation:

Surface transportation should be capable of removing the crew to either the safehaven or to the launch and landing facility in an emergency. Rapid evacuation would require the use of a large pressurized transport to eliminate EVA preparation time. This could also serve as surface transport in non-emergency situations. Examination could be given to methods for pressurized crew transport from habitation areas to landers.

Crew Emergency Rescue Vehicle (CERV):

A CERV could be located at a point in close proximity to the habitation area. An alternative would be a spare lander at the launch and landing facilities. This equipment would need to function reliably in an emergency (NASA, 1989).

4. Protection/Maintenance of Equipment

Surface equipment should have some form of blast protection and, if something remains on the surface of the moon for extended periods of time, it should have some sort of protection from the lunar environment and micro-meteors. This protection could be in the form of an actual shelter or a blanket placed over the equipment. The solution for this problem should be relatively simple to allow for easy crew access and to insure its regular use. In the case of actual repairs, the base garage and maintenance facilities should be adequately equipped to repair all of the necessary systems.

5. Low Manpower Requirements

The movement of crew, payloads and equipment should tie-up as few man-hours as possible. Easily used transportation systems eliminate the need for large groups of people working on a single task and would help lower mistakes under stress. A pressurized transportation system would eliminate the time it would take to prepare for EVA.

6. Flexibility

The transportation systems used for the lunar base should be highly adaptable to many needs. Modularity or the ability to add specialized equipment to a standard platform would lower the amount of space needed to bring the system from the earth.

D. Image

1. Public Face

a. Acceptable appearance from Earth's surface

Considerations should be made as to the visual effect a lunar base will have on the moon. Actual physical features will not be a problem of the early moon base, but it is possible that base lighting will be visible from earth during the lunar night. It is also possible that orbiting debris or dust will alter the familiar view of the moon. This visible evidence of lunar occupancy would not be viewed by all equally and a proper approach at the outset of exploration will lesson conflicts in the future.

b. Acceptable appearance from transmitted images

The lunar base is symbolic of a number of things to people not directly involved with the space program. It will hold a special place in the solar system as the first outpost on another world and should therefore reflect positive qualities of the nations involved. A configuration that is well organized and pleasing will suggest intelligence and forethought as well as goodwill and a sense of unity.

2. Recognition/Icon

Part of the acceptability of the lunar base's image will be the ability of people to recognize it as a human place. Visual cues can help identify the lunar base as a village, outpost, or home and not simply a collection of space hardware. A simple gateway on the path between the landing area and the rest of the base or a symbolic entry way in front of the EVA/base entrance are some examples of small details that would have a large affect on the image of the lunar base. These visual cues relating the base to other known structures may be especially important for the crew by giving them a feeling of security.

Since the entire habitation area of the base will be covered in some form of radiation shielding some, another cue will be necessary to mark the dignified presence of the lunar base. A series of lights on the buildings and along pathways would be a simple method of defining the base and creating a sense of unity among the base elements.

3. Care for Lunar Environment--Lunar "Erosion":

A roadway system on the moon, even if not necessary for vehicular use, would help restrict or at least contain the amount of footprints and tracks left behind by crew members. A "paved" roadway or stabilized surface would lower the amount of lunar dust kicked up by movement throughout the base.

Litter:

A litter clean-up program would eliminate unsightly waste in the base surroundings and perhaps help encourage finding new uses for "useless" items. A careful treatment of the lunar environment will make the lunar base a more pleasant place to work and live in. It will also demonstrate to the earthbound that the nations involved in the lunar base are being thoughtful about future generations of visitors. Selection of materials (food containers, etc.) which could be re-formed for alternate uses will be important. Disposal of spent nuclear fuels will be an issue: burying in place, collecting in one central burial place, or launch into the sun may be options.

Lunar Wilderness Preserves:

Surveys of some areas of the lunar environment should include their designation as wilderness preserves. Untouched regions of the moon will therefore be available for future generations of lunar explorers to view the moon in its untainted state.

4. Unified Image and Character

The lunar base should be consistent in its imagery on the interior and exterior. The overall base ordering should suggest a single organized structure that functions efficiently as a work place and is comfortable as a temporary home. Careful and creative use of space can increase the pleasure of working in the lunar environment and thereby increasing the efficiency of the crew members.

II. BASE OPERATIONS

A. Command Center

Introduction:

The role of the Command Center is similar to that of the human nervous system. It is responsible for the monitoring and control of both primary and secondary base systems and activities. General Base systems design issues include:

- * Life support systems: air quality thermal and conditioning systems.
- * Water systems: Clean water supply and circulation, soiled water return and recycling.
- * Waste systems: waste storage, disposal, and recycling.
- * Communication systems: intra- and inter- base communications, remote antenna control and tracking.
- * EVA/systems: Crew life support and control field monitoring and remote operations monitoring.
- * Robotics systems: Remote drone and ground rover operations monitoring.
- * Emergency backup systems: Emergency sensors monitoring, backup systems readiness monitoring and control.

Design Recommendations:

Although equipment specifications are not currently available, the design of the Control Center should facilitate a monitoring and control environment. A standardized, uncomplicated design would be the easiest to operate and maintain. Simplicity will reduce crew training time, lighten workloads and minimize the potential for error.

1. Anthropometrics / Ergonomics:

In micro gravity conditions human dimensions must be considered in order to provide an environment that is both comfortable and functional. The center must accommodate size ranges from the smallest (5% female) to the largest (95% male) crew members.

Micro gravity effects (NASA STD-3000, 1989):

- * Height increases of up to 3% as a result of spinal lengthening
- * Relaxed body posture due to reduced gravitational loads.
- * Dimensional changes in the circumference of the chest, waist and limbs due to fluid shifts.
- * Locomotion changes due to the reduced traction associated with walking and running, cause humans to tend to bound or lope
- * Mass reductions caused by the loss of body fluids and muscular atrophy.

Design Issues:

- * Unisex/size elements that accommodate the full range of possible crew members
 - * Flexibility and adjustability of furnishings and equipment like chairs, keyboards, screen angles, etc.
 - * Ceiling heights that accommodate the largest crew- members, and are psychologically proportioned as to reduce stress caused by closed cell living.
 - * Switches and controls that accommodate the smallest crew members reach capabilities.
- (For more detailed Information see NASA-STD-3000 Sec. 3.0)

Design Recommendations:

The Command Center is a public place that must be accessible and adaptable in order to accommodate the 5% female and the 95% male population. While many functional specifications give maximum and minimum tolerances, aspects such as psychological implications and effects must also be considered.

2. Coding:

Coding is an important issue for all operations, systems and equipment. As a result of its role in systems and activities monitoring, the Command Center is tremendously dependant upon coding. The locations and status of activity or emergency conditions demands that a clear, universal system of coding be used to properly execute base functions.

Design Issues:

- * Coding of base systems, status and location
- * Coding of backup systems, status and location
- * EVA location coding system for field communications, and instructions.
- * Maintenance location coding allows for easier preventive repair and replacement of instrumentation.
- * Emergency location coding allows for the quick and efficient execution of rescue and emergency repair operations.
- * Understandable Coding systems that are easy to teach and use.
- * The Coding Systems should be consistent for all personnel throughout the entire base, both interior and exterior locations.
- * Coding of directional information such as forward/aft, port/starboard, and up/down by the use of color. (See NASA-STD-3000 Sec. 8 for color specs.)

Design Recommendations:

Coding is necessary for the monitoring and control of base functions and activities. Control and display panels, systems, components and equipment all require coding in order to function effectively.

3. Color/Decor:

Color and decor have definite impact on the aesthetic quality of the Command Center environment. The psychological, functional, and habitable qualities are dependant upon the selection of aspects like color, texture, materials and lighting.

Design Issues:

- * Simple, uncomplicated visual patterns reduce over stimulation.
- * Large areas should be colored with diluted colors that won't cause visual over saturation.
- * The use of dark or saturated colors should be limited to small areas.
- * Variety of decor and colors that deters boredom and environmental monotony.
- * Maintenance of decor should be simple or unnecessary, and must be easily repaired or replaced.
- * Colors can be modified with different lighting levels and sources. (See NASA-STD-3000 Sec. 8)
- * Texture adds a sense of dimension to interior decor, and should be applied in simple, regular patterns.
- * Rough textures diffusely scatter light and are useful in reducing glare.

Design Recommendations:

Taking into consideration the selection of color, texture, material finishes and decorative

accessories, the Command Center interior should be designed to enhance and support the comfort, performance and health of the crew.

4. Productivity:

The functional aspects of the Command Center, the proximity of controls and displays, and their orientation combine to support the productivity of crew personal. Space efficiency is a primary concern with regard to functional aspects such as control spacing and equipment requirements.

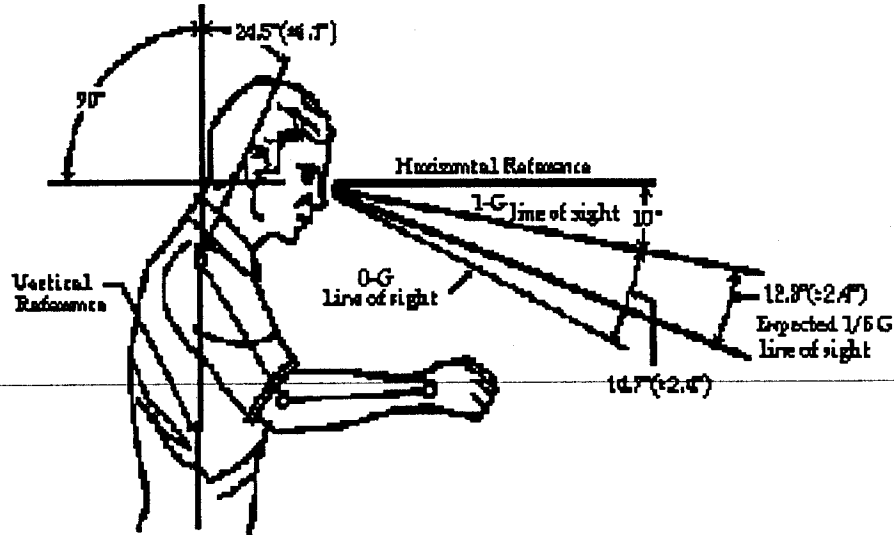

Design Issues:

- * Control spacing, switches, knobs and levers should meet functional requirement minimums
- * Emergency system controls require easy operation by gloved fingers in the event of a depressurization accident. (See NASA 14.4.3)
- * Controls and displays shall be accessible to all users.
- * Controls and displays should be grouped in proximity
- * Displays should be positioned so as to be perpendicular to the viewer or at an angle of not more than 30 degrees.
- * Controls for visual displays should be positioned as to allow for precision adjustments while concurrently monitoring the screen or other controls.
- * Sequential grouping should be employed where a pattern of control actions exist.
- * logical grouping of controls that are not involved in functional or sequential groups should be arranged according to their importance and the frequency of their usage.
- * Emergency controls and displays should be placed where they are immediately accessible.
- * Control movements should be consistent throughout the center to avoid mistakes.
- * Remote control of equipment and vehicles must be arranged to provide consistent, smooth operations.
- * Controls and displays in the Command Center shall have a consistent orientation in relation to each other as well as to equipment in other areas.

Design Recommendations:

The controls, visual displays and equipment must be arranged in a specific, simple manner in order to support the productivity of the crew. The design must incorporate the consistent layout and configurations that are used throughout the entire base. (For specific data, consult NASA-STD-3000 Sec. 9).

5. Maintenance

The maintenance of the Command Center is of extreme importance to its continuous function. Visual and physical access, redundancy, modularity and simplicity, play important roles in functional aspects of the design. Maintenance must be easy, and not interfere with on going base operations.

Design Issues:

- * Maintenance should be conducted in a manner that is both preventive and non-interferent.
- * Redundancy of systems operations is necessary to facilitate the continuous operation of base systems.
- * Reduction of crew training and skill level requirements, and time spent on maintenance.
- * Fault detection and isolation should be automated.
- * The center shall be designed as to accommodate systems growth, replacement and updating.
- * Operations systems should be designed to be as independent as possible to facilitate easy maintenance.
- * Equipment must be designed to allow maintenance that requires a minimum number of tools.
- * All connectors, plugs, and fasteners should be designed to accommodate easy hardware installation and mounting techniques.
- * Access to repair or replace components should not require the removal of more than one access panel.
- * Life support and emergency systems must be accessible, removeable and repairable by personnel in an EVA suit.
- * Large panels that access a number of different installations are preferable to a number of individual panels.
- * Equipment, racks and bulkheads should be removable to provide access to the entire vessel skin.
- * Equipment, racks and bulkheads should be of consistent modular design to facilitate replacement modification and expansion.

Design Recommendations:

Maintenance of the control center must be simple and efficient for all crew members. Accessibility to components should be of sufficient size as to allow quick repair or replacement. In addition, all systems should have backup capabilities to allow for independent and uninterrupted operation.

6. Atmospheric /Thermal:

Atmospheric composition quality and thermal conditions must be responsive to human health and physiological aspects. Individuals must be able to control their environment to suit the function involved.

Design Issues (NASA STD-3000, 1989):

- * The atmospheric content must be maintained at a level that protects crew from hypoxia and hypoxia.
- * The cabin pressure must be of sufficient minimum force to prevent the loss of body fluids.
- * The atmosphere composition should have minimal flame/ explosion potential.
- * Thermal monitoring and control should be fully automatic, and yet allow for manual personal adjustments.
- * Atmospheric parameters such as humidity and ventilations rates should be controlled automatically and shall be uniform with base requirements.
- * Surfaces that come into contact with bare skin should have a minimum temperature of 4 degrees C, and a maximum of 40 degrees C. (NASA-STD-3000, 1989)
- * Thermal conditions can also be influenced by other design issues such as color, lighting, and texture.

Design Recommendations:

The atmospheric design of the center must incorporate continuous automatic monitoring systems with manually adjustable controls. In order for humans to survive and function in an enclosed environment, atmospheric composition, pressure and temperature must be maintained to needed levels.

Parameter	Units	Operational	28-day emergency
Temperature (1)	° F	65-80	60-85
Dew point (2)	° F	40-60	35-70
Ventilation	f/min	15-40	10-200
SI units			
Temperature (1)	° K	292-300	288-303
Dew point (2)	° K	278-289	274-294
Ventilation	m/sec	.08-.20	.05-1.0
Temperature (1)	° C	18-27	18-30
Dew Point (2)	° C	5-18	1-21

Reference: 5, Figure 83, Page 302
324, Table 2-8

Notes:

- (1) In the operational mode temperature will be selectable $\pm 1.1^{\circ}\text{C}$ ($\pm 2^{\circ}\text{F}$) throughout the range
(2) Relative humidity shall be within the range of 25-75 percent

Figure 5.8.3.1-1. Atmosphere Thermal Comfort Requirements

(NASA STD-3000, 1989)

7. Lighting:

Command Center lighting systems should be designed for optimal viewing conditions for all activities. Critical usual tasks that require discrimination of color codes, seeing fine detail and monitoring screens are important aspects to consider.

Design Issues:

- * Due to the color coding involved in command Center functions, white light sources should be used because of their natural qualities.
- * Lighting intensity should be sufficient enough as to allow desired visual efficiency without creating glare.
- * Lighting systems should be provided for crew members performing visual tasks that require intensities greater than those of the general illumination.
- * Instrument displays and CRT's may require lower levels of general illumination.
- * Avoid glossy, highly-polished surfaces that can cause adverse glare problems in relation to monitors and display legibility.
- * Glare can be reduced at the source by the use of filters or polarizing lenses and shields.
(Refer to NASA-STD-3000 Sec.8 for illumination standards).

Design Recommendations:

The illumination of the Command Center should provide for a flexible range of operations. Supplemental light sources should be designed to be flexible, and adjustable in order to accommodate a variety of tasks. Reflection and glare should be minimized by, the placement of light sources, the texture of work surfaces and the placement of visual displays.

8. Acoustics

Acoustical design considerations involve the production, transmission and effects of sound in a closed environment. Aspects such as auditory sensation, distraction and noise exposure limits, for working areas have a definite effect upon operations performance.

Design Issues:

- * The center shall be insulated against noise from other areas.
- * The center shall be insulated from the sound of ventilation and mechanical equipment noise.
- * The noise level in the environment must not interfere with communications or social interaction.
- * The design must consider the passage of sound through materials via vibration, and effectively buffer them.
- * Selection of surface treatments for the absorption of sound is necessary to insure proper reverberation and reflection of sound. (Consult NASA-STD-3000 Sec. 5 for sound intensity spec's.).

Design Recommendations:

The acoustical concerns of the command Center make necessary the use of sound insulating, elimination, and control. Operations require communication at normal voice levels for optimum efficiency, and the reduction of interference and distractions.

B. Intra-Base Communications: Teleconferencing, and Meeting Facilities

The following are design considerations and requirements for meeting facilities. The wardroom is a possible use for a teleconferencing area.

1. Orientation and Capacity of Areas

These areas should be flexible in locations of furnishings, seating, and restraints. The arrangements of these spaces should be versatile.

The following are possible arrangements:

- a. Entire crew interaction
- b. Multiple group involvement
- c. Small discussion groups
- d. Individual groups
- e. Auditorium size interaction

These must accommodate the appropriate number of persons comfortable and safely. All entry, passage and volume requirements must also comply.

2. Location of Areas Within Module(s)

Facility should be centrally located to minimize transit times.

For long durations of meetings a waste management facility should be near.

Availability of refreshments is desirable near the meeting facility.

It is advisable to locate meeting facility away from areas sensitive to noise.

The following are some facility types:

- a. Multi group facility
- b. Auditorium facility
- c. Individual facility
- d. Internal proximity of the preceding areas to others.
 - (1) Group areas to wardroom area; etc.
 - (2) Individual facilities to personal areas.

3. Environmental Considerations

Noise level must be sufficiently low to conduct meetings. Temperature and ventilation must be able to accommodate several different groups.

4. Accommodations Within Each Facility

Round or square tables (refer to NASA-STD 3000 fig. 10.6.2-1)

The facility should provide equipment storage necessary for the conduct of meetings. The following are some requirements and considerations:

- a. screen or central display area
- b. two way communication facility for participation of persons outside of module.
- c. projection system
- d. audio-video equipment for recordings and playbacks.

Seating arrangements should consider both bench and individual types. For screen auditorium arrangements refer to NASA-STD 3000 fig. 10.6.2-2.

5. Anthropometrics

The meeting facility furnishings should be easily repositioned to meet the appropriate conditions.

6. Coding

All materials should have the appropriate identification markers. All areas leading to and from meeting facilities should be free of any debris. All material should be color coded. The decor of each meeting facility should be color coded also, this will help to distinguish between other areas.

7. Acoustics and Sound Transmission

The acoustic environment of the meeting facilities shall meet NASA-STD 3000 paragraph 5.4.3 2.2.1

8. Power Sources

Each piece of equipment shall have auxiliary power packs for emergency use. Initial power shall be supplied by the module itself.

9. Redundancy

Backup systems should be provided for the more important equipment.

10. Design Issues

The following should be considered for the entire facility when designing:

- a. Proximity
- b. Lighting
- c. Atmosphere control
- d. Color and decor
- e. Social interaction
- f. Ability to personalize
- g. Materials
- h. Productivity
- i. Privacy

C. Logistics Modules/Storage Systems

1. Anthropometrics

In order to conserve on EVA time consideration must be given to design aspects of logistic module interfacing equipment with regard to mobility and transport/transfer systems, module integration, and docking systems. The logistics modules must be transferred from landing vehicles to transport vehicles, carried over lunar terrain and docked to the base module interface. These systems must easily integrate with the typical module configurations: the pressurized logistic supply module, fluid tankage shipping module and the unpressurized container pallet module. Design criteria must correlate with docking and interface systems established for the space station systems.

2. Atmosphere Control

An unpressurized warehouse surrounding the base logistic module interface (docking systems) should provide protection from solar activity, micro-meteors, and ground blast from the landing site. This area should be large enough to accommodate two to four docked supply and tankage modules as well as storage for pallet modules and queuing areas for incoming and outgoing modules. This area could also store for long term purposes modules used as collection containers for trash and wastes until final disposition.

The module interface should lead into the pressurized warehouse area which will allow shirt sleeve access to the supply and tankage modules.

These systems will be developed over a phasing in period as the mission frequency and stay increases.

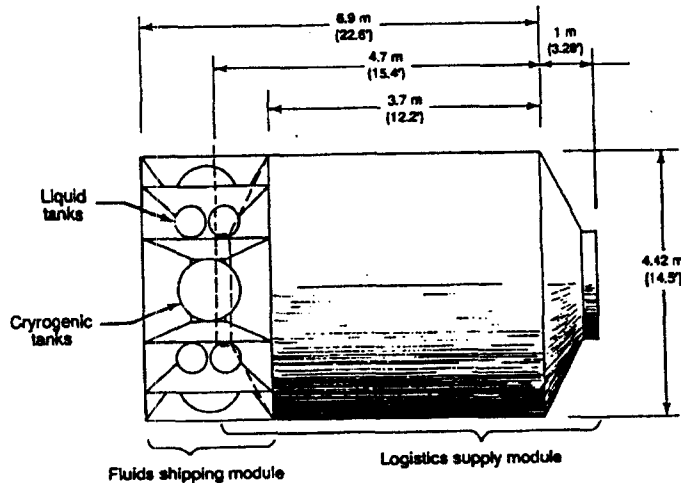

3. Ergonomics

Anticipation of multinational and multigender personnel will affect design criteria for the systems considered in the transfer, transport, docking and access of the logistics modules.

4. Coding

Multinational consideration must be given in the design of instructional or identifying codes for the above systems and alternative uses of modules. Harsh lighting and dust conditions need to be considered in the unpressurized warehouse.

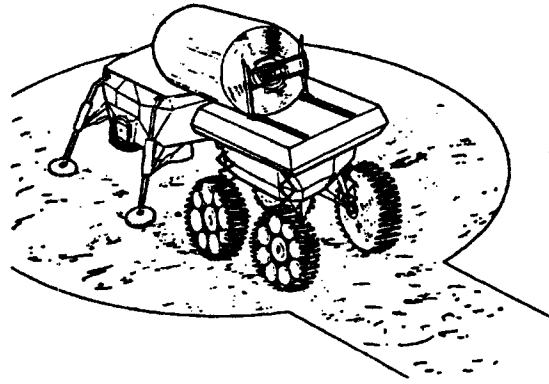

5. Proximity

Location of the logistic module interface must be convenient to the landing site to minimize EVA time during retrieval or disposition activities. The logistic module interface must also be efficiently located in the lunar complex to provide easy distribution of supplies, ease of access to modules containing experiments or work activities, safe transfer of returning experiments, and possible trash and waste collection in empty modules.

This suggests two possible locations for the interface: first stage or 'front door' of the base complex, and centrally located within the base complex.

D. Safhavens/Emergency Systems Requirements

1. Fire Protection

a. Fire Extinguisher Facilities

The type of fire extinguisher should cover fire caused by chemicals and electric machinery.

b. Location

Fire extinguishers should be located every 4 meters.

c. Number of Fire Extinguishers

There should be 4 fire extinguishers for each floor.

d. Temporary Safehaven in the event of fire

Temporary safe haven can be created by a thermal insulating blanket. The surface material of the blanket should be nonflammable. The internal material should be glass wool for insulation.

e. Escape Method from Fire

If the crew cannot escape to the other module, they will don a space suit and open a valve which emits the air inside to extinguish fire. Then they will open the hatch and go outside.

2. Meteor Protection

a. Outer Surface Protection

As a design requirement for equipment and shapes of equipment, all surfaces will be designed to deflect falling meteors.

b. Forecast of Meteors

If a meteor includes metallic ingredients, radar can detect it.

c. Protection for Crews

If the crew recognizes that the surface of the habitation module has been hit by meteors, they should don a space suit and stay in a place where the wall thickness is maximum.

3. Supplemental Air Supply

a. Method of storage

Air tanks should be protected under regolith at the depth 1 meter.

b. Capacity of storage

A total of 40.13 kg of air should be stored for 7 crewmembers per week.

4. Supplemental Food and Water Supply

a. Methods of storage

Food and water should be adequately protected from contamination and safeguarded from radiation.

b. Capacity of Storage

Approximately 63 kg of food should be stored in the safehaven to provide two weeks of supplies for a crew of 7.

c. Method of Supply

Approximately 214 gm packages of food can be distributed to the crew, three times daily (640.8 gm food per crewmember per day.)

5. Spare Equipment

a. Method of storage

The spare equipment should be packed before it will be buried underground, at a depth of 2 meters. The lunar soil above the equipment will protect against meteors.

E. EVA Chamber

The design of the EVA chamber covers the architectural and engineering requirements. The EVA chamber includes the main storage area which is the interface space between the main storage area, the habitation modules, and the EVA exit space. The main concern for the EVA chamber is the containment and removal of lunar regolith which accompanies the crew members into the lunar base from the lunar surface. The EVA exit/ entrance space is designed to be an airlock and dust lock space. For the initial base layout the exit space and the dust off space will be the same area. As the base expands the two areas will be separate spaces.

1. Anthropometrics

a. Size

The size of spaces, size of hatches and system control locations/positions will be designed to accommodate the upper 95 percentile male and upper 5 percentile female body dimensions. The requirements for size of the exit chamber will allow 2 crewmen to comfortably move about in their EVA suits with equipment and tools. The size is also designed by the requirement to minimize the exit/dust off space. This minimizes the the air removal requirement. This minimizes the time required to evacuate the air from the space, the air evacuation equipment running time, evacuated air storage requirements and the corresponding air make up requirement upon re-pressurizing the space. The expected air loss is 5% of the initial volume due to evacuation equipment limitations (Essex Corporation, 1988).

b. Suit Don/Doff

The main EVA space will be sized to accommodate EVA suit storage, suit donning and doffing. The size of the space will accommodate suit cleaning, suit maintenance and suit resupply needs. The suit expected to be used is the "Hard Suit".

c. Hatch Sizes

The hatches will be sized to allow ease of exit and entry into the EVA spaces by crew members in the EVA suits. Because of the expected clumsiness and balance control by crewmen while in the EVA suits, exits and entrances are sized to allow one crewman at a time to pass through easily. Special needs will be encountered and designed for when the emergency scenario concerning passing an injured crewman through the passages.

2. Coding

All hatches and controls for EVA use will be marked according to NASA standards. The marking of hatches and controls will remove confusion of system operation or control.

3. Color/Decor

The color and decor requirements are minimal. System fittings will be covered or hidden to prevent damage to the systems from exposure to lunar regolith. The color of the EVA spaces will be white. This will assist crewmen in locating areas contaminated by abrasive lunar regolith. The sterile image for these spaces should be maintained to stress the need for maintaining containment of regolith. Since the EVA system will be designed for team use, the psychological effects of the stark white color will be minimized by the continual social interaction.

4. Materials

The materials considered here are the surface materials. The structural materials, design and ability to provide support for pressure changes are assumed to exist.

a. Durability

The surface materials will be durable. The material should survive the abrasive effects of the crew traffic and the lunar regolith contact.

b. Cleaning

The vertical surface material should be smooth. The surfaces where crew member traffic is expected must be rough to provide adequate footing. All other surfaces should be smooth. The smooth surface will facilitate clean up of the lunar regolith contamination. Clean up will be conducted with wipes or with a vacuum cleaning system.

c. Structural Strength

The structural strength requirements for the materials of the EVA chamber are; the materials must be designed for the life of the lunar base, the materials must withstand the pressure changes from 0 to 10 psi in the exit compartment and the materials must maintain structural strength after corrosion and wear effects are considered.

5. Thermal/Light Requirements

The lighting for the EVA system spaces will provide adequate safe levels of lighting for all aspects of the EVA process. The lighting system, when available, will be an as needed system to reduce the power requirement and the thermal effects from the lighting.

a. Exit Chamber

The exit chamber lighting will be designed to provide for crewmen to have adequate adjustment to lighting conditions on the lunar surface at the time of EVA. EVA operations during lunar day light will require lighting in the EVA chamber to be normal lighting.

During lunar night EVA operations, the EVA exit space lighting will be a minimized red lighting during the de-pressurizing period. This will provide adequate night vision preparation for the EVA exit. During entry from the lunar night, the lighting will initially be red. As the re-pressurizing process continues, the lighting readjusts to normal lighting levels at small incremental changes in light intensity and color.

b. Main Chamber

The main chamber lighting will be at normal lighting levels. The lighting will also be an as needed system with manual switches to turn lights on and off. Controls for the main chamber lighting will be present in the main chamber and also the EVA or dust off space. The secondary control allows the returning crewmen to control the main chamber lighting if no crewman is available in the main chamber.

c. Dust-off Room

The dust off room lighting requirement may be the same as the exit space requirements depending on the actual design and layout of the EVA system. With the dust off room as a separate space located between the main chamber and the exit space, the lighting requirements would be normal lighting with high lighting level control to assist in locating regolith contamination. Control for the lighting will be located in the exit space, the dust off space and the main chamber.

6. Health/Safety

a. Emergency Pressurizing

In the event of an EVA accident where a crewman has been exposed to a low pressure atmosphere but not a complete vacuum, special needs for pressurizing are required. The requirements needed concerning the pressurization rates will be provided for by the EVA pressurizing capabilities.

b. Removal of Injured Crewmen

The removal of an injured crewman presents a variety of requirements. The discussion of injury procedures will be limited to injuries where the crewman is ambulatory and those where the crewman is either unconscious or cannot walk.

When the crewman is ambulatory, no real alteration in design criteria is needed. For those injuries where the crewman cannot walk, sizing of the entrance space must provide adequate space for the crewman to be placed into the space longitudinally. The space will be designed for facilitating one crewman bringing another crewman into the space by a litter. Removal of the injured crewman through the dust off space and into the main chamber will spread regolith into spaces. This contamination is based on attending to the injuries first and cleanup of the contamination secondly. A more extensive cleanup of spaces will be required immediately after removal of the injured crewman.

c. Remote Operation

Remote operation of the EVA system is based on pressurizing the EVA exit chamber in the event that a crew member enters the space from the lunar surface and controls in the exit space do not function. Controls for operation of pressure control will be provided in the main chamber and the command center. This provides reliability and safety for the system with back up controls for redundancy.

d. Remote Monitoring

Remote monitoring of the EVA chamber will include visual and audio monitoring of each space in the EVA system. Other remote monitoring will be for space pressure, temperature, humidity and airborne particulate levels. Monitoring stations will be located in the main EVA chamber and the command center.

7. Social Interaction

a. Communications

During the de-pressurize time period, communication links between the EVA personnel and the EVA monitoring personnel will be established. This communication link, added to the visual monitoring, will allow EVA crew members to quickly inform EVA monitoring personnel of problems or difficulties during de-pressurizing. The de-pressurizing can be stopped and re-pressurizing can take place to allow crewmen to repair the problem in a normal atmosphere.

b. Activities during pressurizing/de-pressurizing

The activities of EVA crew members during de-pressurizing or re-pressurizing will be for last minute mission preparation and mission reporting. The de-pressurize or pressurize time period is system dependant. If a long period of time exists, the communications link will aid in alleviating anxiety and allow for productive use of crucial time.

8. Wayfinding

The lunar base is designed for operation and use by different base teams. As a necessity to remove confusion for specific operation of systems and for quick location of components, a method of wayfinding is needed. By proper location, markers for the EVA system, possible hazardous situations for new, semi-oriented crew members can be eliminated.

a. Lighted pathways to EVA

Lighting the external lunar base pathways to the EVA exit/entrance space will be required. The lighting of the pathway will allow recognition from 100 meters. Proper design of the lighted pathways will be conducted. This design will take into consideration the visual aberrations caused by the lunar lighting and the absence of a lunar atmosphere.

b. Color coding controls

Color coded controls for each specific EVA system will be provided to assist crew members in the system operations. System piping diagrams and wiring diagrams will be provided at control stations to assist in system operation.

c. Marking of EVA hatches

EVA hatches will be marked according to NASA standards to ensure that hatches are not mistakenly operated causing severe damage or harm to systems or crew members.

9. Productivity: Minimize EVA Chamber Size

a. Air make up

The size of the EVA exit space must be limited based on previous design considerations to ensure that make up rates of air lost to the lunar atmosphere are minimized.

b. Time in EVA

The size of the EVA exit chamber being limited due to the make up air requirement also serves to reduce the crew members time in the EVA space. The smaller the size of the EVA space, the time required to evacuate the air and the amount of space required for air storage is minimized. Limiting the time in the EVA exit space reduces the non-external working time a crewman must spend on their suit life support system. This increases the work time available outside the lunar base.

c. Don/doff time

By designing the main chambers DON/DOFF area, a more efficient and productive procedure for suiting up or down can occur. Limits on this consideration is based on the actual suit design and its donning requirements.

d. Clean-up time

The design of the dust lock area will be for quick , complete removal and storage of the lunar regolith. The use of dust protecting outer garments during EVA operations will aid in removal of regolith from the EVA pressure suit.

The requirements for washing the pressure suit and sterilizing the inside of the suit is present. The suit cleaning systems and procedures will allow for a quick and effective cleaning of the suits.

Actual clean up of the dust off space will have increased productivity with the use of a vacuum clean up system and possibly a particle de-ionizer. Automated air cleaning systems such as electrostatic precipitators will also assist in increasing the productivity by having more than one clean up activity occurring at one time.

10. Atmospheric Control

The atmospheric control of all spaces involved with the EVA system will be of particular importance because of the variation in actual pressures, temperatures, and amount of contamination each space sees during its normal operation.

a. Pressurize/de-pressurize

The process of pressurizing and de-pressurizing the EVA exit compartment requires adequate pressure control. Pressure levels will be monitored to ensure that safe operating levels are maintained. The EVA system will have backup systems to ensure crew safety.

b. Suit revitalizing

The need for fully operational EVA suits dictates the need for a reliable suit resupply system. Suit life support system testing and the actual resupply of oxygen and suit system power supplies will be provided.

c. Air storage/make-up

Oxygen and nitrogen gas storage systems with associated controls are provided to ensure operation of all phases of the EVA system. EVA evacuated air storage tanks will be provided to minimize the needed air make up to the EVA exit compartment. When make up air is required, oxygen and nitrogen storage tanks and the associated control systems will be provided.

11. Ergonomics

Operation of system switches and control valves by crew members in EVA suits would be limited by improper design of the control system components.

a. Valve handles

The valve handles in the EVA exit space and the dust off space will be designed to accommodate the larger size and restricted movement needed for control by an EVA suited crew member. Valve handles will be designed for quick acting valves.

b. Hatches

Hatches will be designed with simple positive closing hatches. The hatch control handles will be operable by suited crew members. The handles will be large and the required motion for operation will correspond to the capabilities of the EVA personnel.

c. Controls

Push buttons, switches and other control components will be designed for operation by suited crew members. The controls will be designed for operation by unsuited crew

F. Power Systems

The aspects covered in the design of the power supply include architectural and engineering concerns involved with the deployment and operations of the lunar base power system. The main concerns with the power system are the reliability of power and the safety of the power system.

Three power system types are considered for use in the lunar base design. These systems are; solar power plant, fuel cells, and nuclear power plants.

Based on the information available and the design criteria, the power system selected is the nuclear power plant system.

1. Power Requirements

a. Base power needs

The power required by the base during its stages of development has been defined initially as requiring 25 Kw of electric power. As the base is completed the power requirements reach 300-500 Kw of electric power (Mendell, 1985)

The initial power is supplied from an Radio-isotope Thermoelectric Generator (RTG) nuclear system. The power system is then designed with SP100 Nuclear reactors.

Remote operations

The power systems for remote operations such as a remote observatory, mining/manufacturing facilities and remote construction sites will be provided by RTGs. As the remote operations become fully operational, the power system development will follow that of the lunar base.

b. Day/night needs

The base operation scenario is for a continuously operable power system. The expected power demand is constant.

Based on building phases

The power demand expected for the lunar base during its construction phases are defined in the following table.

Table 3. Stages of Lunar Development and Power Requirements

Stage	Activity	Power Levels	Probable Nuclear Power Supply
1	Automated Surface Exploration/ Site Preparation	kWe	Radioisotope generators
2	Initial Lunar Base (6-12 persons)	~100 kWe	Nuclear Reactor (SP-100)
3	Early Lunar Settlements (100-1000 persons)	~1 MWe	Expanded SP-100 (Advanced Design)
4	Mature Lunar Settlement (~10,000 persons)	~100 MWe	Nuclear Reactor (Advanced Design)
5	Autonomous Lunar Civilization (Self- sufficient Lunar Economy: >100,000 persons)	hundreds of MWe	Nuclear Reactors (Advanced Design, Complete Lunar Nuclear Fuel Cycle)

(Mendell, 1985)

After completion of the lunar base, power demands will increase as the activities and operations are fully developed. To meet these higher power demands more nuclear power plants will be added , giving more flexibility and reliability to the lunar community.

2. Expansion of Use

The power system must have the potential to expand with the growth of the lunar base. This expansion starts from the initial construction into the fully operational phase. The system may either be sized initially to meet the expected full operation requirements or may be designed such that as the power needs increase, the system will then be expanded.

3. Efficiency Control

The efficiency of the power plant is dependant upon proper maintenance of the plant. Many of the proposed systems use heat engines. The temperature of the deep space radiator (heat sink) has a great effect on the heat engine efficiency.

4. Back up Systems

The power plant will require back up systems for control, power conversion energy storage or back up power. The selected power system must have a minimal amount of required back up systems. This increases the reliability and efficiency and decreases the plant assembly time. The minimal back up systems also limits the required maintenance of the power plant.

5. Constructibility

The power plant should require a minimum construction effort. Because the power system is needed as soon as base construction begins, it must be constructed quickly and easily.

6. Reliability and Maintenance

The power system must have a high degree of reliability. By minimizing the back-up and auxiliary equipment required for the power system, the reliability is increased. The power system will be designed to allow for a minimum of maintenance required. The system will be designed to facilitate the required maintenance.

7. Safety

The power plant must be designed to limit the base crews direct exposure to high temperatures, high voltages, radiation and physical hazards cause by machinery. The power system will be designed to provide for crew safety during periods of maintenance and repair. Adequate design for emergency systems dealing with the power system will be present.

8. Selection of Power Unit

From the power systems available, the system selected is the nuclear power plant system. The nuclear power plant has increased reliability , has the ability for expansion, has the ability to be delivered to the lunar surface assembled, can be located in existing landscape and can be made safe for human activities.

The previous table shows the development phases of the lunar base and the power requirements. This is consistent with the available present technology. The past performance of nuclear power systems in the space program meets the design criteria and power needs for a lunar base application.

The technology for the application of the Stirling cycle heat engine is not available at present . The efficiency available from the Stirling engine dictates that the technology for its use be developed.

a. Solar Cells

This system requires a large field array, a precise efficiency monitoring system with auxiliary systems to be constructed from materials brought from earth. Solar tracking is easy in one axis.

Expandable:

The solar power plant meets the design criteria for expendability by placing into service more photo cells as the power needs increase and as the photo cells degrade with age or damage. Expanding the system increases the amount of control and monitoring equipment required by the system.

Efficiency control:

The efficiency of the solar power plant is dependant upon maintaining the proper angle of the cells to the incident sunlight. With a lunar equator base location the angle of the sun varies. The power needed to drive the tracking system decreases the overall plant efficiency.

The type of photo cell selected is a gallium arsenide cell. This type of photo cell has the lowest loss due to radiation and thermal effects. In an array, the photo cell may reach an optimum efficiency of 20.5%.

The efficiency of the back up fuel cell power plant and the associated heat engine are limited by the temperature of the heat sink for the engine.

30 kW REGENERATIVE FUEL CELL SYSTEM^(a)

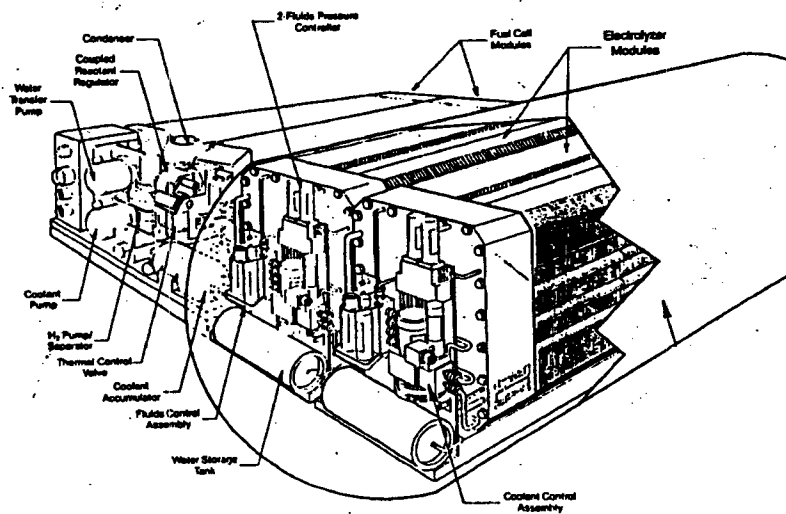

Needed back-up systems

The solar power plant requires a back up system during the lunar night and during periods where the photo cells cannot provide the base power requirements. The back up system best suited for this is a fuel cell which drives a Stirling cycle heat engine. The heat engine drives a generator to produce electric power.

A battery storage system will be required to store electrical power to be used to allow completion of required maintenance or repair during the lunar night.

Constructibility:

The construction of the solar array field is accomplished by constructing a platform to mount and position the photo cells. The solar array field may also be constructed by attaching the photo cells to a flexible matting that can be rolled onto the lunar surface. Prior to the placing of photo cells the lunar surface will require some initial conditioning.

The construction required for the backup systems include excavation for the storage of the fuel cell storage tanks, the storage for the battery system and the fuel cell power plant.

The requirement for a back up power system and its associated power conversion and tracking equipment allows for equipment failure to severely effect the power generating capabilities of the plant.

The battery storage and thermal storage systems increase the reliability of the system. The storage systems provide a power source that will be used during maintenance and repair of the solar power system.

Safety:

The solar power system is inherently safe. The energy storage systems must be designed to protect the crew members from high voltage and high temperatures during the power systems operation. The fuel cell fuel requires storage in buried gas storage tanks. Storing the fuels below the lunar regolith protects against micrometeorite and thermal damage. The fuel cell fuel is very explosive, for that reason the fuel cell power system must be located safely away from the lunar base.

b. Fuel Cells**Expandable:**

Fuel cell power plants are expandable by adding more fuel cells to the power system. The fuel cells must be sized for the expected power requirements. The expansion of the system is made in very large power increments. Due to the delivery of the fuel cell plants and fuels from earth, the launch requirement for expansion is a prime factor for sizing the fuel cells to meet the base power requirements.

Efficiency control:

The efficiency of the fuel cell power plant is controlled by the temperatures of the heat engine heat sink. The efficiency is controlled by the deep space radiator.

Needed back-up systems:

The back up systems required for the fuel cell power plant are a battery storage system and a thermal energy storage system. The battery storage system is required for periods of maintenance or repair. The thermal energy storage system is required for continued operation of the heat engine during the same periods of maintenance and repair of the fuel cells.

Due to launch considerations for the delivery of the thermal storage system medium from earth, the thermal energy storage system is impractical.

Constructibility:

The construction considerations for the fuel cell system are discussed in the solar power plant construction section.

Reliability and maintenance:

The reliability of the system is increased with the battery storage system. The storage

lunar surface. The lunar soil is a poor shielding material. There may be shielding material brought from earth to more effectively shield the radiation and allow for the reactor to be located closer to the lunar base, reducing the losses due to the transmission lines

Reliability and maintenance
The RTG technology is past proven in earlier space programs. The initial RTG power plant involves no moving parts and therefore has a high reliability.

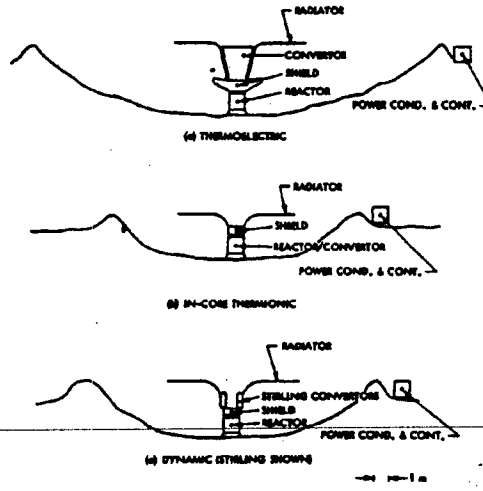

With the expanded power system there will be many heat engines to provide greater reliability. The heat engines have moving parts which will have mechanical wear and also a lower reliability due to increased maintenance.

Safety:

The radiation shielding is the main area of safety to be considered with the nuclear power plant. Using the lunar soil as shielding and possibly using some shielding material from earth, the radiation levels will be controlled. Placing the reactor a safe distance from the lunar base will also protect the crew from radiation and from potential accident hazards. The reactor area will be properly marked to indicate it as an unsafe area.

9. Power Plant Location

The location of the power plant in proximity to the lunar base will be based on the site location of the base. The availability of natural craters will dictate the need for excavation and location of the reactor plant. The distance the plant is located from the lunar base will also be based on the availability of shielding material and the expected radiation levels.

10. Remote Control and Monitoring

The radiation levels that the crew receives will be monitored. The continuous radiation monitoring will limit the risk and degree of exposure to health hazards the crew receives from the reactor plant.

11. Auxiliary system support

- a. Equipment location
- b. Maintenance
- c. Other aspects
 - Noise, heat, dangerous voltages, waste products production and disposal

Energy Conversion/Storage System

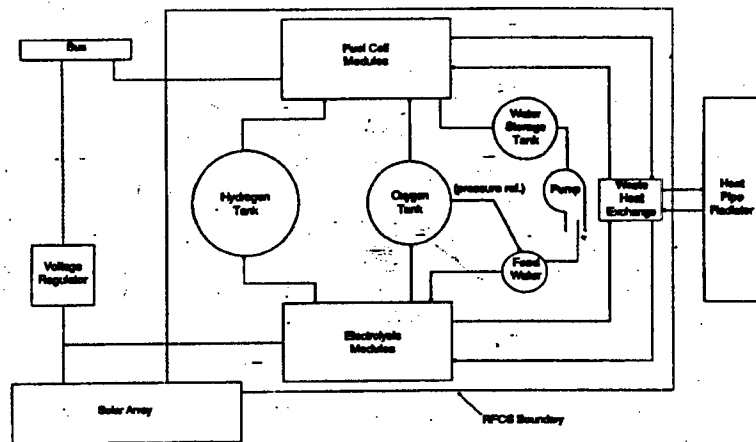

Figure 3

G. ECLSS/HVAC Systems

This section deals with the architectural aspects and design requirements of the Environmental Control Life Support System (ECLSS). The ECLSS will provide an open loop system which will require make up quantities of potable water and atmospheric control gases to be delivered from earth.

The design of the ECLSS is based on the need for an entirely closed loop design. The design of the ECLSS will allow direct incorporation into the closed loop life support system.

The life support system will be designed to recycle much of the water and atmosphere. This minimizes the required quantities to be delivered from the earth. The life support system will provide an internal base pressure of 10 psi. The ECLSS will provide a regulated temperature and humidity level for a shirt sleeve working environment.

1. Coding

a. System identification

Each system required for the control of the life support system will be uniquely marked following NASA standards. This marking will eliminate confusion of the controls of the various systems.

b. Special markings

All handles, valves, motors, pumps and storage tanks will be marked to ensure that special precautions required by each system are adhered to. The special markings will provide warnings and directions to the crew members to prevent harm to the systems, the lunar base or to the personnel. The marking of system components will make maintenance and repair easier and aid in assuring the maintenance is completed properly.

2. Color/Decor

The color of the systems that are exposed to crew observation will blend in with the decor of the particular spaces. Only the marking of special system control components will stand out in regards to the spaces decor.

3. Materials

a. Strength

The materials selected for the system components will meet requirements of strength and durability. The standards for the material strength are for launch acceleration forces considerations for assembled systems and for reliability of operation for the initial base expected life time.

b. Noise/vibrations

In the systems where vibrations are present during operation, the material selected will either dampen the vibrations or other material which will reduce the vibrations will be added to the system components.

c. Odor and taste

In the water and ventilation system, material will be selected which do not contribute any odor to the space or any taste to the potable water. This will be important in the humidity reclamation system connected to the ventilation system. The water treatment system will require chemical treatment for bacteria control, the chemicals used will be selected to limit the taste imparted to the potable water.

4. Thermal/Light Requirements

a. Power load

Adequate temperature control will be provided in the shower, personal hygiene, food preparation area and the laundry facility such that the hot water used will not cause personnel injury.

b. Heat generated

In areas where the required lighting is high, excess heat will be generated from the lighting sources. This excess heat will be removed to prevent an unsafe temperature condition from occurring.

5. Health/Safety

a. Air quality

The ECLSS will be designed so that the air in the individual modules is free from noxious fumes, dangerous levels of deadly gases. Irritating and damaging particulate matter will be filtered from the ventilation system.

Carbon dioxide level

The carbon dioxide level will be continuously monitored. The acceptable level of carbon dioxide is based on NASA standard 3000 sec. 5.1.2.2.1.5. Normal levels of carbon dioxide from respiration are 0.7 psi. This corresponds to a cabin partial pressure of 0.006 psi. The design of the carbon dioxide monitoring system will prevent the crew exposure to Acute Carbon Dioxide Toxicity. The design of monitoring system will detect carbon dioxide levels greater than 1% of the cabin pressure by partial pressure method. The carbon dioxide will be removed and controlled by the use of LiOH collection method initially in the base construction. As the base construction continues a Bosch reactor which disassociates the carbon dioxide into dense carbon and hydrogen. The hydrogen may be reacted with oxygen to produce potable water. As the base is advanced into the closed loop system, the carbon dioxide will be used for the horticultural research lab. The plants are expected to consume carbon dioxide at a rate which will keep its levels below 1% of cabin pressure by partial pressure (NASA STD-3000, 1989)

Regulated control

The control of the air quality will be designed as a self monitoring system with appropriate alarms and warnings which alert the crew to hazards.

b. Emergency depressurize

The particulate size of micrometeorites and the velocities they have, indicate that damage to the pressurized hull of the lunar base will take place. In order to protect against the damage caused by the micrometeorites, a system to pressurize the affected module will be designed.

Leak detection

The system will have to detect rapid pressure loss and be able to monitor the module pressure to give the crew indication of a slow pressure loss. The limits to indicate a rapid or slow pressure loss would be at a reduction of module pressure of 0.5 psi. This value will prevent spurious alarms from system variations during normal operations (NASA STD-3000, 1989)

Automatic/manual actions

The detection of the pressure loss will give warnings to alert the crew for proper actions to be taken. In the event of a rapid depressurization automatic closure of connecting hatches to other modules will take place. This will isolate crew members in the affected module. Due to the vacuum environment of the lunar surface, providing a method for crew members in the affected module to have a pressurized and breathable atmosphere is impractical. Crew members in the affected module would be assumed lost.

c. Water quality

The water quality required for the ECLSS system is extremely important. The actual water treatment system for the hygiene water must remove suspended solids and the bacteria in the water. The hygiene water will not be used for human consumption. The water quality for the potable water system will meet the requirements of the following table. The water collected from the condensation must be treated for bacteria to ensure the safety of the water for the crews consumption.

Treated water

All water will be treated. Water used in personal hygiene will be recycled after water treatment, into the hygiene water storage system. The potable water will be used directly from the water provided from earth. The potable water drains will be directed into the hygiene water storage system.

Bacteriological control

All water will be required to have water treatment for bacteria control. With the treatment, the time delay before use is 2 days. The waiting period is required for complete detection and control of bacteria growth. The water will be tested to ensure the effectiveness of bacteria control.

Taste/smell

The treatment of the water will not create any type of odor or smell which would make the water objectionable to use. The material selected for the water storage tanks will not induce any odors into the water. The taste consideration of the water will apply only to the potable water system.

d. Fire detection

The detection of fire will be of prime importance, not only for the fact that crucial equipment damage will be life threatening, but also the elimination of oxygen in the base will force demands on the atmospheric control system. The other safety considerations for the fire emergency would be the extreme smoke in the habitation spaces. Elimination of the fire source by early detection and extinguishing will prevent the associated dangers from spreading throughout the lunar base.

Detection

Detection of the fire must be early and correct. Spurious warnings or automatic control system actions would be deadly for crew members. The detection system will sound alarms based on elevated module temperatures at various locations in the module, an increase in the air born particulate levels associated with a fire. The detection system will alert crew members to take action to extinguish the fire. A time delay on automatic system functions such as sealing the effected module off and the expending of module-wide fire extinguishing chemicals. The time delay will allow the detection signals to be reset prior to the end of the time delay period. The time delay also allows crew members to manually over-ride the automatic control; system functions. This allows the crew to extinguish the fire unaided by the automatic systems.

Extinguishers

The automatic fire extinguishers that will be provided are water sprinklers in dry material storage areas and gas expulsion in all other areas.

Water sprinklers will be used automatically when sprinkler sensors detect local temperatures, at the sensors, above a safe level. The water sprinkler system will not have manual over-ride capability. The location of the sprinklers will be in areas where water damage to electronic and electrical equipment will not occur. The water source for the sprinkler system will be the hygiene water storage tank. This system will be a later development phases system.

The nature of the gas expulsion system is to remove all free oxygen from the space in order to smother and extinguish the fire. The system will be designed to ensure that no crew member is injured or killed by this system. The system will work in coordination with power removal from the affected space. This will allow electrical fires to be extinguished prior to use of the system. This will prevent the needless use of the system.

De-pressurizing the space would be a last resort method to extinguish the fire. This would occur in the event that crew members were unable to extinguish the fire without the use of automatic systems, the sprinkler system did not extinguish class a fires, the power removal did not extinguish electrical fires, the gas expulsion method did not extinguish the fire or the system failed. The depressurization method will remove all atmosphere from the affected module once it is isolated from the rest of the lunar base by isolation hatches. The result of the de-pressurizing would require re-pressurize prior to re-entry by crew members.

Prior to the implementation of the automatic systems, ample time will be given to the crew members to extinguish the fire by common methods.

The use of portable CO₂ fire extinguishers will assist in extinguishing small class a fires or the remaining fire left after an electrical fire. The ECLSS system will handle the increased levels of CO₂ in the module (NASA STD, 1989).

6. Productivity

To improve the productivity of the system, the overall systems will be incorporated together as much as possible to limit the number of components needed and the required power for the systems.

a. Minimize space used

Productivity of the ECLSS is based on the system performing its function in the smallest possible space. The ECLSS system will be installed under the flooring, in the module ceiling overhead, and in the outer walls of the individual spaces. In this manner, the systems will use much of the wasted normal inaccessible spaces and will not detract away from the useable compartment space.

b. Accessibility for maintenance

To improve the productivity of the system, the system components will all be accessible through either removable panels or removeable access plates.

7. Atmospheric Control

The atmospheric control will be based on maintaining the crew in a shirt sleeve environment.

a. Air temperature

The air temperature of all compartments will be designed to be maintained at 70 degrees F (NASA STD-3000, 1989).

b. Humidity

The humidity of the module will be maintained at a maximum of 40% relative humidity (NASA STD-3000, 1989).

c. Odors

Odors from fecal storage, humidity in the air, personal hygiene facility and from the food preparation area and the exercise area will all be removed by the ventilation system and its associated filters. The filters used to remove particulate odors will be activated charcoal filters.

d. Pressure

The compartment pressure will be continuously monitored and maintained by sampling the air and inducing or removing the correct amount of gas to restore the pressure level.

e. Bacteria

Bacteria will be removed from the ventilation system by heat and chemical treatment. Many of the obnoxious odors will be a result of bacteria. The removal of the bacteria will greatly reduce the odors and the health risk associated with bacteria.

8. Ergonomics

a. Control location

The locations of controls for each system will be located at eye level in most space or in a position which is the most convenient for operation by crew members in a specific space.

b. Adjustability

The supply and return duct damper control will be easily accessible and operable. The range of adjustment for each system will be sufficient to provide comfort and safety throughout the operating life of the lunar base.

c. Recognition of fittings

Each space will have controls present that are easily distinguishable and operable.

9. Storage

The water storage system for the ECLSS is designed to provide each module with a supply of potable and hygiene water so that isolation of a module does not restrict the operation of the lunar base water system.

The storage system for the lunar base water system provides the storage tanks below the main floor of the modules. This location provides for the application of irregularly shaped storage tanks. The location of the storage tanks below the module floor provides the module with adequate storage tank leak protection.

a. Potable water

The size of the potable water storage tank must meet the requirement of having enough volume to meet the 2 day water use during the initial water treatment system start up. Depending upon launch logistics, the size of the potable water storage will be sufficient to provide a 4 day supply of potable water. This is the expected amount to be received in the initial launch program.

The potable water tank is designed to operate with an internal pressure of 60 psi maximum when in compressed air back up mode. In normal operation the tank is vented to a pressure make up volume containing uncontaminated air. The material of the tank is an epoxy impregnated Kevlar composite material. The material is water proof and non-toxic. The interior of the tank will be lined to ensure containment of the water.

b. Hygiene water

The hygiene water storage tank is also located below the main floor for the same leak protection reasoning.

c. Waste water

Waste water storage tank materials criteria is the same as the potable water tank. The waste water storage tank has the requirement to be vented into the ventilation system and have fresh uncontaminated air supplied to it. This requirement is for control of bacteria and associated odors. The water stored in this tank will be urine and contaminated water from experiments.

H. Lighting Systems

Design Recommendations for a Lunar Base

The following are design considerations for interior and exterior lighting of the lunar space station.

When designing lighting for a specific space, it should be known what the atmosphere of the space is to be like; will it be cozy, restful, business orientated, viewing monitors, etc. Once the purpose for the space has been decided upon, the levels of intensity must then be ascertained. To obtain the correct levels, the illumination levels must be proper for vision and balanced against energy and initial cost. Efficiency is a major factor when determining a lighting source.

Lighting has an effect on many variables which influence the way a person views others, space, and themselves:

Lighting should complement the decor and color of a space.

Lighting should be used as a means of personalizing a space

Lighting should be sufficiently dispersed through all circulation routes.

Lighting should be designed for safety

Lighting not only aids in wayfinding and orientation, but it should illuminate areas to allow for differentiating between different textures.

Lighting should be designed to increase and encourage productivity.

1. Types of Lighting Available:

A. Fluorescent Light Sources

Fluorescent tubes create a high light output to that of power consumption.

Fluorescent light provides diffuse, shadowless light which provides better general illumination for vision; but makes viewing details difficult.

A cool-white deluxe fluorescent tube solves most of the problems with lighting in terms of proper color array with a better rendering index.

B. HID Light Sources

HID light should be used for general illumination of exterior spaces.
A positive point of HID light is that cost of operation is favorable.

D. Mercury and Sodium Vapor Light Sources

Both of these light sources are highly efficient with regard to amount of current consumed.
These types of light sources are most effective for the exterior environment too.
The light emission from a Mercury lamp is a bluish hue; and sodium is that of an orangish hue.

When selecting lighting for the interior of the habitation module, the lighting hue must also be kept in mind.

Select lighting colors that will support or enhance the interior of spaces and its objects.
The lighting chosen should not cause discoloration to the human complexion.
Red light should be employed where a person(s) must remain dark adapted. These areas might be a control room, command center, or even the EVA chamber.
Different spaces require different levels of lighting intensities. To achieve the appropriate intensity levels, there must be a control device of some type.
The intensity levels of light should not be so high as to cause any discomfort, (such as vailing reflections or glare),to those using the space.

2. Placement of Lighting Sources

The correct location of the light sources are crucial to the design.
The interior ambient light of the module should be diffuse light.
All lighting fixtures should be accessible at any time
Any ambient lighting fixtures should be placed at ceiling and floor levels. These locations will provide for the appropriate level of general illumination.
Lighting fixtures should have the ability to be erected and disassembled with common knowledge.
Lighting sources should be incorporated into the ceiling and floor or into the individual racks. This allows for easy maintenance.

There should be an assessment of the lighting needs for each space. There are three most important needs to be concerned about.

- A. Lighting for a specific task i.e. to provide adequate light that depends on good vision.
- B. A good lighting scheme relies on the ambient illumination of the space; i.e. a comfortable level of light to assist one in circulating through spaces.
- C. Special lighting for focusing attention onto specifics.

3. Distribution of Ambient Lighting

A. The ambient light should be indirect.

B. General lighting should be diffuse light

C. The lighting should not be concentrated onto a specific surface, but should wash the surface it is intending to illuminate.

Light is delivered in more than one way. Light can be concentrated, beamed from a light source, or diffused to scatter light in many directions.

Frosted globes or tubes disperse light in a diffused manor.

Light sources pointed toward a ceiling surface will deliver diffused light.

Concentrated light provides illumination for a specific task and detail work.

D. Beamed and Diffused Light

By using both beamed and diffused light, an area should receive the proper amount of illumination; thus preventing excessive lighting contrasts.

Task lighting should be provided at all work stations. Task lighting (or beamed lighting) provides each work station with the ability to perform detail tasks with greater efficiency.

E. CRTs or Monitors

Areas with CRTs or monitors will require a reduction in illumination. This will help reduce the possibility of glare and provide for better viewing.

4. The Psychological Implications of Lighting

Colors have a strong impact on human moods and emotions. Lighting not only effects an individuals mood, but also interacts with the perception of the spatial environment.

It is understood that warm light creates a sense of warmth and coziness; while cool light represents a feeling of reserve, formality, and sensation of coolness. The following hues should be considered when dealing with interior lighting:

A. Reds

Reds are warm, exciting, and stimulating. They are associated with tension and danger. By carefully augmenting reds with other colors in a scheme, it is possible to achieve life and cheer.

B. Orange

Oranges share the same qualities as reds with some slight modification.

C. Yellow

Yellow is the mildest of warm colors, it represents cheerfulness and humor. Yellows provide strong brightness with less tension than that of reds or oranges. Some yellow tints suggest safety with no negative implications.

D. Green

Greens help balance spaces seeking to be calm and restful, peaceful and constructive. Green remains a good color to promote serenity, it helps to counter any sense of drabness.

E. Blue

Blues are the coolest of all hues, they suggest rest, repose, calm and dignity. But, blues have the tendency to create gloominess and depression when used too often in a space.

F. Neutral Colors

Neutral colors like those of grays make good background colors that are easy to live with for long periods of time. Grays can be monotonous but when used with other colors can be successful.

G. White

Whites and near whites represent brightness, openness and clarity. White is a safe hue and can be used in large denominations. It also suggests cleanliness and sanitary views.

5. Controlling the Lighting and Fixtures

There must be some type of switching to control the output of each fixture. Switches should be generally located within the spaces. There are a number of switching options available. They range from remote locations, central panels, multiple switches, and switches controlled by timers, clocks, or light sensors.

Lighting fixtures can also be controlled by heat or sound sensitive switches.

Proximity switches turn luminars on when a person is present in a space, and off when the person leaves the space.

If a space has one or more entries, than a switch should be positioned at each entry. Switches for ambient lighting should be located 50 inches above the floor. Any lighting controls should be illuminated for easy identification. Lighting controls in sleep quarters should be located within arms reach from the sleeping restraints.

Multi-level Lighting Switches

Multi-level lighting is another option that provide greater flexibility. They allow lighting levels to emit either lowest or highest output of illumination.

Dimmer switches should be used in areas that require flexibility in lighting levels.

Dimmer switches allow fixtures and lamps to have the maximum number of running hours.

6. Exterior Lighting Recommendations

Lighting for the base exterior should be bright enough to be seen through a dust cloud, etc. Lighting should have color - this will allow for easy identification of specific areas.

Exterior lighting fixtures must be reliable, durable, have long life expectancies, and minimal maintenance.

7. Lighting Requirements Formulas

To help in selecting the appropriate lighting fixtures in terms of energy consumption, the following formulas are provided.

This formula concerns itself with energy consumption and the floor area to be illuminated. It will also provide us with the watts per square foot.

$$\text{Total Wattage of Lighting} = \frac{\text{Watts/Sq. m}}{\text{Floor area in Square meters}}$$

Before specifying any fixtures, lamps, etc for a space, a number of calculations must be done. The following calculations help to select the appropriate hardware to be used. The number of footcandles for a space must be determined for the appropriate task. To find the correct number of footcandles (f.c.) use the following.

$$\text{Footcandles} = \text{Lumens} / \text{Sq. M of Area}$$

In addition to the number of f.c., calculating the placement and location of fixtures is important. With the following formula finding the level of illumination, the number and spacing of fixtures is possible.

$$\text{Illumination} = \text{lumen per watt} \times \text{CU} \times \text{lamp depreciation} \times \text{dirt} / \text{sq. m of the area}$$

Note: CU refers to coefficient of utilization

The preceding formula not only determines the desired level of illumination, but will also find the area that a fixture is possible of illuminating. To determine the wattage use the following:

$$\text{Wattage} = \text{Lumens per Watt} / (\text{sq. ft. of area}) \times (\text{f.c.})$$

Finally this formula provides the number of fixtures for a space:

$$\text{Square Feet} = \text{number of fixtures} \times \text{sq.ft. of area covered by each fixture}$$

The preceding are design considerations for the interior and exterior of a space station base and module on the lunar surface. The design criteria are recommendations and are therefore subject to any alterations. These recommendations should provide optimum levels of illumination.

I. Thermal Control Systems

1. Room Temperature Requirement

a. General requirement

The room temperature for a general use should be 23 to 24 degrees Celsius (NASA STD-3000, 1989)

b. Temperature for an adult over 60 years of age

The temperature for a crew whose age is over 60 years old is 0.6 Celsius higher than the temperature for the younger.

2. Humidity Requirement

General requirement: relative humidity should be between 30 to 50 % (NASA STD-3000, 1989).

3. Sensors for Internal Environmental Control

a. Temperature

Temperature will be measured by a thermocouples in the air.

b. Humidity

Humidity will be measured by a thermocouples in the water.

4. Method for Internal Environment Control

- a. Type of heat exchanger
A finned-tube exchanger will be used.
- b. Noise Requirement for Heat Exchanger

5. Cooling System for Day

Method: the module will transfer heat generated to the outside through heat exchangers
This process continues 14 days.

6. Heating Systems for Night

Method: thermal energy stored at day will be stored in a thermal sink for night. This process continues 14 days.

7. Place of an Radiator

The ground should be flat for a radiator to be stable. Pipes will be buried under the ground.

8. Heat Exchanger Requirements

Capacity : It can transfer heat whose amount is 3403 Joule/second.

Type of Heat Exchanger: Finned-Tube type, which is categorized as a compact heat exchanger will be used.

J. Material Storage Systems

1. Coding

The storage system should provide the crew members with equipment and compartment identification.

It is important to be able to differentiate between the different materials being stored:

- a. Uniform coding
- b. Use of color, symbols, numbers, and letters
- c. Simple to use, easy to memorize
- d. Ability to adapt to change, and reconfiguration
- e. Mapping of locations:
map or chart with the location and symbols of each item

2. Health and Safety

Containers should prevent any hazardous materials from being released into the atmosphere.

Must prevent the spread of radiation.

Crew members must be able to keep their balance while getting things out of storage.

- a. Physical separation of samples from other base components
- b. Secure lids
- c. Handles and grasps

3. Atmosphere

The storage system itself must prevent the escape of radiation from any of the samples
Prevent the release of hazardous gases or chemicals used in experiments.

Should have an alarm system within the storage system to announce the escape of hazardous gaseous matter:

- a. Atmospheric monitoring
- b. Monitoring system

The monitoring system should be able to identify each organic compound and take measurements at regularly scheduled intervals

4. Ergonomics

Crew members must be able to adjust to their environment

Work conditions must suit workers:

- a. Easily understood coding system
- b. Mapping or color guide posted near the storage rack to make accessibility easier
- c. Proximity to the areas where storage items are being used

5. Lighting

Lighting for specific tasks should be considered for locating small objects or for specific storage purposes.

General lighting must be provided.

K. Waste Storage Systems

1. Materials

Materials selected for storage and transfer systems of wastes must be able to withstand temperature and pressure cycling as well as possess nonreactive properties to the various substances they will come in contact with: chemical, urine, fecal wastes and general trash. The interfacing systems must also be easily cleaned and sanitized.

2. Health/Safety

Collection sites at the point of origin must be able to contain the wastes in a sanitary manner. Disposition systems must be designed to avoid physical harm in the processing of the wastes: chemical mixing, vacuum drying, freeze drying, shredding, and incendiary. Storage systems must be located in areas easily accessed by transfer systems both internal and external to base habitats.

3. Atmosphere Control

Within these systems temperature and pressure must be monitored. The atmosphere control system must be able to evacuate dangerous levels of toxic fumes or unpleasant odors that escape or accumulate at the points of origin.

4. Coding

Instructions on the use of the collection, storage and disposition systems must be clearly communicated to multinational personnel.

5. Productivity

The initial collection sites, transfer systems, disposition systems and storage systems must be integrated efficiently with routine tasks and must not be too all consuming in time

demands. This would suggest decentralized collection of nontoxic trash to be gathered for final disposition and processing as local containers become full with local personnel responsible for transfer to central storage area. Human wastes can be processed locally with some mass reducing or dehydration system and transferred on a scheduled basis or transfer systems can be developed to collect wastes as created and centrally stored for processing or reclamation.

6. Ergonomics

Personal interface systems must be designed to adequately serve multinational and gender needs.

7. Proximity

Collection sites and processing stations must be efficiently linked to promote timely and safe disposition of wastes and trash. The storage system must also be efficiently linked between the processing station and landing site for final disposition which may entail return to earth. As suggested earlier the storage system could be converted empty logistic supply modules which would be stored in the unpressurized warehouse. Alternatively the processing station could be located at the logistic interface to allow shirt sleeve operation of processing and have the converted module docked to the processing station.

III. Mission Operations: Experimental Systems

Introduction

A lunar science and technology facility is needed to create a scientific, space transportation, and industrial infrastructure to support exploration of space and the other planets. Research on the moon can also provide new information about human behavior, the formation of the solar system, and evaluation of potential use of lunar resources for supplying a lunar base, space station, or spaceships destined for Mars and beyond, as well as a source of energy (helium-3). Scientific and technological benefits of a habited lunar base include:

1. Surveys of lunar resources and extraction/processing methods: Lunar surface mining and production analysis.
2. Construction technology testbed.
3. Plant growth: Closed system ecological life support system experiments.
4. Planetological studies of the solar system's origin and features, and physics/astrophysics/astronomical research in a high vacuum environment: lunar-far side observatory.
5. Human factors and environment-behavior systems research.

These science missions would take advantage of the moon's unique environment: (a) high vacuum, (b) low gravity (1/6 of Earth), (c) regolith composition, (d) isolation, (e) low seismic activity (when compared to Earth), and (f) low magnetic field.

A. Laboratories: General Design Requirements

There have been basically two approaches to laboratory design for space missions: the dedicated facility approach and the open plan approach. In the dedicated facility approach, a specialized facility is provided for each general field. This approach provides a number of advantages (Batelle, 1987): (a) dedicated space to allow a series of focused experiments, (b) availability of dedicated facilities and equipment which are tailored to the discipline of interest, and (c) physical separation from other science experiments and base operations (Batelle, 1987).

The open plan approach has been most commonly used, since space and manpower is limited.

Design Recommendations:

The dedicated facility approach would seem to be the most suited to lunar applications, not only for the advantages listed above, but also for the simple reason of controlling dust from geochemistry and petrology experiments and construction technology research.

1. Laboratory Facility Breakdown

The general laboratories for this base would be:

- a. Lunar surface mining and production analysis: geochemistry/petrology lab

This laboratory would provide facilities for the study and experimentation of lunar resources and extraction/processing methods (mining and resource utilization), as well as for the study of the origins of the moon and the solar system.

b. Space construction technology testbed

This facility would test materials, both lunar and earth-based, and methods for advanced space construction.

c. CELSS testbed

Experiments would take place focusing on plant growth and closed-loop ecological system development. Capabilities in biochemistry, analytical chemistry, cell biology, plant physiology and microbiology would be needed.

d. Far-side lunar observatory and astrophysics station

Workstations may be required to monitor the performance and collect data from a Lunar Far-side Observatory. A solar observer, which would monitor solar flare activity, should be given high priority as a safety measure protecting the lunar base inhabitants from extreme radiation.

e. Human factors/environment-behavior systems monitoring research facility

Experiments focusing on the adaptation of humans to isolation and reduced gravity would be an early part of mission operations activities. In addition, this facility would monitor cardiovascular de-conditioning, bone calcium loss, and muscle atrophy in crew members, as well as monitoring habitat environmental factors such as radiation, water quality, microbiology, toxicology, and barothermal physiology.

2. General Design Criteria**a. Volumetric requirements:**

The required volume for specific laboratories will depend on the equipment used and the scope of the investigations taking place.

1. Equipment
2. Workspace
3. Circulation
4. Design recommendations

Area is to be provided as a workspace for note taking, analysis of tests, sample preparation, and the setting up and tearing down of equipment.

A 4'-6" minimum clearance for circulation should be allowed, plus additional area for starting and stopping in 1/6 gravity (SICSA,1989).

b. Anthropometrics

1. Workspace height/configuration
2. Design recommendations

Standard anthropometric sizings should be followed, such as those found in NASA STD-3000.

c. Coding:

Should be used such that it will facilitate the quick identification of elements under both normal operational and emergency conditions.

1.) Design recommendations:

- (i) Identify the facility
- (ii) Identify experimental apparatus and location
- (iii) Identify if possible dangers exist
- (iv) Identify emergency systems and exits
- (v) Coding should be readily identifiable without need for reading
- (vi) Either color or graphic symbols or a combination of both should be used

d. Proximity

Facility arrangement, grouping, and layout should promote efficient and safe operation. Proximity relations can be determined by the crew tasks and operations in the labs, including:

1. Frequency
2. Duration
3. Sequence
4. Volume required
5. Special environmental requirement
6. Design recommendations

Minimize transit time between related activities, accommodate the expected levels of activity at each area, isolate areas when necessary for crew health, safety, performance, and privacy.

e. Wayfinding

Geometrical arrangement of spaces within the habitat may influence its legibility and the ease or difficulty one experiences finding one's way within it; health and safety concerns dictate the need for clear orientation, especially in areas where possible dangers exist.

1. Location of facilities
2. Locations of exits/entrances
3. Location of equipment and work spaces
4. Location of emergency systems
5. Design recommendations: Logical location of elements with respect to historical or hierarchical arrangements should be preserved.

f. Color/decor

1. Color and decor are important visual and tactile stimuli which affect crew morale.
2. Aesthetic and psychological requirements
3. Flexibility
4. Design recommendations: Color and decor should not be overly complex nor should it be overly simple; decor which can be modified would be an added amenity, and wherever possible the decor should also serve as a location coding, noise reduction (texture), or glare reduction function.

g. Materials

Material selection is especially important in laboratory facilities, where they must resist the wear and tear associated with experimentation.

1. Cleaning
2. Contamination
3. Repair
4. Texture
5. Durability
6. Design recommendations:
Materials should be durable enough to withstand abrasion, scratching, and corrosive contaminants, and be easily cleaned and maintained; they should also provide for added traction, noise reduction, and glare reduction where possible.

h. Atmosphere control

Certain experiments may require special atmospheric conditions, as well as provisions for dust control or a seal-off ability.

1. Temperature
2. Humidity
3. Circulation

4. Filtering
5. Seal-off ability
6. Design recommendations:
Each facility should have its own atmosphere control capability, to insure experimental response and crew safety.

i. Light requirements

Thermal and lighting provisions should be responsive to the needs of scientific experimentation:

1. Color of light source
2. Intensity
3. Placement of source
4. Distribution of light
5. Character of task
6. Design recommendations:
A general lighting system should be provided, as well as task lighting for specific functions.

j. Sound transmission

Experimental apparatus such as a thin section maker and polisher may produce noise which could be subversive to other experiments or irritating to humans, therefore a special steps must be taken to control noise from both entering and emanating from the facility:

1. Extreme noise
2. Extended exposure
3. Communication inference
4. Task interference
5. Intermittent noise
6. Psychological effects
7. Design recommendations:
Materials which dampen noise should be used, and apparatus which produce high noise levels should be given special provisions to control sound transmission.

k. Health/safety

Experiments may take place, or materials used, which may cause harm to crewmembers should an accident occur:

1. Mechanical hazards
2. Contamination
3. Fire
4. Pressurization failure
5. Thermal touch
6. Auditory
7. Electrical
8. Locomotion in 1/6 g
9. Design recommendations:
Since any harm to crewmembers could be potentially catastrophic, every precaution should be taken with experimental equipment. Facilities should have a seal-off ability, back-up lighting systems should be provided, safeguards installed near heavy equipment, and safety systems such as fire suppression systems installed.

I. Productivity:

Mission operations refers to the experimentation and development aspects of the habitat, therefore productivity is a major issue, especially at an early lunar base where manpower, time, and resources are limited.

Design Recommendations

- (i) Equipment and facilities responsive to human interface
- (ii) Safe, efficient, and comfortable work and living environment
- (iii) Minimize transit time between related activities
- (iv) Accommodate expected levels of activities

B. Lunar Surface Mining and Production Analysis Facility

1. Size

The facility should be large enough to house a flow bench, a scanning electron microscope, storage sample racks, counter space sufficient for experimental apparatus and note taking.

Two smaller rooms, an acoustically isolated sample preparation room large enough to house a thin section maker and a "clean" room which can provide a pristine environment for the study of lunar samples, should also be provided within the facility.

A small pilot plant for the extraction of oxygen from lunar soil will most likely be present, necessitating storage space for raw lunar material.

Processing experimentation will be varied, and may include fluidized bed reduction, sintering using microwave plasma, and solar melting. Apparatus will likewise range from superconducting magnets and microwave generators down to particle size sorters. Therefore the size and overall configuration of this facility must meet storage requirements for equipment, as well as be flexible enough to allow for efficient and safe set-up and tear-down of experiments.

2. Atmosphere

Dust control will be extremely important within this area, since not only will large volumes of regolith be present, but experimental apparatus and sample preparation may produce dust in their operations, contaminating not only the atmosphere but also other experiments. Therefore, each piece of equipment should provide some means of dust filtering, and the larger dust-producing machines should be placed within an environmentally isolated room.

Humidity should be very low, since the presence of moisture in the atmosphere may affect the results of some experiments.

3. Day-to-Day Operations

Various experiments may be occurring simultaneously and available staff will be limited, therefore tasks such as sample preparation and experiment monitoring should be automated to the highest degree possible. In addition, tasks which produce dust or pose possible dangers should be automated wherever possible for safety reasons.

4. Lighting

An overall illumination system which is adjustable is recommended, supplemented by high degrees of specialized task lighting.

5. Health and Safety

Both mechanical and chemical hazards exist, thereby necessitating the presence of first aid capability within the lab to treat cuts, contamination, or possible eye injuries.

6. Location

To minimize the transport of regolith samples through the habitat, this facility should be located near an airlock, or perhaps have an interface large enough for the transfer of samples to an airlock.

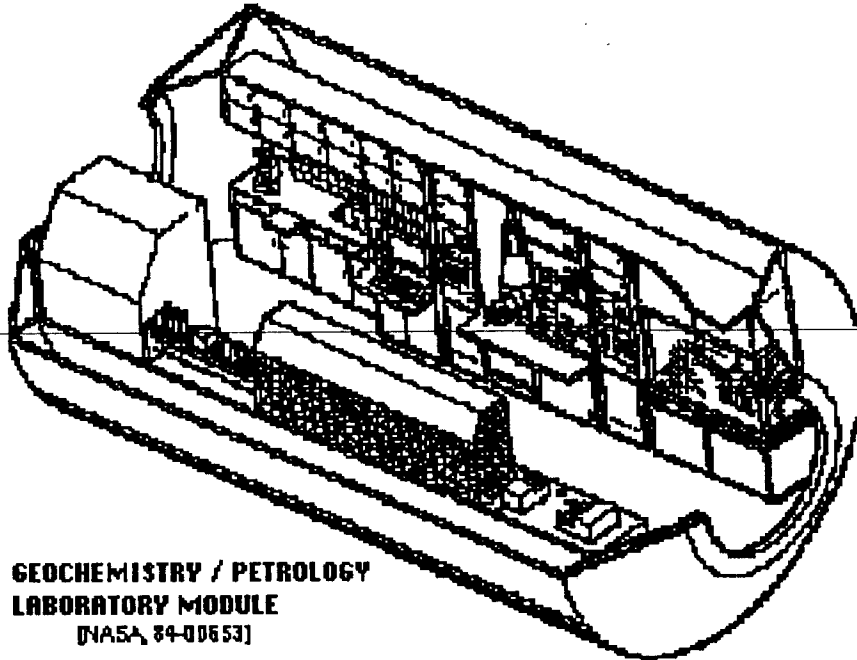

**GEOCHEMISTRY / PETROLOGY
LABORATORY MODULE**
[NASA, 84-00653]

C. Construction Technology Testbed

1. Size

The testbed may be comprised of a number of facilities, ranging from a material development laboratory to a material testing and deployment area.

Facilities for the development and production of materials in this initial base should be coordinated with the Lunar Surface Mining and Production Analysis Facility, since the two may share similar apparatus and processing techniques.

A facility for the testing and deployment of products will require an interior pressurized facility free of obstructions to allow for the erection of members, as well as a small isolated chamber in which to initially stress test and monitor materials under controlled conditions.

A nearby exterior area isolated from traffic should be provided for the testing of the lunar environment upon structural materials.

The geotechnical testing of various siting strategies will be an EVA task.

2. Health and Safety

Provisions should be made to monitor the possible outgassing of processed materials within a controlled environment before they are exposed to the atmosphere of the habitat.

Injuries caused by sharp members, accidents with tools and chemicals, or the unexpected failure of an experimental structural member pose serious threats to crew health. First aid within all testing areas should be provided, as well as fire suppression equipment.

3. Location

The testing facility would most efficiently be placed near the Lunar Surface Mining and Production Analysis Facility, to minimize traverse distance between development and testing areas, as well as near the Maintenance Facility, for the sharing of tools and related equipment.

D. CELSS Research Facility

1. Size

A. Test Facility

The facility should be large enough to house at least one complete set of plants in table

In the initial phases of the Biosphere, the scale of the facility should start and remain small until plant productivity, contamination safe-guards, and human safety are proven.

The facility should have a non-toxic atmosphere for easy human operations.

Aeroponics should be the method the facility would use to grow the plants. This method moves plants on a conveyor belt through areas where they would be sprayed with a fine nutrient solutions (Polette,1988)

B. Full Scale (Food Source)

The facility must be large enough to supply the entire crew with their daily dietary requirements.

The facility must also be large enough to produce an emergency supply of food. and must be large enough for the separation from the warm and cool crops to maximize plant productivity.

Cells Design Components (Polette,1988)

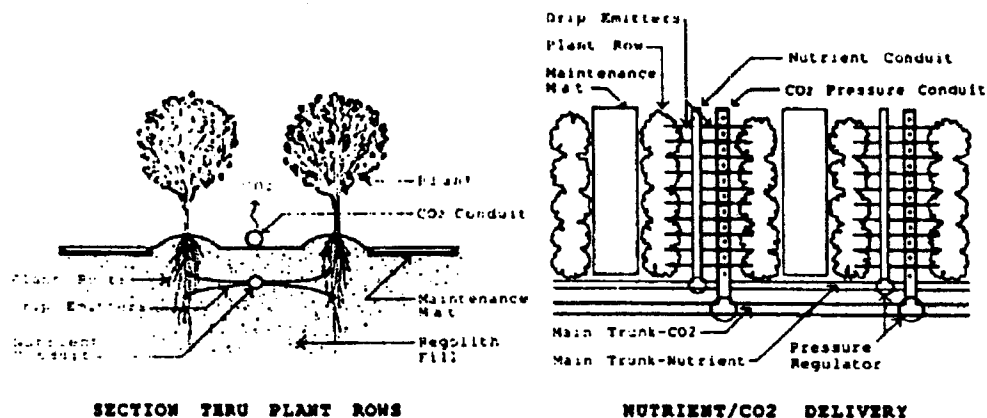

The facility must include a growth chamber, systems equipment module, mechanical processor, and storage areas.

The facility must have several complete sets of plants to ensure against contamination that could destroy the entire crop.

The facility should have both plant and aquatic organisms.

The facility should have automatic or robotic systems to maintain day-to-day operation to allow the crew to run other base operations.

The facility should have the capabilities of either method; hydroponics or aeroponics. This should depend on if there is any differences on plant productivity and/or overall labor hours involved.

2. Plant Productivity

The plants should meet or exceed their edible weight per plant in Table 1 in a normal atmosphere.

Plants that are grown in altered atmospheric, temperature, carbon dioxide, and humidity levels must exceed their productivity levels under normal conditions to warrant the change.

3. Atmosphere

A. Non-Toxic

The facility must be sealed off from the rest of the base due to the different levels of humidity, and temperature.

The facility must have an airlock to guarantee against plant contamination from the habitation or laboratory module.

The facility must have its own HVAC so it will not overload the habitation or laboratory module's HVAC.

B. Toxic

The temperature, carbon dioxide, atmospheric, and humidity levels are changed to maximize plant productivity.

The facility must have an airlock to guarantee against plant contamination from the habitation or laboratory module.

The facility must have its own HVAC so it will not overload the habitation or laboratory module's HVAC.

The facility must have a EVA/preparation area for those with lower atmospheric pressure or higher levels of carbon dioxide.

The facility must have a detection system to guard against leaks into the laboratory or habitation modules and mechanical failure.

4. Organisms

A. Plant Type

The plants used are in the following table and were chosen for their dietary considerations and edible weight per plant.

	VEGETABLE CROP	OPTIMUM GROWING TEMP (C)	ROOT DEPTH (M)	DAYS TO HARVEST (DAYS)	CANOPY AREA PER PLANT (SQ. M.)	EDIBLE WT. PER PLANT (GRAMS)
WARM CROPS	TOMATO	21.1 - 23.9	1.2 +	110 - 155	0.418	8333.3
	WHITE ONION	21.1 - 26.7	.38 - .46	185 - 180	0.023	365
	BELL PEPPER	15.5 - 23.9	.91 - 1.2	105 - 135	0.139	787.5
	PINTO BEAN	23.9 - 26.4	.91 - 1.2	45 - 65	0.023	62.6
	SNAP BEAN	23.9 - 26.4	.91 - 1.2	45 - 65	0.023	62.6
	ZUCCHINI	15.3 - 26.7	.91 - 1.2	60 - 70	0.557	3023.9
COOL CROPS	KALE	-1.1 - 18.3	-	40 - 50	0.118	208.1
	SPINACH	15.5 - 18.3	.61 - .91	40 - 50	0.018	195.8
	CABBAGE	15.5 - 18.3	.48 - .61	90 - 150	0.166	1046.8
	BROCCOLI	15.5 - 18.3	.48 - .61	70 - 150	0.155	588.2
	CAULIFLOWER	10.0 - 18.3	.48 - .61	148 - 222	0.217	1864.8
	POTATO	15.5 - 18.3	.48 - .61	90 - 120	0.174	877.9

Data obtained from Coy and Niles, 1972

Table 1. Plant Growth Characteristics

(Polette,1988)

B. Aquatic Form

The aquatic stage will be implemented in the later phases of the biosphere due the amount of water that is required.

5. Lighting Systems

The facility should use cool fluorescent lamp lighting, as the main lighting source, that would provide an illumination of 7,000 lux on the plant (Polette,1988).

The facility would also use fiber optics to utilize natural sunlight.

6. Configuration

A. Expansion Capabilities

The facility should have ability to expand with the addition newer phases of the biosphere and the overall base growth without any major reconstruction. (See figure

B. Plant Redundancy

The facility/facilities must separate the sets of plants to ensure against total crop failure in case of an emergency.

7. Phasing

A. First Phase

The first phase should consist of a small inflatable test facility with a small number of plants to ensure growing techniques.

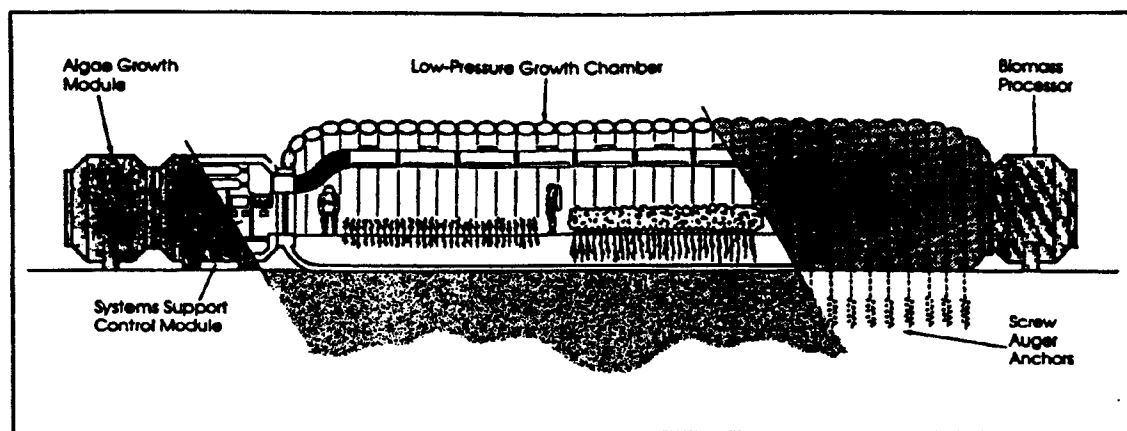

Longitudinal Section Through an Initial Stage Inflatable Facility

B. Second and Third Phase

The second and third phases would include many facilities to produce a enough food to support the entire crew over long a duration.

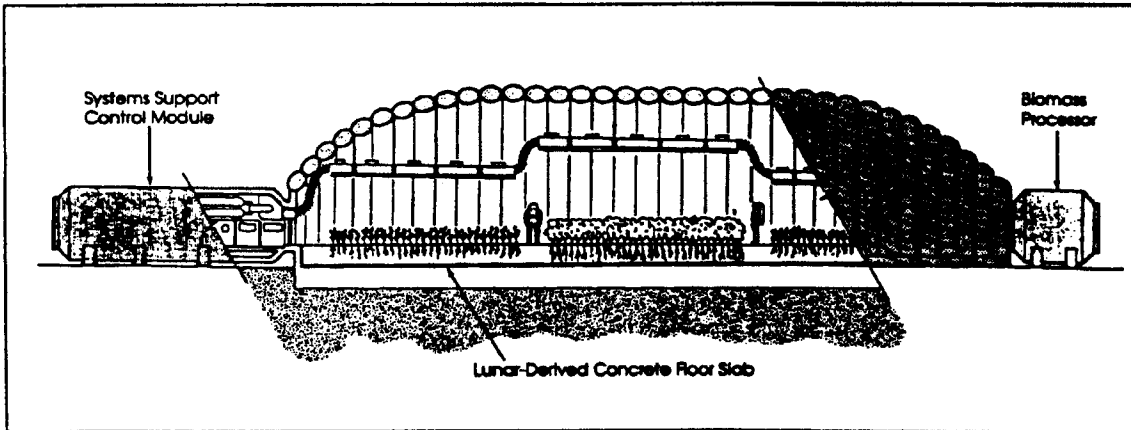

Longitudinal Section Through an Advanced Stage Inflatable Facility

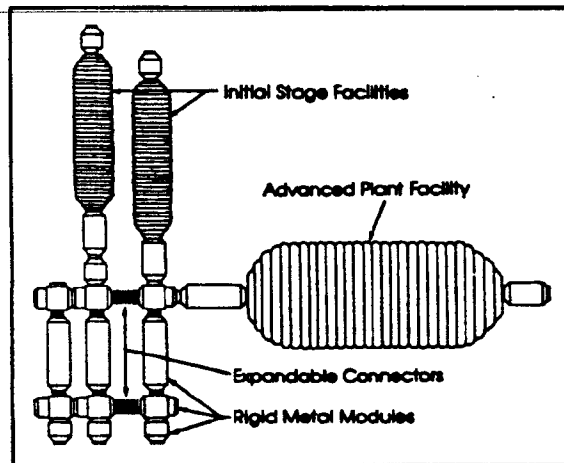

Plan Configuration Concept

(Polette,1988)

E. Far-Side Lunar Observatory

1. Size

Design recommendations: Since information from a far-side observatory would most likely be transmitted directly to Earth, a single workstation would most likely be adequate. This workstation may also be monitoring solar flare activity.

2. Location

Design recommendations: Since the most pertinent information would be regarding solar flare activity, and this would be a base concern, this workstation would most likely be located in the base operations area.

3. Lighting

Design recommendations: Any astronomical workstation should be provided a dark environment so as to maximize the display capability of the visual images.

F. Human Factors and Environment-Behavior Systems Monitoring Research Facility

1. Purpose

The purpose of a human factors (HF) and environment-behavior systems (EBS) monitoring and research facility is derived from the essential mission of a lunar habitat – as a later Martian exploration. Thus it will be critical to monitor and test human reactions to all aspects of the base, to the functions, to the habitat, to the command module and functions, to EVA, etc. The HF/EBS Research Facility will be the heart of these monitoring and research functions.

2. Location/Proxemics

The HF/EBS Research Facility should be near both the habitat, the other research areas, the command module, and EVA doff/don areas. It thus should be relatively centralized in the total lunar base. As it will primarily be a telecommunications research facility, it could be adjacent to or a part of other research facilities and/or the command center.

3. Size/Configuration

The HF/EBS Research Facility will monitor all base human-environment interfaces through five primary research methods:

1. Telecommunication monitoring (e.g., from the exercise or health maintenance areas).
2. Systematic observation (e.g., of social interactions in different types of spaces).
3. Surveys (e.g., ongoing time/space logs and electronic data processed questionnaire formats of activities and reactions in the recreation areas, eating areas, etc.).
4. Open-ended interviews (e.g., of reactions to different arrangements of the private quarters).
5. Focus groups of the whole (e.g., in the group recreation area).

Most of the research will be conducted in situ, where the actual environment-behavior transactions are taking place.

The primary needs for the research "facility," therefore, will be one telecommunications workstation (equivalent to one SSF workstation rack) with sufficient monitoring devices to record all of the research being conducted, a hook-up to the central computer for real-time analysis, and storage for any materials which might be administered as questionnaires (though it is assumed most of this will be computer driven and stored).

A standard 1.35m clearance for circulation should be allowed around the workstation.

3. Anthropometrics

Standard anthropometric and ergonomic design considerations should be given to this workstation as the operator may be there for significant periods of time coding and analyzing data to give timely feedback to the base and to Earth control about ongoing base activities and human reactions.

IV. CREW SUPPORT HABITAT

A. General Design Requirements

Critical to the physical, social, and psychological needs of the crew members, will be the crew support habitat. It will be an environment responsive to group interaction, and simultaneously responsive to privacy. Considered a "home away from home," it will employ "Earth-like" amenities as well as basic necessities in the form of: personal quarters, hygiene facility, laundry facility, recreation area, medical and exercise, and meal preparation. It must have the capacity for easily-integrated expansion as the lunar base matures and mission duration increases.

1. Anthropometric / Ergonomics

a. General criteria

Every item of the habitation facility will need to conform to the human body. Care must be taken when placing equipment or controls so that they are accessible to all users of the base. Chairs, beds, desks, etc. must be designed consistently with respect to sizing and proportion. Where applicable, it would be wise to have adjustable equipment which provides instant adaptability of the object to the user. Generally equipment found on Earth will be usable on the lunar surface. Keep in mind that weights decrease by 5/6; therefore, the mass and structure of furniture can likewise decrease. Another general consideration is that the users will be bounding when walking due to the reduced gravity.

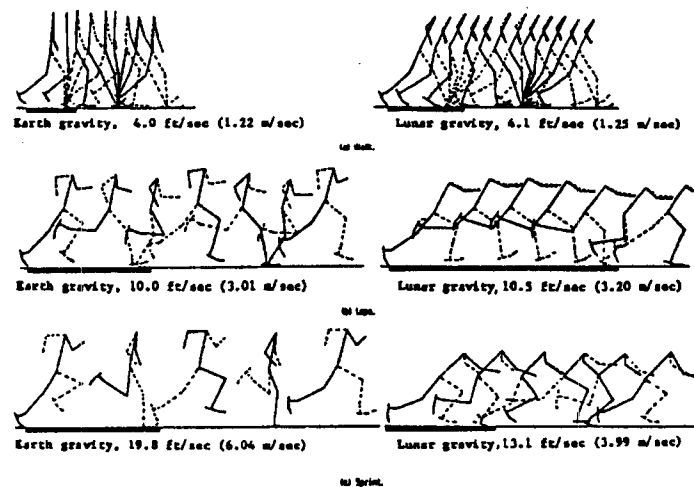

Body Inclinations (Hewes, Spady and Harris, 1966)

and the overall strength of the muscles which are conditioned for a 1 gravity environment. The tendency will lessen as the inhabitants become familiar with the 1/6 g environment.

b. 95% male/5% female

NASA-STD-3000 provides a great amount of information concerning anthropometrics, sizing, reach, etc. The designer of lunar facilities should familiarize themselves with the data in the NASA Standards. The data provided is broken down into the 95% American male and the 5% Oriental female. These parameters take into account the diversity of the human race and how it should be designed for in space. Where reach is an issue, the shortest measurement should be used (5% female) and where clearance is an issue, the largest measurement should be used (95% male). Provided in the following figures are standing and sitting data found in the NASA Standards and other sources.

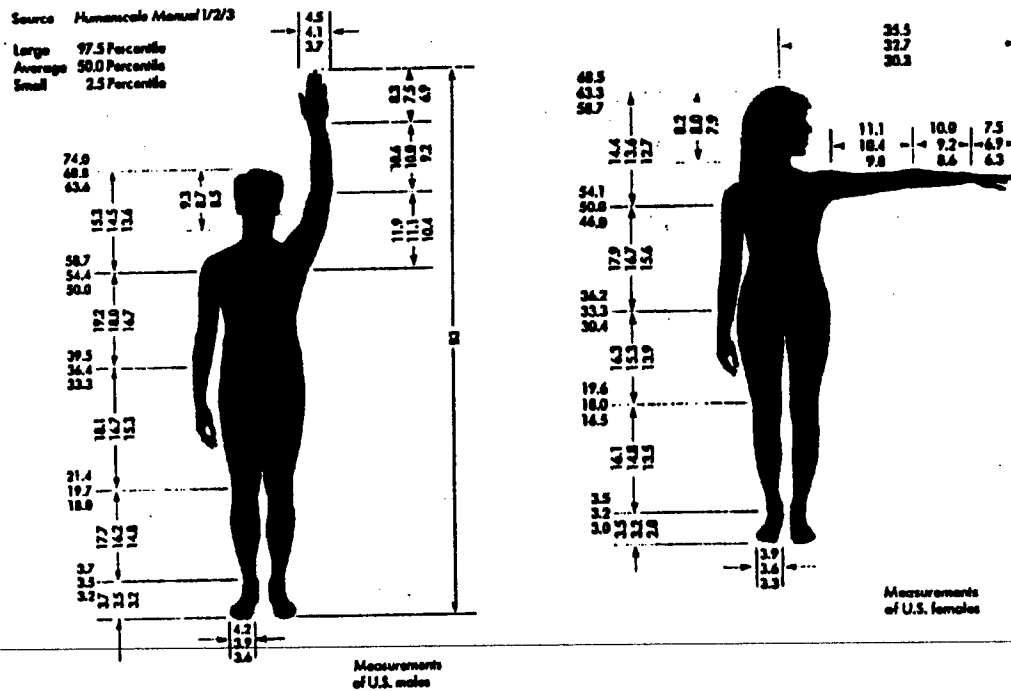

c. NASA Standards

Other information contained in the NASA Standards is the Secular Growth information and charts on how the body physically changes during space missions. While this may not have immediate impact on designing now, decades later when the lunar base is still in operation the equipment may no longer fit!

2. Safety

- Crew safety will be a priority issue for all designs.
- Included in this consideration will be primary features for two areas:
- Design-induced crew error
- Systems failures

3. General Design Considerations

- When considering safety, human behavior must be addressed. Human error can be committed during operation and maintenance of equipment. Designs should be created to lower the probability of error due to:
 - exceeded physical and psychological human limit
 - increased physical requirement resulting in fatigue
 - inadequate facilities, improper information
 - complex and unpleasant tasks resulting in insufficient time allotment and attention
 - tasks being inherently hazardous
 - crew modification of insufficient equipment
 - incomprehensible, inaccurate procedure
 - unsafe use by crew member
 - lack of warning label or management technique, lack of proper instruction or training
- Anticipating equipment misuse and design to reduce misuse resulting in catastrophe.

c. Anthropometrics

Interior dimensions must be able to support two crew members in the translation paths with space suits donned. This is considered in case of emergency depressurization.

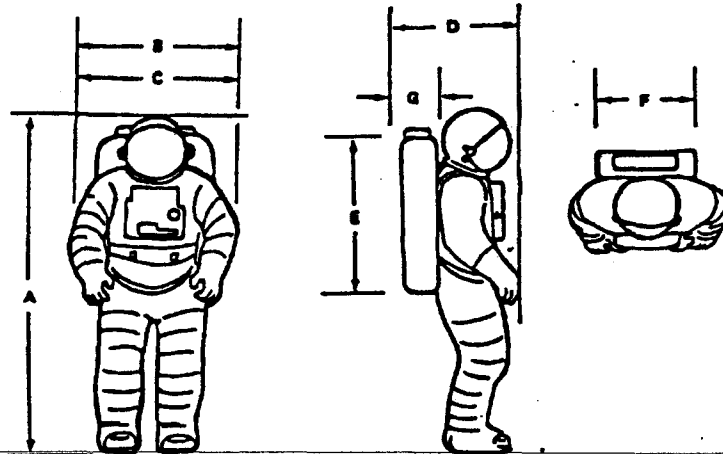

	Size range	
	5th Percentile Female	95th Percentile Male
A - Height	171.5 cm (67.5 in)	191.8 cm (75.5 in)
B - Maximum breadth at elbows (arms relaxed)	-	84.8 cm (33.4 in)
C - Maximum breadth at elbows (arms at side)	-	66.0 cm (26.0 in)
D - Maximum depth with PLSS/SOP	66.0 cm (26.0 in)	68.6 cm (27.0 in)
E - PLSS height	81.3 cm (32.0 in)	
F - PLSS breadth	58.4 cm (23.0 in)	
G - PLSS depth	17.8 cm (7.0 in)	

4. General Safety Design Requirements

a. General safety system and crew safety to minimize human error potential.

b. Fail-safe design

System should tolerate some failure without damage, crew injury or undesirable operating times.

c. Eliminate and minimize hazards by:

1. proper design
2. remove crew from hazardous interface, i.e. remote manipulators
3. guard against sharp edges, pinch points, etc.
4. warn, i.e. labeling

d. Four Main Areas of Concentration

1. Mechanical:

Elimination of burrs, corners, edges, protrusions, pinching, snagging, cutting possibilities (see NASA STD 3000 Section 6.3.3-6, subsections a-e).

2. Electrical design considerations:
 - principle electric hazard is shock resulting in burn or injury to nervous system
 - bio-instrumentation separate design consideration
 - consider total environment to eliminate electric shock
 - provide adequate isolation of bio-instrumentation system from ground.
3. Electrical hazards design requirements:
 - voltage/current frequency limits (see NASA STD 3000 Sect. 6.4.3.)
 - Crew member protection:
 1. grounding
 2. protective covers
 3. interlocks
 4. warning labels
 5. warning label plus recessed connector
 6. plugs, receptacles (see NASA STD 3000 Sections 6.4.3.)
 7. insulation
 8. power cords (see NASA STD 3000 Section 6.4.3.)
 9. moisture protection
 10. static discharge protection
 11. spacing between connectors
 12. bio-instrumentation system shock protection

4. Thermal Hazards
 - Thermal hazard design consideration shall depend on temperature of surface to be touched
 - duration of touch
 - thermal control degree
 - finish of surface
 - force of contact
 - size of contact area
 - diffusive of surface touched
 - touch temperature design requirements (NASA STD-3000,1989):
 - bare skin continuous contact (design goal of 40 degrees C , 104 degrees F)
 - bare skin continuous contact maximum (45 degrees C, 113 degrees C.)
 - no normal contact for surface 46-49 degrees C. (114-120 degrees F.)
 - must be touched hot surface - provide insulation if greater than 49 degrees C. (120 degrees F.)
 - must not be touched hot surface - provide guard or insulation when temperature greater than 60 degrees C. (140 degrees F)

E. Fire Hazards

Design considerations for man/system interface:

fire hazard - pressurized cabin atmosphere where oxygen content 30% or greater results in hazardous environment (NASA STD-3000,1989)

special emphasis on material selection with:

high ignition temperature

slow combustion rate

low explosion potential

oxygen mask necessary in shirt sleeve environment

toxic hazards

product of combustion resulting in decrease of oxygen and increase of carbon dioxide

fire extinguishing

materials to minimize ignition, limit spread of fire, are self-extinguishing (see NASA STD 3000 Section 6.6.2)

venting or cabin depressurization (see NASA STD 3000 Section 6.6.2)

detection systems (see NASA STD 3000 Section 6.6.2)

5. Atmosphere control

Atmospheric control in the crew support habitat is just as important, if not more important, than the other areas of the base. Of main concern in this area is the comfort of the crew. Also important though is the functionality of the area.

a. General heating/cooling levels

The effective temperature of the habitat module should be kept in a range that is comfortable to as many inhabitants as possible. This will be in the 70 to 80 degree F range. Personal quarters should each have their own adjustments. Most areas will require the need for not only the addition of heat, but more often the removal of heat. This is due to the accumulation of heat from equipment, body heat, etc. Areas with a great deal of heat generating equipment should provide for extra heat dispersal and ventilation.

b. General humidity levels

The overall humidity level should be in a comfortable range for the crew members. Functional aspects of humidity levels must also be taken into consideration. A low humidity level will make static electricity a problem. A high humidity level could lead to corrosion of metals or other problems with control of materials.

c. General ventilation and air quality control

Proper ventilation should be provided to allow for controlled turnover of old and new air. Since there will be no air infiltration from outside or any natural ventilation, a mechanical ventilation system will be necessary. The rate of turnover should be adjustable to allow for efficiency. A frequent turnover rate will be desired during high activity hours. Ventilation equipment should have the capability to remove odors and airborne particles while recycling the air.

d. Special areas

Some areas may need special considerations. The laundry area, depending on the techniques and equipment used, may require special temperature and humidity requirements (i.e. the removal of excess heat and humidity). The personal hygiene and meal preparation areas will require extra ventilation and proper removal of odors before the air in these areas can be recycled.

6. Wayfinding & Coding for Crew Support

a. Lighting Cues:

Use a change of lighting, lighted direction signs, or colored light strips built into the wall or floor.

b. Labeling & Colors:

Labels should be placed in plain sight and should be written in several languages to accommodate the different crews using the facilities. Colors can also be used to indicate various zones, or controls. Label design, and color codes should be consistent throughout the base to reduce confusion, and possible problems.

c. Necessary Emergency Coding & Lighting:

Emergency lighting should respond automatically and indicate the pathway to the nearest safehaven. Emergency lighting should be bright. Emergency coding & labels should be easily read and should be written in several languages to accommodate the different crews using the facilities.

d. International Labels & Symbols:

Labels should be written in several languages to accommodate the different crews using the facilities. Symbols used should be the international symbols which are basically universal and are easily learned and understood.

For more detailed information see; NASA Standards 3000/Vol.1/REV.A

B. Personal Quarters and Associated Components

A. Personal Quarters

1. Components

The title, "Personal Quarters" will cover the areas assigned to individuals as private and personal spaces. These areas include: sleeping quarters, dressing area, personal storage, and Private recreation and leisure. Depending on the final configuration of the initial base, these components may or may not all be located in one room or area. Due to space limitations, the first lunar base, an assembly facility type base, may require that some of these components be split apart. This will not be as big a factor with the initially shorter missions. The dressing area will probably be shared by everyone. Personal storage will most likely involve one storage area in which each inhabitant will receive a number of drawers. Private recreation will be limited to the area used for sleeping.

As mission durations lengthen and the base grows larger, the need for more personal space will grow. Privacy and personalization will become very important and these associated areas will need to be grouped into one area to become more like our "bedrooms" in our Earth homes.

2. Privacy

Privacy will play an important part in the lunar base. The crew will need a place to go to escape from the rest of the crew to be alone. Privacy will be more important in space than it typically is on Earth due to the confinements of being limited to a small area that you know you cannot leave. Some of the problems are obvious. For an example, sleep is a personal activity requiring a quiet surrounding. Physical seclusion is therefore required. Many of the problems associated with privacy are related to the perceptions of the environment. It is possible to make spaces *seem* more private than they actually are. In this way we may be able to effectively create the feeling of privacy without going to drastic, costly means to do it. Because of the need for visual and audio privacy, a physically separated area will be needed to provide complete isolation from the surrounding area. Methods of altering perception may be used within these and other areas.

Sound transmission:

As important as visual isolation is in privacy, so is audio isolation. Sound transmission into the personal quarters should be kept as low as possible. This is not only required for relaxation and sleep, but to help isolate the person from the others, and increase the feeling of privacy.

Personalization:

Personalization plays a large part in privacy. If a person has a space they can personalize, it will reflect their personality and help emphasize their individuality. Personalizing a space can make it seem larger, or at least make the lack of space less apparent. To aid in this process a crew member should easily be able to hang pictures, and otherwise add personal items to their surroundings. These personal items will need to meet certain safety requirements. An example of this would be a concern for flammability and out gassing of the materials.

a. Color/decor

One way to help in the personalization process is to allow for use of color. The use of color is important to add variation to the environment, especially when you are confined to a smaller area. What will help even more is if the crew member can select the color of their personal quarter. This will help in making them comfortable in their surrounding and in emphasizing their individuality.

b. Thermal/light

Another way to personalize a space is in choice of thermal and lighting levels. If someone sleeps better in a cool room they should have the ability to keep their quarters at a lower temperature. In

the same way, lighting should be adjustable too. A range of 0 to 70 foot candles (f.c.) will be needed to meet the needs of the different tasks occurring in the personal quarters. Sufficient light should be available for tasks requiring higher light levels. This can be aided by the use of task lighting.

3. Ergonomics

Though the area will be small, passage through it should be uncomplicated. Associated components should be located near each other.

4. Atmospheric control

The atmospheric control in the personal quarters should be adjustable to the users needs. Most importantly, the temperature level should be easily set at a comfortable level. Also, small alterations in the humidity level and amount of ventilation should be possible.

B. Sleeping Quarters

The sleeping area will be the main area of the personal quarters. With partial gravity present, sleeping will need to be in the horizontal position. An area of 84 cubic feet should be sufficient for sleep, reading, and other activities that may require use of the sleeping area.

1. Anthropometrics

For ease of entry and exit, the top of the bed should be located at a level approximately 18" off the floor. At this level an average person can sit and have their feet touch the ground. A bed will need to be provided with a surrounding open area of 7' long, 3' wide, and 4' high.

2. Materials

The materials involved in the sleeping area will need some consideration. The area should be free of sharp corners and padding may be desired to avoid injury in use of this area. Sleeping materials such as blankets, sheets, pillows, etc. should be easily removable for cleaning. The mattress should be removable for cleaning or replacement should that be desired.

3. Electronic requirements

Separate lighting should be provided for the sleeping area. A general level of at least 10 f.c. will be needed as well as task lighting of 100 f.c. for reading, etc. A main electronics console should be located within easy reach of the sleeping area. On this console should be controls to all lighting in the room, a communications link with the rest of the base, and an alarm system to warn of fire or pressure loss.

C. Dressing Area

The dressing area is another consideration in the personal quarters. This area will more than likely not be a separate space in its own, but will utilize transition space in the personal quarters. This is much the same as in a bedroom in a home.

Anthropometrics/Ergonomics

The area should allow enough room to stretch out arms and legs to aid in dressing, both in the horizontal plane as well as the vertical plane. An area of 3' by 6' by 7' tall will be the minimum needed space (SICSA, 1989). The dressing area should be located close to the clothing storage area. This will save time and distance traveled while dressing. A place to sit while dressing will also be required. This need could be fulfilled by having the dressing area located close to the bed, which could easily be used as a seat.

D. Personal Storage

The personal storage area is another important area in the personal quarters. It will include the persons clothing, accessories, some toiletry items, memorabilia, and other personal belongings.

1. Coding

The crew members should be able to generally locate what they need just by looking at the storage area. The majority of the coding will be through different sizes and locations of the different storage drawers and closets.

2. Materials

The materials used in the storage area should be durable and easily cleanable. The visible surfaces will be largely flat and should not contain areas that will allow accumulation of dust, dirt, etc.

3. Health/Safety

Storage drawers and doors should not contain sharp corners that could cut or scrape a crew member. Care should be taken in location of these so that they are not in a position where one could bang there head on them.

4. Personalization

Adjustability will be a must in the personal storage area. Closets should allow for variability in the way cloths are hanged or stacked. Drawers should allow for dividers to organize personal items.

5. Anthropometrics

Storage areas should be easily accessible. Heavily used items will need to be in a location that is reachable without much bending or straining. Drawer and closet spaces should offer different sizes that respond to the different items that may be placed in them.

6. Alternate locations

The first base may have much of the personal storage separated from the personal quarters. In this case most of the personal storage for the crew will probably be limited to one storage area. After this crunch for space, in the following bases their will be a definite need to have the personal storage included within the personal quarters. Storage areas could be located both below and above the sleeping area. Space will also be required in the hygiene area for each crew members personal storage.

E. Private recreation and leisure

Private recreation and leisure will be important in a lunar base and must be provided for. Most of this can occur in the personal quarters. It will usually be use of a television, listening to music, or reading a book. Proper lighting should be provided. This will be adjustable up to 70 f.c. to suit the activity, wether this be reading or looking at a monitor.

F. Personal work area

A work area or desk should be provided where the crew member can sit to do personal work. This workstation will include a computer, storage, a movable chair, and access to communications.

C. Personal Hygiene Facilities

Introduction to Personal Hygiene:

These factors must be taken into consideration when designing the personal hygiene facilities:

- a. Psychological Effects- Good grooming can enhance self image, improve morale, and increase productivity of the crew member. Adequate and comfortable bathing and body waste management facilities have been high on the list of priorities if participants in various space missions. Some modification of personal hygiene practices and procedures may be necessary due to equipment design limitations and water supply restrictions. Too great a modification, however, could impact negatively on crew self image and productivity. It would be unwise to expect optimum performance unless optimum conditions are provided.
- b. Odor- objectionable body odors can quickly build without adequate personal hygiene facilities. This is a predictable source of interpersonal conflict.
- c. Ease and comfort of use-experiences with Skylab shower design has shown that personal hygiene facilities will be less frequently used if they are awkward, uncomfortable, or take an inordinate amount of time to use.
- d. Privacy- it is desirable to have privacy for crew members for whole body and partial body cleaning (including donning and doffing of clothing).

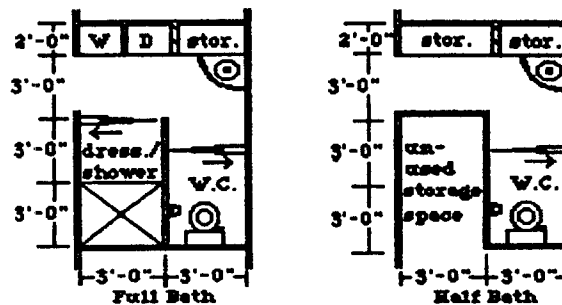

(Moss, 1989)

- e. Feedback- unfamiliar and inadequate facilities and environment can result in crew members falling into patterns of substandard hygiene. The results are likely to be reduced productivity and interpersonal conflict. Provision of full length mirrors or other means of feedback can help to maintain personal image and hygiene habits.
 - f. Mission Duration- shorter missions generally require less extensive personal hygiene facilities.
 - g. Skin Infections- In Skylab, there were skin infections due to microbial buildup and cross contamination between crew members. This must be considered when designing items that will be used by more than one crew member (NASA-STD-3000 /Vol.1 /REV.A / 10.2.2).
- a. Personal hygiene
- 1) Toilet facilities: it is necessary to have privacy for crew members.
 - 2) Shower facilities: need for privacy, or if multiple showers, then grouped by gender, including dressing rooms.
 - 3) Sink and toiletries area: this area is to be the most public, but should have private storage areas for individual's toiletries.

b. Anthropometrics

- 1) Toilet, shower and sink area should be designed with the average adult (male & female) in mind, e.g., adjustable shower heads
- 2) Toilet, shower, and sink areas should be designed with enough room to be comfortable and not feel cramped, and with enough room to change clothes without getting them wet, e.g., separate dressing room

c. Gender issues

Storage area for feminine necessities in toilet area

d Thermal & lighting requirements

- (1) Lighting should come on automatically
- (2) Lighting and temperature should be adjustable

e Health and safety

- (1) Venting should be capable of removing odor and bacteria from air
- (2) Venting should be capable of removing excess humidity from air in shower and laundry area
- (3) Floors in areas where water may accumulate should be non-slip
- (4) All electrical outlets should be ground fault type (type used in areas near water)

f. Atmosphere control

- (1) Lights and temperature should be adjustable
- (2) Venting humidity should be adjustable while area is occupied
- (3) Temperature and humidity controls should respond automatically to increases in temperature and humidity introduced into the habitat

g. Ergonomics

- (1) The toilet, shower, and sink area should be divided into 3 zones connected to each other yet separate, so that all three can be used at the same time by three different people without disturbing one another's privacy

h. Coding

- (1) International symbols should be used in all facilities
- (2) If written instructions are necessary they should be written in several languages, to accommodate different crews
- (3) Individual's lockers should be marked by name or initials

i. Materials

- (1) Materials should be easy maintenance
- (2) Materials should be easily cleaned
- (3) Floors should use non-slip materials in areas where water might accumulate
- (4) Materials should be resistant to rust, mold & mildew

j. Sound transmission

- 1) Noise should be reduced as it enters the hygiene area, e.g., the use of white noise, sound buffers, etc.
- 2) There should be sound buffers preventing excess noise from leaving the Personal Hygiene area, e.g., sound absorbing walls, soft/fabric covered walls, or the use of white noise, etc.
- 3) Toilet and shower area - should have low noise level

k. Personalization

- 1) Individuals should have their own storage lockers for toiletries and towels, but total area should otherwise remain a public area with little or no individual personalization

l. Redundancy

- 1) There should be at least one toilet per four crew member
- 2) There should be one shower for every four crew member
- 3) Definitely more than one sink; personal opinion is 2.5 baths at least for 6-8 people; more half baths for more people
- 4) For 1 - 4 crew members; there should be 1 full bath unit, and 1 half bath unit For 5 - 8 crew members; there should be 2 full bath units, and 1 half bath unit For 9 -12 crew members; there should be 3 full bath units, and 2 half bath units

m. Phasing

- 1) Needed at the beginning of the base in Phase I

n. Proximity

- 1) Hygiene facilities should be located near sleep quarters
- 2) One should also be located near galley
- 3) Cost & Space permitting, another could be located near the exercise area

D. Laundry Facilities

Introduction to Laundry Facility:

These factors must be taken into consideration when designing the laundry facility.

- a. Crew productivity-laundry processing is a potentially significant use of crew time and every effort should be made to reduce the level of crew involvement. The following are means of reducing crew time:
 1. Elimination of the need for pressing laundry.
 2. Elimination of the need to sort laundry prior to washing due to different processing requirements.
 3. Automation of the collection, processing, and distribution functions.
 4. Use of disposable clothing
 5. Location of collection points in areas where the crew will normally change clothing (NASA-STD-3000 / Vol.1/REV.A/ 10.10.2).

1. Privacy

- 1) Laundry: should be kept as a public area
- 2) Group vs. private laundry
 - (a) Private = each individual washes in his or her own laundry (private hampers)
 - (b) Group = laundry done as a job each person is assigned to in rotation (group hampers)
 - (c) Combination of the two = personal hamper and group washing

2 Anthropometrics

Levels of machine openings and controls should be at a comfortable height for average adult (male & female)

3. Thermal & Lighting Requirements

- 1) Lighting should be on command and should be bright enough to easily read directions
- 2) Lighting and temperature should be adjustable

4. Health & Safety

- 1) Venting should be capable of removing excess humidity from air in laundry area
- 2) Floors in areas where water may accumulate should be non-slip
- 3) All electrical outlets should be ground fault type (type used in areas near water)

5. Atmosphere Control

- 1) Lights and temperature should be adjustable
- 2) Temperature and humidity controls should respond automatically to increases in temperature and humidity introduced into the habitat

6. Ergonomics

- 1) Laundry should be placed in a centrally located area, next to the personal hygiene area
- 2) Should be placed out of the flow of traffic

7. Coding

- 1) International symbols should be used
- 2) Instructions should be written in several languages
- 3) Dials and buttons should be colored coded

8. Materials

- 1) Materials should be resistant to rust, mold & mildew
- 2) Materials should be easily cleaned
- 3) Materials should not react with any laundry soaps or cleaners
- 4) Thought should be given to the possibility of using or developing an Ultrasonic cleaner which would cut back on the use of water
- 5) Soaps and/or cleaners must be compatible with the water reclamation system or the laundry must be placed on a separate system to avoid contamination

9. Sound transmission

The laundry should be well insulated to cut down excess sound transmission to other areas of the habitat, e.g., fabric covered walls, sound baffles, etc.

10. Personalization

The laundry should be a public area with little or no individual personalization

11. Redundancy

One laundry facility is necessary for 6-8 people

12. Phasing

To be installed in the first phase of base operation, though during the initial missions of short duration (7+ /- days) it is not absolutely necessary

13. Proximity

- 1) Should be located near sleep quarters and hygiene facilities, also near the galley if hygiene facility is located there
- 2) Some storage should be provide in the area of the laundry for storage of supplies for the laundry and possibly storage of clean towels for use in the galley and bathroom

E. Exercise Facility

1. Equipment, Efficiency

a. Adaptability

The size of the exercise facility is necessarily small and compact. The space must be able to support a broad range of exercise related functions. While "aerobic" classes will not be held in this area, there will be a need for room to stretch the entire body and have clearance for movements associated with exercise along with the required exercise machines themselves. There is a need for the individual machines to provide at least two specialized exercises, either by adding or taking away parts and pieces, or by changing speeds of the machines providing variation in the exercise. In this way, the amount of machines can be reduced by 2 and the layout or spacing will be reduced as well. Also important is the way the facility will evolve over time during subsequent missions or longer missions, as more people use it, or at times when it may be necessary for several people to use the facility at the same time.

While being flexible at first, machines could specialize later as more machines are added. Or the adaptability of the machines could remain while providing more open space for different stretching or exercise programs. As more people use the facility it is necessary to keep their movements and actions in mind as their exercise programs evolve. Controlling how many people will be in a given area within the facility, and how they get from one machine to the next, or how they change the machine to a different exercise will dictate how many people may use the facility at once or how long it will take for a changeover of users.

b. Machines and their variations

There are a few exercise machines that are very flexible in their usage and allow for a broad range of users (sizes, strengths, etc.), and exercises (motions, resistance, forces, etc.). Identified below are some basic machines and how they can be modified for a larger variety of exercises.

1) Stationary Bicycle-provides aerobic exercise and cardiovascular fitness. The bicycle's speed and resistance is adjustable, as well as the height of the seat, etc. Digital readouts of to monitor the exercises are available.

2) Treadmill-provides aerobic exercise and skeletal loading and leg functions. The speed and resistance is adjustable, from a stroll to a run. The incline of the treadmill could be changed for different exercises or to simulate differing terrain during an exercise.

3) Bench Press Machine-provides strength exercises. The machine can be adjusted for several resistance settings and movements. The resisting arm can be adjusted up to provide a military press or down to provide lateral presses. There could be an extension placed on the end of the machine to provide leg extensions. There could be several types of forces: progressive resistance,

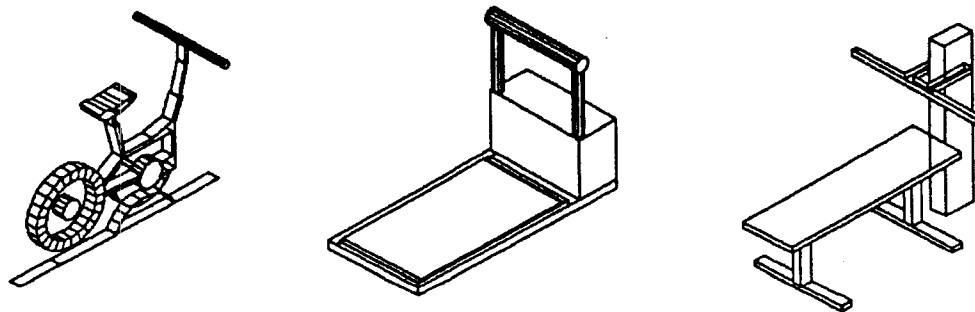

(Chizzo, 1989)

4) Attachable Weights-provide mobile strength exercise that could be on the arm or leg. Several of these could be placed together to create free weights to attach to a bar for more exercises as a set of dumbbells and barbells will not be possible to have. The attachable weights can be used in workstations or while eating or moving about.

5) Rowing Machine-provides strength and cardiovascular exercise. Can be adjusted for speed and resistance. Could be used in rowing motion or changed to create a leg press.

c. Stowage

Since the early facility will be small and probably may not be a dedicated space but rather along a corridor or in conjunction with another space, the exercise machines should be as collapsible as possible. The easiest way to stow the machines is to have them hinge off of the wall and come out of a compartment. Storage of other items could be to disassemble the mechanism and place in a cabinet. This is the most time consuming and clumsy method. Another way is to have the mechanisms come up from the floor, but they might interfere with systems or storage.

d. Computer monitors and their functions

The Exercise Facility should have a basic computer workstation that can monitor human metabolism during workouts and store exercise programs and records. This workstation could be incorporated into the Medical Facility's computer. Every person in the base should be on an exercise program. Goals could be established for each person and it would stimulate productive use of the exercise time. In a weightless environment it is far more important for a daily regimen, but also in 1/6-G the muscles atrophy and bones will reduce in strength and size. Along with the computer being able to monitor and store information, it could calculate how much each person contributes to the base power supply if the bicycle was able to supply power to the station. In this way there would exist some good-natured competition and positive results. Even basic computers are able to monitor several people at once when necessary, and it could also be programmed for individual exercises, for example, if the treadmill were to change inclination every so often in accordance with a visual stimulus on a screen in front of the treadmill.

2. Human Movements

a. Dynamic measurements

The normal body envelope changes with any and every movement. It is possible to allow for every possible movement in the exercise facility; however, the machines will dictate the movements when being used, and the envelope of space needed for each machine will be known and accounted for. Several pages of charts on reach and movements are included in the NASA Standards and should be consulted. Movements in relation to exercise will be comparable to those on Earth with the exception that at first they will be exaggerated because of the still relative strong muscles. The human body gets about 1"-2" taller in space (NASA-STD-3000) but that shouldn't affect movements in adaptable exercise machines. It is important to take into account every possible variation of the exercise machines and apply the 95% male/5% female calculations for the sizing and movement envelopes of the items.

b. Relative strength

Muscles can support 6 times as much weight on the Moon, so if free weights are used they will be 6 times as large and space consuming. It is for these reasons that free weights are very hard to design for and progressive resistance is far better. Again, the hydraulics or resilient material must be able to resist 6 times as much forces.

c. Free space, motion exercises

Along with the necessary exercise machines there should be some kind of open space for stretching or full body movement exercises or tumbling or yoga if that is the case. This space could be used for persons to warm up before exercising on machines, to warm down after a session, or while waiting to use a machine. The space should have some kind of mats or cushioning material on the floor or able to be placed on the floor. The space should also be used for motion exercises such as push-ups or sit-ups, bending exercises, and the shuttle run. Keep in mind that people's tendencies will be to overexert in the early days in space. Above in this space could be a pull-up bar or resistant pull down bar. Dexterity can be enhanced with "toys" or exercise aids; however, these may require more space and perhaps should come later. Physical game development is encouraged as a means to explore capabilities in this new world, much like when we were kids on Earth; however, again, more space may be needed for such a dedicated facility and may come later.

3. Layout

a. Organizing machines

A 2' clear space is recommended between the movement envelopes of each machine (SICSA, 1989). Keep in mind that if this facility is along a corridor, the spacing of the corridor has to be consistent with that needed in an emergency. Care should be taken to keep congestion low in areas of moving equipment. The placement of machines should take advantage of possible overlook into adjacent spaces or into the open area. The organization should facilitate conversation amongst users as a means of socialization while exercising. While it may be necessary in the very early facility, it is bad to have a situation where if one machine were folded out and used it hampers the use of another machine. Another consideration is of noise and vibration control and/or isolation between machines and between the facility and the rest of the base.

b. Special effects

Perhaps the most intriguing possibility for interior architecture is for the special items that can be provided here and in other facilities. Astronauts have previously voiced concern over the lack of windows in a facility (Stuster, 1986), but there are endless possibilities for effects in the lunar base. Incorporated into the stationary bike could be a manual trash compacting machine, or as noted earlier a generator to supply power to the base. There could be a large screen TV to provide sights and sounds (through headphones) of famous bike trails or highways, it could be computer operated to adjust tension on the bike when the screen shows a hill. The treadmill and rowing machine could have much the same effects, moving through famous sites (shopping malls, lakes, etc.),

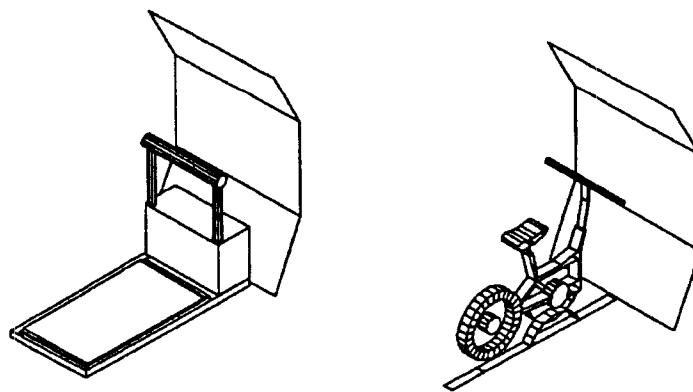

Fig. E.3.b Possible TV Screens

(Chizzo, 1989)

varieties of sights and sounds conforming to the rate of exercising. Audio and visual stimulation can be applied to anywhere in the exercise facility, as well as computer monitoring or control of the exercising session. Even with all these possibilities, a simple window to the outside may be as soothing during a workout as anything else, and if its one of the only ones on the base, then the people have to work out to see outside.

c. Materials, environment

The materials and color in the exercise facility should show dirt well and be easily cleaned. Perspiration and dust generated from movement and the body will be more prevalent here, as will the possibility of spreading germs on the machines as everybody will contact them. Water during the exercise session should be easily obtainable. There need not be any special color in the facility; although, complementing the special effects would be a good idea. Materials should be resilient and abrasion resistant because of all the activity, it is important to protect users from edges and corners. Folding or moving objects should be able to withstand a long life with a minimum of maintenance. Ventilation should be thought of more so in this facility because of the changing demands. A controllable system of fans, ducts and filters could recirculate the air quickly and efficiently in this area several times before reintroducing it to the base's main system. Forced air will be a requirement for cooling, and it should be controllable by the users to adjust to number of people, intensity of exercise, etc. Heating shouldn't be a problem because of equipment generating heat and users generating heat.

4. Phasing

a. Initial objectives

The initial facility will not be a dedicated space, probably located along a corridor. Stowage of machines is essential, as is their flexibility and adaptability. There should be a computer to monitor and store information. The environment should be controllable with respect to ventilation and even visually by closing a curtain. Special effects and open area will be minimal, with space being the major determinant. It would be advised to try to incorporate at least one area that has some outstanding visual quality or effect. It would be possible to incorporate a window in the facility, and keep in mind expansion in the future for placement of machines, the window, and possible open space. The facility will probably be used in shifts so the amount of machines is minimized for now. The volume needed at this phase will be about 672 cu.ft.

b. Longer duration necessities

As mission duration lengthens, the need for a greater variety of stimuli or sufficient variation in the exercise programs to keep the users interested in their respective exercise requirements is necessary. Open space for stretching and perhaps group exercise will be necessary at this point. The

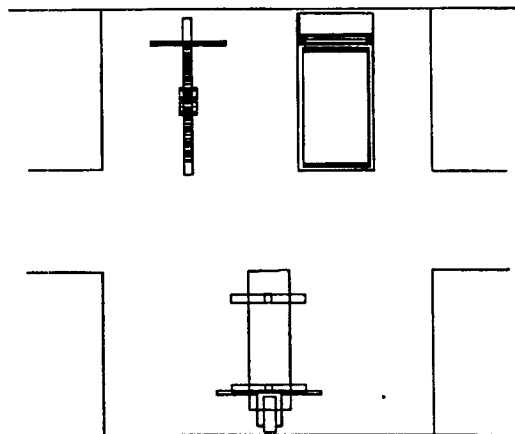

machines should retain their flexibility for different exercises and more emphasis placed on obtaining open space. Special effects and computer programs could be installed now. Overall the amount of machines will stay about the same, perhaps one or two added, while the amount of free movement space will increase. The volume needed at this time would be about 1568 cu.ft..

c. Permanent facilities

In a permanent lunar base, the exercise facility will become its own dedicated facility. In this facility will be specialized exercise machines with audio/visual stimuli, computer monitoring and storage of exercise and health information, and a large open exercise area that can support several types of physical games. The amount of machinery required will be relatively small, perhaps only one or two more machines. The special effects electronics and gadgetry will be installed with the machinery. A gym will be used for games for people to explore the opportunities of 1/6-G to a more full extent. Also necessary at this time will be a shower or cleaning facility in or adjacent to the exercise area. Actually, the large open area may be a storage area for supplies for the base and as the supplies decrease, the open area for recreation will increase. The volume needed at this phase would be about 1568 cu.ft. + the dedicated open space or gym.

Open Space Separate

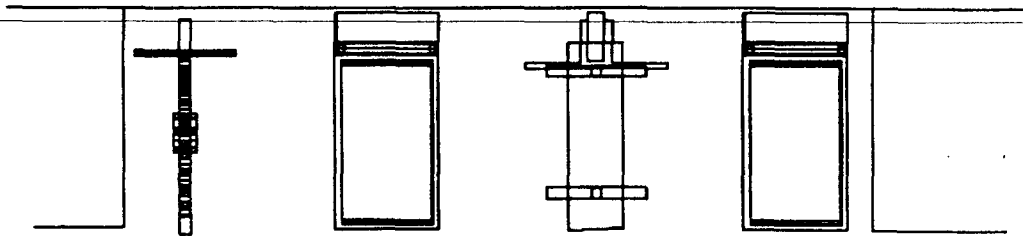

(Chizzo, 1989)

F. Medical Facility

1. Privacy, Safety

a. Movable physical separations

It is imperative that any kind of Medical Facility is able to be separated from everyday movements, traffic, and personnel of the base. The separating device must be a physical barrier and should be a visual barrier as well. The need for a partition is for creating a sanitary environment on demand. During everyday operation of the base, the facility could be accessible to most people as the needs arise. But when an injury occurs or during tests the facility may need to be subdivided or closed off altogether. Inside the facility could be a sink for the medical person(s) to wash before, during or after any actions within the closed off environment.

b. Emergency accessibility

As noted above, the Medical Facility would be accessible during everyday activities at the base. It is important to have portable medical kits to handle small emergencies as well as the capability to handle large emergencies. The Medical Facility should be centrally located for convenience for all who use the base and everything clearly labeled. The base should have one person knowledgeable in administering drugs and routine medical treatments as well as first aid. This person will be responsible for the storage and accessibility of medicine, drugs or other items in the facility.

c. Shielding (visual, x-rays, etc.)

The amount of calamities on the lunar surface equals or exceeds that on Earth. There will be a need for an x-raying machine in the facility and the shielding that goes with it. It is possible to have a bib type of shield like at the dentist but what if the amount of damage to the

body is more extensive? A method for shielding for a larger area is necessary, incorporating it into the partitioning system of the facility is a good idea, or having the patient placed into a self-contained chamber of some sort. With the necessity of possible operations or body inspections comes the obvious need for a visual separation between the facility and the rest of the base and possibly in the facility also. It would also be wise for the computer station to be isolated from damage from physical abuse, X-ray or magnetic damage, thermal or chemical damage, or anything else that might occur in the facility.

2. Environmental Control Materials

a. Thermal and humidity controls

Due to the delicate nature of experiments or operations in the Medical Facility, there should be some way to adjust the thermal and environmental controls. This can be done by specific controls to the storage systems or a way to control the environment as a whole. It may also be possible for a tent or bag apparatus to cover the bed itself.

b. Task lighting

Along with the general base lighting in the facility, the table and work space should be lit with adjustable-intensity, movable task lighting. The lighting should be ventilated or shielded such that it doesn't contribute to the heat in the room. The lighting should be adjustable from controls located in an easy to reach place and be clearly defined. It is also possible to light the storage areas or cabinets on an as needed basis, like the refrigerator would have.

c. Emergency accommodations

The Medical Facility should be equipped with enough supplies to service every member of the facility at one time, from bandages to splints to body bags. As mentioned before, portable medical kits should be readily accessible and able to contain enough items to service more than one person for possible sustained use elsewhere in the base. The controls in the Medical Facility should be easily readable and workable in a possible blackout or smoke environment. The electrical system should have an emergency battery or generator backup for lighting at the floor or specific places in the room and the refrigerator. There should be fire detection and suppression equipment available due to the hazardous nature of the chemicals and oxygen contained in the facility.

d. Sanitation, surfaces

Every surface in the Medical Facility shall be easily cleaned and disinfect. This means that surfaces should be easily accessible and contain no sharp corners or hidden spots to trap dirt. There should be a wash basin in the facility and ample storage for gloves, gowns and towels to keep them sanitary. The movable partitions will provide a sanitary area when needed, but care should be taken to keep the medicine and storage as dirt and germ free as possible.

3. Storage, Coding

a. Large items

Items in this category would be body splints, crutches, portable carrying stretchers or boards, the X-ray equipment, the examination bed in the facility and other bodily sized items. It would seem that the stretchers and such would be used rarely and so should not be the foremost thing in the storage plan. Many of the big items are clumsy and should be placed in a cabinet with a swinging, folding, or rolling door.

b. Medium items

Items here would include the oxygen tanks, the generator for X-rays or emergencies, the refrigerator, electronic analysis systems, and the portable medical equipment and kits. The portable medical kits must be easily locatable and accessible. The other items probably won't leave the facility; therefore, proper labeling to find them during normal use of the facility is

necessary, not for everybody on the base to find them. The medium sized items can easily be contained in average sized cabinets or some of the stationary equipment could slide out on a drawer and used from there.

c. Small items

There are many items that fall under this category. All of the medicine and drugs have to be easily stored and catalogued. The tools and items used during exams and operations should be placed near the operating table and accessory equipment. All of the small splints, bandages and other small utensils must be accounted for. Almost all of these items have to be easily identified and could be in cabinets with transparent doors. It would also be possible to use drawers for some items with a way to secure the contents when not in use.

d. Coding, racks, etc.

The Medical Facility will use perishable items in its operation; therefore, every item must be labeled consistently and catalogued with the computer. Medical records will be stored on the computer, as will the inventory of supplies. This will help in exchanging and adding or taking away the contents of the facility. Removable racks, drawers, or cabinets will expedite the process of changeover and supply management. Each item and the storage systems will need a consistent way to be identified for the medical persons as well as any other user. The identifying system of icons or shapes must be identifiable easily at any time, including emergencies with a possible loss of power.

4. Layout, Phasing

a. Initial objectives

The initial base's Medical Facility will not be a dedicated facility in the sense that it will have to be partitioned off when in use. The layout will hinge on organizing the large amount of storage requirements. The examination table can be collapsible or movable, and the equipment can swing out on arms over or as part of the table. Every user should be familiar to the facility to find material when necessary. The space allotment at this phase should be about 640 cu.ft. including the partitionable area.

b. Longer duration necessities

As missions lengthen, the facility will take on more storage capabilities. Removable racks and new storage areas and supplies must be integrated into the existing system efficiently. Large items

Medical Facility
1st Phase

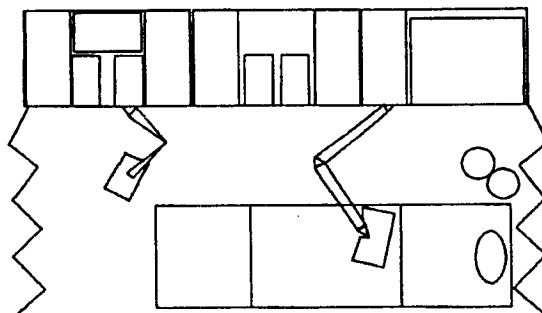

Medical Facility
3rd Phase

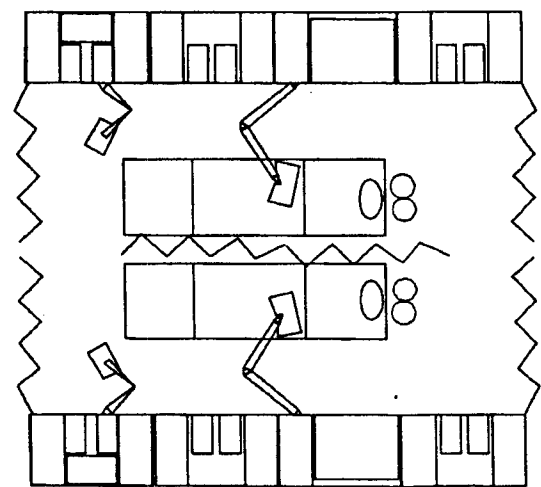

(splints, electronics, etc.) will not increase as much as the smaller supplies and perishables. The types of examinations or necessities for the users will not change. The space needed at this phase will be about 768 cu.ft..

c. Permanent facilities

A permanent facility should incorporate some sort of permanent shielding and/or partitioning. This facility and the Exercise Facility could be easily incorporated into a dedicated facility. The necessity for the Medical Facility to be a dedicated facility in itself is less than the Exercise area, as it is not used everyday. As a permanent facility, the facility will have the same items as before but with much more storage and a larger refrigerator and oxygen storage. The computer may become more powerful to handle the larger storage and the electronic equipment's output. The overall space needed will depend on the amount of new storage more so than open space or other requirements. The volume needed at this phase would be about 1550 cu.ft.

G. Group Recreation Areas

Maintaining two distinctive recreation areas within about 2240 cubic feet of the public realm depends greatly on the architectural elements implemented. The private recreation area is actually going to be within the group area, so considerate design is of essence. Privacy, anthropometrics, personalization and atmosphere are the main considerations when planning for the private area. Anthropometrics, coding, atmosphere, materials and social interaction are the main topics for the group area. Although both areas may occupy the same portion of the base each must be considered independently.

1. Private Recreation Within the Public Area

In order to achieve privacy in a public space, elements which transform a crew member physically and psychologically into into a more solitary setting will be needed.

A. The following are some physical factors recommended to create a personal area within a larger public space

Walls which can be easily stored, for example in the ceiling. Canvas could be used as a wall partition, since it can be easily manipulated.

Each wall may be rendered to an individual's personal taste.

Seating shall be adjustable, meaning reclining and revolving, in accordance with the crew members desire.

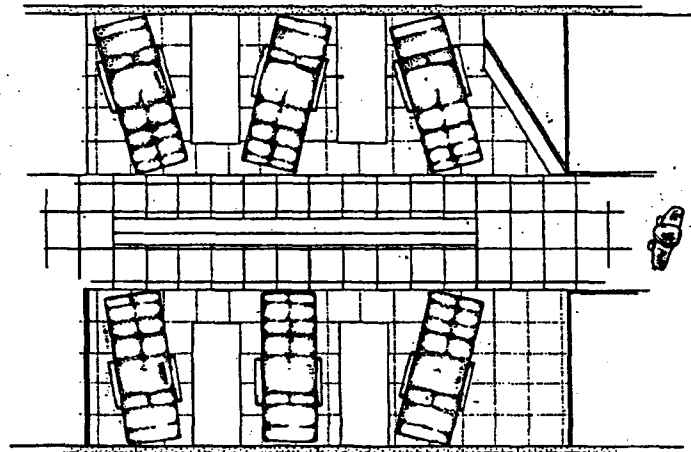

Storage for the crew member's personal items should be available in compartments above the seating or in pockets located in the seat itself.

Personal stereo headphones can transport the astronaut to his or her own world. these should also be stored in close proximity to the seating.

Small personal computers or terminals (possibly situated above the seating) could be used for T.V. transmissions, conversations with family members or games.

B. Anthropometrics

Furniture should comply to the human form in 1/6 gravity conditions. For example, an ordinary 1 gravity posture chair will not be as comfortable as a chair with a slightly exaggerated form.

Equipment should be within the reach of the astronaut while they are seated or standing. While a crew member is working on a particular task or piece of equipment there should be room for other activities to occur.

See NASA Man-Systems Standards 3000 for more details.

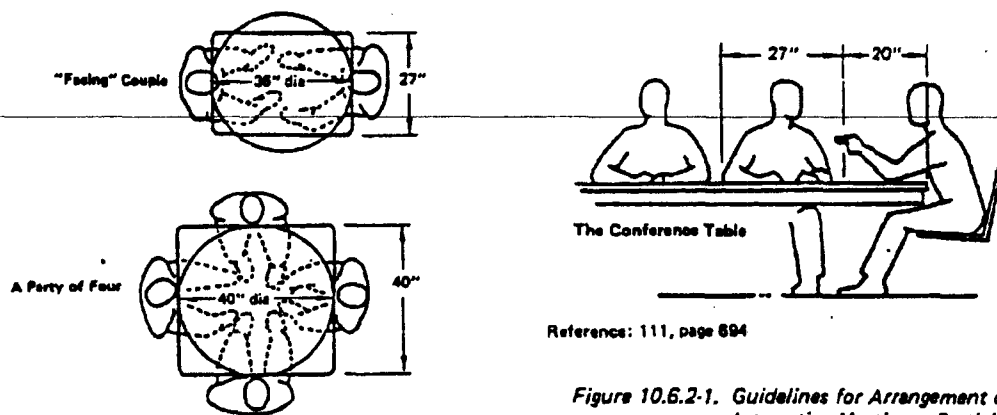

Figure 10.6.2-1. Guidelines for Arrangement of Interactive Meetings: Partial or One Gravity Conditions

C. Color and Decor

Simplicity is needed. Too many colors, complicated schemes, large areas of saturated color and too many fabric variations become annoying especially over long periods of time. Different areas should be decorated and treated differently.

Try to limit visually confusing patterns such as checkerboard or plaid wall coverings.

To prevent large areas of saturated colors, use tone, not just pure colors.

Extreme simplicity can also be detrimental. Drab, singular colors or neutral color schemes and non-textured surfaces are monotonous and could lead to boredom.

D. Atmosphere

The recreation areas atmosphere will be computer controlled but should still allow for some personal adjustment by the crew member. This ability will allow the individual to feel more in control of their environment.

Individual lighting will be provided for each chair and all equipment surrounding it.

The ability to turn this lighting on and off will further add to a sense of personal environmental control.

2. Group recreation Within the Area

In order to achieve a workable group recreation area, some important factors need to be considered

A. Anthropometrics

General anthropometrics for the group area mainly deal with their proximity to each other. Each piece of furniture should be designed to fit both the largest male and smallest female crew member.

The design of instrumentation should also take into account crew sizes as well as nationality differences. Color coding is an excellent method to overcome these possible language barrier differences.

Refer to NASA man-Systems Standards 3000 for more details.

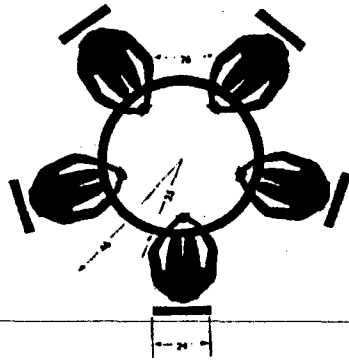

Conference space
measurements

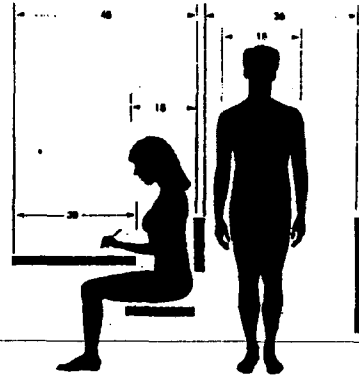

Average corridor/
clearance measurements

(Interiors Magazine,ND)

B. Lighting

Lighting will portray a relaxed atmosphere. arrangement of lighting and task lights will allow a larger space to be interpreted as smaller more private areas.

Coffered panels or recessed lighting should be used because they diffuse illumination and produce a skylight effect possibly reducing glare on CRT screens.

Varying lighting system will also add architectural interest to the space.

The general temperature range should be between 68 and 76 * F.

C. Material considerations

Surfaces should allow for easy cleaning, meaning, they are smooth, protected, or do not contain any areas not easily accessible;e for cleaning.

These surface must also be durable and easily maintained owing to the long duration use of the lunar base.

They must be resistant to abrasion,scratching and corrosive contaminates

For variety, certain surfaces should also be able to be changed with minimal effort.

D. Social interaction issues

Social interaction is a very important use of the group recreation area since it will be one of the only areas in the base where the crew can interact in a less formal way

The furniture should allow for mobility and rearrangement.

The location and relative distances of the furniture should allow for ease in communication.

The space should be large enough for its use by up to 7 astronauts.

All recreation equipment (ie. games reading materials) must also be stored in this area.

Phasing should allow for the eventual separation of the private recreation areas from the public interaction areas as the base grows in size.

H. Meals / Meal Preparation

A. Anthropometrics

U.S. male and female measurements for standing, sitting and reaching are charted below. Additionally, standard height and width measures for structures, workstations, and conference tables will be applied to the habitation module galley configuration.

Galley/meal preparation hardware shall be usable by international crews and by full-range size of crew members.

Refer to general anthropometrics for charts.

B. Coding

Coding for locations of the following shall be simple and concise, giving consideration to the fact that future crews may be international:

1. Food, water, beverage
2. Food preparation materials
3. Utensils
4. Servicing equipment
5. Maintenance and cleaning equipment
6. Wet and dry trash/waste storage

simple, inscribed placards should be applied to compartment facing surfaces using symbols and / or color-coding

7. Coding characteristics
 - a. Ease of use
 - b. Module consistency
 - c. User consistency
 - d. Flexibility
8. Directional designation requirements
 - a. Forward/aft
 - b. Port/starboard
 - c. Up/down

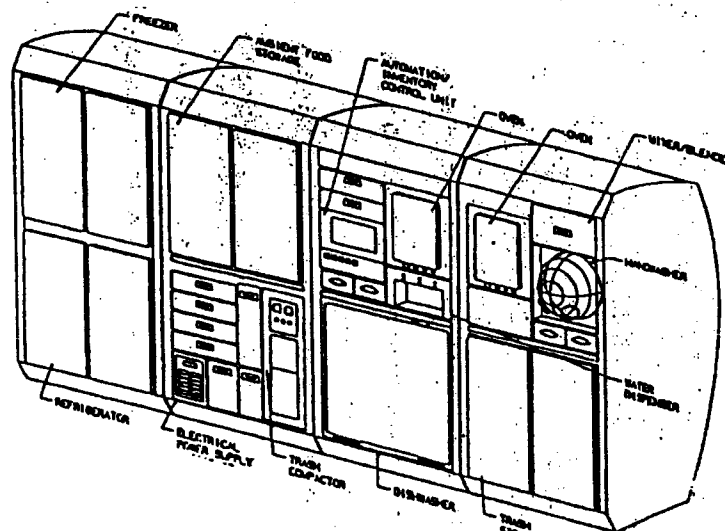
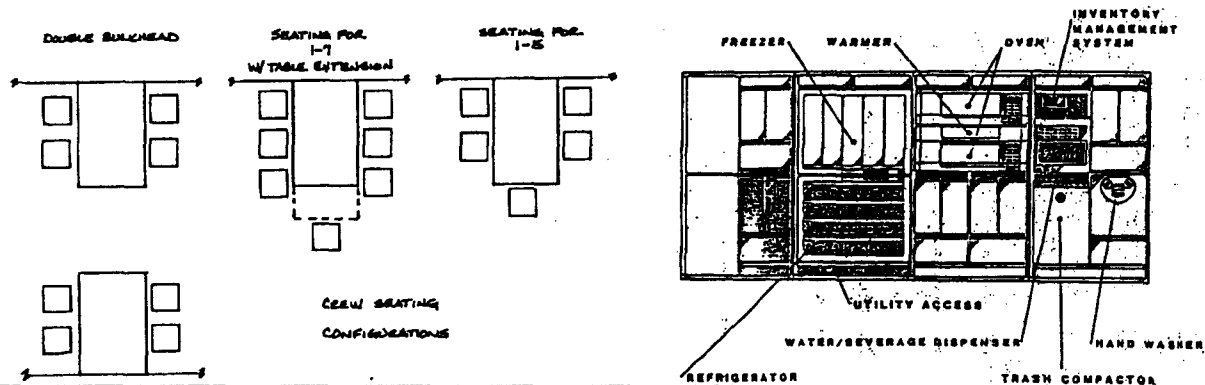

Figure 8.2.1 Galley Layout (NASA-JSC Crew Systems Review, 1988)

C. Lighting

1. General module lighting will continue throughout galley area
2. Specific directional lighting should be placed over dining table
3. Specific task lighting should be placed over food preparation area
4. Lighting should be controlled independently and have dimming capability
5. Lighting controls shall be placed at the entrance and exit of area

(SICSA, 1989)



D. Health and Safety

Food is an important habitability consideration in many confinement situations. (Workshop on CELSS, Mason & Carden 1979) stated food-related research needs: storage stability of food, analysis of feeding systems, nutritional requirements in space, and development of criteria for evaluating health status in response to diet.

1. Proper packaging and storage of fresh and bulk supplies
2. Preservation by freezing and refrigeration
3. Inventory monitoring system
 - a. packing, scheduling, dispensing
 - b. water supply containment and accessibility
 - c. preparation by proper system compatible with specific food type

Crew:

personal nutritional requirements/limitations
 physical safety (see general safety section)
 intake level monitoring system

Utensils:

decontamination
 cleaning
 routine care and maintenance
 disposal of expendable type

Equipment Safety

(see general safety requirements)

Fire prevention, detection and containment

portable fire extinguishers shall be provided for in open areas with backup in food preparation area (see general safety requirements)

E. Social Interaction

1. Stokols (1976) identifies three theoretical perspectives on crowding: stimulus over load, behavioral constraint, and ecological formulation. Stimulus overload relates perceptions of crowding to excessive levels of stimulation that frequently accompany high density. Behavioral constraint focuses on the stresses which follow from restrictions on freedom. Ecological formulations emphasize the shortages of resources which often accompany high density living.

2. Bluth (1982) suggests that space travelers should plan to share at least one meal a day together in order to help dissipate tendencies toward derisiveness that might develop.
3. Meals can do a lot to enhance quality of crew member's lives:
 - satiating hunger
 - chance to rest, socialize, group recreation
 - provide familiar contact to Earth living
 - boost individual morale
 - communal food preparation

F. Atmospheric Control

In addition to general control, specific consideration is demanded in

1. Ventilation of cooking odors
2. Ventilation/control of trash odors
3. Stored food inventory (i.e. refrigeration)
4. Humidity
 - removal of excessive humidity associated with cooking process or dish washing
 - ventilation ducts located near microwave
 - ventilation ducts located near trash receptacle

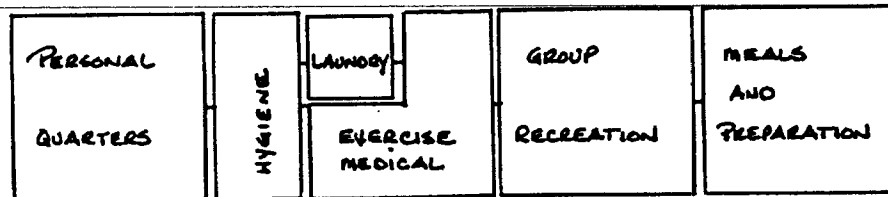

G. Material

1. Must be designed for minimal housekeeping
2. Surface materials
 - Surface materials minimize cleaning and contamination by particles or microbes
3. Free of narrow openings, cracks, crevices
4. Dull surfaces

H. Productivity

1. Galley
 - Design of galley should minimize crew time and effort and maximize acceptability of food
2. Eliminate or automate routine, onerous tasks
3. Method of preparation /cleanup must be considered
 - individual preparation requires larger galley for several crew working simultaneously
 - assigning of one or two crew members to prepare and cleanup may result in smaller galley.
4. Design to aid in the ease of:
 - inventory update and review
 - identification
 - accessibility
 - heating food
 - chilling food
 - hydration
 - service and preparation utensils
 - table use

I. Phasing

1. Initial outpost bare minimum requirements:

- a. food storage for variable crew size
- b. consider amounts for 3-4-5-7 crew size configurations
- c. refrigeration/freezing
- d. microwave/oven
- e. preparation and storage materials
- f. table and seating 3-4-5-7 configurations
- g. consider mission duration 0-3 months

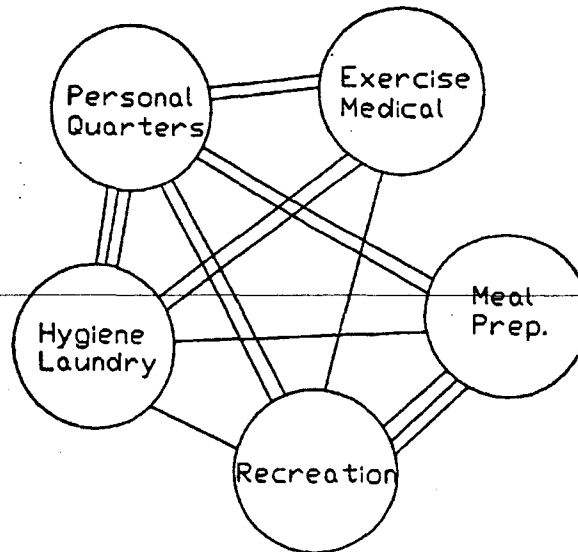

2. Longer duration considerations for 3-6 months
3. Permanent facilities considerations for 6-9 months duration

J. Proximity

Clear traffic pattern configurations should provide for ease of crew performance in :

1. Food selection and inventory
2. Food retrieval
3. Food preparation
4. Food consumption
5. Cleanup

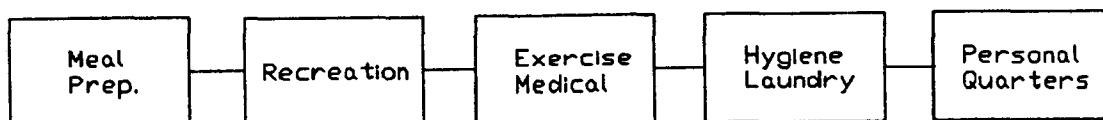

PROXIMITY DIAGRAM, Noisy to Quiet

(Chizzo, 1989)

	A	B	C	D	E
1		FIRST PHASE	SECOND PHASE	THIRD PHASE	
2	PERSONAL	504	504	720	
3	HYGIENE	864	1296	1296	plus 216 per half-bath
4	LAUNDRY	128	128	384	
5	EXERCISE	672	1568	1568	
6	MEDICAL	640	768	1550	
7	RECREATION	2240	2240	2240	plus 200 per person
8	MEAL PREP.	2688	2688	2688	plus 384 per person

(Chizzo,1989)

PHASING CHART, cubic feet

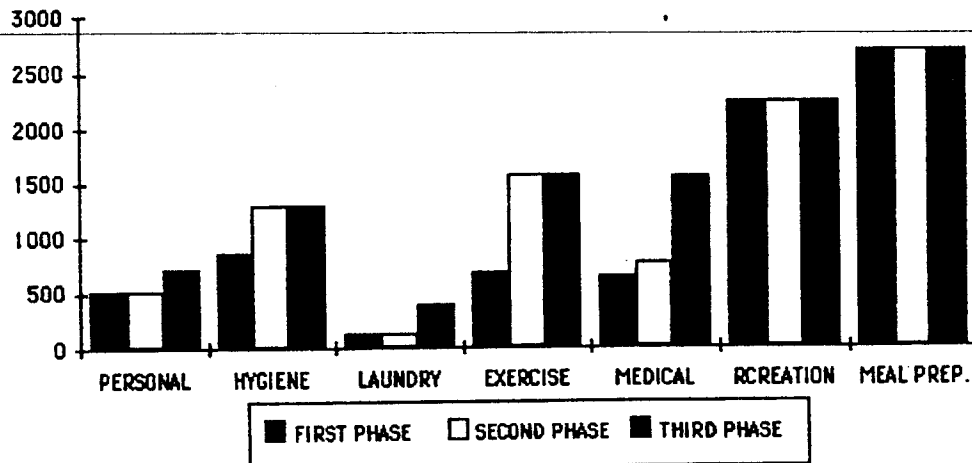

References

- M.M. Connors, A.A. Harrison, E.R. Akins. (1985). Living Aloft: Human Requirements of Extended Space Flight. Washington D.C.: NASA Scientific and Technical Information Branch.
- T.M. Crabb (1989). Introduction to the Lunar Environment and Lunar Environment and Lunar Base Development Issues. Unpublished Manuscript, Orbital Technologies Corp., Madison, Wisconsin.
- Eagle Engineering Incorporated (1988). Conceptual Design of a Lunar Base Solar Power Plant. Houston, Texas: NASA Contract NAS9-17878.
- Interiors Magazine (nd). Human Dimensions, A Pocket Guide for Designers.
- W.W. Mendell (Ed.) (1985). Lunar Bases and Space Activities of the 21st Century, Washington D.C.: Lunar and Planetary Institute.
- MIT (1987). International Space University Campus and Lunar Base Design. Space Habitat Design Workshop, Massachusetts Institute of Technology.
- MIT (1988). Mars Colony Design. Space Habitat Design Workshop, Massachusetts Institute of Technology.
- N. Moore, S. Capps (1989). Lunar Base Construction Shack. NASA / Johnson Space Center Internal Note, Man-Systems Division JSC-23848.
- P.L. Mortazavi, R.M. Bagdigian (1987). Status of the Space Station Water Reclamation and Management Subsystem. Marshall Space Flight Center, S.A.E. Technical Paper Series 871510.
- NASA (1985). Space Station Human Factors Research Review Volume III - Space Station Habitability and Function: Architectural Research, Department of Architecture, University of California, Berkeley.
- NASA (1988). Contract Number NAS 9-17878, EEI Report Number 87-173 LBSS-Maintenance and Supply Options.
- NASA (1989). Man-Systems Integration Standards: NASA STD 3000, Volume I and II.
- T. Polette, L. Toups (1988) Phased Approach to Lunar Based Agriculture in S. Johnson and J. Wetzel, (Eds.), Engineering, Construction and Operations in Space. Proceedings of Space 88 Conference, Albuquerque, NM.
- Sasakawa International Center for Space Architecture (SICSA) (1989). Partial Gravity Habitat Study. NASA / USRA Final Report.
- R. Spangenburg, D. Moser (1988). At Home in the Space Station, Final Frontier Magazine, August.
- Jack Stuster (1986). Space Station Habitability Recommendations Based on a systematic Comparative Analysis of Analogous Conditions. NASA Contractor Report 3943.
- T. C. Taylor, J. S. Spencer, C.J. Rocha (1986). Space Station Architectural Elements and Issues Definition Study. NASA Contractor Report 3941.
- J. A. Wise et al. (1987). Interior Design for the Space Station Habitation Module. Space Design Research Group, University of Washington.