



LabVIEW Controlled Laser Spirograph

Gregory J. McGill

Faculty Advisors: Kim Pierson & Matt Evans

Department of Physics & Astronomy

University of Wisconsin - Eau Claire

Abstract

Mathematical functions can be represented through formulas and visualized with diagrams showing their results for specific input parameters. This is often a static presentation that is hard to interpret. With a laser spirograph, which uses mirrors attached to motors and reflects a laser beam, these functions can be more easily changed and visualized. The spinning mirrors work together to create a rotating pattern which is projected onto a screen. A LabVIEW program allows a user to control the motor speed, where different speeds change the pattern that is produced, similar to changing the input parameters for the function. The created laser patterns can be matched to mathematical models in the form of parametric equations. This work will compare the physical pattern with a computer generated model having the same input parameters to observe differences and similarities between the two methods.

Apparatus

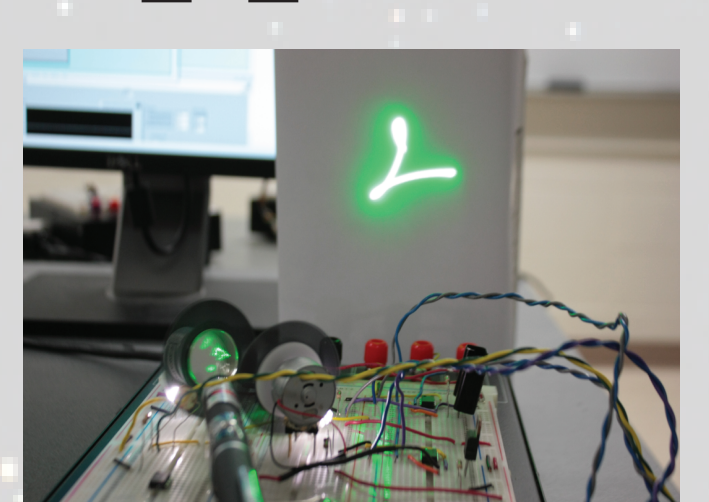
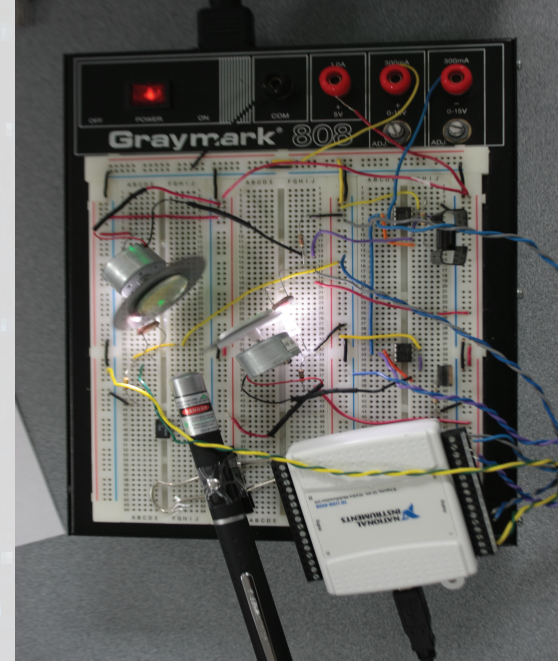
The spirograph is mounted on a breadboard along with the transducer and motor control circuitry. The transducer generates an alternating voltage which the LabVIEW program processes. The program then outputs a signal to the motor control circuit which is used to control the frequency of the motor.

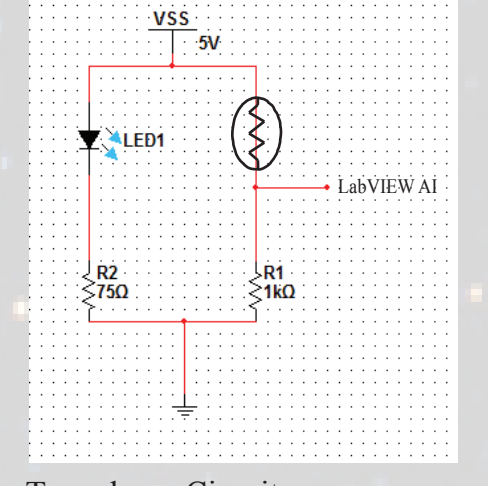
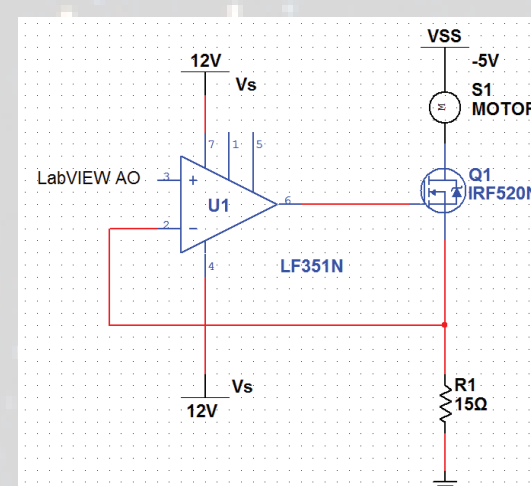
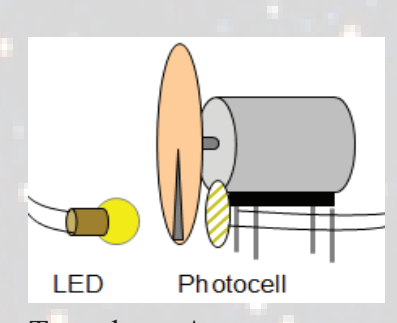
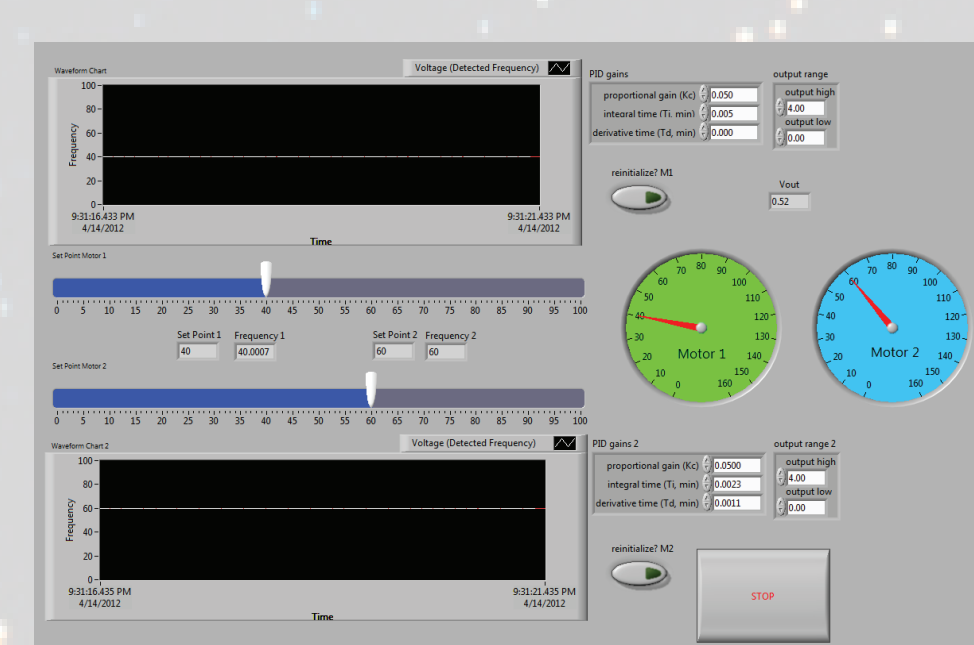
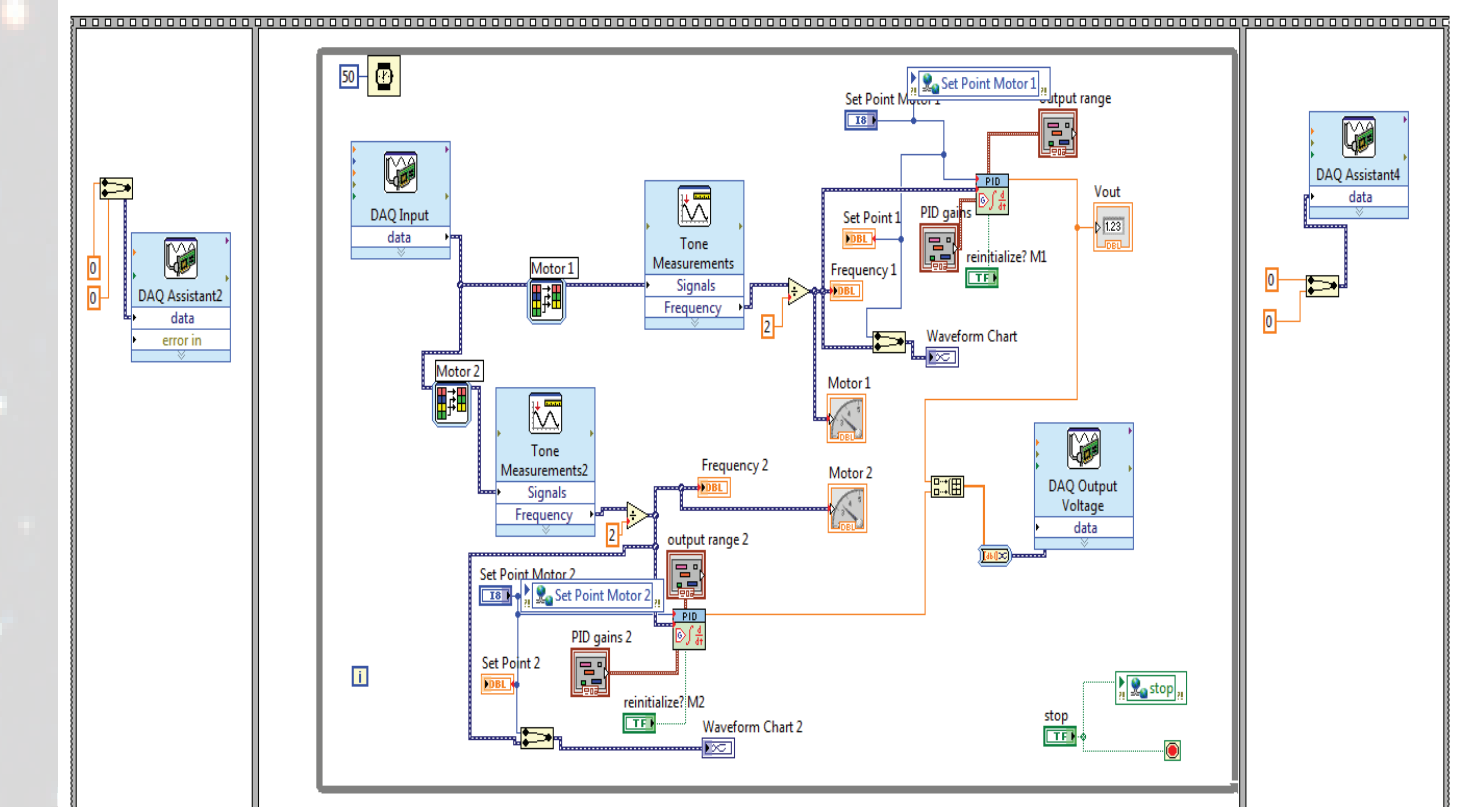



Image Credit: Dr. Kim Pierson, Phys 380 course material

LabVIEW Program



The Dual Motor Controller allows for the adjustment of the frequency of the motors and compares the actual frequency to the setpoint frequency. This program makes use of LabVIEW's built in PID control functions. The PID control automatically adjusts the control signal to the motor control circuit to achieve the most accurate frequency possible. The Simulator uses the set point frequencies to simulate the actual patterns that are produced when the spirograph is running.



The Simulator generates a static image of the pattern produced along with a real time trace.

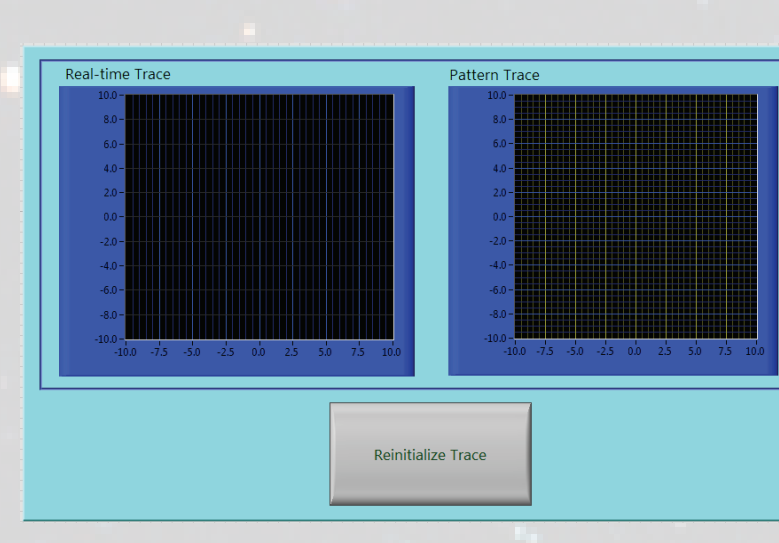
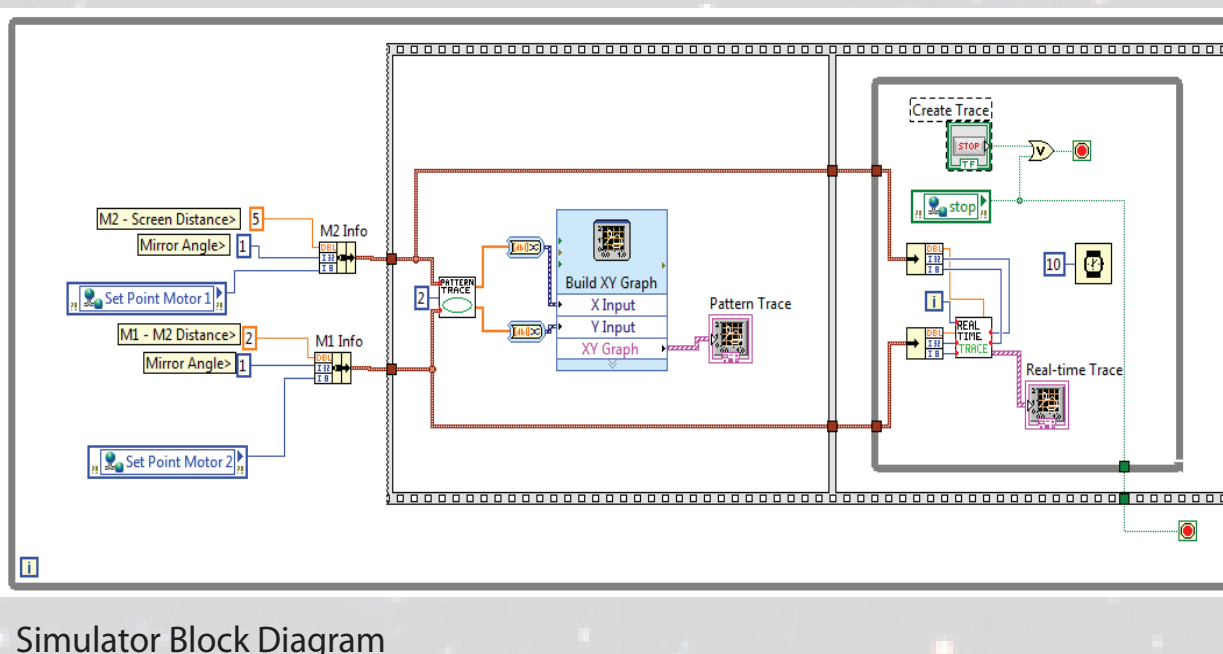



Spirograph Equations

The equations that model the spirograph patterns can be found by transforming the equations for Lissajous figures. These figures are formed with the parametric equations:

$$x(t) = A\cos(at), y(t) = B\sin(bt)$$

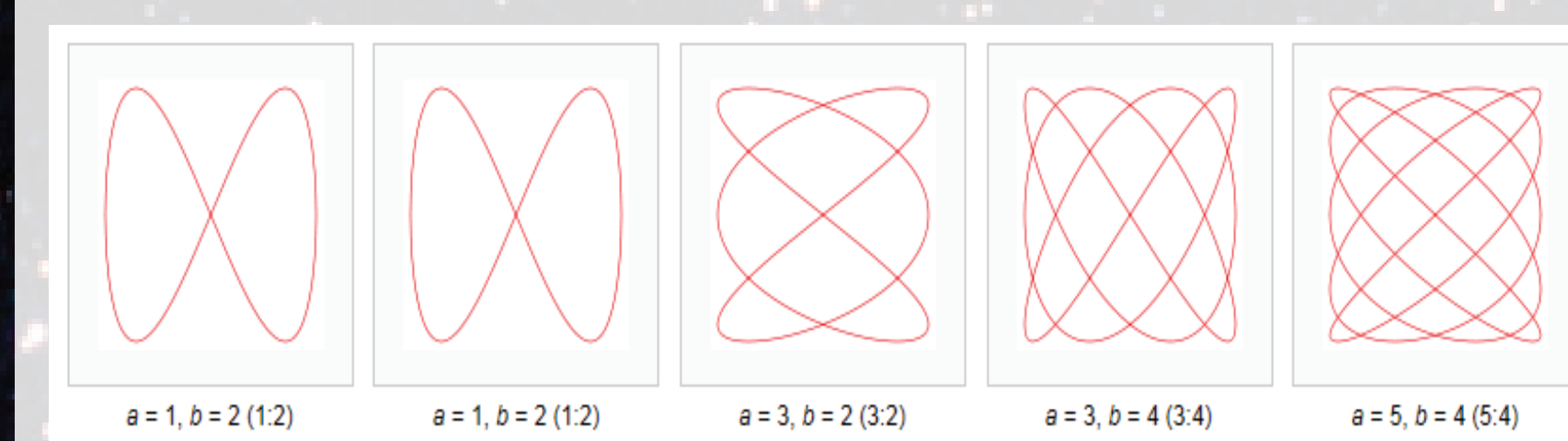
where A, B are amplitudes, while a, b are frequencies. These equations show oscillations in both the x and y direction which vary with different frequencies, as shown below. When the frequencies are the same, a=b, the resulting Lissajous figure is a circle.



Lissajous Figures for different a, b frequency input ratios. Image Credit: Wikipedia, Lissajous Curve

This is the starting point to obtain the parametric equations that represent the spirograph patterns. Adding two individual circles together will yield the spirograph parametric equations:

$$x_1(t) = A\cos(at), y_1(t) = A\sin(at)$$

$$x_2(t) = B\cos(bt), y_2(t) = B\sin(bt)$$

$$X(t) = A\cos(at) + B\cos(bt), Y(t) = A\sin(at) + B\sin(bt)$$

The radii A, B are determined by the distance [d], between both of the motors, the second motor and the screen, and the angle [α], in which the mirrors are mounted on the motor axels. This equation is: $R = d \cdot \tan(\alpha)$.

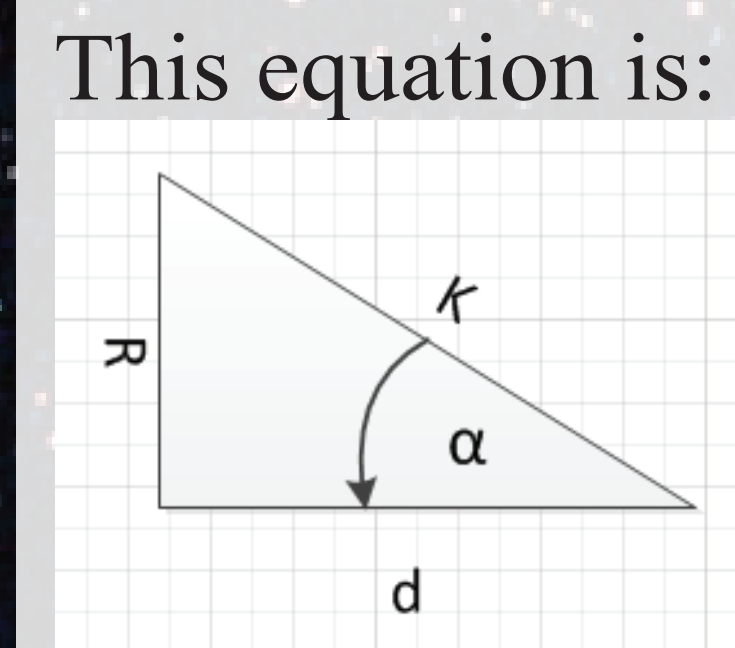

Radius Triangle

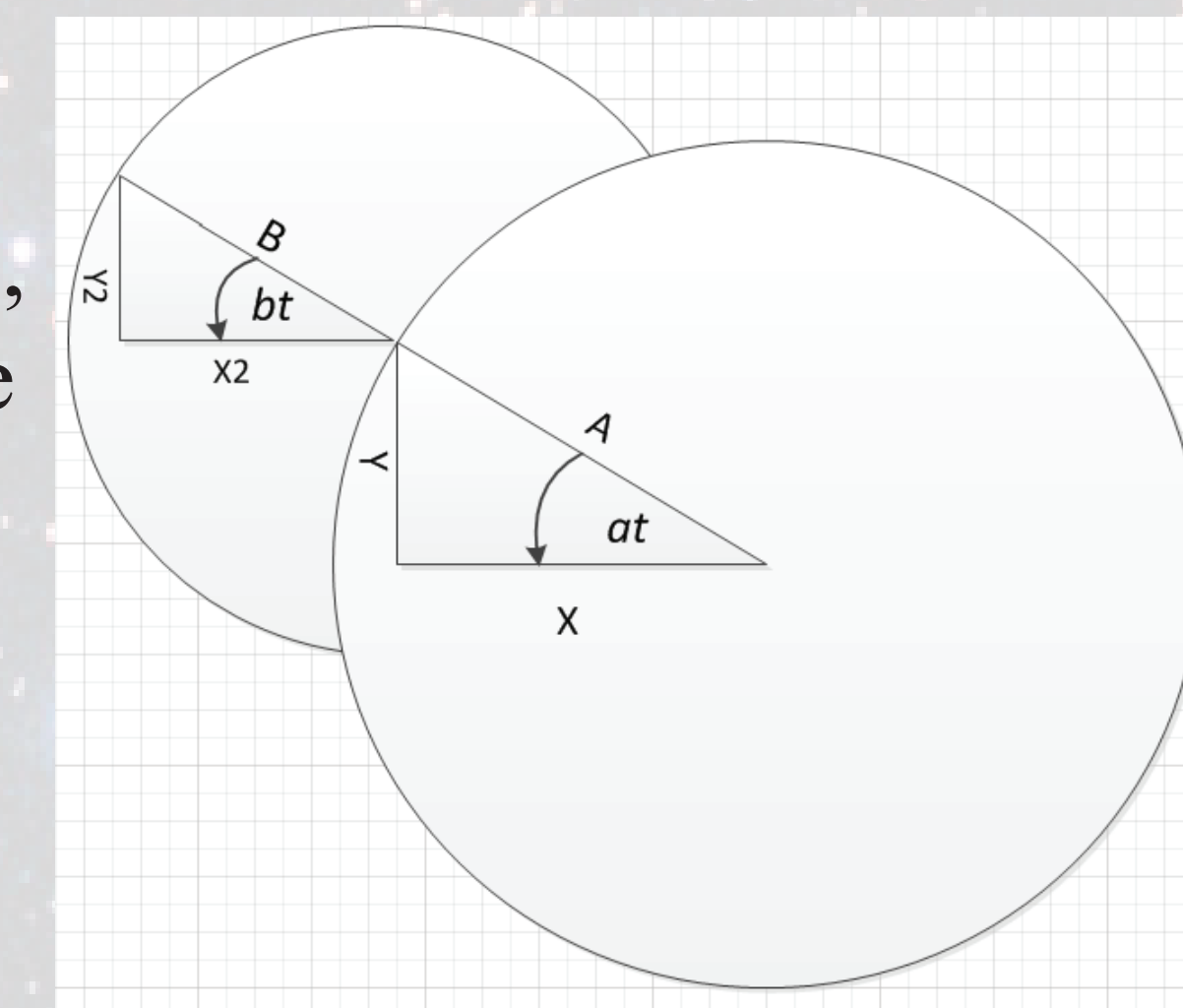

Spirograph Trace Visualization Diagram

By reversing the direction of one of the motors, other patterns can be produced. To model this with the spirograph equations above, a negative sign needs to be introduced to one of the frequency parameters. This reverses the rotation direction of the corresponding motor. Some of these patterns, both with counter-rotating motors and not, can be considered to be standing patterns. That is, certain frequency ratios of a:b result in specific static patterns that do not change or rotate.

Pattern Visualization

How is it that we view the spirograph pattern as a continuous structure, when in reality only a single dot from the laser beam appears on the screen at any given instance? This perception is caused by the natural "refresh rate" of the eye, which is at approximately 30Hz. Because the laser beam is being traced around its respective pattern at such a fast rate, it appears to be continuous. If one of the motors is stopped and the other slowly decreased in frequency, the laser beam dot can eventually be seen tracing out a circle.

The Simulator program shows example of a static pattern with a ratio of 2:3. The laser beam will consistently trace out this exact same pattern.

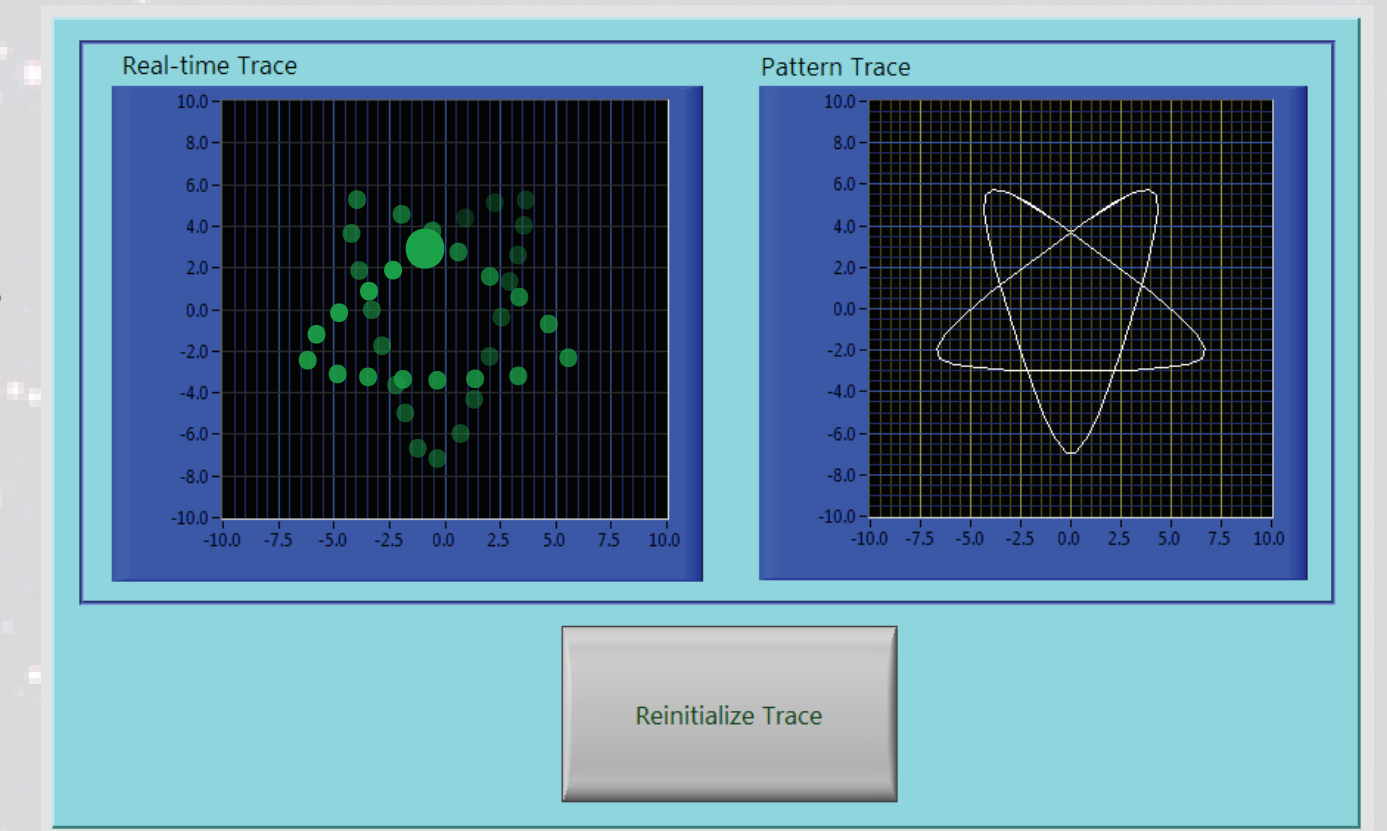

Simulator Front Panel with Spirograph pattern ratio 2:3

The Real-Time Trace image of the Simulator shows how the laser beam retraces this pattern. The large green dot represents where the laser beam would be if the spirograph were frozen in time. The smaller dots become increasingly transparent as we follow the pattern production back through time until the dots overlap the current laser's position indicator dot. If played in slow motion, the laser beam would appear as a bright dot followed by an ever dimming tail. The following images show real patterns produced by the spirograph imaged with different shutter speeds to show the amount of continuity in the 2:3 ratio pattern.



These photographs show a 40:41 ratio and the effect of the phase difference. Imaged at different shutter speeds.

Static Patterns

Acknowledgements

I would like to thank Dr. Pierson for providing me with the necessary knowledge in electronics and LabVIEW programming to complete this project, and Dr. Evans for the guidance and inspiration he has given me. I would also like to thank the Office of Research and Sponsored Programs for funding this project, the Department of Physics and Astronomy Department, and Differential Tuition for the poster printing cost.