

REEXAMINING OBJECT-BASED VISUAL ATTENTION: UNDERSTANDING THE  
NATURE OF DIRECTION-DEPENDENT ATTENTION SHIFTS

by

Adam J. Barnas

A Dissertation Submitted in  
Partial Fulfillment of the  
Requirements for the Degree of

Doctor of Philosophy  
in Psychology

at

The University of Wisconsin-Milwaukee

December 2019

## ABSTRACT

### REEXAMINING OBJECT-BASED VISUAL ATTENTION: UNDERSTANDING THE NATURE OF DIRECTION-DEPENDENT ATTENTION SHIFTS

by

Adam J. Barnas

The University of Wisconsin-Milwaukee, 2019  
Under the Supervision of Professor Adam S. Greenberg

Attentional selection is a process by which relevant sensory stimuli are afforded enhanced priority for processing over and above irrelevant sensory stimuli. Object-based attention is a form of selection that leads to preferential processing of visual information contained in/on an attended object versus an unattended object. Observers typically exhibit enhanced performance to a target at an invalidly cued same object location compared to a different-object location, which results in a same object advantage as measured by the response time (RT) difference between these two target locations. A growing body of research has shown that object-based effects are small, inconsistent, and unreliable. Nevertheless, previous work showed larger same object advantages for horizontally oriented rectangles than vertically oriented rectangles (Pilz, Roggeveen, Creighton, Bennett, & Sekular, 2012). To explain this effect, it was postulated that attention may be more efficiently allocated along the horizontal visual field midline (i.e., meridian) than the vertical midline. Here, our goals are to (1) disentangle the confound between shift direction, object orientation, and object selection/competition and to systematically compare a new metric of object-based attention, the Shift Direction Anisotropy (SDA), to the standard measure of object-based attention, the same object advantage, (2) determine whether the SDA depends upon meridian crossings of object boundaries, target locations, or both, (3) causally implicate the meridians in the emergence of the SDA by examining its susceptibility to

perceptual enhancements of the meridians, and (4) characterize the neural correlates of the SDA. In the end, we demonstrate that the SDA is more larger, consistent, and reliable than the same object advantage, that the SDA is driven by meridian crossings of the invalid target locations, that the SDA is malleable and susceptible to strong perceptual manipulations of the horizontal meridian, and that functional cue-related and target-related neuroimaging data mimic the behavioral SDA. In sum, this work (1) introduces a novel method for investigating anisotropic shifts of object-based attention that have been previously observed in the literature (2) provides the foundation for a comprehensive investigation into the effects of the visual field meridians on real-world object-based attentional selection, and (3) directly challenges and updates current theories of object-based attention to account for visual field and neuroanatomical constraints.

© Copyright by Adam J. Barnas, 2019  
All Rights Reserved

## **DEDICATION**

This dissertation is dedicated to Mom and Dad, Nick and Jill, Grandma Jo and Uncle Jeff, and to the memories of Papa Frank, Grandpa Barney, and Grandma Jane.

## TABLE OF CONTENTS

<b>ABSTRACT</b> .....	<b>ii</b>
<b>LIST OF FIGURES</b> .....	<b>viii</b>
<b>LIST OF TABLES</b> .....	<b>xi</b>
<b>ACKNOWLEDGMENTS</b> .....	<b>xii</b>
<b>CHAPTER 1: Introduction</b> .....	<b>1</b>
Object-based attention .....	1
Effects of object orientation on object-based attention.....	3
Effects of visual field meridians on object-based attention .....	7
Origins of the shift direction anisotropy .....	9
The current experiments .....	12
<b>CHAPTER 2: What Happens When Shift Direction, Object Orientation, and Object Selection Are Disentangled During an Object-Based Task?</b> .....	<b>13</b>
<b>CHAPTER 3: Does the Shift Direction Anisotropy Depend Upon Object Boundaries, Target Locations, or Both?</b> .....	<b>20</b>
Experiment 1: Yoked object boundaries and invalid target locations .....	21
Experiments 2A and 2B: Object boundaries constant; invalid target locations vary .....	33
Experiments 3A and 3B: Invalid target locations constant; object boundaries vary .....	45
Aggregated Analyses .....	53
Experiment 4: Cue-to-target distance control .....	53
Experiment 5: Spatial attention control .....	59
General Discussion .....	64
<b>CHAPTER 4: Is the Shift Direction Anisotropy Susceptible to Manipulations of the Visual Field Meridians?</b> .....	<b>69</b>
Experiment 6: High local feature contrast manipulation with visible lines.....	69
Experiment 7: High local feature contrast manipulation with varying visible lines.....	78
Experiment 8: High local feature contrast manipulation with colored background hemifields.....	92
Experiment 9: Low local feature contrast manipulation with illusory contours.....	98
Experiment 10: Low local feature contrast manipulation with visible meridian ends ....	103
General Discussion .....	107
<b>CHAPTER 5: What Are the Neural Correlates of the Shift Direction Anisotropy?</b> .....	<b>113</b>
Experiment 11: Elucidating the neural correlates of the shift direction anisotropy .....	114
General Discussion .....	147
<b>CHAPTER 6: Conclusion</b> .....	<b>152</b>

<b>REFERENCES.....</b>	<b>158</b>
<b>CURRICULUM VITAE.....</b>	<b>165</b>

## LIST OF FIGURES

Figure 1. Meridian control analysis .....	6
Figure 2. The confound between shift direction, object, orientation, and object selection in the double rectangle cueing paradigm .....	14
Figure 3. A paradigm that permits the measurement of both horizontal and vertical attention shifts within a single cued object .....	15
Figure 4. Initial results of the Shift Direction Anisotropy (SDA) .....	16
Figure 5. Results of within-subjects comparison between the SDA and the same object advantage .....	18
Figure 6. Trial sequence and object-target configurations for Experiments 1-4 .....	24
Figure 7. Mean response latencies in Experiment 1 (Yoked object boundaries and invalid target locations).....	30
Figure 8. Mean response latencies in Experiment 2A (Object boundaries always cross the meridians) .....	38
Figure 9. Mean response latencies in Experiment 2B (Object boundaries never cross the meridians) .....	40
Figure 10. Mean response latencies in Experiment 3A (Invalid target locations always cross the meridians) .....	49
Figure 11. Mean response latencies in Experiment 3B (Invalid target locations never cross the meridians) .....	51
Figure 12. Mean response latencies in Experiment 4 (Cue-to-target distance control).....	57
Figure 13. Trial sequence for Experiment 5 (Spatial attention control) .....	60
Figure 14. Mean response latencies in Experiment 5 .....	62
Figure 15. Shift direction anisotropies across Experiments 1-3B.....	65
Figure 16. Shift direction anisotropies across Experiments 4 and 5.....	67
Figure 17. Trial sequence and meridian manipulations for Experiments 6-10.....	70
Figure 18. Mean response latencies in Experiment 6 (Visible lines) .....	75

Figure 19. Meridian x Shift Direction interaction in Experiment 7 (Variable contrast lines) .....	82
Figure 20. Meridian x Shift Direction interaction for 33% contrast lines in Experiment 7 .....	83
Figure 21. Meridian x Shift Direction interaction for 66% contrast lines in Experiment 7 .....	85
Figure 22. Meridian x Shift Direction interaction for 100% contrast lines in Experiment 7 .....	86
Figure 23. Contrast x Shift Direction interaction for the horizontal meridian in Experiment 7 ....	87
Figure 24. Contrast x Shift Direction interaction for the vertical meridian in Experiment 7 .....	89
Figure 25. SDAs in Experiment 7 and between-experiment comparison with Experiment 6 .....	90
Figure 26. Mean response latencies in Experiment 8 (Colored background hemifields) .....	96
Figure 27. Mean response latencies in Experiment 9 (Illusory contour) .....	101
Figure 28. Mean response latencies in Experiment 10 (Meridian ends) .....	106
Figure 29. Shift direction anisotropies across Experiments 6-10 (Excluding Experiment 7) .....	108
Figure 30. Shift direction RTs affected by meridian enhancements .....	111
Figure 31. Trial sequence for Experiment 11 (fMRI Experiment) .....	116
Figure 32. Mean response latencies across object in fMRI Pilot Study .....	121
Figure 33. Localizers in the fMRI Experiment .....	122
Figure 34. Mean response latencies collapsed across object in fMRI Practice Session .....	125
Figure 35. Mean response latencies across object in fMRI Practice Session .....	126
Figure 36. Mean response latencies for Object x Shift Direction interaction in fMRI Experimental Session .....	128
Figure 37. Mean response latencies collapsed across object in fMRI Experimental Session .....	129
Figure 38. Mean response latencies across object in fMRI Experimental Session .....	130
Figure 39. Cue-related activity for the Region and Target Array interaction .....	132
Figure 40. Cue-related activity for the Cueing and Target Array interaction .....	133

Figure 41. Prioritization of the cued vertex and non-cued vertical and horizontal locations for both non-crossing and crossing target arrays.....	134
Figure 42. Retinotopic cue-related activity for Object, Target Array, and Cueing .....	136
Figure 43. Retinotopic prioritization of the cued vertex and non-cued vertical and horizontal locations for both Objects and Target Arrays.....	137
Figure 44. Cue-related activity in the same retinotopic location .....	138
Figure 45. Cue-related activity in the same retinotopic locations in V1-V3 .....	139
Figure 46. Target-related activity for Region, Object, and Shift Direction interaction.....	141
Figure 47. Attentional orienting at the invalid-horizontal and invalid-vertical target locations as a function of Object and Target Array.....	143
Figure 48. Target-related activity for Shift Direction and Target Array .....	144
Figure 49. Attentional orienting at the invalid-horizontal and invalid-vertical target locations as a function of Target Array .....	145
Figure 50. Retinotopic target-related activity for Object, Target Array, and Shift Direction .....	146
Figure 51. Target-related activity in the same retinotopic location .....	147
Figure 52. Target-related activity at similar retinotopic locations in V1-V3 .....	148

## LIST OF TABLES

Table 1. Object-target configurations for Experiments 1-3B .....	22
Table 2. Mean raw RTs (ms) for correct responses in Experiments 1-3B.....	28
Table 3. Mean error rates (percent misses) in Experiment 1-3B .....	32
Table 4. Mean raw RTs (ms) for correct responses in Experiments 4 and 5 .....	56
Table 5. Mean error rates (percent misses) in Experiment 4 and 5 .....	58
Table 6. Mean raw RTs (ms) for correct responses in Experiments 6-10, by meridian enhancement condition .....	73
Table 7. Mean error rates (percent misses) in Experiments 6-10, by meridian enhancement condition .....	77

## ACKNOWLEDGMENTS

I would like to express my gratitude and appreciation to everyone who, directly or indirectly, supported and assisted me throughout the course of this dissertation work. First, thank you to my advisor and dissertation chair, Dr. Adam Greenberg, for his expertise, assistance, and patience. I am sincerely grateful for the time and effort you invested in me and for helping me grow as a scientist. Second, I would like to thank my dissertation committee, Dr. Deborah Hannula, Dr. Christine Larson, Dr. Wendy Huddleston, and Dr. Edgar DeYoe, for their constructive criticisms, suggestions, and insights. Next, thank you to my lab mates, Dr. Gennadiy Gurariy and Chris Reynolds, and the many research assistants for your feedback and help in conducting this research. I would especially like to thank Dr. Shahd Al-Janabi, Mrinmayi Kulkarni, Lauren Hopkins, Jenna Blujus, Greta Minor, Allison Nickel, and Carissa Weis. You were there for me in countless ways and I will never forget the everlasting bonds of friendship we made in Garland Hall and HOLAF. Lastly, I would like to thank my parents, John and Mary, my brother and sister, Nick and Jill, and the rest of my family and friends, near and far, for their love and encouragement.

Your value to me will grow with age. You all kept me going, and this dissertation would not have been possible without any of you. Thank you.

## **CHAPTER 1: Introduction**

In our modern world, the human brain is bombarded by sensory stimuli of every sort at a rapid rate. Among all the sights, sounds, smells, and tastes that are perceived by our brain, the processing demands of such a large amount of stimulation require a mechanism for the efficient suppression of irrelevant, to-be-filtered information and concurrent enhancement of task-relevant, to-be-attended information. Importantly, this mechanism must also be selective such as not to include other perceptual properties of the surrounding environment. Thus, attentional selection serves as a selective filter through which sensory input flows such that only relevant data are processed at any moment in time, allowing higher order cognitive operations to function on only the most essential and pertinent information.

### **Object-Based Attention**

Because of the known spatial receptive field organization of the visual system (Hubel & Wiesel, 1959), the assumption, for decades, has been that attentional selection is primarily space-based; that is, the information to which one attends is selected based upon its location in the visual field. As a result, directing attention to a specific spatial location allows an individual to more deeply and efficiently process (as measured by speeded responses or heightened accuracy) visual information at this attended location versus unattended locations (Posner, 1980; Posner, Snyder, & Davidson, 1980).

Objects, rather than spatial locations, can also provide a representational basis of attentional selection (Egeth & Yantis, 1997), resulting in preferential processing (and enhanced performance) within the boundaries of an attended object versus an unattended object. Evidence for object-based attentional selection comes from studies employing a variety of experimental paradigms (for reviews, see Cave & Bichot, 1999; Chen, 2012; Moore, Yantis, & Vaughan,

1998; Müller & Kleinschmidt, 2003; Scholl, 2001; Shomstein, 2012), such as tasks involving judgments about object features on spatially overlapping objects, (e.g., Duncan, 1984; Behrmann, Zemel, & Mozer, 1998), multiple object tracking (e.g., Pylyshyn & Storm, 1988; Yantis, 1992), and dissociations in neurological patients (e.g., Egly, Driver, & Rafal, 1994; Egly, Rafal, Driver, & Starrveveld, 1994).

The now-classic study by Egly, Driver, and Rafal (1994) introduced the double rectangle cueing paradigm in which both space-based and object-based attention can be measured simultaneously. They contrasted shifts of attention *within* a pair of rectangles against attention shifts *between* rectangles using a brief exogenous spatial cue (a brightening at one end of a rectangle; 75% valid) followed by a single target appearing in one of three possible object locations: the cued location (“valid”), the far end of the cued rectangle (“invalid-same object”), or the non-cued rectangle (“invalid-different object”). Critically, the two invalid locations were equidistant from the cue. Observers were faster to detect targets at the valid location than either invalid location, a demonstration of a space-based attention effect. Importantly, observers were also faster to detect targets at the invalid-same object location (approximately 34 ms) compared to the invalid-different object location (approximately 47 ms), indicating that attention was not only directed to the cued *location*, but also to the cued *object*, thus producing a small (13 ms) object-based attention effect commonly referred to in the literature as the “same object advantage”. This result cannot be explained solely by a space-based mode of attentional selection, since both invalid-same and invalid-different target locations were equidistant from the cue. Egly, Driver, and Rafal (1994), thus, showed that space-based and object-based attentional selection are not mutually exclusive and operate in an integrated manner.

The same object advantage reflects an increased prioritization of object-based attention to the cued object, and has been observed in a variety of circumstances in which attention is deployed in an object-based manner (e.g., Abrams & Law, 2000; Atchley & Kramer, 2001; Greenberg, Rosen, Cutrone, & Behrmann, 2015; He, Fan, Zhou, & Chen, 2004; Marino & Scholl, 2005; Moore, Yantis, & Vaughan, 1998; Shomstein & Behrmann, 2006; Watson & Kramer, 1999; for a review, see Reppa, Schmidt, & Leek, 2012). Since the original publication of Egly, Driver, and Rafal's research with the double rectangle cueing paradigm, there has been a growing body of evidence demonstrating that the same object advantage is rather inconsistent and/or weak compared to space-based attentional effects. Using the double rectangle cueing paradigm, several studies have exhibited conditions under which they failed to show a same object advantage (e.g., Avrahami, 1999; Law & Abrams, 2002; Shomstein & Behrmann, 2008; Greenberg, 2009), or have even found a reversal of the same object advantage (a "same object cost") characterized by faster RTs at the invalid-different object location than the invalid-same object location (Chen & Huang, 2015; Davis & Holmes, 2005; Harrison & Feldman, 2009; Pilz, Roggeveen, Creighton, Bennett, & Sekular, 2012).

### **Effects of Object Orientation on Object-Based Attention**

An overwhelming majority of the studies reported above utilized the double rectangle cueing paradigm (Egly, Driver, & Rafal, 1994), or a slight variant of that paradigm, to find evidence of object-based attentional selection under a variety of circumstances. However, few studies have considered the orientation of the objects in their analyses: most do not show an effect of object orientation on object-based attentional selection while others do not even explicitly test for effects of object orientation or utilize multiple object orientations. Nevertheless, investigations of object-based attentional selection have begun to consider object

orientation as a potential modulating factor of object-based attentional selection, with several studies finding differential object-based cueing effects for horizontal and vertical objects.

One such study by Pilz, Roggeveen, Creighton, Bennett, and Sekuler (2012) demonstrated that object-based attentional selection varied as a function of object orientation. In this experiment, a large number of observers were presented with the double rectangle cueing paradigm (Egly, Driver, & Rafal, 1994) and performed either a detection task or a discrimination task. Space-based attention effects were observed with both horizontal and vertical rectangles, as evidenced by increased accuracy and faster RTs to a validly cued location as compared to the invalid-same object location. Object-based attention effects, however, were relatively small and inconsistent compared to the space-based effects and varied as a function of rectangle orientation. At the level of individual subjects, only four out of 60 participants exhibited a significant same object advantage while performing the discrimination task with horizontal rectangles. Zero participants exhibited a significant same object advantage with vertical rectangles, but five participants exhibiting a same object cost. Performance was no better in the detection task – with horizontal rectangles, only two participants exhibited a same object advantage and one participant exhibited a same object cost, whereas three participants exhibited a same object advantage and two participants exhibited a same object cost with vertical rectangles.

At the group level, small and inconsistent object-based effects were observed for horizontal and vertical rectangles in both the detection task (12.8 ms and 5.2 ms, respectively) and discrimination task (42.1 ms and -18.89 ms, respectively). Larger same object advantages were observed for horizontally oriented rectangles as compared to vertically oriented rectangles after collapsing across task type. Additionally, a same object cost was observed for vertically

oriented rectangles. Several additional studies have also shown that object orientation can affect the magnitude and direction of object-based selection effects, demonstrating, in general, a same object advantage when the objects are oriented horizontally and a same object cost when the objects are oriented vertically (Al-Janabi & Greenberg, 2016; Conci & Müller, 2009; Harrison & Feldman, 2009; Hein, Blaschke, & Rolke, 2016). In light of these findings, the study by Pilz and colleagues (2012) suggests that (1) object orientation modulates object-based effects when using the double rectangle cueing paradigm and (2) object-based effects are relatively small in magnitude, inconsistent, and unreliable at both the group level and individual subjects level.

To explain this pattern of results, though, Pilz and colleagues (2012) postulated that attention may be more efficiently allocated along the horizontal visual field midline (i.e., meridian) than along the vertical visual field midline. Consider, for example, the case involving horizontal rectangles and a cue that appears in the top left of the visual scene (thus, cueing the upper rectangle). In this scenario, attention to the invalidly cued location of the cued rectangle (“invalid-same location”) is allocated along the horizontal meridian, whereas attention to the invalidly cued location of the non-cued rectangle (“invalid-different location”) is allocated along the vertical meridian. If attention is truly more efficiently allocated along the horizontal meridian as opposed to the vertical meridian, then performance at the invalid-same location would be enhanced (i.e., more accurate, faster, etc.) relative to the invalid-different location (in other words, the same object advantage). On the other hand, for vertical rectangles cued in the same location (thus, cueing the left rectangle), performance at the invalid-different location would be enhanced relative to the invalid-same location (in other words, the same object cost).

Interestingly, work from our lab revealed that these object orientation effects disappear when controlling for shifts of attention across the visual field meridians (Greenberg et al., 2014;

see also Al-Janabi & Greenberg, 2016). Here, instead of comparing the invalid-same object location with the invalid-different object location for a given pair of rectangles, shifts of object-based attentional selection along the vertical meridian (by subtracting RTs to the invalid-same location in the vertical rectangles from RTs to the invalid-different location in the horizontal rectangles) are compared to shifts of object-based attentional selection along the horizontal meridian (by subtracting RTs to the invalid-same location in the horizontal rectangles from RTs to the invalid-different location in the vertical rectangles; See Fig. 1). Controlling for shifts of attention across the meridians revealed no significant differences between the horizontal and vertical meridian, which suggests that effects of the meridians, themselves, may be the cause of the object orientation effects reported by Pilz and colleagues (2012).

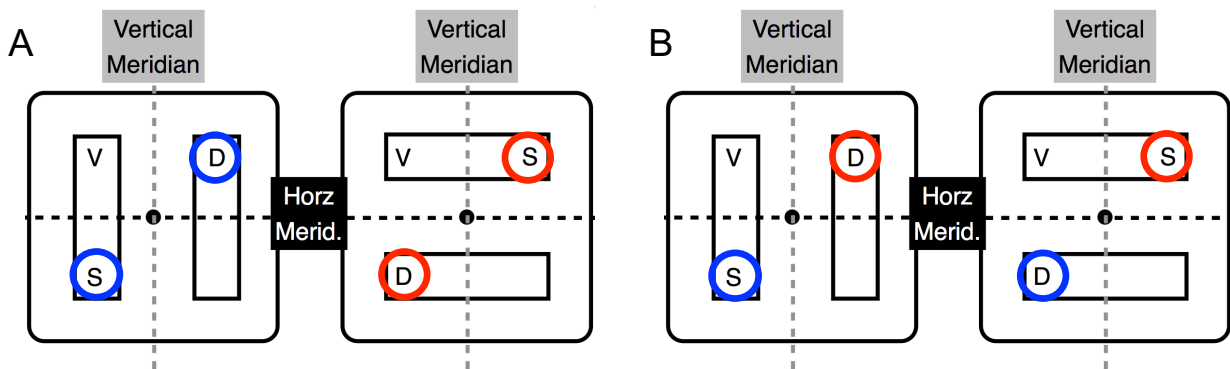

**Figure 1. Meridian control analysis.** (A) The standard way of calculating the same object advantage by subtracting RTs from invalid same object location (“S”) from the invalid different object location (“D”) for vertical rectangles (blue circles) and horizontal rectangles (red circles), separately. (B) The meridian control analysis. For a target appearing in the lower left (blue circles), the analysis is calculated by subtracting RTs to invalid same object locations with vertical rectangles from RTs to invalid different object locations with horizontal rectangles. Conversely, for a target appearing in the upper right (red circles), RTs to invalid same object locations with horizontal rectangles are subtracted from RTs to invalid different object locations with vertical rectangles.

## Effects of Visual Field Meridians on Object-Based Attention

Work from our lab has also systematically investigated the manner by which object-based attention is reallocated across the vertical and horizontal meridians. We were particularly interested in how the reallocation of object-based attention within a cued object, and between cued and non-cued objects, varied as a function of crossing the horizontal and vertical meridians. Rather than utilizing the standard double rectangle cueing paradigm (Egly, Driver, and Rafal, 1994) in which shifts of attention within a cued object are contrasted against shifts of attention between a cued and non-cued object, we modified the paradigm so that both vertical and horizontal attention shifts across the meridians were contained within the boundaries of a single object. This design feature avoided confounding shift direction across the meridians with object selection, as only a single object was ever available for selection. Of interest to this experiment were the differences between response latencies to targets that were presented in invalidly cued locations along the horizontal meridian (“invalid-horizontal”) and vertical meridians (“invalid-vertical”) within a given object (cued or non-cued).

Participants were presented with a single object that consisted of a vertical component rectangle fused with a horizontal component rectangle, which formed a unified ‘L’-shaped object that was centered around a central fixation cross. The object vertex was randomly positioned in one screen quadrant such that one object component rectangle always crossed the vertical meridian and the other object component rectangle always crossed the horizontal meridian. Three trial types were defined by the location of a visual target in relation to a peripheral cue that always appeared around the outer edge of the object’s vertex at: (1) the cued location of the object vertex (“valid location”), (2) the non-cued location of the object’s horizontal component rectangle (“invalid-horizontal location”), or (3) the non-cued location of the object’s vertical

component rectangle (“invalid-vertical location”). Critically, targets on invalid-horizontal trials and invalid-vertical trials were equidistant from the cue.

We found that visual field meridian crossings resulted in a faster reallocation of object-based attention horizontally than vertically (a difference of approximately 79 ms), which we refer to as a horizontal advantage Shift Direction Anisotropy (SDA; Barnas & Greenberg, 2016). This horizontal shift advantage was observed regardless of whether shifts of attention occurred within a single cued object, or between cued (~84 ms) and non-cued objects (~120 ms), suggesting a critical modulatory role of the visual field meridians on the reorienting of object-based attentional selection. Importantly, when using foreshortened objects that did not cross the meridians, no SDA was observed.

These results suggest that the visual field meridians affect the efficiency with which object-based attentional resources are allocated, and also necessitate updating current theories of object-based attentional selection to account for crossings of the visual field meridians. For instance, Shomstein and Yantis (2002, 2004) theorized that object-based attention is guided by an attentional prioritization strategy, whereby higher prioritization is afforded to target locations within an attended object compared to target locations in an unattended object. Attention is prioritized to areas in which the probability of a target appearing is higher (i.e., in the cued object) over locations in which the probability of a target appearing is lower (i.e., in the non-cued object), resulting in the unequal prioritization of attention to the invalid-same and invalid-different locations. This unequal prioritization occurs despite the fact that both locations are equidistant from the cue. Based on this account, object-based attentional resources should be prioritized equally to both invalid target locations (horizontal and vertical) in the ‘L’-shaped object paradigm because we only compare target locations within the same object. However,

attentional prioritization was unequally distributed between these locations whenever attention shifted across the meridians, indicating that observers may also prioritize dimensions of an object that appear horizontally rather than vertically, particularly when objects cross the visual field meridians. Thus, the discovery of the SDA suggests that attentional prioritization may be driven by more than simply target location probability, which is a crucial aspect of this theory.

### **Origins of the Shift Direction Anisotropy**

The visual system neuroanatomy may provide an explanation for the horizontal advantage SDA. For instance, cone photoreceptor density is highest at (and declines at a faster rate from) the fovea along the horizontal meridian as opposed to the vertical meridian (Curcio, Sloan, Kalina, & Hendrickson, 1990; Curcio, Sloan, Packer, Hendrickson, & Kalina, 1987). Primary visual cortex (V1) also contains a larger representation of the horizontal meridian compared to the vertical meridian (Tootell, Switkes, Silverman, & Hamilton, 1988; Van Essen, Newsom, & Maunsell, 1984). Together, these physiological characteristics of the visual system may provide the neuroanatomical means to drive the enhanced processing of visual stimuli that require a shift of attention across the vertical meridian.

Likewise, the anatomical segregations of the visual system provide another possible explanation for the anisotropy between horizontal and vertical shifts of object-based attention, which have been raised previously (Al-Janabi & Greenberg, 2016; Barnas & Greenberg, 2016). Left and right visual field representations are organized contralaterally, imposing an *interhemispheric* boundary along the vertical meridian, anatomically speaking, the longitudinal fissure (Holtzman, Sidtis, Volpe, Wilson, & Gazzaniga, 1982; Reuter-Lorenz & Fendrich, 1992a). As a result, an object that crosses this interhemispheric boundary (i.e., a horizontal object) appears in both the left and right visual hemifields and has a split representation in

corresponding retinotopic areas in visual cortex. Conversely, an object that does not cross the interhemispheric boundary (i.e., a vertical object) appears entirely within the left or right visual hemifield and, thus, is represented fully in the corresponding contralateral hemisphere. In addition, lower and upper visual field representations are also segregated anatomically (Van Essen, 1985; Sereno et al., 1995), forming an *intra*hemispheric boundary along the horizontal meridian (Sereno & Kosslyn, 1991). As a result, an object that crosses this *intra*hemispheric boundary (i.e., a vertical object) appears in both lower and upper visual hemifields, whereas an object that does not cross the *intra*hemispheric boundary (i.e., a horizontal object) appears entirely within the lower or upper visual hemifield.

In consideration of both anatomical configurations, reallocating attention across the interhemispheric boundary, for instance, may prove to be costlier than reallocating attention across the *intra*hemispheric boundary, or vice versa. The split representation across the hemispheres may require significantly more neural resources and processing demands compared to a holistic representation within one hemisphere. Alternatively, some evidence suggests that the contralateral organization of the visual system imparts each cortical hemisphere with its own pool of neural resources (Alvarez & Cavanagh, 2005). Therefore, a split representation would be advantageous compared to a holistic representation. Based on the behavioral results reviewed here thus far, the horizontal advantage that occurs when invalid target locations cross the meridians hints at impaired attentional reallocation across the horizontal meridian and the *intra*hemispheric boundary. Thus, the reorienting of object-based attention to targets within an object is negatively affected when shifting across the horizontal meridian as compared to the vertical meridian. This performance difference may be due to more costly interactions and additional cortical processing incurred from crossing the *intra*hemispheric boundary relative to

the interhemispheric boundary. Indeed, previous studies have shown that the two hemispheres have somewhat independent pools of attentional resources (Alvarez & Cavanagh, 2005); but, under the proper conditions, such as high attentional demands, increased interhemispheric interactions can produce a coordinated unit that functionally expands an individual's attentional capacity, which has been observed for instance, in the auditory domain (Scalf, Banich, & Erikson, 2009). As a consequence, strengthening the interhemispheric interactions across the interhemispheric boundary could likely lead to enhanced performance along the horizontal meridian and support efficient performance during complex visual tasks (Banich, 1998; Banich & Belger, 1990; Scalf, Banich, Kramer, Narechania, & Simon, 2007).

Nominally, both visual system neuroanatomy and the anatomical segregations of the visual cortices, as described above, should affect all forms of attentional selection equally. That is to say, why would mechanisms of object-based attention be more susceptible to the shift anisotropies we have uncovered than spatial attention? We speculate that this is possibly due to the larger physical areas of the visual field that are selected when object-based attention is deployed. Several recent studies using precise visuospatial investigations have revealed elliptical visual field boundaries (Fortenbaugh, Sanghvi, Silver, and Robertson, 2012) and an elliptical shape of the attentional window (Anderson, Cameron, & Levine, 2014; Baldwin, Meese, & Baker, 2012; Pan and Eriksen, 1993) which are consistent with a horizontal attention shift advantage, particularly across the vertical meridian. However, these biases are subtle and may not become apparent unless a single object representation that crosses the vertical meridian is prioritized by attentional mechanisms. Object-based attentional selection causes extended portions of the visual field to be selected simultaneously, a phenomenon that would be unusual during a purely space-based selection. When spatial attention prioritizes a region for enhanced

processing, it is typically limited to the size of a visual cortex neuron's (or group of neurons') receptive field. However, object-based attention typically selects visual field regions that encompass a far larger area. This may be necessary to see the modest directional biases that would cause the SDA.

### **The Current Experiments**

In the following chapters, we attempt to better understand the idiosyncrasies of object-based attentional selection by exploring the visual field constraints and neuroanatomical correlates of the object-based shift direction anisotropy. In Chapter 2, we identify a potential confound between shift direction, object orientation, and object selection that may underlie the variable object-based attention effects consistently reported in the literature. We also uncover a new large and reliable metric of object-based attention, the shift direction anisotropy, and systematically compare it to the traditional measure of object-based attention, the same object advantage. In Chapter 3, we investigate whether the shift direction anisotropy is driven by meridian crossings of object boundaries, target locations, or both. In Chapter 4, we investigate whether the shift direction anisotropy is susceptible to perceptual enhancements of the meridians in order to causally implicate either the horizontal meridian, vertical meridian, or both in the emergence of the effect. Finally, in Chapter 5, we explore the neural correlates of the shift direction anisotropy to understand how the behavioral effect manifests in the brain.

## **CHAPTER 2: What Happens When Shift Direction, Object Orientation, and Object Selection Are Disentangled During an Object-Based Task?**

The same object advantage is the standard for assessing object-based attention effects. It is computed as an RT or accuracy difference between an invalid-same object target location and an invalid-different object target location. A same object advantage is characterized by faster RTs and/or heightened accuracy to the invalid-same object target location above and beyond what is recorded at the invalid-different target location. One of the earliest observations of object-based attentional selection was reported by Egly, Driver, and Rafal (1994) using their infamous double rectangle cuing paradigm. In that seminal article, they reported a same object advantage of just 13 milliseconds (Egly, Driver, & Rafal, 1994). Since then, this single paper has been cited almost 1200 times, and the double rectangle cueing paradigm has been the basis of countless studies on object-based attention.

But, object-based attention has had notoriously mixed findings in the literature. There is mounting evidence demonstrating that object-based attentional effects are smaller and unreliable compared to space-based attentional effects. For instance, Pilz and colleagues (2012) found that object orientation is a contributing factor in the variability of object-based effects. They found larger, albeit small, same object advantages for horizontal rectangles compared to vertical rectangles and concluded that the visual field meridians may be contributing to this difference. Furthermore, a very large sample size ( $N = 60$ ) allowed the Pilz and colleagues to run permutations on individual subject data to examine the prevalence of object-based attentional effects at the level of individual subjects. The results of bootstrap analyses (using an individual's dataset to generate hundreds or thousands of datasets by sampling from the original distribution with replacement) revealed that the small object-based effects (e.g., a 5 ms same object

advantage) were driven by only a handful of participants ( $n = 4$ ). The relatively small size of object-based attentional effects at the group level and the low prevalence of these effects at the individual subject level ultimately encourages questions regarding the reliability and legitimacy of object-based attention as a valid form of attentional selection.

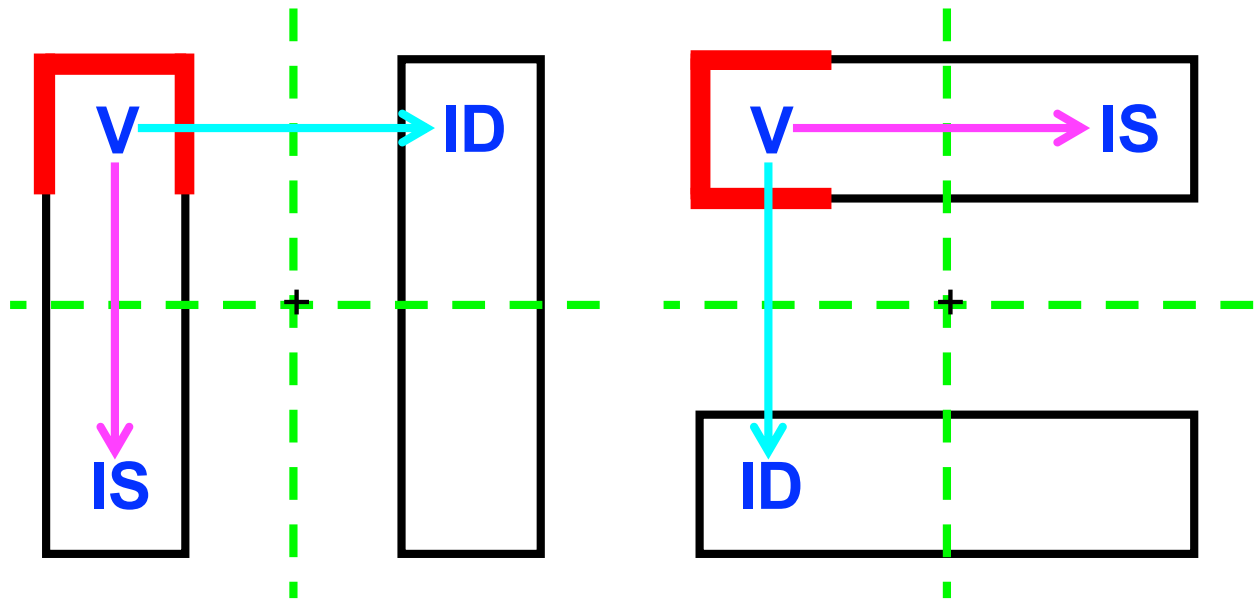

**Figure 2. The confound between shift direction, object, orientation, and object selection in the double rectangle cueing paradigm. (Left)** For vertical rectangles, a horizontal shift occurs from a valid location (“V”) on a cued object (indicated by red outline in the upper left) across the vertical meridian (green dashed line) to an invalid different location (“ID”) on a non-cued object, whereas a vertical shift to an invalid same location (“IS”) occurs within the cued object and crosses the horizontal meridian. **(Right)** For horizontal rectangles, a horizontal shift to an IS location crosses the vertical meridian within the cued object, whereas a vertical shift to an ID location occurs from cued to non-cued object across the horizontal meridian. Both IS and ID and equidistant from V.

There is a largely overlooked confound between shift direction, object orientation, and object selection/competition that may be responsible for these variable and inconsistent object-based effects (See Fig. 2). In the standard double rectangle cueing paradigm with vertical rectangles (one positioned in the left hemifield and the other positioned in the right hemifield), a vertical shift of attention from a cued location to an invalid-same object location (across the

horizontal meridian) is restricted to the boundaries of the cued object, whereas a horizontal shift of attention to the invalid-different object location (across the vertical meridian) must cross object boundaries, from the cued object to the non-cued object. The same occurs for horizontal rectangles (one positioned in the upper hemifield and the other positioned in the lower hemifield). Here, a horizontal shift of attention to the invalid-same object location (across the vertical meridian) is restricted to the boundaries of the cued object, whereas a vertical shift of attention to the invalid-different location must cross object boundaries.

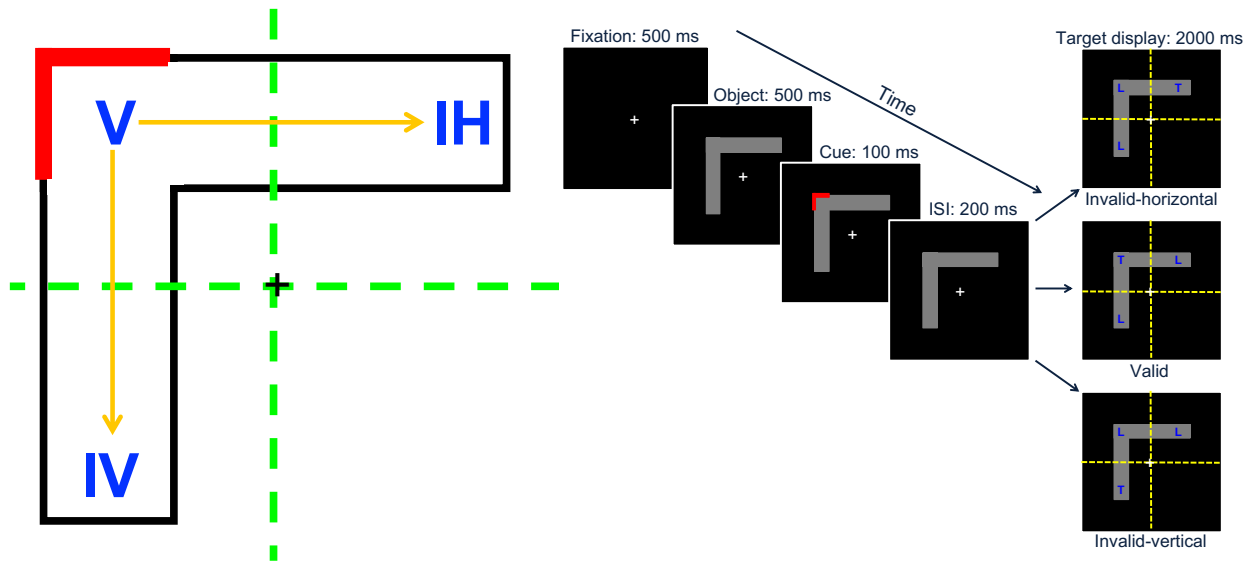

**Figure 3.** A paradigm that permits the measurement of both horizontal and vertical attention shifts within a single cued object. (Left) For this ‘L’-shaped object, a horizontal shift occurs from a valid location (“V”) across the vertical meridian to an invalid horizontal location (“IH”) and a vertical shift occurs from V across the horizontal meridian to an invalid vertical location (“IV”). Both IH and IV are equidistant from V. (Right) Trial structure from Experiment 1 of Barnas and Greenberg (2016).

We developed a paradigm that controlled for this confound (See Fig. 3). The traditional double rectangle cueing paradigm was modified to create an object that permitted both vertical and horizontal shifts of attention across the meridians to be contained within the boundaries of a single object (the ‘L’-shaped object paradigm), thus eliminating the confound of object selection

with shift direction across the meridians. Our main interest was the RT difference between an invalid-vertical location and invalid-horizontal location (both same object locations and equidistant from an exogenous cue). At the group level, we found that RTs to the invalid-horizontal location were significantly faster than RTs to the invalid-vertical location by approximately 78 ms (See Fig. 4), which we refer to as the Shift Direction Anisotropy (SDA; Experiment 1, Barnas & Greenberg, 2016). In a follow-up study, individual subject data were also examined to understand the reliability and prevalence of the SDA. Using a similar method as Pilz and colleagues (2012), individual subject data from our initial observation of the SDA were bootstrapped and used to generate 95% confidence intervals to assess whether a participant exhibited a significant effect. Here, 21 out of 32 participants exhibited a significant SDA (See Fig. 4; Barnas & Greenberg, *OPAM* 2017). Relative to the proportion of total individual participants who exhibited a same object advantage (15%), as reported in Pilz and colleagues, we

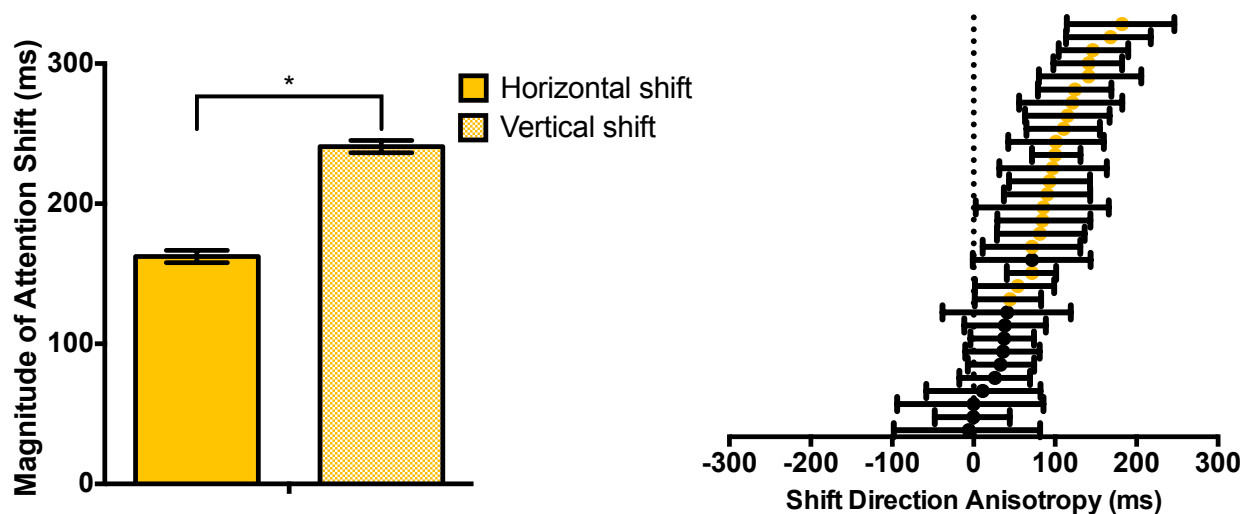
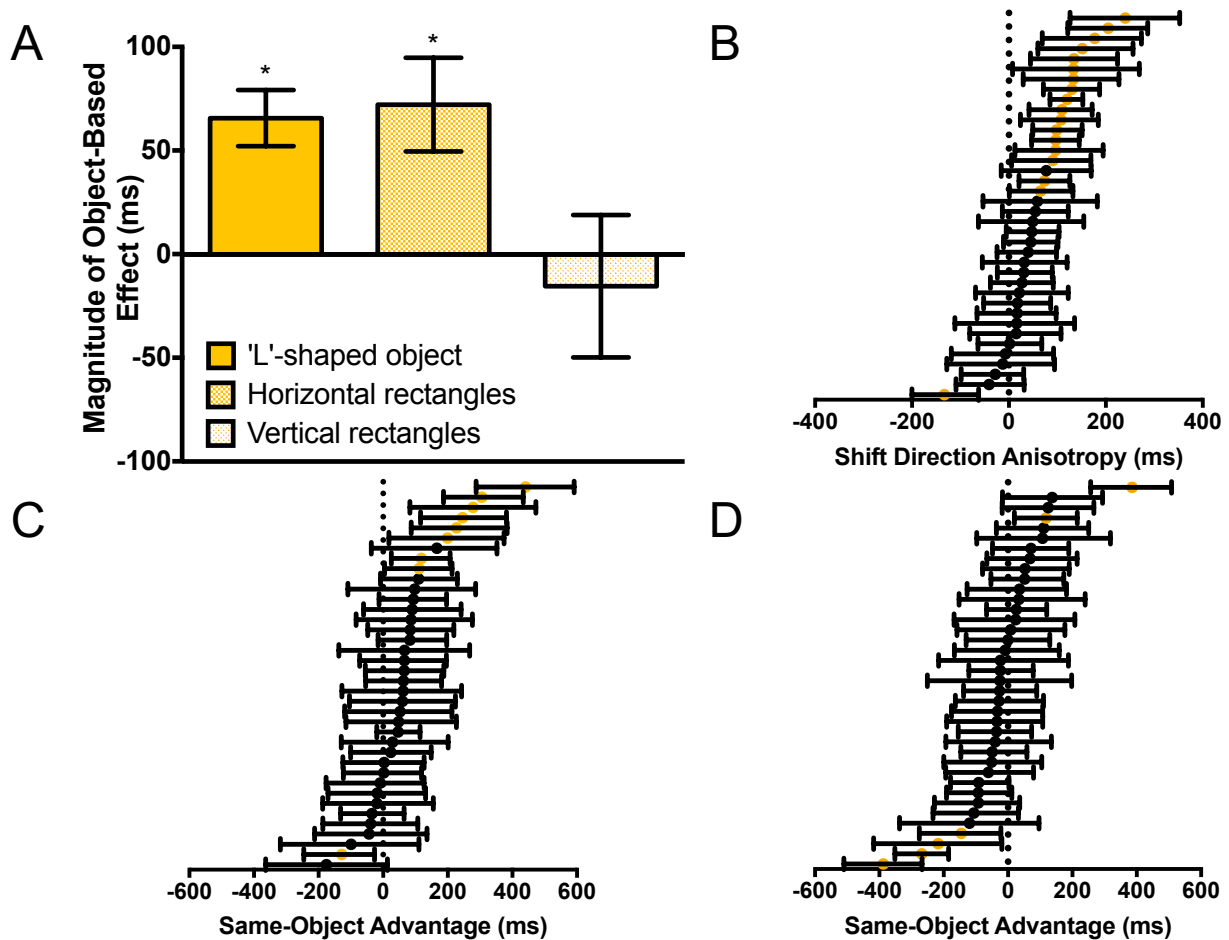

**Figure 4. Initial results of the Shift Direction Anisotropy (SDA).** (Left) Group level results showing a significant RT advantage for horizontal shifts compared to vertical shifts, resulting in the Shift Direction Anisotropy (SDA). (Right) Individual subject data. Data were bootstrapped and used to form a 95% confidence interval. Each dot represents a single subject. Negative values indicate a vertical advantage and positive values indicate a horizontal advantage (the SDA). Significant SDAs are denoted by yellow dots.

found that a statistically larger proportion of participants exhibited a significant SDA (65%),  $\chi^2(1, N = 92) = 24.08, p < 0.001$ . Based on the results of this comparison, the SDA appears to be a larger, more reliable effect than the same object advantage.

In order to better compare the SDA and the same object advantage, a within-subjects experiment was also conducted where participants completed the ‘L’-shaped object paradigm and the standard double rectangle cueing paradigm. In this experiment, 38 participants ( $M_{\text{age}} = 22.15$  years,  $SD_{\text{age}} = 7.95$  years; 18 women, 10 men) completed 4 blocks of each object type (‘L’-shaped object or parallel rectangles). Horizontal rectangles were  $12.0^\circ \times 2.0^\circ$  and vertical rectangles were  $2.0^\circ \times 12.0^\circ$ , including the component rectangles that formed the ‘L’-shaped object. All invalid target locations were equidistant from the cued location. Target locations were conserved such that targets appeared in the same spatial coordinates across blocks. Thus, the only manipulated factor was whether horizontal and vertical shifts of attention occurred within a single cued ‘L’-shaped object or between cued and non-cued rectangles. Participants performed a detection task, responding to the presence of a target letter (‘T’) that appeared on 80% of trials with 60% validity (at the cued location). The remaining 20% of target-present trials were split evenly among the two invalid target locations for each object type (10% for both invalid-same and invalid-different locations, and 10% for both invalid-horizontal and invalid-vertical locations). Non-target letters (‘L’) were used as placeholders in the locations unoccupied by a target letter. A target was absent on 20% of trials, in which non-target letters appeared in all three target locations. The dependent variable was RT, which was used to compute group and individual subject level effects for both the shift direction anisotropy and same object advantage.

As shown in Figure 5, a significant SDA (~66 ms) was observed at the group level, indicating that horizontal shifts of attention were significantly faster than vertical shifts of



**Figure 5. Results of within-subjects comparison between the SDA and the same object advantage.** (A) Group level results. “Magnitude of Object-Based Effect” refers to the SDA for the ‘L’-shaped object or the same object advantage for horizontal and vertical rectangles. (B-D) Individual subject results for the ‘L’-shaped object, horizontal rectangles, and vertical rectangles, respectively. Each dot represents a single subject, bars indicate 95% confidence interval. Positive values indicate an effect in the predicted direction (horizontal advantage SDA or same object advantage). Significant effects are denoted by yellow dots. In general, a larger proportion of individuals exhibited a significant SDA compared to a same object advantage.

attention when contained within the boundaries of a single cued object. Individual subject analyses revealed 17 participants exhibited a significant SDA. A significant same object advantage was observed for horizontal rectangles (~72 ms, quite larger than the size of the effect observed by Pilz et al., 2012) that was reliably observed in only 9 participants. Finally, a similar

result as observed by Pilz and colleagues was found, here, for vertical rectangles – a reversal of the same object advantage (a same object cost). This effect, however, was not significant and emerged in only 4 participants. Mirroring the between-experiment results reported above, a significantly larger proportion of individuals exhibited a shift direction anisotropy (45%) versus a same object advantage for either horizontal or vertical rectangles (17%),  $X^2(1, N = 32) = 5.77$ ,  $p = .016$ .

Overall, these findings demonstrate that the often overlooked confound between shift direction, object orientation, and object selection might have caused past inconsistent and unreliable object-based attentional effects. Additionally, when controlling for these factors, a new effect, the shift direction anisotropy, emerges that is larger and more prevalent than previous reports of the same object advantage, suggesting that the SDA may be a more reliable and sensitive measure of object-based attention than the traditional same object advantage. Thus, stable and large magnitude effects of object-based attentional selection do exist when examined from a perspective that ameliorates significantly confounding factors. In the following chapters, the idiosyncrasies of object-based attention by proxy of the SDA will be further investigated in order to obtain a more accurate understanding of direction-dependent shifts of object-based attentional selection.

## **CHAPTER 3: Does the Shift Direction Anisotropy Depend Upon Object Boundaries, Target Locations, or Both?**

Our previous observations have shown that object placement within the visual field (i.e., whether or not an object crosses a meridian) is an important factor in the efficiency of object-based shifts of attention. However, since target location (relative to the meridians) was confounded with object size/placement in our initial experiment (in other words, targets were always located  $1.0^\circ$  from the near end of the object, and were always coupled with object crossings), it remains an open question as to whether object placement or target location, in relation to the meridians, is the primary driver of the SDA. The answer to this question has significant implications for theories of object-based attention. The attentional prioritization account (Shomstein & Yantis, 2002, 2004) is predicated on targets flexibly guiding the allocation of attention throughout an object as opposed to an automatic spread of attentional resources. The attentional spreading account (Vecera & Farah, 1994; Richard, Lee, & Vecera, 2008) suggests that object boundaries automatically guide the allocation of attention throughout an object. If the SDA is primarily driven by target location, this implies that the attentional selection of an object depends on the information within the object that is behaviorally relevant at that moment (i.e., the target). On the other hand, if the SDA is primarily driven by object size/placement, this implies that object boundaries play a more extensive role in the allocation of attentional priority. Conceptually, these two outcomes map on to support for two of the most well-established theories of object-based attention: the attentional prioritization theory (Shomstein & Yantis, 2002, 2004) would be supported if the SDA is driven by target location; the attentional spreading theory (Vecera & Farah, 1994; Richard, Lee, & Vecera, 2008) would be supported if the SDA is driven by object extent.

Here, our goal is to determine whether the shift direction anisotropy depends upon meridian crossings of object boundaries, target locations, or both. Five experiments are described during which we manipulated both the boundary positions of a single cued object and the target locations across the visual field meridians. We measured RTs to detect a visual stimulus at invalid-vertical and invalid-horizontal target locations and calculated the RT difference to derive the SDA. In Experiment 1, we simultaneously manipulated the position of the object and locations of invalid targets across the meridians, such that both the object boundaries and the locations of invalid targets either crossed or did not cross the meridians. In Experiments 2A and 2B, object placement was held constant while we manipulated the invalid target locations relative to the meridians. The object boundaries always crossed (Experiment 2A) or never crossed (Experiment 2B) the meridians. In Experiments 3A and 3B, invalid target locations were held constant while we manipulated the object placement relative to the meridians. Invalid targets always crossed (Experiment 3A) or never crossed (Experiment 3B) the meridians. Two subsequent control experiments were also conducted. In Experiment 4, we controlled for the systematic variation of the cue-to-target distance in order provide unequivocal evidence for the interpretation of the results. Finally, in Experiment 5, which served as a spatial attention control, the object was removed from the paradigm in order to determine whether object-based or space-based attentional resources were being deployed.

### **Experiment 1: Yoked Object Boundaries and Target Locations**

The goal of Experiment 1 was to test conditions under which the object boundaries and invalid target locations simultaneously either crossed or did not cross the visual field meridians (See Table 1). Based on our previous work (Barnas & Greenberg, 2016), we expected to replicate our result in which no SDA emerged when both the object boundaries and invalid target

locations did not cross the visual field meridians. Conversely, when both the object boundaries and invalid target locations crossed the visual field meridians, we predicted a significant SDA, driven largely by enhanced detection (faster RTs) of invalid targets located across the vertical meridian than across the horizontal meridian. This pattern of performance would confirm that meridian crossings of both the object boundaries and invalid target locations may be factors in the emergence of the SDA.

Table 1. Object-target configurations for Experiments 1-3B.

	Experiment				
	1	2A	2B	3A	3B
Crossing object and targets	✓	✓		✓	
Non-crossing object and targets	✓		✓		✓
Crossing object, non-crossing targets		✓			✓
Non-crossing object, crossing targets			✓	✓	

*Note.* In Experiment 1, both the object boundaries and the locations of invalid targets either crossed or did not cross the meridians. In Experiments 2A and 2B, object placement was held constant while invalid target locations were manipulated. In Experiments 3A and 3B, invalid target locations were held constant object placement was manipulated.

## Method

Here, we used the ‘L’-shaped object stimuli introduced by Barnas & Greenberg (2016) to examine the relevance of object placement and invalid target location on the SDA.

**Participants.** Using the effect size from our first demonstration of the shift direction anisotropy ( $\eta_p^2 = 0.72$ ; Experiment 1 of Barnas & Greenberg, 2016), a power analysis was conducted with G\*Power (Version 3.1; Faul, Erdfelder, Buchner, & Lang, 2009). For  $\alpha = .05$  and 95% power, the computed suggested sample size was 10. However, here and in subsequent experiments, more participants were sampled in order to account for the number of participants ultimately excluded from the final sample due to high false alarm and/or miss rates and to approximate the sample sizes from our previous demonstrations of the SDA.

Forty-three individuals ( $M_{\text{age}} = 21.07$  years,  $SD_{\text{age}} = 5.95$  years; 31 women, 12 men) from the University of Wisconsin-Milwaukee (UWM) and surrounding community participated in this experiment. The study was approved by the UWM Institutional Review Board. Here and in subsequent experiments, all participants provided written informed consent prior to the start of the experiment, indicated that they had normal or corrected-to-normal visual acuity, and had the option of receiving 1 hour of extra credit toward a Psychology course or the standard hourly pay rate of \$10 as compensation for their participation.

**Apparatus and stimuli.** All stimuli were presented using a 17-in. CRT monitor, with a refresh rate of 100-Hz and a resolution of 1,024 x 768 pixels. Stimuli were generated on an Apple Mac Mini computer running OS X (Version 10.8.5) and programmed in the GNU Octave software platform (Bateman et al., 2015) using Psychophysics Toolbox extensions (Brainard, 1997; Pelli, 1997). Participants viewed the stimuli binocularly and performed the experiment in a dimly lit room while seated in an adjustable chair. A chin rest was used to support and stabilize participants' heads at a distance of approximately 58 cm throughout the experiment.

Participants fixated centrally on a white fixation cross ( $0.2^\circ \times 0.2^\circ$ ) of a fixed-width font (Monaco, font size 20), and viewed a single median gray object (RGB: [128 128 128]) that consisted of a vertical rectangle conjoined at a 90-degree angle with a horizontal rectangle, forming a unified 'L'-shaped object, on a black background. On half of the trials, the 'L'-shaped object was composed of a  $2.0^\circ \times 14.0^\circ$  vertical component rectangle and a  $14.0^\circ \times 2.0^\circ$  horizontal component rectangle (See Fig. 6; "Crossing Object and Targets"). The vertex of the 'L'-shaped object was randomly positioned in one of four locations (one per screen quadrant) such that the boundaries of one object component always crossed the vertical screen meridian and the boundaries of the other component always crossed the horizontal screen meridian. The

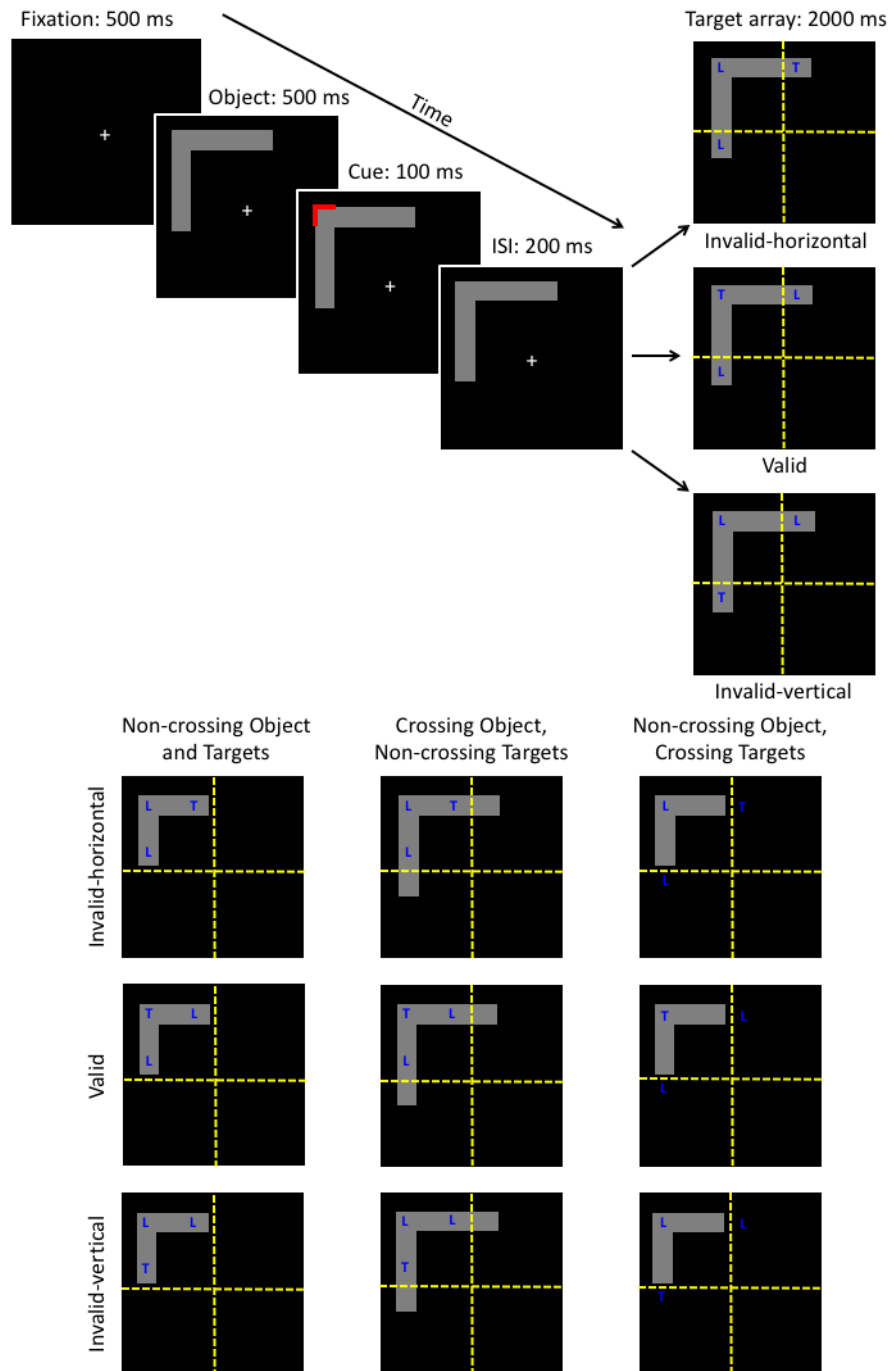

**Figure 6.** Trial sequence and object-target configurations for Experiments 1-4. **(Top)** Trial sequence for “Crossing Object and Targets”. Trial conditions were defined by the location of the blue target ‘T’ in relation to the red peripheral cue at the object vertex. **(Bottom)** Object-target configurations for “Non-crossing Object and Targets”, “Crossing Object, Non-crossing Targets”, and “Non-crossing Object, Crossing Targets” for each trial condition. *Note:* Placement of object boundaries and locations of invalid targets in relation to the visual field meridians are not drawn to scale; dotted yellow lines represent the horizontal and vertical meridians and were not visible to participants during the experiment; trial sequence was the same for each object-target configuration across experiments.

“crossing” ‘L’-shaped object was placed such that its nearest edge was  $2.67^\circ$  above or below the horizontal meridian and  $2.67^\circ$  to the left or right of the vertical meridian, depending on the location of the object’s vertex on the screen.

The other half of trials consisted of an ‘L’-shaped object that was composed of a  $2.0^\circ \times 10.65^\circ$  vertical component rectangle and a  $10.65^\circ \times 2.0^\circ$  horizontal component rectangle (See Fig. 6; “Non-crossing Object and Targets”). The vertex was also randomly positioned in one screen quadrant; however, the boundaries of the horizontal and vertical object components did not cross either screen meridian. This “non-crossing” ‘L’-shaped object was placed such that its nearest edge was  $0.67^\circ$  above or below the horizontal meridian and  $0.67^\circ$  to the left or right of the vertical meridian, depending on the location of the object’s vertex on the screen. Both crossing and non-crossing ‘L’-shaped objects were situated on the screen such that the distance from the vertical screen meridian to the inner edge of the vertical component rectangle matched the distance from the horizontal screen meridian to the inner edge of the horizontal component rectangle, both being  $9.33^\circ$ .

A red exogenous cue (RGB: [255 0 0]) also consisted of a vertical component rectangle ( $0.34^\circ \times 2.0^\circ$ ) conjoined at a 90-degree angle with a horizontal component rectangle ( $2.0^\circ \times 0.34^\circ$ ), and always appeared surrounding the outer edge of the object vertex. Though 100% predictive, the cue still served to exogenously guide spatial attention to the object vertex and selection of the ‘L’-shaped object. The target array consisted of blue letters (RGB: [0 0 255]; Monaco, font size 20) subtending  $0.67^\circ$  in length and width and consisted of a single target (the letter ‘T’) among two non-targets (the letter ‘L’). Target and non-target letters were centered left-to-right within the vertical component rectangle and top-to-bottom within the horizontal component rectangle. Letters were positioned so that their centers were  $1.0^\circ$  from the near end of

either component rectangle. Target and non-target letters on the vertical component rectangle and the horizontal component rectangle for any given ‘L’-shaped object were equidistant from the peripheral cue at the object vertex.

**Design.** The following three trial conditions were defined by the location of the target ‘T’ at: (1) the cued location at the object vertex (valid condition), (2) the far end of the object’s horizontal component rectangle (invalid-horizontal condition), or (3) the far end of the object’s vertical component rectangle (invalid-vertical condition). There were 6 blocks, each containing 160 trials for a total of 960 trials. Crossing and non-crossing conditions were randomly intermixed within blocks. That is, participants were equally likely to get a crossing or non-crossing condition on any given trial. Each block consisted of 60% valid trials (96 trials per block; 576 total), 10% invalid-horizontal trials (16 trials per block; 96 total), and 10% invalid-vertical trials (16 trials per block; 96 total). To ensure selective responding, the remaining trials were composed of “catch trials” (20%; 32 trials per block; 192 total) in which only non-target letters appeared on the object. These proportions were split evenly between the two object extent conditions, such that each condition was allotted an equivalent number of trials (e.g., 8 invalid-horizontal trials per block for crossing and non-crossing conditions, or a total of 48 invalid-horizontal trials per condition).

**Procedure.** Before beginning the experiment, participants were instructed to maintain fixation on the central cross present throughout each trial. As shown in Figure 1A, trials began with a white fixation cross presented alone for 500 ms, which was immediately followed by the appearance of an ‘L’-shaped object for 500 ms. The red cue was then displayed for 100 ms and, following a 200 ms inter-stimulus interval (300 ms cue-target SOA) from the offset of the cue, the target array appeared for 2000 ms or until a response was detected. The target letter (‘T’)

randomly appeared in one of the three possible locations (excluding catch trials). Non-targets ('L') also appeared, as placeholders, on the object in the locations that did not contain the target letter. Participants performed a detection task (RTs were recorded) and were instructed to respond as quickly and accurately as possible to the presence of the target letter while minimizing false alarms on catch trials and misses on target-present trials. The subsequent trial began following a randomly selected inter-trial interval of 400, 600, or 800 ms.

## Results

**Data quality.** Prior to conducting any statistical analyses, individual participant data were first checked for excessively high false alarm rates (responding on target absent trials) and miss rates (failing to respond on target present trials). Here and in all subsequent experiments, participants who responded to more than 48 catch trials (or, a 25% false alarm rate) and/or missed 96 target-present trials (or, a 10% miss rate) were discarded from the original sample. These exclusion criteria were established because extreme false alarm and/or miss rates are indicative of disengagement in the task. The original sample of 43 participants had a mean false alarm rate of 19% ( $SD = 18\%$ ) and a mean miss rate of 9% ( $SD = 13\%$ ). Fifteen participants with an excessively high false alarm rate ( $n = 9$ ;  $M = 47\%$ ,  $SD = 16\%$ ) on catch trials and/or miss rate ( $n = 10$ ;  $M = 25\%$ ,  $SD = 18\%$ ) on target-present trials were discarded<sup>1</sup>. This resulted in a final sample of 28 participants ( $M_{\text{age}} = 19.82$  years,  $SD_{\text{age}} = 2.20$  years; 22 women, 6 men) with a mean false alarm rate of 10% ( $SD = 6\%$ ) and a mean miss rate of 3% ( $SD = 2\%$ ). Independent

---

<sup>1</sup>Based on our predefined exclusion criteria, approximately 35% of participants were eliminated from Experiment 1. Although there are no standardized exclusion criteria in the literature, the number of participants that were excluded from the present experiment approximates the exclusion rates observed previously in studies of object-based attention that also used a target-detection task. For instance, Nah and colleagues (2018; Experiment 4) removed 30% of participants from their sample, and Kravitz and Behrmann (2011; Experiment 3) removed 37% of participants.

samples  $t$ -tests revealed a significantly larger false alarm rate,  $t(8.72) = 6.81, p \leq .001, d = 3.08$ , and miss rate,  $t(9.10) = 3.84, p = .004, d = 1.71$ , for the excluded participants compared to the included participants. Additionally, anticipatory responses (RT less than 200 ms) were discarded.

Table 2. Mean raw RTs (ms) for correct responses in Experiments 1-3B.

	Trial Condition			
	Invalid- horizontal	Invalid- vertical	Valid	SDA
Experiment 1				
Crossing object and targets	785.43 (8.12)	832.92 (11.49)	580.30 (12.89)	<b>47.49</b> <b>(20.13)</b>
Non-crossing object and targets	729.54 (8.15)	746.42 (12.60)	567.81 (12.60)	16.88 (16.06)
Experiment 2				
Crossing object and targets	799.61 (9.83)	849.26 (10.45)	543.87 (13.77)	<b>49.64</b> <b>(24.72)</b>
Crossing object, non-crossing targets	718.99 (10.03)	739.31 (8.53)	538.78 (11.82)	20.32 (20.79)
Experiment 2B				
Non-crossing object, crossing targets	910.47 (10.48)	870.32 (9.12)	548.20 (13.72)	<b>-40.14</b> <b>(26.47)</b>
Non-crossing object and targets	737.73 (10.09)	757.74 (10.89)	549.42 (14.78)	20.01 (17.61)
Experiment 3A				
Crossing object and targets	795.14 (8.92)	857.06 (7.64)	531.42 (10.73)	<b>61.91</b> <b>(21.99)</b>
Non-crossing object, crossing targets	903.06 (12.99)	836.18 (9.14)	518.55 (9.80)	<b>-66.88</b> <b>(23.64)</b>
Experiment 3B				
Crossing object, non-crossing targets	677.36 (5.55)	674.22 (8.83)	536.52 (9.60)	-3.15 (14.08)
Non-crossing object and targets	678.00 (5.89)	689.62 (8.55)	521.80 (7.91)	11.62 (12.97)

*Note.* Across all experiments, there were significant space-based cueing effects such that valid RTs were significantly faster than invalid RTs, all  $ps < .001$ . SDA = invalid-vertical RTs minus invalid-horizontal RTs. Significant SDAs are bolded. Values in parentheses are *SEMs*.

**Response latencies.** The dependent variable was mean RT for correct responses, reported in Table 2. First, mean RT differences were calculated by subtracting mean raw RTs to valid

targets from mean RTs to invalid-horizontal targets and invalid-vertical targets. Next, mean RT differences were submitted to a 2 x 2 repeated measures ANOVA with Element (boundaries and targets: meridian crossing, meridian non-crossing) and Shift Direction (horizontal, vertical) as within-subjects factors. The analysis revealed a main effect of Element,  $F(1,27) = 45.83, p < .001, \eta_p^2 = .63$ , indicating a significant difference in invalid target detection RT when reallocating object-based attention when both the object boundaries and invalid target locations crossed the meridians ( $M = 228.88$  ms,  $SEM = 19.33$  ms) versus when both the object boundaries and invalid target locations did not cross the meridians ( $M = 170.17$  ms,  $SEM = 16.54$  ms). Furthermore, the analysis revealed a main effect of Shift Direction,  $F(1,27) = 7.50, p = .011, \eta_p^2 = .22$ , indicating a significant difference in invalid target detection RT when reallocating object-based attention horizontally ( $M = 183.43$  ms,  $SEM = 15.82$  ms) versus vertically ( $M = 215.62$  ms,  $SEM = 20.70$  ms). These main effects were further qualified by a significant two-way interaction,  $F(1,27) = 5.50, p = .027, \eta_p^2 = .17$ .

The interaction between Element and Shift Direction describes the significant differences in the magnitude of the SDA as a function of whether the boundaries of the 'L'-shaped object and invalid target locations simultaneously crossed or did not cross the visual field meridians (See Fig. 7). For crossing 'L'-shaped objects and invalid target locations that necessitated shifts of attention across the meridians, a paired samples *t*-test revealed a significant SDA, such that reallocating object-based attention horizontally ( $M = 205.13$  ms,  $SEM = 7.58$  ms) was significantly faster than reallocating vertically ( $M = 252.63$  ms,  $SEM = 7.58$  ms),  $t(27) = 3.13, p = .004, d = 0.43$ . However, for non-crossing 'L'-shaped objects and invalid target locations that did not necessitate shifts of object-based attention across the meridians, a paired samples *t*-test revealed no SDA, such that horizontal shifts of attention ( $M = 161.73$  ms,  $SEM = 5.73$  ms) were

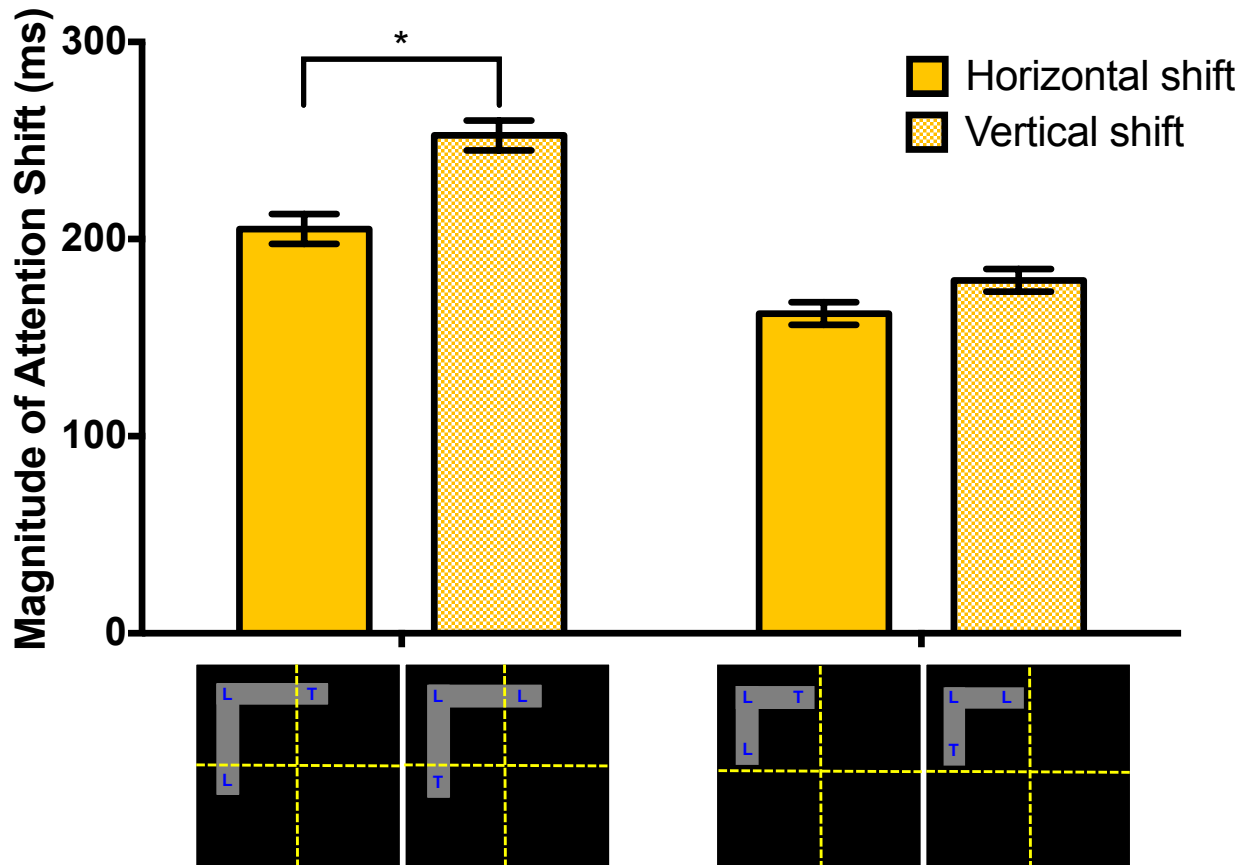

**Figure 7. Mean response latencies in Experiment 1 (yoked object boundaries and target locations).** “Magnitude of Attention Shift” measured for the Element (Boundaries and Targets) x Shift Direction interaction in Experiment 1. The error bars represent the standard error of the mean for within-subjects design.

statistically equivalent to vertical shifts of attention ( $M = 178.61$ ,  $SEM = 5.73$  ms),  $t(27) = 1.47$ ,  $p = .153$ ,  $d = 0.18$ . We computed the JZS Bayes Factor (see Rouder, Speckman, Sun, Morey, & Iverson, 2009) for the SDA in the non-crossing condition to quantify the likelihood that the null hypothesis was true. The JZS Bayes Factor was 1.91, suggesting that the null hypothesis (that horizontal shift RTs were equivalent to vertical shift RTs) was roughly twice as likely to be true as was the alternative hypothesis (that there was a difference between horizontal and vertical shift RTs). Thus, the interaction between Element and Shift Direction was driven by a significantly larger and positive (i.e., a horizontal advantage) SDA when both the object

boundaries and invalid target locations crossed the meridians (47.49 ms) versus when they did not cross the meridians (16.88 ms).

In order to understand what might have been happening with the individuals who were excluded due to our predefined criteria, we conducted a parallel ANOVA with all 43 participants from whom data were collected. We observed a similar main effect of Element,  $F(1,42) = 14.82$ ,  $p < .001$ ,  $\eta_p^2 = .26$ , and a marginally significant two-way interaction,  $F(1,42) = 3.27$ ,  $p = .078$ ,  $\eta_p^2 = .07$ . However, the main effect of Shift Direction did not reach significance,  $F(1,42) = 0.05$ ,  $p = .831$ ,  $\eta_p^2 = .00$ . Adding in the data from excluded participants increased the variability and overall noise in the combined data set. Further examination of the excluded data revealed that the mean RT differences were negative, indicating that valid RTs were slower than invalid RTs. This pattern of performance suggests that the excluded participations were, in addition to being unfocused during the task, unsuccessful in capitalizing on the informative nature of the cue to guide space-based attentional resources to the validly cued target locations. In other words, these individuals may have been ignoring the spatial cue, which further justifies excluding them from the principal analysis.

**Error rates.** Mean error rates for each trial condition are reported in Table 3. These values were submitted to a 2 x 3 repeated measures ANOVA with Element (boundaries and targets: meridian crossing, meridian non-crossing) and Trial Condition (invalid-horizontal, and invalid-vertical, and valid) as within-subjects factors. There were no significant main effects or interactions, all  $F$ s  $< 2$ , all  $p$ s  $> .2$ , nor any significant pairwise comparisons, all  $t$ s  $< 2$ , all  $p$ s  $> .1$ , indicating no statistically significant differences in error rates across trial conditions.

Table 3. Mean error rates (percent of misses) in Experiments 1-3B.

	Trial Condition		
	Invalid- horizontal	Invalid- vertical	Valid
Experiment 1			
Crossing object and targets	3.79 (0.69)	3.42 (0.58)	3.34 (0.44)
Non-crossing object and targets	2.98 (0.62)	4.02 (0.61)	3.47 (0.52)
Experiment 2			
Crossing object and targets	2.16 (0.67)	2.31 (0.71)	1.75 (0.41)
Crossing object, non-crossing targets	1.64 (0.47)	2.31 (0.70)	2.00 (0.51)
Experiment 2B			
Non-crossing object, crossing targets	2.36 (0.50)	2.22 (0.42)	2.15 (0.36)
Non-crossing object and targets	1.74 (0.36)	2.36 (0.55)	2.00 (0.37)
Experiment 3A			
Crossing object and targets	2.23 (0.44)	1.94 (0.43)	2.06 (0.45)
Non-crossing object, crossing targets	2.60 (0.55)	2.60 (0.59)	2.10 (0.47)
Experiment 3B			
Crossing object, non-crossing targets	2.87 (0.62)	2.37 (0.62)	2.53 (0.43)
Non-crossing object and targets	2.73 (0.69)	3.45 (0.70)	2.69 (0.48)

*Note.* Values in parentheses are *SEMs*.

## Discussion

Similar to our previous published findings (Barnas & Greenberg, 2016), the results from Experiment 1 revealed that horizontal shifts of object-based attention across the vertical meridian were significantly faster than vertical shifts across the horizontal meridian. This effect, however, only occurred when the object boundaries and invalid target locations crossed the visual field meridians; horizontal and vertical shifts of attention were allocated with equal efficiency when the object boundaries and invalid target locations did not cross the meridians. Therefore, a significant horizontal advantage SDA was observed for meridian crossings, but not for non-crossings. Because the invalid-horizontal and invalid-vertical target locations were equidistant from the peripheral cue (and located on the same object), current theories of object-based attention would predict that shifts of attention to these targets should be isotropic rather than anisotropic. However, we observed a significant SDA for object/target crossings, suggesting that

the performance difference between horizontal and vertical shifts of attention emerges whenever the object and associated invalid target locations cross the meridians. Taken together, these results support our hypothesis that the horizontal advantage SDA depends on object-based attention meridian crossings.

The pattern of performance observed in Experiment 1 suggests that meridian crossings of object-based attention are important factors for the emergence of the SDA. However, it remains unknown whether concurrent crossings of both object boundaries and target locations are necessary for the production of the SDA, or whether one component, alone, is responsible for this effect. Therefore, in subsequent experiments, we individually manipulated the relation between the invalid target locations and the meridians (Experiments 2A and 2B) along with the relation between the object boundaries and the meridians (Experiments 3A and 3B) while, at the same time, holding constant the non-manipulated factor.

#### **Experiments 2A and 2B: Object boundaries constant; invalid target locations vary**

The findings from Experiment 1 showed that simultaneous meridian crossings of the object boundaries and invalid target locations result in a significant horizontal advantage SDA. The goal of Experiments 2A and 2B was to assess the specific role of invalid target location on the SDA. We, therefore, held the object boundaries constant (object boundaries *always* crossed the meridians in Experiment 2A, and *never* crossed the meridians in Experiment 2B), but the invalid target locations varied (See Table 1). In Experiment 2B, invalid targets appeared external to the object boundaries. It is, therefore, reasonable to assume that the mode of attentional selection in this case would not be object-based in its purest form. Nevertheless, previous work has investigated the extent to which attention is facilitated in the surround of an object during object-based attentional selection (Kravitz & Behrmann, 2008; see also Greenberg et al., 2015).

Those authors showed that targets external to the boundaries of an attended object received some of the attentional facilitation afforded to targets within the boundaries of the cued object. Thus, it has been suggested that the boundaries of an object slow the spread of the attentional gradient into the surround rather restricting or preventing it from spreading (Hollingworth, Maxcey-Richard, & Vecera, 2012). For the “non-crossing object, crossing targets” configuration, the external targets would still, in theory, benefit from the attentional gradient afforded to the object.

Based on our results from Experiment 1, we hypothesized, for Experiment 2A, that (1) a significant SDA would emerge when both the object boundaries and invalid target locations crossed the meridians and (2) no SDA would emerge when the invalid target locations did not cross the meridians, despite being contained within the boundaries of an object that did cross the meridians. For Experiment 2B, we hypothesized that (1) a significant SDA would emerge when the invalid target locations crossed the meridians, despite appearing while an attended object did not cross the meridians and (2) no SDA would emerge when both the object boundaries and invalid target locations did not cross the meridians. This pattern of performance would suggest that invalid target locations (and not object boundaries) requiring shifts of attention across the visual field meridians are necessary and sufficient for the emergence of the SDA.

## **Method**

**Experiment 2A (object boundaries always cross meridians).** All aspects of Experiment 2A were identical to those of Experiment 1, except as described below.

**Participants.** Thirty-six new individuals from the University of Wisconsin-Milwaukee and surrounding community ( $M_{\text{age}} = 21.69$  years,  $SD_{\text{age}} = 3.11$  years; 30 women, 6 men) participated in this experiment.

**Apparatus, stimuli, design, and procedure.** On all trials, the ‘L’-shaped object was composed of a  $2.0^\circ \times 14.0^\circ$  vertical component rectangle conjoined at a 90-degree angle with a  $14.0^\circ \times 2.0^\circ$  horizontal component rectangle. On half of the trials, the target array consisted of target and non-target letters that were positioned so that their centers were  $1.0^\circ$  from the near end of either component rectangle (See Fig. 6; “Crossing Object and Targets”), while the other half consisted of a target array in which target and non-target letters were positioned so that their centers were  $4.33^\circ$  from the near end of either component rectangle (See Fig. 6; “Crossing Object, Non-crossing Targets”). Crossing and non-crossing target conditions were randomly intermixed within blocks and were equally likely to appear on any given trial.

**Experiment 2B (object boundaries never cross meridians).** All aspects of Experiment 2B were identical to those of Experiment 1, except as described below.

**Participants.** Thirty-three new individuals from the University of Wisconsin-Milwaukee and surrounding community ( $M_{\text{age}} = 22.48$  years,  $SD_{\text{age}} = 9.70$  years; 26 women, 7 men) participated in this experiment.

**Apparatus, stimuli, design, and procedure.** On all trials, the ‘L’-shaped object was composed of a  $2.0^\circ \times 10.65^\circ$  vertical component rectangle conjoined at a 90-degree angle with a  $10.65^\circ \times 2.0^\circ$  horizontal component rectangle. On half of the trials, the target array consisted of target and non-target letters that were positioned so that their centers were  $4.33^\circ$  from the near end of either component rectangle, appearing external to the object (See Fig. 6, “Non-crossing Object, Crossing Targets”), while the other half consisted of a target array in which target and non-target letters were positioned so that their centers were  $1.0^\circ$  from the near end of either component rectangle (See Fig. 6, “Non-crossing Object and Targets”). Crossing and non-

crossing target conditions were randomly intermixed within blocks and were equally likely to appear on any given trial.

## Results

### Experiment 2A.

**Data Quality.** The original sample of 36 participants had a mean false alarm rate of 15% ( $SD = 17\%$ ) and a mean miss rate of 3% ( $SD = 4\%$ ). Using the same exclusion criteria from Experiment 1, a total of 8 participants with an excessively high false alarm rate ( $n = 8$ ;  $M = 43\%$ ,  $SD = 11\%$ ) on catch trials and/or number of misses ( $n = 1$ ;  $N = 125$  trials) on target-present trials were discarded. This resulted in a final sample of 28 participants ( $M_{\text{age}} = 21.71$  years,  $SD_{\text{age}} = 3.29$  years; 25 women, 3 men) with a mean false alarm rate of 7% ( $SD = 6\%$ ) and a mean miss rate of 2% ( $SD = 2\%$ ). An independent samples  $t$ -test revealed a significantly larger false alarm rate for the excluded participants compared to the included participants,  $t(7.99) = 8.54$ ,  $p < .001$ ,  $d = 3.96$ . As in Experiment 1, anticipatory responses (RT less than 200 ms) were discarded.

**Response latencies.** The dependent variable was the mean RT for correct responses, reported in Table 2. As in Experiment 1, mean RT differences were calculated by subtracting mean raw RTs to valid targets from mean RTs to invalid-horizontal targets and invalid-vertical targets. Next, mean RT differences were submitted to a 2 x 2 repeated measures ANOVA with Element (targets: meridian crossing, meridian non-crossing) and Shift Direction (horizontal, vertical) as within-subjects factors. The analysis revealed a main effect of Element,  $F(1,27) = 141.56$ ,  $p < .001$ ,  $\eta_p^2 = .84$ , indicating a significant difference in mean RT while reallocating object-based attention to invalid target locations that crossed the meridians ( $M = 280.56$  ms,  $SEM = 10.65$  ms) versus target locations that did not cross the meridians ( $M = 190.37$  ms,  $SEM = 17.69$  ms). Furthermore, the analysis revealed a main effect of Shift Direction,  $F(1,27) = 9.45$ ,  $p$

= .005,  $\eta_p^2 = .26$ , indicating a significant difference in mean RT when shifting attention horizontally ( $M = 217.98$  ms,  $SEM = 19.42$  ms) versus vertically ( $M = 252.96$  ms,  $SEM = 19.96$  ms). These main effects were further qualified by a significant two-way interaction,  $F(1,27) = 4.92$ ,  $p = .035$ ,  $\eta_p^2 = .15$ .

For invalid target locations that necessitated shifts of attention across the meridians, a paired samples  $t$ -test revealed a significant SDA, such that reallocating object-based attention horizontally ( $M = 255.74$  ms,  $SEM = 7.45$  ms) was significantly faster than vertically ( $M = 305.38$  ms,  $SEM = 7.45$  ms),  $t(27) = 3.33$ ,  $p = .003$ ,  $d = 0.43$ . However, for invalid target locations that did not necessitate shifts of attention across the meridians, a paired samples  $t$ -test revealed no SDA, such that horizontal shifts of attention ( $M = 180.21$  ms,  $SEM = 5.58$  ms) were statistically equivalent to vertical shifts ( $M = 200.54$  ms,  $SEM = 5.58$  ms),  $t(27) = 1.82$ ,  $p = .080$ ,  $d = 0.21$  (see Fig 8). The JZS Bayes Factor was 1.17, suggesting that the null hypothesis was likely to be true. Thus, the interaction between Element and Shift Direction was driven by a significantly larger and positive (i.e., a horizontal advantage) SDA between horizontal and vertical shifts of object-based attention when invalid target locations crossed the meridians (49.64 ms) versus when they did not cross the meridians (20.32 ms).

Mirroring our analysis of Experiment 1, we conducted a parallel ANOVA with all 36 participants from whom data were collected. We observed a similar main effect of Element  $F(1,35) = 129.44$ ,  $p < .001$ ,  $\eta_p^2 = .79$ , and significant two-way interaction,  $F(1,35) = 4.38$ ,  $p = .044$ ,  $\eta_p^2 = .11$ . The main effect of Shift Direction was marginally significant,  $F(1,35) = 3.45$ ,  $p = .072$ ,  $\eta_p^2 = .09$ .

**Error rates.** Mean error rates for each trial condition are reported in Table 3. As in Experiment 1, these values were submitted to a 2 x 3 repeated measures ANOVA with Element

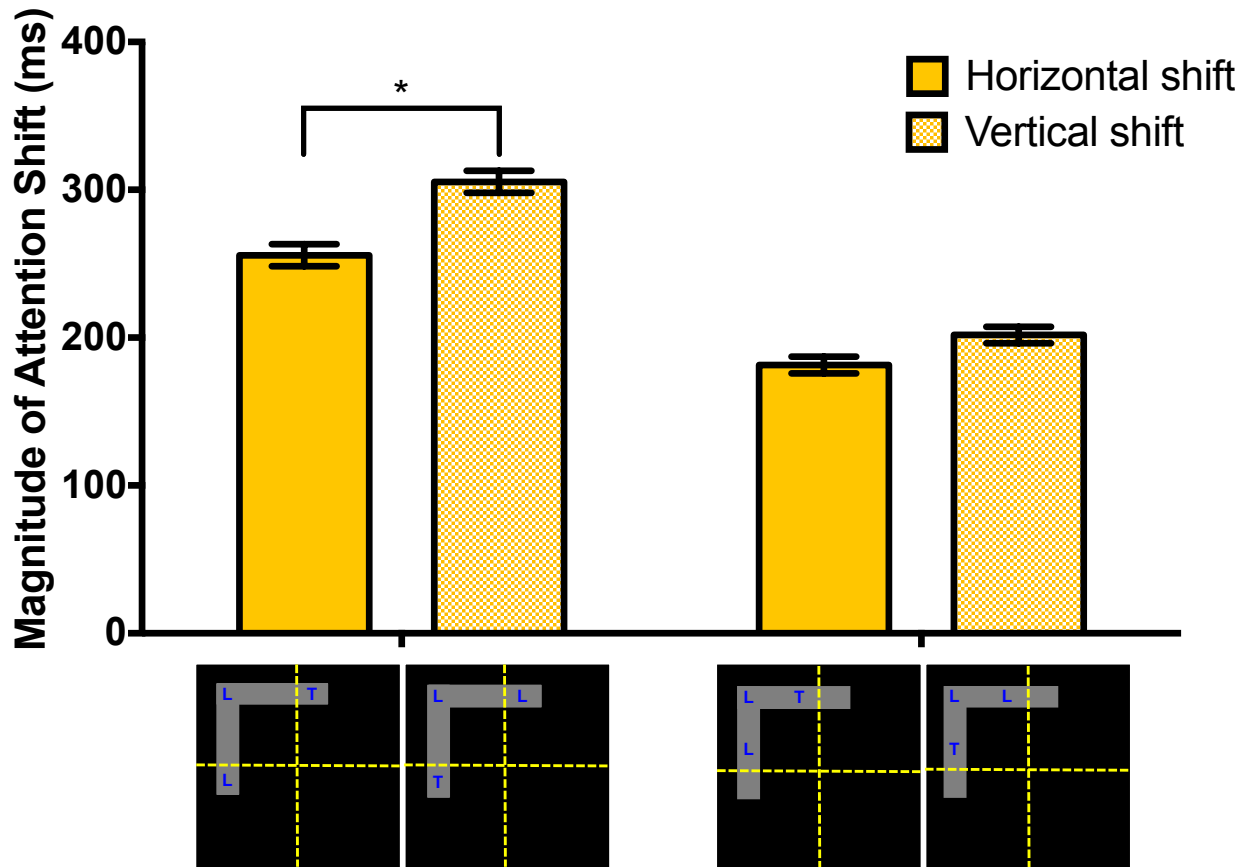

**Figure 8.** Mean response latencies in Experiment 2A (object boundaries always cross meridians). “Magnitude of Attention Shift” measured for the Element (Targets) x Shift Direction interaction in Experiment 2A. The error bars represent the standard error of the mean for within-subjects design.

(targets: meridian crossing, meridian non-crossing) and Trial Condition (invalid-horizontal, and invalid-vertical, and valid) as within-subjects factors. There were no significant main effects or interactions, all  $F_s < 2$ , all  $p_s > .2$ , nor any significant pairwise comparisons, all  $t_s < 2$ , all  $p_s > .2$ , indicating no statistically significant differences in error rates across trial conditions.

### Experiment 2B.

**Data Quality.** The original sample of 33 participants had a mean false alarm rate of 10% ( $SD = 9\%$ ) and a mean miss rate of 3% ( $SD = 4\%$ ). Using the same exclusion criteria from Experiment 1, a total of 3 participants with an excessively high false alarm rate ( $n = 2$ ;  $M = 32\%$ ,

$SD = 6\%$ ) on catch trials and/or miss rate ( $n = 2$ ;  $M = 16\%$ ,  $SD = 4\%$ ) on target-present trials were discarded. This resulted in a final sample of 30 participants ( $M_{\text{age}} = 22.87$  years,  $SD_{\text{age}} = 10.11$  years; 24 women, 6 men) with a mean false alarm rate of 8% ( $SD = 7\%$ ) and a mean miss rate of 2% ( $SD = 2\%$ ). Independent samples  $t$ -tests revealed no significant differences in false alarm rates,  $t(1.20) = 5.05$ ,  $p = .094$ ,  $d = 3.39$ , or miss rates,  $t(1.04) = 5.25$ ,  $p = .113$ ,  $d = 4.70$ , between the excluded and included participants. Again, anticipatory responses (less than 200 ms) were discarded.

**Response latencies.** The dependent variable was the mean RT for correct responses, reported in Table 2. Again, mean RT differences were calculated by subtracting mean raw RTs to valid targets from mean RTs to targets in the invalid-horizontal location and invalid-vertical location. Next, mean RT differences were submitted to a 2 x 2 repeated measures ANOVA with Element (targets: meridian crossing, meridian non-crossing) and Shift Direction (horizontal, vertical) as within-subjects factors. The analysis revealed a main effect of Element,  $F(1,29) = 148.66$ ,  $p < .001$ ,  $\eta_p^2 = .84$ , indicating a significant difference in invalid target detection RT while reallocating object-based attention to invalid target locations that crossed the meridians ( $M = 342.19$  ms,  $SEM = 20.58$  ms) versus locations that did not cross the meridians ( $M = 198.32$  ms,  $SEM = 17.07$  ms). The main effect of Shift Direction, however, was not significant,  $F(1,29) = 0.86$ ,  $p = .361$ ,  $\eta_p^2 = .03$ , indicating no significant difference in RT when shifting horizontally ( $M = 275.29$  ms,  $SEM = 18.49$  ms) versus vertically ( $M = 265.22$  ms,  $SEM = 19.02$  ms). Furthermore, the analysis revealed a significant two-way interaction,  $F(1,29) = 14.73$ ,  $p = .001$ ,  $\eta_p^2 = .34$ .

For invalid target locations that necessitated shifts of attention across the meridians, a paired samples  $t$ -test revealed a significant SDA such that reallocating object-based attention

vertically ( $M = 322.12$  ms,  $SEM = 7.03$  ms) was significantly faster than horizontally ( $M = 362.26$  ms,  $SEM = 7.03$  ms),  $t(29) = 2.85$ ,  $p = .008$ ,  $d = 0.34$ . However, for invalid target locations that did not necessitate shifts of attention across the meridians, a paired samples  $t$ -test revealed no SDA, such that horizontal shifts of attention ( $M = 188.32$  ms,  $SEM = 6.32$  ms) were statistically equivalent to vertical shifts ( $M = 208.33$  ms,  $SEM = 6.32$  ms),  $t(29) = 1.58$ ,  $p = .124$ ,  $d = 0.20$  (See Fig. 9). The JZS Bayes Factor was 1.69, in favor of the null hypothesis. Thus, the interaction between Element and Shift Direction was driven by a significantly larger and negative (a vertical advantage) SDA between horizontal and vertical shifts of object-based

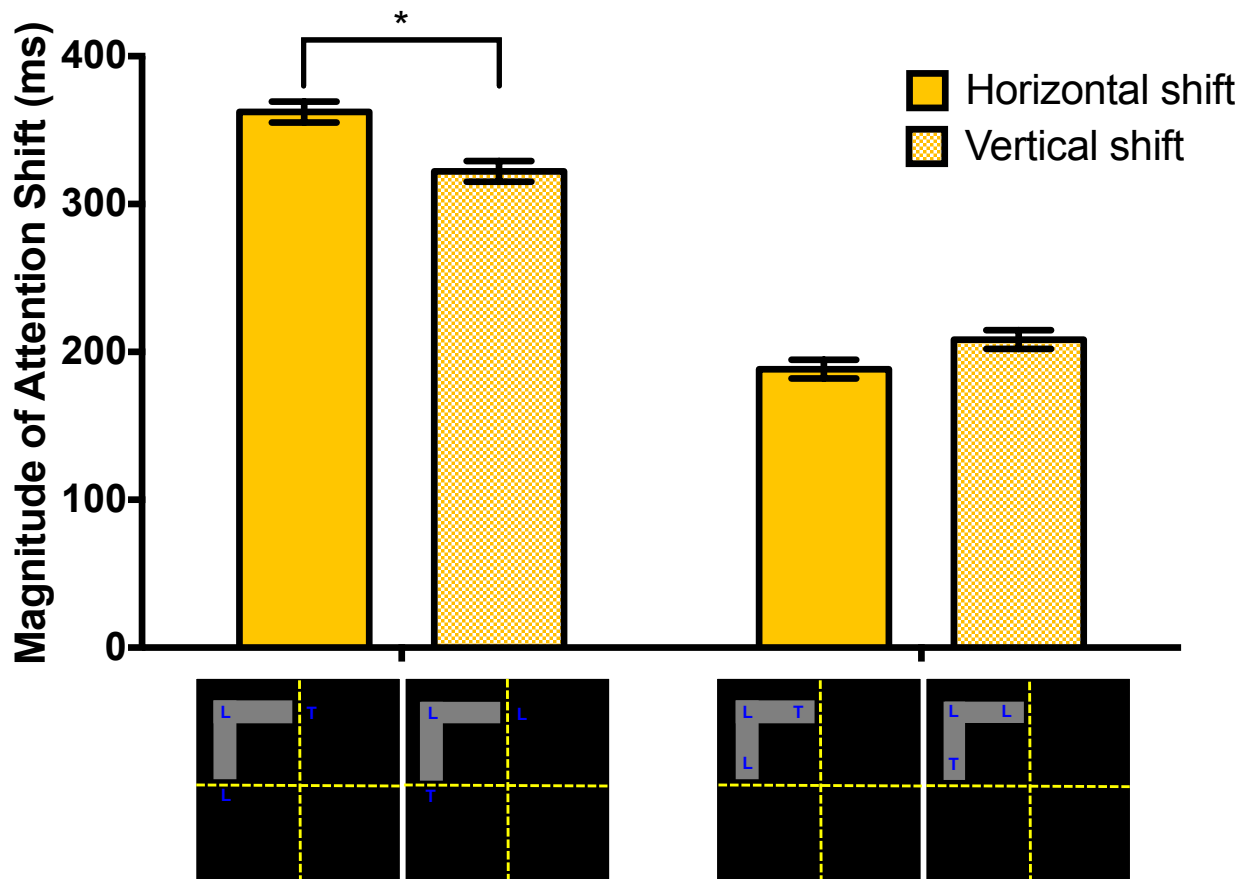

**Figure 9.** Mean response latencies in Experiment 2B (object boundaries never cross meridians). “Magnitude of Attention Shift” measured for the Element (Targets) x Shift Direction interaction in Experiment 2B. The error bars represent the standard error of the mean for within-subjects design.

attention when invalid target locations crossed the meridians (40.14 ms) versus when locations did not cross the meridians (20.01 ms).

When including all 33 participants, we observed a similar main effect of Element,  $F(1,32) = 110.16$ ,  $p \leq .001$ ,  $\eta_p^2 = .78$ , and a significant two-way interaction,  $F(1,32) = 15.68$ ,  $p \leq .001$ ,  $\eta_p^2 = .33$ . No main effect of Shift Direction was observed,  $F(1,32) = 2.71$ ,  $p = .110$ ,  $\eta_p^2 = .08$ .

***Expected vs. measured response latencies.*** A likely explanation for the negative SDA we observed in Experiment 2B may be the lack of target-object integration (cf. Al-Janabi & Greenberg, 2016). Strong target-object integration occurs when invalid targets are located within the boundaries of an attended object, whereas weak target-object integration occurs when invalid targets are located outside the boundaries of an attended object. When targets are weakly integrated with the object, participants must disengage attentional resources from the attended object and subsequently reallocate attention outside object boundaries (cf. Brown & Denny, 2007). We hypothesized that weak target-object integration, coupled with disengaging and re-engaging attentional resources, resulted in the vertical advantage SDA observed in this experiment. Following the method outlined in Barnas & Greenberg (2016), we used RTs to invalid target locations that were located inside the boundaries of the cued non-crossing object to calculate the *expected* mean RTs to invalid target locations that were located external (across the meridians) to the non-crossing object. This allowed us to compare measured vs. expected RTs and, thus, determine whether or not target-object integration modulates the direction of the SDA. To accomplish this, we first calculated the average shift velocity (time/distance) from the valid target location to the invalid target locations within the non-crossing object, and then applied these velocity measures to predict the expected mean RTs to the invalid target locations outside

of the object. This allowed us to compare whether the velocity of the attention shift was affected by the disengagement and re-engagement of attention due to weak target-object integration. That is, if the expected RT for the external invalid targets matched the measured RT, then participants were unaffected by weakly integrated targets and object (targets appearing outside the boundaries of the object). However, if the expected RT was significantly different from the measured RT for the external invalid targets, then we can postulate that participants were, indeed, affected by target-object integration. Significantly different expected and measured RTs would ultimately indicate that the visual field meridians and target-object integration modulate the magnitude and direction of the SDA.

The result of a one-sample *t*-test showed that measured attention shifts to the invalid target locations outside of the object (weak target-object integration;  $M_{measured} = 342.19$  ms) were significantly slower than expected by the velocity to the invalid target locations inside the object (strong target-object integration;  $M_{expected} = 260.70$  ms),  $t(29) = 3.70, p < .001$ . In order to ensure that this is truly an effect of weak target-object integration, we performed the same calculation on the data from Experiment 2A, in which all targets appeared within an object and, thus, were strongly integrated. No significant differences emerged between these measured and expected RTs ( $M_{measured} = 280.56$  ms,  $M_{expected} = 250.25$  ms;  $t(27) = 1.47, p = .154$ ).

**Error rates.** Mean error rates for each trial condition are reported in Table 3. Again, these values were submitted to a 2 x 3 repeated measures ANOVA with Element (targets: meridian crossing, meridian non-crossing) and Trial Condition (invalid-horizontal, and invalid-vertical, and valid) as within-subjects factors. There were no significant main effects or interactions, all  $F_s < 1$ , all  $p_s > .4$ , nor any significant pairwise comparisons, all  $t_s < 2$ , all  $p_s > .1$ , indicating no statistically significant differences in error rates across trial conditions.

## Discussion

Similar to results from Experiment 1, we observed a significant SDA between horizontal and vertical shifts of object-based attention that crossed the meridians. Although the SDA was significant when targets were located across the meridians, the sign of the SDA varied with the object boundary condition. Specifically, the SDA was positive (i.e., a horizontal advantage) when the object boundaries crossed the meridians; but the SDA was negative (i.e., a vertical advantage) when the object boundaries did not cross the meridians. To our knowledge, this is the first observation of a negative SDA. Additionally, when the invalid target locations did not cross the visual field meridians (in this case, regardless of whether or not the object boundaries crossed the meridians) we observed no significant difference between horizontal and vertical shifts. Thus, we seem to have produced some initial evidence that, when object-based shifts of attention cross the visual field meridians, target locations (and not object boundaries) drive observation of the SDA. That is to say, the anisotropy between horizontal and vertical shifts depends on targets located across the meridians, without regard to object boundary locations.

However, there is one additional point of interest that compels comment. We believe that the vertical advantage SDA is more related to target-object integration and the mode of attentional selection rather than a feature of visual field meridian crossings. In an object cueing paradigm such as this, the representational basis of attentional selection is object-based (Kahneman & Henik, 1981), meaning that greater attentional priority is afforded to locations within the cued object than locations outside the cued object. Evidence from our lab (and others) suggests that, during object-based selection, targets appearing outside the cued object require a considerable effort for attention to shift to that off-object location (cf. Greenberg et al., 2015). In fact, one could argue that this situation would no longer make use of object-based selection

mechanisms, at all; instead, using spatial attention to identify and shift to the off-object target. Here, when targets appeared outside the object boundaries we, therefore, argue that targets and object were weakly integrated and selection was no longer object-based, which caused an unusual pattern of RTs (i.e., a vertical advantage SDA) possibly due to a momentary loss of attentional control (Greenberg & Gmeindl, 2008). Further evidence in support of this claim was observed in our analysis of expected versus measured latencies based on shift velocity. Measured RTs were significantly different than expected RTs for invalid targets that crossed the meridians when located outside the boundaries of the object. However, measured RTs were not significantly different than expected RTs for targets that crossed the meridians while located inside the boundaries of the object. In the former case (targets located outside object boundaries) attention had to disengage from the object before locating the target, causing a sizeable slowing of velocity. No such change in velocity was observed in the latter case (targets located inside object boundaries). We conclude that when targets are located outside object boundaries, it illustrates a special case that is no longer of direct relevance to the efficiency of object-based attentional selection for horizontal vs. vertical shifts (which is the goal of the current study).

An alternative explanation for the vertical advantage SDA involves the balance of enhancing and suppressing attentional resources inside and outside the object. In general, there is a stronger enhancement of attentional resources horizontally versus vertically at target locations within the boundaries of an object, thus resulting in the horizontal advantage SDA. However, there must also be a stronger suppression of attentional resources horizontally versus vertically for target locations external to an object such that the strength of the suppression occurring outside the object is commensurate, or equal, with the strength of the enhancement occurring simultaneously inside the object. Therefore, a vertical advantage SDA emerged due to a weaker

suppression of attentional resources vertically compared to horizontally at target locations outside the boundaries of an object.

Taken together, these results support our hypothesis that a significant SDA emerges when target locations necessitate a shift of attention that crosses the meridians, regardless of whether or not the object boundaries cross the meridians.

### **Experiments 3A and 3B: Invalid target locations constant; object boundaries vary**

The findings from Experiments 2A and 2B showed that invalid target locations that necessitate shifts of attention across the visual field meridians are necessary for the emergence of the SDA; but we still wondered whether this was sufficient for observing the anisotropy. Having established the influence of the invalid target locations on the SDA, the goal of Experiments 3A and 3B was to assess the role of object boundaries on the SDA. We, therefore, held the invalid target locations constant (target locations *always* crossed the meridians in Experiment 3A, and *never* crossed the meridians in Experiment 3B), but the object boundaries varied (See Table 1). Based on our results from Experiments 1 & 2, we hypothesized, for Experiment 3A, that a significant SDA would emerge when the invalid target locations crossed the meridians, regardless of object position; however, for Experiment 3B, we hypothesized that no SDA would emerge when the invalid target locations did not cross the meridians, regardless of object position. This pattern of performance would suggest that, when controlling for target location, whether or not object boundaries cross the visual field meridians does not alter the emergence of the SDA.

### **Method**

**Experiment 3A (invalid target locations always cross meridians).** All aspects of Experiment 3A were identical to those of Experiment 1, except as described below.

**Participants.** Thirty-three new individuals from the University of Wisconsin-Milwaukee and surrounding community ( $M_{\text{age}} = 20.15$  years,  $SD_{\text{age}} = 2.08$  years; 28 women, 5 men) participated in this experiment.

**Apparatus, stimuli, design, and procedure.** On half of the trials, the target array consisted of target and non-target letters that were positioned so that their centers were  $1.0^\circ$  from the near end of either component rectangle (See Fig. 6, “Crossing Object and Targets”), while the other half consisted of a target array in which target and non-target letters were positioned so that their centers were  $4.33^\circ$  from the near end of either component rectangle, appearing off the object (See Fig. 6, “Non-crossing Object, Crossing Targets”). Crossing and non-crossing object conditions were randomly intermixed within blocks and were equally likely to appear on any given trial.

**Experiment 3B (invalid target locations never cross meridians).** All aspects of Experiment 3B were identical to those of Experiment 1, except as described below.

**Participants.** Thirty-nine new individuals from the University of Wisconsin-Milwaukee and surrounding community ( $M_{\text{age}} = 21.26$  years,  $SD_{\text{age}} = 2.55$  years; 27 women, 12 men) participated in this experiment.

**Apparatus, stimuli, design, and procedure.** On half of the trials, the target array consisted of target and non-target letters that were positioned so that their centers were  $4.33^\circ$  from the near end of either component rectangle (See Fig. 6, “Crossing Object, Non-crossing Targets”), while the other half consisted of a target array in which target and non-target letters were positioned so that their centers were  $1.0^\circ$  from the near end of either component rectangle (See Fig. 6, “Non-crossing Object and Targets”). Crossing and non-crossing object conditions were randomly intermixed within blocks and were equally likely to appear on any given trial.

## Results

### Experiment 3A.

**Data Quality.** The original sample of 33 participants had a mean false alarm rate of 13% ( $SD = 13\%$ ) and a mean miss rate of 4% ( $SD = 5\%$ ). Using the same exclusion criteria from Experiment 1, a total of 5 participants with an extremely high false alarm rate ( $n = 4$ ;  $M = 39\%$ ,  $SD = 14\%$ ) on catch trials and/or miss rate ( $n = 3$ ;  $M = 17\%$ ,  $SD = 3\%$ ) on target-present trials were discarded. This resulted in a final sample of 28 participants ( $M_{\text{age}} = 20.43$  years,  $SD_{\text{age}} = 2.13$  years; 24 women, 4 men) with a mean false alarm rate of 8% ( $SD = 5\%$ ) and a mean miss rate of 2% ( $SD = 2\%$ ). Independent samples  $t$ -tests revealed a significantly larger false alarm rate,  $t(3,16) = 5.18, p = .012, d = 3.41$ , and miss rate,  $t(2,22) = 7.94, p = .011, d = 5.44$ , for the excluded participants compared to the included participants. Additionally, anticipatory responses (RT less than 200 ms) were discarded.

**Response latencies.** The dependent variable was the mean RT for correct responses, reported in Table 2. As in Experiment 1, mean RT differences were calculated by subtracting mean raw RTs to valid targets from mean RTs to targets in the invalid-horizontal location and invalid-vertical location. Next, mean RT differences were submitted to a 2 x 2 repeated measures ANOVA with Element (boundaries: meridian crossing, meridian non-crossing) and Shift Direction (horizontal, vertical) as within-subject factors. The analysis revealed a main effect of Element,  $F(1,27) = 37.35, p < .001, \eta_p^2 = .58$ , indicating a significant difference in invalid target detection RT while reallocating object-based attention to invalid targets inside objects that crossed the meridians ( $M = 294.68$  ms,  $SEM = 16.10$  ms) versus targets outside objects that did not cross the meridians ( $M = 351.07$  ms,  $SEM = 15.94$  ms). The main effect of Shift Direction, however, was not significant,  $F(1,27) = 0.07, p = .789, \eta_p^2 = .003$ , indicating no significant

difference in invalid target detection RT when reallocating object-based attention horizontally ( $M = 324.12$  ms,  $SEM = 17.35$  ms) versus vertically ( $M = 321.64$  ms,  $SEM = 14.57$  ms).

Furthermore, the analysis revealed a significant two-way interaction,  $F(1,27) = 65.10$ ,  $p < .001$ ,  $\eta_p^2 = .71$ .

For objects whose boundaries crossed the meridians, a paired samples  $t$ -test revealed a significant SDA such that reallocating object-based attention horizontally ( $M = 263.72$  ms,  $SEM = 6.34$  ms) was significantly faster than vertically ( $M = 325.64$  ms,  $SEM = 6.34$  ms),  $t(27) = 4.89$ ,  $p < .001$ ,  $d = 0.68$ . Additionally, when object boundaries did not cross the meridians, a paired samples  $t$ -test revealed a significant SDA such that reallocating object-based attention vertically ( $M = 317.63$  ms,  $SEM = 5.83$  ms) was significantly faster than horizontally ( $M = 384.51$  ms,  $SEM = 5.83$  ms),  $t(27) = 5.73$ ,  $p < .001$ ,  $d = 0.74$  (See Fig. 10). Thus, the interaction between Element and Shift Direction was driven by SDAs of opposite sign. A significant positive (i.e., horizontal advantage) SDA was observed when targets appeared at locations inside the boundaries of an object that crossed the meridians (61.91 ms) and a significant negative (i.e., vertical advantage) SDA was observed when invalid target locations appeared outside the boundaries of an object that did not cross the meridians (66.88 ms).

When all 33 participants were included, we observed a similar main effect of Element,  $F(1,32) = 28.64$ ,  $p < .001$ ,  $\eta_p^2 = .47$ , and a significant two-way interaction,  $F(1,32) = 51.25$ ,  $p < .001$ ,  $\eta_p^2 = .62$ . No main effect of Shift Direction was observed,  $F(1,32) = 0.55$ ,  $p = .462$ ,  $\eta_p^2 = .02$ .

**Error rates.** Mean error rates for each trial condition are reported in Table 3. As in Experiment 1, these values were submitted to a 2 x 3 repeated measures ANOVA with Element (boundaries: meridian crossing, meridian non-crossing) and Trial Condition (invalid-horizontal,

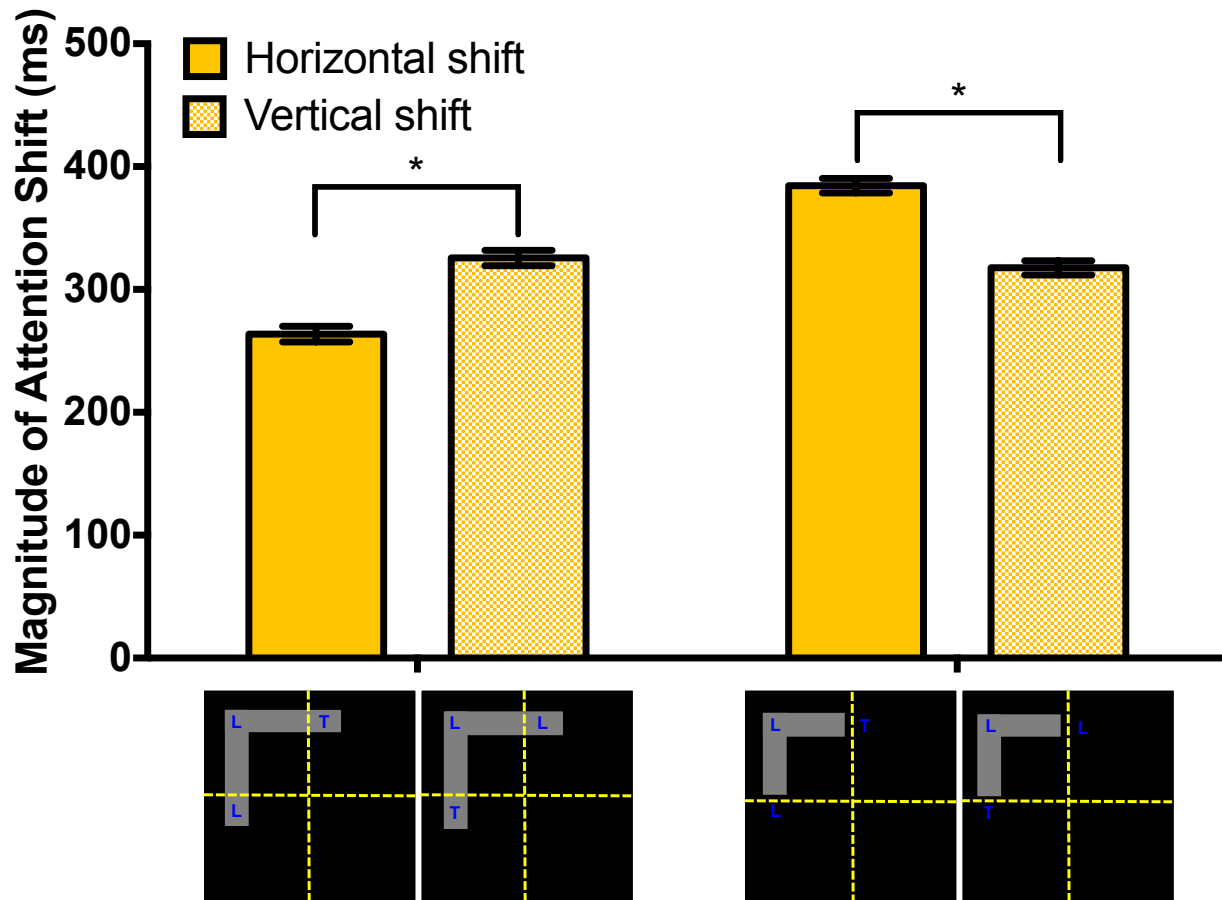

**Figure 10. Mean response latencies in Experiment 3A (invalid target locations always cross meridians).** “Magnitude of Attention Shift” measured for the Element (Boundaries) x Shift Direction interaction in Experiment 3A. The error bars represent the standard error of the mean for within-subjects design.

and invalid-vertical, and valid) as within-subjects factors. There were no significant main effects or interactions, all  $F_s < 3$ , all  $p_s > .1$ , nor any significant pairwise comparisons, all  $t_s < 2$ , all  $p_s > .1$ , indicating no statistically significant differences in error rates across trial conditions.

### Experiment 3B.

**Data Quality.** The original sample of 39 participants had a mean false alarm rate of 16% ( $SD = 16\%$ ) and a mean miss rate of 5% ( $SD = 8\%$ ). Using the same exclusion criteria from Experiment 1, a total of 10 participants with an extremely high false alarm rate ( $n = 10$ ;  $M =$

41%,  $SD = 10\%$ ) on catch trials and/or miss rate ( $n = 3$ ;  $M = 31\%$ ,  $SD = 6\%$ ) on target-present trials were discarded. This resulted in a final sample of 29 participants ( $M_{\text{age}} = 21.38$  years,  $SD_{\text{age}} = 2.66$  years; 21 women, 8 men) with a mean false alarm rate of 8% ( $SD = 6\%$ ) and a mean miss rate of 3% ( $SD = 2\%$ ). Independent samples  $t$ -tests revealed a significantly larger false alarm rate,  $t(11.09) = 10.01$ ,  $p < .001$ ,  $d = 4.10$ , and miss rate,  $t(2.07) = 8.05$ ,  $p = .014$ ,  $d = 6.16$ , for the excluded participants compared to the included participants. Again, anticipatory responses (RT less than 200 ms) were discarded.

**Response latencies.** The dependent variable was the mean RT for correct responses, reported in Table 2. Again, mean RT differences were calculated by subtracting mean raw RTs to valid targets from mean RTs to targets in the invalid-horizontal location and invalid-vertical location. Next, mean RT differences were submitted to a 2 x 2 repeated measures ANOVA with Element (boundaries: meridian crossing, meridian non-crossing) and Shift Direction (horizontal, vertical) as within-subject factors. The analysis revealed a main effect of Element,  $F(1,28) = 11.44$ ,  $p = .002$ ,  $\eta_p^2 = .29$ , indicating a significant difference in invalid target detection RT while reallocating object-based attention to invalid targets within objects that crossed the meridians ( $M = 139.28$  ms,  $SEM = 14.40$  ms) versus targets within objects that did not cross the meridians ( $M = 162.01$  ms,  $SEM = 12.59$  ms). Neither the main effect of Shift Direction nor the two-way interaction did not reach significance, all  $ps > .1$ .

Paired samples  $t$ -tests revealed no SDA for each condition, such that horizontal shifts of object-based attention were statistically equivalent to vertical shifts when the boundaries of the object crossed the meridians ( $M = 140.85$  ms,  $SEM = 5.70$  ms and 137.70 ms,  $SEM = 5.70$  ms, respectively),  $t(28) = 0.28$ ,  $p = .781$ ,  $d = 0.04$ , as well as when the boundaries of the object did not cross the meridians ( $M = 156.20$  ms,  $SEM = 3.90$  ms and 167.82 ms,  $SEM = 3.90$  ms,

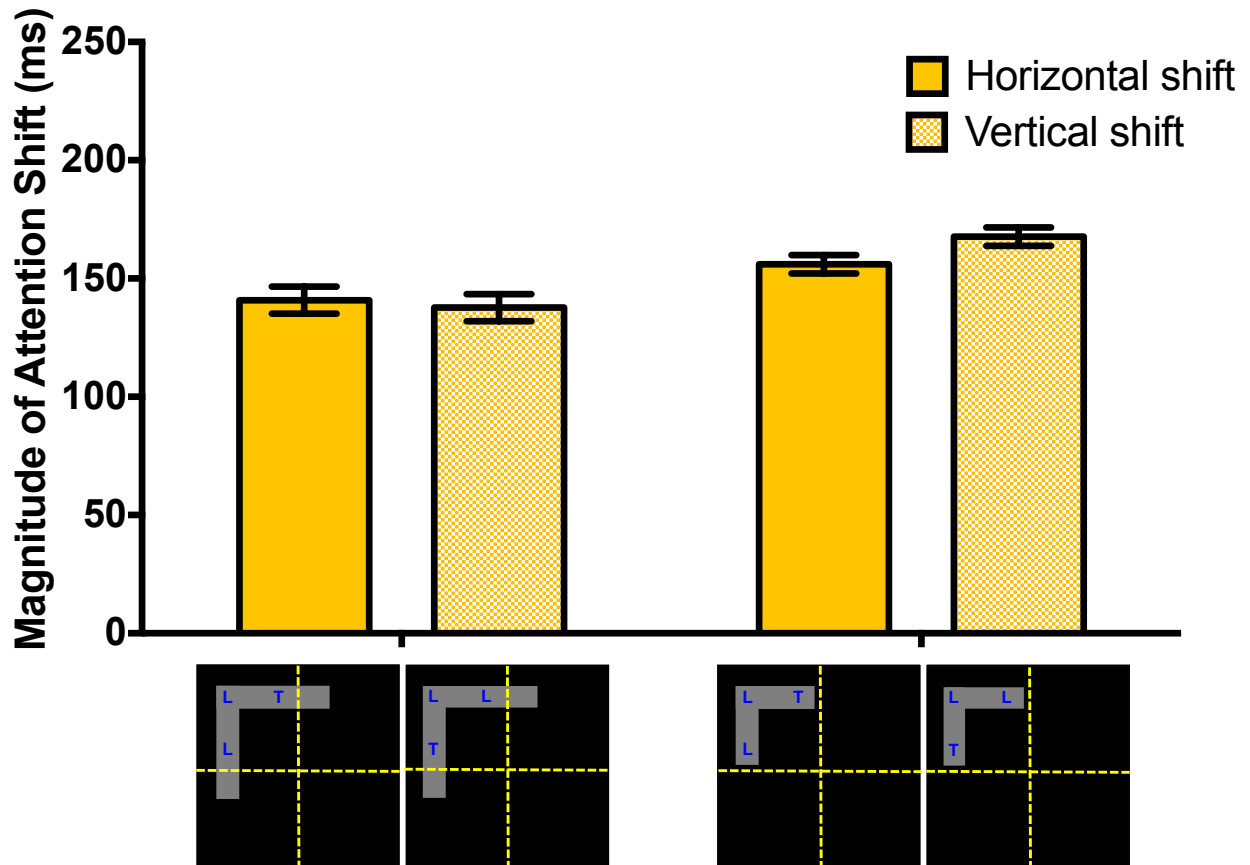

**Figure 11. Mean response latencies in Experiment 3B (invalid target locations never cross meridians).** “Magnitude of Attention Shift” measured for the Element (Boundaries) x Shift Direction interaction in Experiment 3B. The error bars represent the standard error of the mean for within-subjects design.

respectively),  $t(28) = 1.52$ ,  $p = .140$ ,  $d = 0.16$  (See Fig. 11). The JZS Bayes Factors were 4.89 and 1.81, respectively, suggesting that the null hypothesis was likely to be true in both conditions. Thus, there was no significant SDA when the boundaries of the object crossed (3.14 ms) or did not cross (11.62 ms) the meridians.

When all 39 participants were included, we observed a similar main effect of Element,  $F(1,38) = 17.13$ ,  $p < .001$ ,  $\eta_p^2 = .31$ . Neither the main effect of Shift Direction,  $F(1,38) = 0.43$ ,  $p = .518$ ,  $\eta_p^2 = .01$ , nor the two-way interaction,  $F(1,38) = 2.46$ ,  $p = .125$ ,  $\eta_p^2 = .06$ , were observed.

**Error rates.** Mean error rates for each trial condition are reported in Table 3. Again, these values were submitted to a 2 x 3 repeated measures ANOVA with Element (boundaries: meridian crossing, meridian non-crossing) and Trial Condition (invalid-horizontal, and invalid-vertical, and valid) as within-subjects factors. There were no significant main effects or interactions, all  $F$ s < 2, all  $p$ s > .2, nor any significant pairwise comparisons, all  $t$ s < 2, all  $p$ s > .05, indicating no statistically significant differences in error rates across trial conditions.

## **Discussion**

In agreement with our previous results, disparities between RTs to detect targets at invalid-horizontal and invalid-vertical locations were observed when target locations necessitated shifts of attention across the visual field meridians, regardless of object boundary placement. As observed in Experiment 2, a horizontal advantage SDA emerged when targets appeared within object boundaries, whereas a vertical advantage SDA emerged when targets appeared outside object boundaries. We suggest two explanations to account for this vertical advantage SDA. First, participants must disengage from object-based selection and re-engage a non-object-based mode of selection due to weakened integration of the targets and object. Second, the balance between enhancing and suppressing attentional resources favors the horizontal advantage SDA for targets inside the object and the vertical advantage SDA for targets outside the object (see Experiment 2 Discussion). There were no significant differences between horizontal and vertical shifts of attention when target locations did not cross the visual field meridians, regardless of object placement.

These findings support our hypotheses that the SDA emerges when invalid target locations, independent of the placement of object boundaries, necessitate shifts of attention across the meridians, and does not emerge when target locations do not necessitate a shift across

the meridians. Taken together, the results from Experiments 1-3B suggest that the boundaries of an object in relation to the visual field meridians are not a contributing factor in the emergence of the SDA.

### **Aggregated Analyses**

While the results of each individual experiment stand on their own, we aggregated the data from the current experiments to examine whether the SDA occurs only under conditions of meridian crossings. We compared the magnitudes of the SDAs among each object-target configuration across Experiments 1-3B. Four separate univariate ANOVAs (one for each configuration) confirmed there were no significant differences in SDA magnitude across experiments, all  $F_s < 3$ , all  $p_s > .1$ ; therefore, we collapsed across experiment and calculated a mean SDA magnitude for each configuration. The results of one-sample  $t$ -tests revealed a significant horizontal advantage SDA for the Crossing Object and Targets configuration ( $M = 52.76$  ms,  $SEM = 8.34$  ms),  $t(83) = 6.32$ ,  $p < .001$ , and a significant vertical advantage SDA for the Non-crossing Object, Crossing Targets configuration ( $M = 53.05$  ms,  $SEM = 9.29$  ms),  $t(57) = 5.71$ ,  $p < .001$ . The JZS Bayes Factor values for these two configurations ( $> 30$ ) provided overwhelmingly strong support in favor of the alternative hypothesis. The SDAs for the Non-crossing Object and Targets configuration ( $M = 15.66$  ms,  $SEM = 11.85$  ms) and the Crossing Object, Non-crossing Targets configuration ( $M = 8.38$  ms,  $SEM = 7.99$  ms) were not significant, all  $t_s < 2$ , all  $p_s > .1$ , with JZS Bayes Factor values favoring the null hypothesis.

### **Experiments 4: Cue-to-target distance control**

In Experiments 1-3B, we investigated the contributions of invalid target location and placement of object boundaries in relation to the visual field meridians on the SDA. The SDA emerged only when invalid target locations necessitated shifts of attention that crossed the

meridians, regardless of object boundary placement. The anisotropy appears, thus, to be driven by target location (rather than the placement of object boundaries) relative to the visual field meridians. However, the cue-to-target distance varied systematically in all the experiments that involved the manipulation of the invalid target location. For instance, the cue-to-target separation was over 3 degrees of visual angle larger in the crossing condition than in the non-crossing condition. In order to substantiate our conclusion that the SDA is driven by the location of the invalid targets, Experiment 4 was conducted to show that the manifestation of the SDA depends on the target crossing the meridians while maintaining a fixed distance between the cue and target. We predicted that a significant SDA would emerge when the invalid target locations crossed the meridians and that no SDA would emerge when the invalid target locations did not cross the meridians.

## **Method**

All aspects of Experiment 4 were identical to those of Experiment 1, except as described below.

**Participants.** Thirty-one new individuals from the University of Wisconsin-Milwaukee and surrounding community ( $M_{\text{age}} = 23.00$  years,  $SD_{\text{age}} = 6.43$  years; 20 women, 11 men) participated in this experiment.

**Apparatus, stimuli, design, and procedure.** On all trials, the ‘L’-shaped object was composed of a  $2.0^\circ \times 10.65^\circ$  vertical component rectangle conjoined at a 90-degree angle with a  $10.65^\circ \times 2.0^\circ$  horizontal component rectangle. The cue-to-target separation for the crossing and the non-crossing ‘L’-shaped objects was maintained at a fixed distance. The crossing ‘L’-shaped object was placed such that its nearest edge was  $2.67^\circ$  above or below the horizontal meridian and  $2.67^\circ$  to the left or right of the vertical meridian, and situated on the screen such that the

distance from the vertical screen meridian to the inner edge of the vertical component rectangle matched the distance from the horizontal screen meridian to the inner edge of the horizontal component rectangle, both being  $6.00^\circ$ . The non-crossing 'L'-shaped object was placed such that its nearest edge was  $0.67^\circ$  above or below the horizontal meridian and  $0.67^\circ$  to the left or right of the vertical meridian, and situated on the screen such that the distance from the vertical screen meridian to the inner edge of the vertical component rectangle matched the distance from the horizontal screen meridian to the inner edge of the horizontal component rectangle, both being  $9.33^\circ$ . Crossing and non-crossing conditions were randomly intermixed within blocks and were equally likely to appear on any given trial.

## Results

**Data quality.** The original sample of 31 participants had a mean false alarm rate of 8% ( $SD = 8\%$ ) and a mean miss rate of 3% ( $SD = 4\%$ ). Three participants with an excessively high false alarm rate ( $n = 2$ ;  $M = 31\%$ ,  $SD = 6\%$ ) on catch trials and/or miss rate ( $n = 1$ ;  $N = 125$  trials) on target-present trials were discarded. This resulted in a final sample of 28 participants ( $M_{age} = 23.29$  years,  $SD_{age} = 6.72$  years; 19 women, 9 men) with a mean false alarm rate of 6% ( $SD = 5\%$ ) and a mean miss rate of 2% ( $SD = 2\%$ ). Independent samples  $t$ -tests revealed a marginally larger false alarm rate for the excluded participants compared to the included participants,  $t(1.10) = 6.55$ ,  $p = .080$ ,  $d = 5.14$ . As in Experiment 1, anticipatory responses (RT less than 200 ms) were discarded.

**Response latencies.** The dependent variable was mean RT for correct responses, reported in Table 4. As in Experiment 1, mean RT differences were calculated by subtracting mean raw RTs to valid targets from mean RTs to invalid-horizontal targets and invalid-vertical targets. Next, mean RT differences were submitted to a 2 x 2 repeated measures ANOVA with Element

Table 4. Mean raw RTs (ms) for correct responses in Experiments 4 and 5.

	Trial Condition			
	Invalid- horizontal	Invalid- vertical	Valid	SDA
Experiment 4				
Crossing object and targets	694.18 (8.23)	726.55 (6.16)	500.88 (8.19)	<b>32.37</b> <b>(19.60)</b>
Non-crossing object, crossing targets	701.89 (9.62)	724.32 (6.03)	518.22 (16.51)	22.43 (14.52)
Experiment 5				
Spatial Attention Control	915.29 (7.81)	930.14 (5.77)	633.43 (9.40)	14.85 (31.50)

*Note.* Across all experiments, there were significant space-based cueing effects such that valid RTs were significantly faster than invalid RTs, all  $ps < .001$ . SDA = invalid-vertical RTs minus invalid-horizontal RTs. Significant SDAs are bolded. Values in parentheses are *SEMs*.

(boundaries and targets: meridian crossing, meridian non-crossing) and Shift Direction (horizontal, vertical) as within-subjects factors. The analysis revealed a marginal main effect of Element,  $F(1,27) = 3.37, p = .078, \eta_p^2 = .11$ , indicating a marginally-significant difference in invalid target detection RT when reallocating object-based attention when both the object boundaries and invalid target locations crossed the meridians ( $M = 209.48$  ms,  $SEM = 12.29$  ms) versus when both the object boundaries and invalid target locations did not cross the meridians ( $M = 194.88$  ms,  $SEM = 16.18$  ms). Furthermore, the analysis revealed a main effect of Shift Direction,  $F(1,27) = 7.91, p = .009, \eta_p^2 = .23$ , indicating a significant difference in invalid target detection RT when reallocating object-based attention horizontally ( $M = 188.48$  ms,  $SEM = 14.13$  ms) versus vertically ( $M = 215.88$  ms,  $SEM = 15.12$  ms). The interaction did not reach significance,  $F(1,27) = 0.45, p = .508, \eta_p^2 = .02$ .

For crossing ‘L’-shaped objects and invalid target locations that necessitated shifts of attention across the meridians, a paired samples *t*-test revealed a significant SDA, such that reallocating object-based attention horizontally ( $M = 193.30$  ms,  $SEM = 6.00$  ms) was

significantly faster than reallocating vertically ( $M = 225.67$  ms,  $SEM = 6.00$  ms),  $t(27) = 2.70$ ,  $p = .012$ ,  $d = 0.45$ . However, for non-crossing 'L'-shaped objects and invalid target locations that did not necessitate shifts of object-based attention across the meridians, a paired samples  $t$ -test revealed no SDA, such that horizontal shifts of attention ( $M = 183.66$  ms,  $SEM = 6.23$  ms) were statistically equivalent to vertical shifts of attention ( $M = 206.09$ ,  $SEM = 6.23$  ms),  $t(27) = 1.80$ ,  $p = .083$ ,  $d = 0.24$  (See Fig. 12). The JZS Bayes Factor was 1.21 in favor of the null hypothesis. Thus, when controlling for the cue-to-target distance, there was a significantly larger SDA when both the object boundaries and invalid target locations crossed the meridians (32.37 ms) versus when they did not cross the meridians (22.43 ms).

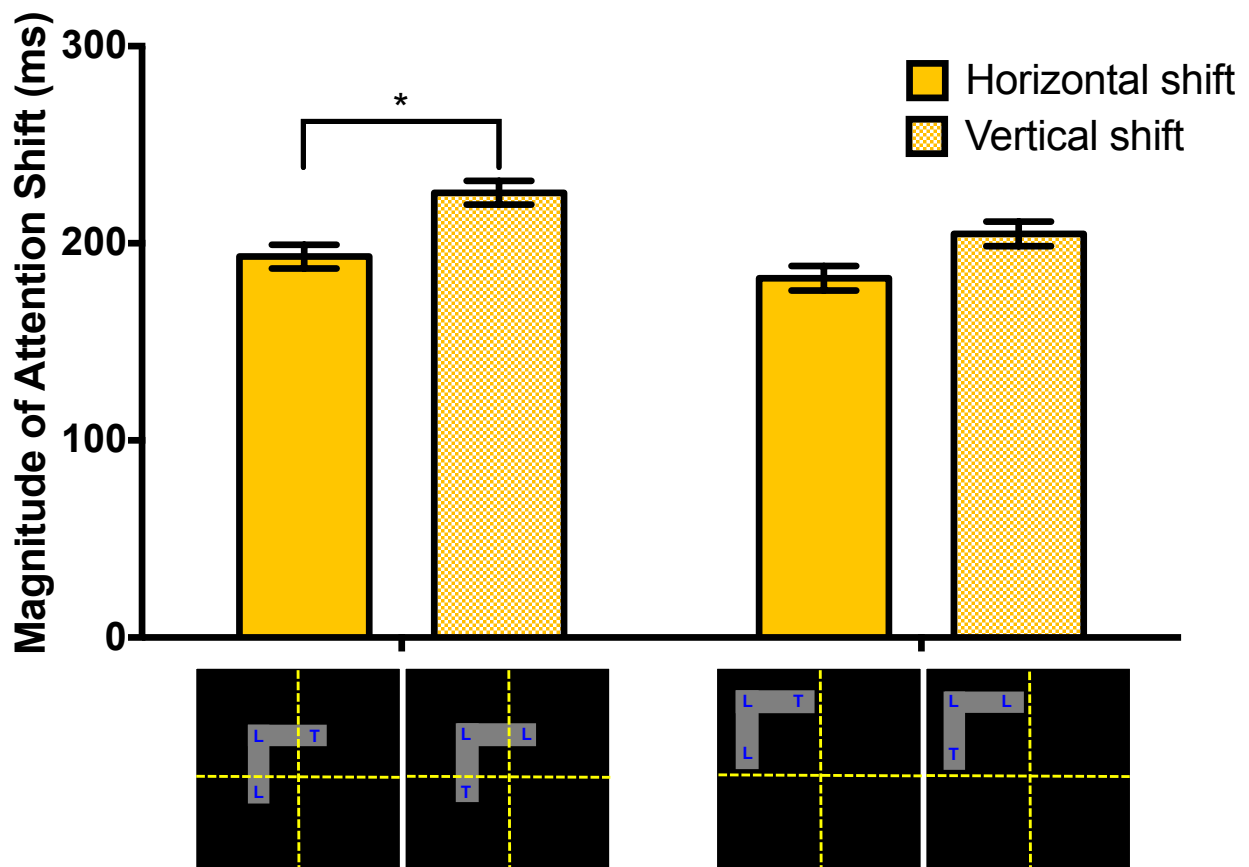

**Figure 12. Mean response latencies in Experiment 4 (Cue-to-target distance control).** “Magnitude of Attention Shift” measured for the Element (Boundaries and Targets) x Shift Direction interaction in Experiment 4. The error bars represent the standard error of the mean for within-subjects design.

When all 31 participants were included, we observed a similar main effect of Shift Direction,  $F(1,30) = 9.46$ ,  $p = .004$ ,  $\eta_p^2 = .24$ . Neither the main effect of Element,  $F(1,30) = 1.77$ ,  $p = .193$ ,  $\eta_p^2 = .06$ , nor the two-way interaction,  $F(1,30) = 0.04$ ,  $p = .840$ ,  $\eta_p^2 = .00$ , were observed.

**Error rates.** Mean error rates for each trial condition are reported in Table 5. These values were submitted to a 2 x 3 repeated measures ANOVA with Element (boundaries and targets: meridian crossing, meridian non-crossing) and Trial Condition (invalid-horizontal, and invalid-vertical, and valid) as within-subjects factors. There were no significant main effects or interactions, all  $F$ s < 2, all  $p$ s > .2, nor any significant pairwise comparisons, all  $t$ s < 2, all  $p$ s > .1, indicating no statistically significant differences in error rates across trial conditions.

Table 5. Mean error rates (percent of misses) in Experiments 4 and 5.

	Trial Condition		
	Invalid- horizontal	Invalid- vertical	Valid
Experiment 4			
Crossing object and targets	2.31 (0.53)	2.23 (0.49)	2.13 (0.40)
Non-crossing object and targets	3.05 (0.73)	2.60 (0.68)	2.37 (0.42)
Experiment 5			
Spatial Attention Control	3.63 (0.79)	2.26 (0.44)	2.62 (0.48)

*Note.* Values in parentheses are *SEMs*

## Discussion

In this first control experiment, we were able to replicate the general pattern of results while controlling for the cue-to-target distance. We observed a significant SDA when the object boundaries and invalid target locations crossed the meridians and failed to observe an SDA when the object boundaries and invalid target locations did not cross the meridians. This result further

strengthens our overall conclusion – that the SDA is driven by target location, not object placement.

### **Experiment 5: Spatial attention control**

The paradigm that we utilized in the above experiments differs from more “traditional” object-based attention paradigms in two ways. First, we were only interested in measuring the asymmetry between horizontal and vertical shifts of object-based attention (without the confound of shifting between objects) as opposed to the same object advantage that is typically measured in object-based attention paradigms. Second, we presented participants with only one object, rather than two objects, making it possible that few object-based attentional resources were necessary to perform the task. We previously demonstrated, however, that the SDA emerged when competition for object-based attentional selection was low (such as with only a single ‘L’-shaped object) as well as when competition for object-based attentional selection was high (such as with both cued and non-cued ‘L’-shaped objects; Barnas & Greenberg, 2016). Nevertheless, one might question whether the performance differences observed in the above experiments arise truly as a result of object-based attention. In order to address this issue, we performed a second control experiment in which the ‘L’-shaped object was removed entirely from the paradigm, allowing us to determine whether or not the SDA is an effect of object-based attentional selection, at all. If we observe the SDA in the absence of the ‘L’-shaped object, then we can infer that the performance difference between horizontal and vertical shifts of attention is caused (at least, partially) by something other than object-based attention (since only spatial attention mechanisms should be engaged in this experiment). Conversely, if we fail to observe an SDA in the absence of the ‘L’-shaped object, then we can infer that the performance difference between horizontal and vertical shifts depends on object-based attention.

## Method

All aspects of Experiment 5 were identical to those of Experiment 1, except as described below.

**Participants.** Thirty-one new individuals from the University of Wisconsin-Milwaukee and surrounding community ( $M_{age} = 20.35$  years,  $SD_{age} = 2.07$  years; 27 women, 4 men) participated in this experiment.

**Apparatus, stimuli, design, and procedure.** The ‘L’-shaped object was not presented during this experiment. On all trials, target and non-target letters were positioned so that their centers were  $1.67^\circ$  above or below the horizontal meridian and  $1.67^\circ$  to the left or to the right of the vertical meridian, depending on the location of cue (See Fig. 13). Invalid-horizontal and invalid-vertical targets were equidistant from the peripheral cue.

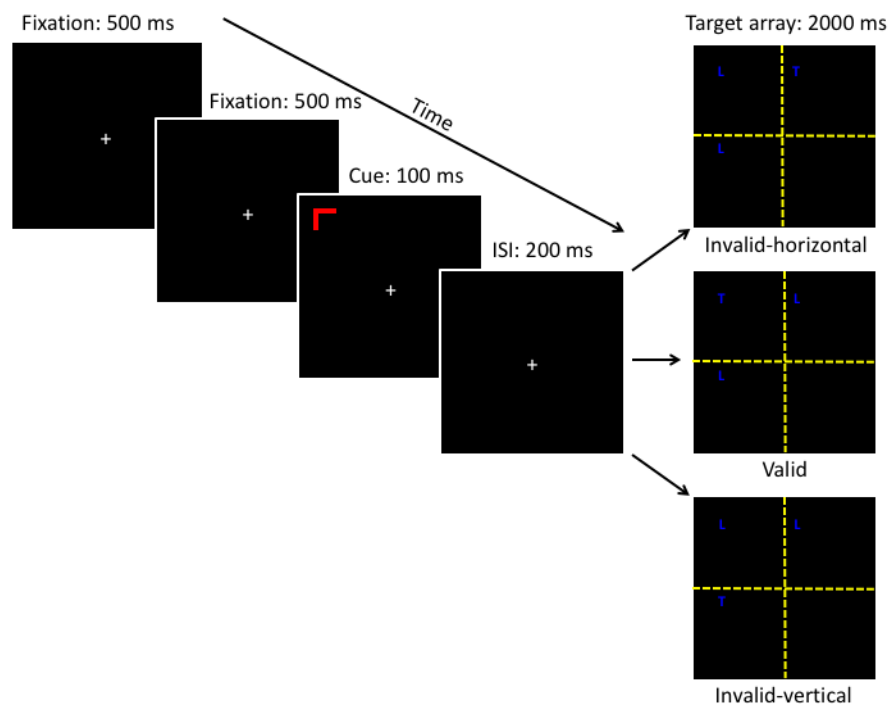

**Figure 13. Trial sequence for Experiment 5 (Spatial Attention Control).** Invalid target locations cross the visual field meridians with no object present. Trial conditions were defined by the location of the blue target ‘T’ in relation to the red peripheral cue in the upper-left quadrant. *Note:* Locations of invalid targets in relation to the visual field meridians are not drawn to scale; dotted yellow lines represent the horizontal and vertical meridians and were not visible to participants during the experiment.

## Results

**Data Quality.** The original sample of 31 participants had a mean false alarm rate of 10% ( $SD = 14\%$ ) and a mean miss rate of 3% ( $SD = 4\%$ ). Using the same exclusion criteria from Experiment 1, a total of 2 participants with an excessively high false alarm rate ( $n = 2$ ;  $M = 54\%$ ,  $SD = 29\%$ ) on catch trials and/or number of misses ( $N = 150$  trials) on target-present trials were discarded. This resulted in a final sample of 29 participants ( $M_{\text{age}} = 20.10$  years,  $SD_{\text{age}} = 1.82$  years; 26 women, 3 men) with a mean false alarm rate of 7% ( $SD = 6\%$ ) and a mean miss rate of 3% ( $SD = 3\%$ ). An independent samples  $t$ -test revealed no difference in the false alarm rates between the excluded and included participants,  $t(1.01) = 2.29$ ,  $p = .261$ ,  $d = 2.25$ . Additionally, anticipatory responses (RT less than 200 ms) were discarded.

**Response latencies.** The dependent variable was the mean RT for correct responses, reported in Table 4. Mean RT differences were calculated by subtracting the mean raw RT to valid targets from mean RTs to targets in the invalid-horizontal location and invalid-vertical location. Next, mean RT differences were submitted to a within-subjects, repeated measures ANOVA with Shift Direction (horizontal, vertical) as a single factor. The effect of Shift Direction was not significant,  $F(1,28) = 2.20$ ,  $p = .149$ ,  $\eta_p^2 = .07$ , indicating that detection RTs for invalid-horizontal targets ( $M = 281.87$  ms,  $SEM = 15.39$  ms) were statistically equivalent to detection RTs for invalid-vertical targets ( $M = 296.71$  ms,  $SEM = 15.79$  ms; See Fig. 14). The JZS Bayes Factor was 1.90, in favor of the null hypothesis.

**Between-experiment analysis.** To further bolster our claim that the SDA is an effect specific to object-based selection, we conducted a between-experiment analysis using these data and aggregated data from the crossing object and targets configuration (See Aggregated Analyses) to examine the interaction between object presence and shift direction. The main

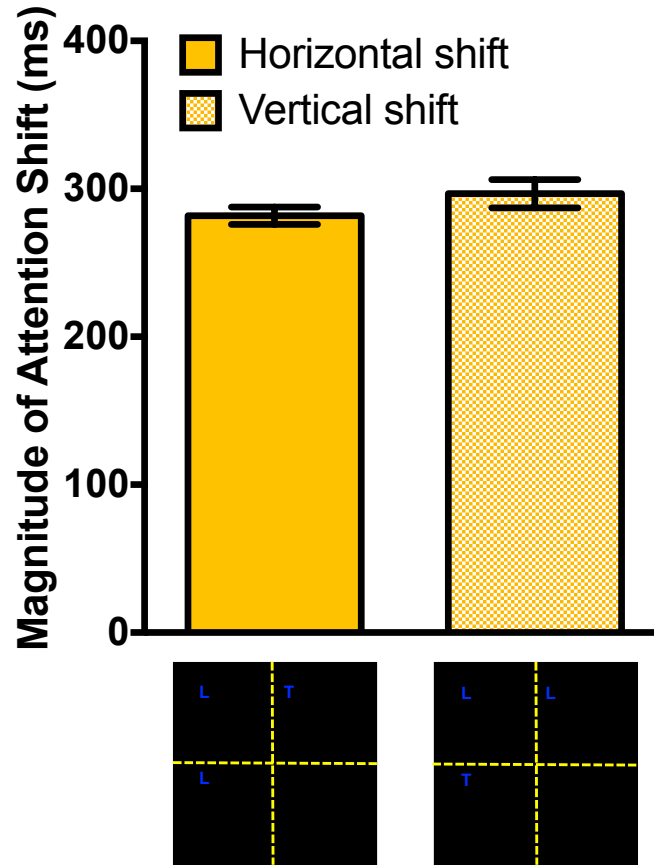

**Figure 14. Mean response latencies in Experiment 5.** “Magnitude of Attention Shift” measured for the Shift Direction effect in Experiment 5. The error bars represent the standard error of the mean for within-subjects design.

difference between these two experiments was object presence – the object was present in the aggregated data and absent in the spatial control data. Mean RT differences were submitted to a 2 x 2 repeated measures ANOVA with Shift Direction (horizontal, vertical) as a within-subjects factor and Object Presence (present, absent) as a between-subjects factor. The analysis revealed a significant two-way interaction,  $F(1,111) = 6.07, p < .015, \eta_p^2 = .05$ , indicating that the magnitude of the SDA varied as a function of whether the object was present (52.76 ms) or absent (14.85 ms).

**Error rates.** Mean error rates for each trial condition are reported in Table 5. These values were submitted to a within-subjects, repeated measures ANOVA with Trial Condition (valid, invalid-horizontal, invalid-vertical) as a single factor. Results revealed a significant effect of Trial Condition,  $F(2,56) = 4.28, p = .019, \eta_p^2 = .13$ . Pairwise comparisons revealed a significantly greater error rate for invalid-horizontal trials compared to invalid-vertical trials,  $t(28) = 2.42, p = .022, d = 0.40$ . However, correlating error rates and RTs for each trial condition revealed significant, positive correlations, all  $r_s > .4$ , all  $p_s < .02$ , revealing the absence of a speed-accuracy trade-off.

## **Discussion**

In this control experiment, in the absence of an object percept, we failed to observe an SDA. This result, coupled with our findings from the previous experiments herein, suggests that the SDA observed in the presence of an object percept is dependent on an object-based mode of attentional selection and cannot simply be explained by spatial selective attention.

Nevertheless, some studies have observed anisotropic shifts of attention without the presence of objects. For instance, Pauszek and Gibson (2016) used a search task in which letters could appear along one of the four cardinal axes. When participants were cued with endogenous, informative spatial words at central fixation, the researchers observed faster performance when the target appeared on the horizontal meridian than when it appeared on the vertical meridian. A number of differences between the present experiment and the study reported by Pauszek and Gibson (2016) could account for the observed discrepancy (e.g., cue-type and target locations). Importantly, though, the present experiment replicates at least one published report showing no direction-based differences in a similar spatial attention paradigm (Henderson & Macquistan, 1993). Similar to our experiment, Henderson and Macquistan (1993; Experiment 3) utilized

target locations that were displayed at the corners of an imaginary square centered around a central fixation cross and arranged so that one location appeared in each visual field quadrant. When participants were exogenously cued to a possible target location, they were equally fast reallocating attention horizontally and vertically.

### **General Discussion**

Previous research using the double rectangle cueing paradigm (Egly, Driver, & Rafal, 1994) has shown that the preferential processing of visual information as a result of object-based attentional selection can differ with the orientation of the two rectangles. A same object advantage (i.e., faster RTs to invalid target locations on a cued object versus a non-cued object) is frequently reported for horizontal objects, whereas a same object cost (i.e., slower RTs to invalid locations on a cued object versus a non-cued object) has been reported for vertical objects (Al-Janabi & Greenberg, 2016; Conci & Müller, 2009; Harrison & Feldman, 2009; Hein, Blaschke, & Rolke, 2016; Pilz, Roggeveen, Creighton, Bennet, & Sekular, 2012). Our work previously investigated this dissociation by comparing the reallocation of object-based attention across the horizontal versus vertical meridian using a single 'L'-shaped object (Barnas & Greenberg, 2016). We observed a shift direction anisotropy (SDA), in that shifts of object-based attention within a cued object were more efficient across the vertical meridian (a horizontal shift advantage) suggesting that an object's position within the visual field may be an important factor in the emergence of the horizontal advantage SDA.

In this chapter, we asked whether the disparity between horizontal and vertical shifts of object-based attention caused by the visual field meridians depends upon the placement of the object boundaries, locations of the invalid targets, or both. This was accomplished by juxtaposing meridian crossings of object boundaries and invalid target locations while measuring

the anisotropy between horizontal and vertical shifts of attention. The results of Experiments 1-3B are summarized in Figure 15.

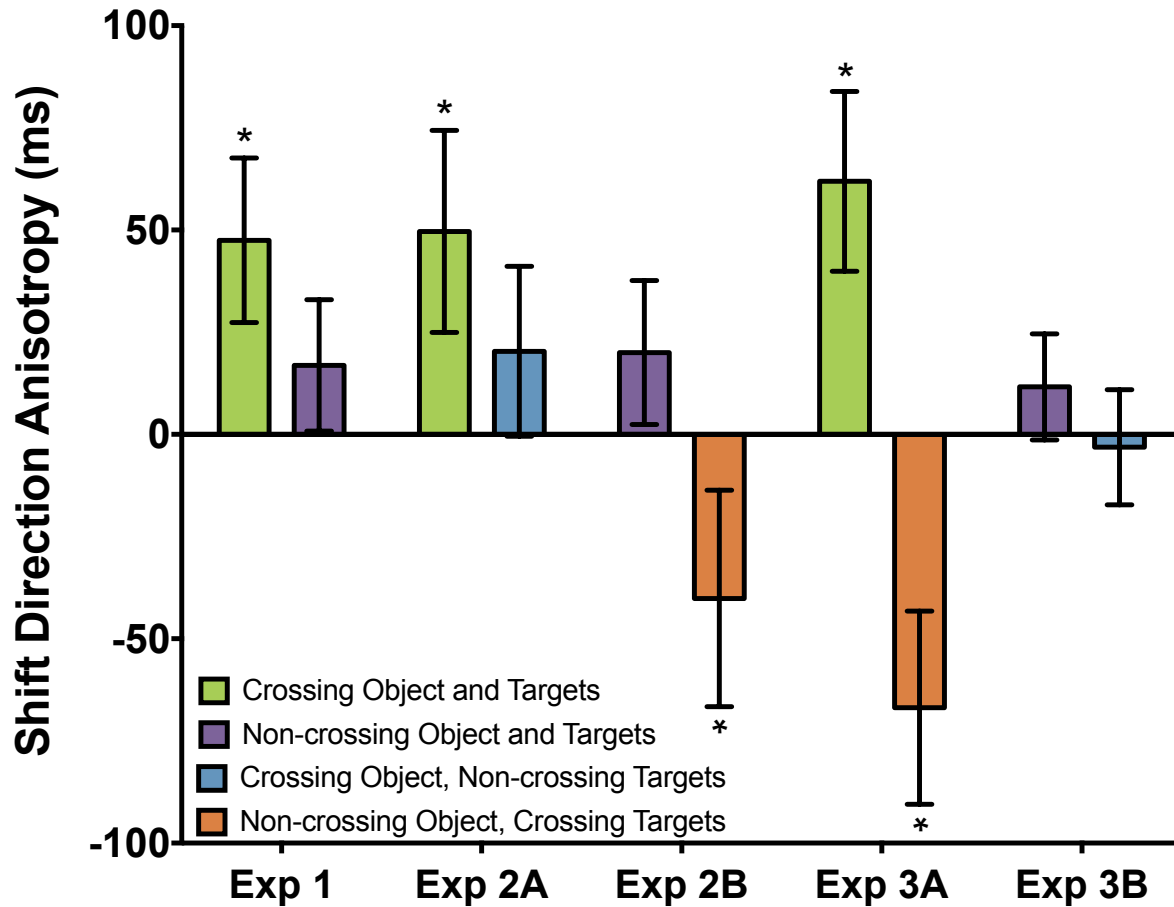

**Figure 15. Shift direction anisotropies across Experiments 1-3B.** Shift direction anisotropies were calculated by subtracting RT difference for invalid-horizontal target location from RT difference for invalid vertical target location. Positive values indicate a horizontal shift advantage (invalid-horizontal RT < invalid-vertical RT), whereas negative values indicate a vertical shift advantage (invalid-vertical RT < invalid-horizontal RT). The error bars represent the standard error of the mean for within-subjects designs. Asterisks indicate significant shift direction anisotropies (significant difference from zero; all  $ps \leq .008$ )

In Experiment 1, we replicated our previous results (Barnas & Greenberg, 2016): the SDA emerged when both the object boundaries and invalid target locations crossed the meridians but not when object boundaries and invalid target locations did not cross the meridians. In

Experiments 2A and 2B, we held constant the placement of object boundaries which allowed us to assess the role of the invalid target locations on the SDA. When invalid target locations crossed the meridians, we observed a significant SDA; when target locations did not cross the meridians, we did not observe the SDA. Thus, when target locations necessitate a shift of attention that crosses the meridians, the anisotropy emerges, regardless of whether or not the object boundaries cross the meridians. To further explore the role of object boundaries on the SDA, in Experiments 3A and 3B we held constant the invalid target locations. Again, we found that when target locations required a shift across the meridians, we observed the SDA; and that when targets did not evoke a shift across the meridians, we did not observe the SDA. Importantly, as in Experiment 2, the locations of object boundaries (extending across the meridians or not) did not seem to play a role in the SDA.

Two control experiments were conducted to further substantiate the results from Experiments 1-3B. The results of these control experiments (Experiments 4 and 5) are summarized in Figure 16. In Experiment 4, cue-to-target distance was held constant in order to demonstrate that the SDA depends purely on meridian crossings of targets. The SDA emerged only when target locations crossed the meridians and did not emerge when targets did not cross the meridians, indicating that the systematic variation of cue-to-target distance did not influence the manifestation of the SDA. In Experiment 5, the object was removed from the stimulus in order to determine whether or not the SDA is, explicitly, a characteristic of object-based attentional selection. We observed no SDA in the absence of an object, suggesting that the SDA is specific to object-based attentional selection.

Notably, Experiments 2B & 3A contained a condition during which the target was not located within object boundaries; in both cases, the target location crossed the meridians, but the

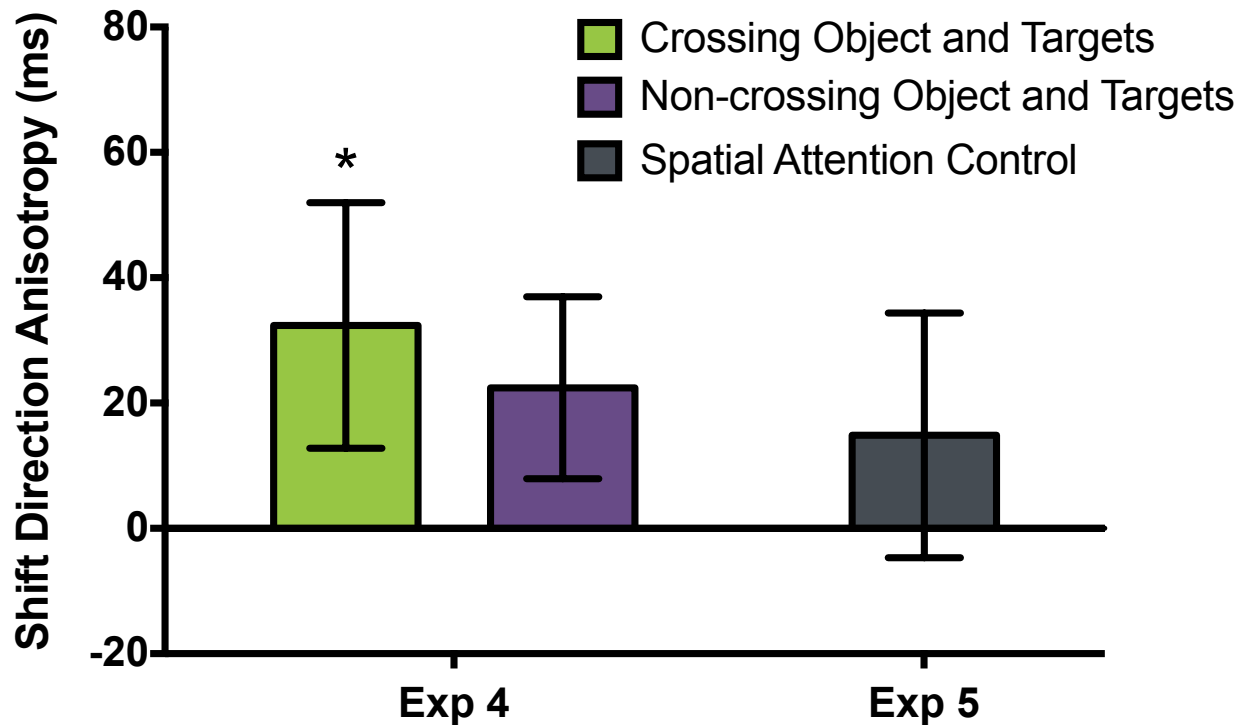

**Figure 16. Shift direction anisotropies across Experiments 4 and 5.** Shift direction anisotropies were calculated by subtracting RT difference for invalid-horizontal target location from RT difference for invalid vertical target location. Positive values indicate a horizontal shift advantage (invalid-horizontal RT < invalid-vertical RT), whereas negative values indicate a vertical shift advantage (invalid-vertical RT < invalid-horizontal RT). The error bars represent the standard error of the mean for within-subjects designs. Asterisk indicates significant shift direction anisotropy (significant difference from zero;  $p = .012$ )

object boundaries did not. Commensurate with target location driving the SDA, we observed significant anisotropies between horizontal and vertical shifts, however the sign of these effects was reversed (i.e., a vertical advantage SDA). This provides additional evidence that target-object integration also plays a modulatory role in object-based attention, as we've previously reported (Al-Janabi & Greenberg, 2016). Furthermore, the vertical advantage SDA may emerge for targets outside the boundaries of the object due to a weaker suppression of attentional resources in the invalid-vertical location compared to the invalid-horizontal location (which results from the complementary enhancement of attentional resources within the object at the

invalid-horizontal location compared to invalid-vertical location). In summary, these findings demonstrate that the SDA is (1) driven by target locations that require a shift of attention across the visual field meridians, (2) a phenomenon of object-based attentional selection (and not a more general measure observable when selection is not object-based), and (3) affected by target-object integration and the simultaneous enhancement and suppression of attentional resources at locations inside the object relative to locations outside the object.

The pattern of performance we observed for targets within the boundaries of an object is consistent with the attentional prioritization hypothesis of object-based attentional selection as opposed to, for instance, the sensory enhancement (or, attentional spreading) hypothesis. The former theory proposes that object-based attentional prioritization is distributed to behaviorally relevant (e.g., target) locations within an object and not simply spread equally throughout all locations on that object (Shomstein & Behrmann, 2008; Shomstein & Yantis, 2002, 2004). The latter theory proposes an automatic spread of OBA resources within an attended object, such that all target locations within an object are afforded an enhancement of attentional processing (Chen & Cave, 2006, 2008; Richards, Lee, & Vecera, 2008). Consider, for instance, Experiment 2A in which the object always crossed the meridians and the target locations varied. Here, we observed an effect of object-based attention (the SDA) that was modulated by target locations (the SDA emerged only when target locations required a shift of attention across the meridians), suggesting that prioritization of attention was unequally distributed across crossing and non-crossing target locations and that target locations were not afforded equal enhancement. Thus, object-based attention seems to prioritize *specific* target locations and not simply *all* locations within a cued object.

## **CHAPTER 4: Is the Shift Direction Anisotropy Susceptible to Manipulations of the Visual Field Meridians?**

Our goal here was to test the causal role of the meridians by manipulating their local feature contrast (or, perceptual visibility) to determine whether the shift direction anisotropy is susceptible to perceptual manipulations of the visual field meridians. Specifically, we are interested in learning whether there are circumstances in which the SDA can be attenuated or eliminated altogether, and whether modulations of the SDA occur as a result of emphasizing the horizontal meridian, vertical meridian, or both. Five experiments were conducted in which horizontal and vertical meridian perceptual visibility was emphasized with different manipulations of the local feature contrast (See Fig. 17). High local feature contrast manipulations included white visible lines (Experiment 6), visible lines of varying contrasts (Experiment 7), and different colored background hemifields (Experiment 8). Low local feature contrast manipulations included illusory contours (Experiment 9) and increasing the visibility of the ends of the meridians (Experiment 10). Similar to Experiments 1-5, we measured RTs to detect a visual stimulus at invalid-vertical and invalid-horizontal target locations and calculated the RT difference to derive the SDA. Modulations of the SDA as a result of emphasizing the perceptual visibility of the meridians would causally implicate one or both of the meridians in the emergence of the SDA, suggesting that the SDA is malleable and may be eliminated under certain circumstances.

### **Experiment 6: High local feature contrast manipulation with a visible line**

The goal of Experiment 6 was to observe whether a high local feature contrast manipulation, such as placing white visible lines on the meridians, modulates the magnitude of

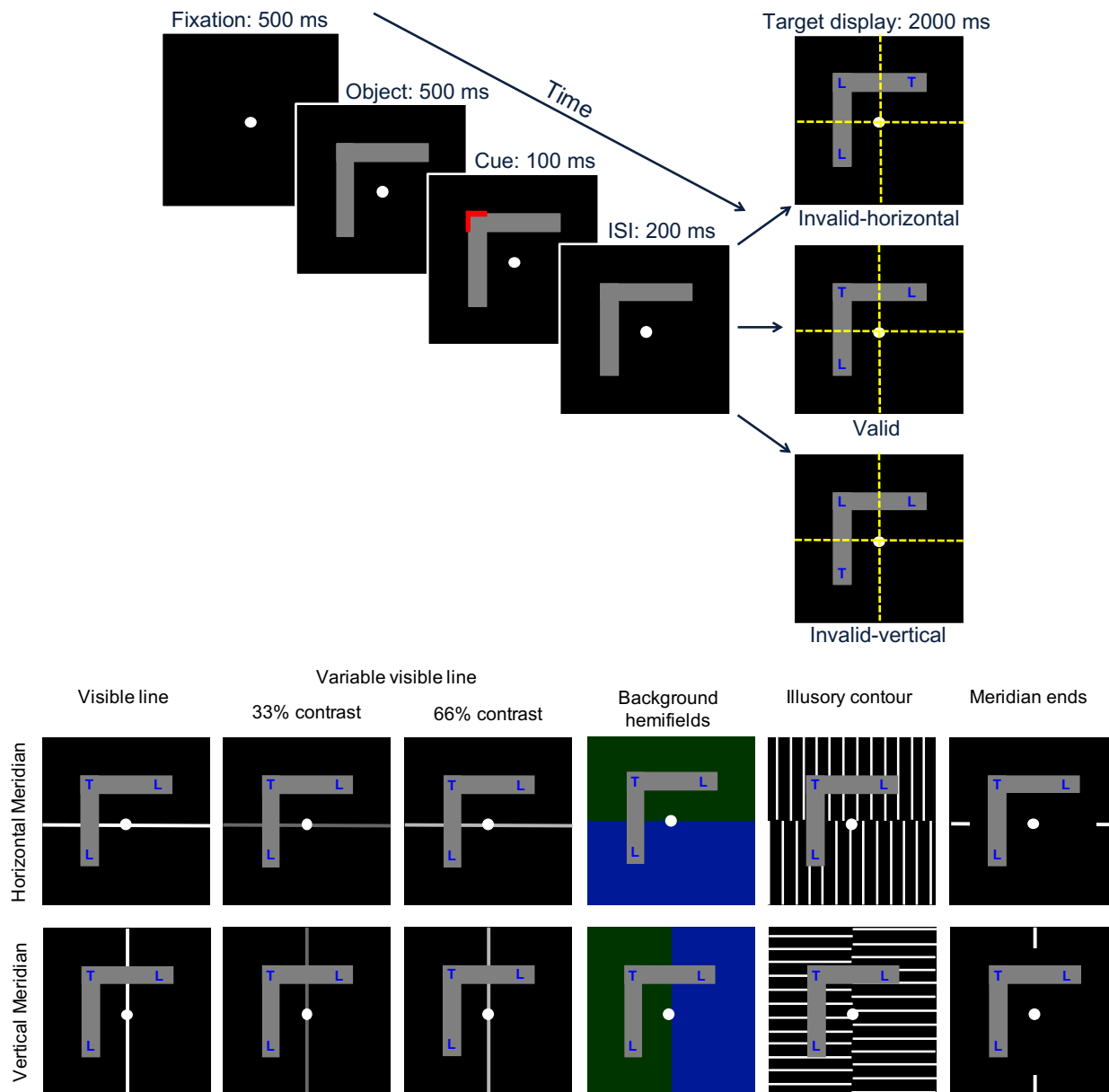

**Figure 17. Trial sequence and meridian manipulations for Experiments 6-10. (Top)** Trial sequence for no meridian baseline control. Trial conditions were defined by the location of the blue target ‘T’ in relation to the red peripheral cue at the object vertex. **(Bottom)** Meridian manipulations for “Visible Line” (Experiment 6), “Variable visible line” (Experiment 7), “Background hemifields” (Experiment 8), “Illusory contour” (Experiment 9), and “Meridian ends” (Experiment 10).

*Note:* Dotted yellow lines represent the horizontal and vertical meridians and were not visible to participants during the experiment; trial sequence was the same for each meridian condition. For Variable Visible Line, only 33% and 66% contrasts displayed, but 0% contrast (no meridian) and 100% contrast were also included. For Background Hemifields, it was equally likely to have blue upper and green lower or blue left and green right. No meridian condition consisted of only green or blue. Not drawn to scale.

the SDA. We hypothesized that increasing the local feature contrast of the vertical meridian would have no effect on the SDA given the naturally occurring interhemispheric boundary between left and right cortical hemispheres (Holtzman, Sidtis, Volpe, Wilson, & Gazzaniga, 1982; Reuter-Lorenz & Fendrich, 1992a). Conversely, we believed that increasing the local feature contrast of the horizontal meridian would modulate the SDA by strengthening the intrahemispheric boundary between upper and lower visual hemifields.

## **Method**

Here, we continued to use the ‘L’-shaped object stimuli introduced by Barnas & Greenberg (2016). All aspects of Experiment 6 were identical to those of Experiment 1, except as described below.

**Participants.** Thirty-two new individuals from the University of Wisconsin-Milwaukee and surrounding community ( $M_{\text{age}} = 22.19$  years,  $SD_{\text{age}} = 6.86$  years; 23 women, 8 men) participated in this experiment.

**Apparatus, stimuli, design, and procedure.** As shown in Figure 17, the ‘L’-shaped object consisted of a vertical rectangle ( $2.0^\circ \times 12.0^\circ$ ) joined with a horizontal rectangle ( $12.0^\circ \times 2.0^\circ$ ) on a black background. While participants fixated centrally on a white fixation circle ( $0.50^\circ$  in diameter), the object vertex was randomly positioned in one screen quadrant such that one object component always crossed the vertical meridian and the other component always crossed the horizontal meridian. The ‘L’-shaped object was centered on the screen and around the central fixation circle, such that the distances between the vertical screen meridian to the inner edge of the vertical component rectangle and between the horizontal screen meridian to the inner edge of the horizontal component rectangle were both  $4.0^\circ$ . Target letters were positioned so that their centers were always  $1.0^\circ$  from the near end of the object.

Visual field meridians were emphasized with a visible line at 100% contrast that was centered on the horizontal meridian ( $48.48^\circ \times 0.17^\circ$ ) or the vertical meridian ( $0.17^\circ \times 48.48^\circ$ ). A no meridian enhancement condition served as a baseline control. There were 8 blocks of trials, each containing 120 trials for a total of 960 trials. Horizontal and vertical meridian conditions were randomly intermixed within blocks, along with the baseline control. That is, participants were equally likely to get a visible horizontal meridian, visible vertical meridian, or no meridian enhancement on any given trial.

Each block consisted of 60% valid trials (72 trials per block; 576 total), 10% invalid-horizontal trials (12 trials per block; 96 total), and 10% invalid-vertical trials (12 trials per block; 96 total). To ensure selective responding, the remaining trials were composed of “catch trials” (20%; 24 trials per block; 192 total) in which only non-target letters appeared on the object. These proportions were split evenly between the three meridian conditions, such that each meridian condition was allotted an equivalent number of trials (e.g., 4 invalid-horizontal trials per block for the horizontal meridian, vertical meridian, and no meridian baseline, or a total of 32 invalid-horizontal trials per meridian condition).

## Results

**Data quality.** The original sample of 32 participants had a mean false alarm rate of 10% ( $SD = 9\%$ ) and a mean miss rate of 2% ( $SD = 2\%$ ). Using the same exclusion criteria from Experiment 1, a total of 4 participants with an excessively high false alarm rate ( $M = 31\%$ ,  $SD = 3\%$ ) on catch trials were discarded. This resulted in a final sample of 28 participants ( $M_{age} = 22.61$  years,  $SD_{age} = 7.10$  years; 20 women, 8 men) with a mean false alarm rate of 8% ( $SD = 6\%$ ) and a mean miss rate of 2% ( $SD = 2\%$ ). An independent samples  $t$ -test revealed a significantly larger false alarm rate for the excluded participants compared to the included

participants,  $t(5.25) = 8.16, p < .001, d = 3.09$ . Additionally, anticipatory responses (RT less than 200 ms) were discarded.

Table 6. Mean raw RTs (ms) for correct responses in Experiments 6-10, by meridian enhancement condition.

	Trial Condition			SDA
	Invalid-horizonal	Invalid-vertical	Valid	
<b>Experiment 6</b>				
Horizontal meridian	734.23 (7.88)	752.60 (8.00)	507.89 (11.83)	18.37 (10.09)
Vertical meridian	708.09 (8.42)	776.64 (9.09)	512.12 (11.52)	<b>68.55 (8.11)</b>
No meridian control	710.58 (8.68)	769.34 (8.04)	512.57 (11.13)	<b>68.76 (7.68)</b>
<b>Experiment 7</b>				
Horizontal meridian (0%)	825.45 (9.28)	876.91 (10.44)	522.00 (14.19)	<b>51.46 (6.29)</b>
Vertical meridian (0%)	822.33 (9.07)	872.85 (10.82)	522.01 (11.40)	<b>50.52 (6.29)</b>
Horizontal meridian (33%)	836.06 (10.47)	879.33 (9.43)	520.78 (12.51)	<b>43.27 (9.12)</b>
Vertical meridian (33%)	824.80 (11.56)	877.97 (11.04)	523.58 (13.32)	<b>53.17 (9.12)</b>
Horizontal meridian (66%)	825.92 (10.60)	862.43 (9.64)	520.73 (12.83)	<b>36.51 (8.99)</b>
Vertical meridian (66%)	828.96 (9.87)	878.19 (9.71)	517.72 (11.25)	<b>49.23 (8.99)</b>
Horizontal meridian (100%)	848.67 (10.81)	863.96 (10.40)	516.31 (11.64)	15.29 (10.46)
Vertical meridian (100%)	797.60 (10.92)	874.25 (9.72)	519.50 (11.46)	<b>76.65 (10.46)</b>
<b>Experiment 8</b>				
Horizontal meridian	660.10 (5.78)	698.14 (5.94)	511.54 (7.75)	<b>38.05 (6.80)</b>
Vertical meridian	637.81 (6.86)	709.51 (7.12)	513.03 (8.44)	<b>71.70 (5.53)</b>
No meridian control	654.45 (7.40)	720.55 (8.04)	510.81 (9.21)	<b>66.10 (6.48)</b>
<b>Experiment 9</b>				
Horizontal meridian	797.28 (9.56)	857.69 (11.54)	538.14 (11.76)	<b>60.41 (8.24)</b>
Vertical meridian	782.69 (7.75)	867.59 (9.42)	533.48 (12.19)	<b>84.90 (6.54)</b>
No meridian control	785.11 (9.01)	866.45 (11.11)	539.54 (10.64)	<b>81.34 (8.37)</b>
<b>Experiment 10</b>				
Horizontal meridian	795.13 (7.99)	863.10 (11.39)	541.20 (15.15)	<b>67.97 (7.49)</b>
Vertical meridian	797.17 (8.97)	871.81 (9.57)	540.83 (13.08)	<b>74.64 (8.07)</b>
No meridian control	802.49 (9.15)	866.96 (10.82)	538.50 (14.29)	<b>64.47 (8.44)</b>

*Note.* Across all experiments, there were significant space-based cueing effects such that valid RTs were significantly faster than invalid RTs, all  $ps < .001$ . SDA = invalid-vertical RTs minus invalid-horizonal RTs. Significant SDAs are bolded. Values in parentheses are *SEMs*.

**Response latencies.** The dependent variable was mean RT for correct responses, reported in Table 6. As in Experiment 1, mean RT differences were calculated by subtracting mean raw RTs to valid targets from mean RTs to invalid-horizonal targets and invalid-vertical targets for

each meridian condition. Next, mean RT differences were submitted to a 2 x 3 repeated measures ANOVA with Shift Direction (horizontal, vertical) and Meridian (horizontal, vertical, none) as within-subjects factors. The analysis revealed a main effect of Shift Direction,  $F(1,27) = 32.61$ ,  $p \leq .001$ ,  $\eta_p^2 = .55$ , indicating a significant difference in invalid target detection RT when reallocating object-based attention horizontally ( $M = 206.77$  ms,  $SEM = 4.25$  ms) versus vertically ( $M = 255.33$  ms,  $SEM = 4.25$  ms). The main effect of Meridian, however, was not significant,  $F(2,54) = 0.95$ ,  $p = .394$ ,  $\eta_p^2 = .034$ , indicating no significant difference in invalid target detection RT between the horizontal meridian enhancement condition ( $M = 235.52$  ms,  $SEM = 3.68$  ms), the vertical meridian enhancement condition ( $M = 230.24$  ms,  $SEM = 3.57$  ms), and the no meridian condition ( $M = 227.39$  ms,  $SEM = 3.10$  ms). The Shift Direction main effect was further qualified by a significant two-way interaction,  $F(2,54) = 6.25$ ,  $p = .004$ ,  $\eta_p^2 = .19$ .

The interaction between Shift Direction and Meridian describes the significant differences in the magnitude of the SDA as a function of meridian emphasis (See Fig. 18). For the vertical meridian enhancement condition, paired samples  $t$ -tests revealed a significant SDA, such that reallocating object-based attention horizontally ( $M = 195.97$  ms,  $SEM = 6.61$  ms) was significantly faster than reallocating vertically ( $M = 264.52$  ms,  $SEM = 6.61$  ms),  $t(27) = 5.19$ ,  $p < .001$ ,  $d = 0.70$ . A similar significant SDA was observed for the no meridian baseline control, where horizontal shifts of attention ( $M = 198.01$  ms,  $SEM = 6.25$  ms) were significantly faster than vertical shifts of attention ( $M = 256.77$  ms,  $SEM = 6.25$  ms),  $t(27) = 4.70$ ,  $p < .001$ ,  $d = 0.62$ . Thus, a horizontal advantage SDA was observed when the vertical meridian was emphasized (68.55 ms), which did not significantly differ from the SDA in the no meridian control condition (58.76 ms),  $t(27) = 0.81$ ,  $p = .428$ ,  $d = 0.14$ . However, for the horizontal meridian enhancement condition, horizontal shifts ( $M = 226.33$  ms,  $SEM = 5.30$  ms) were

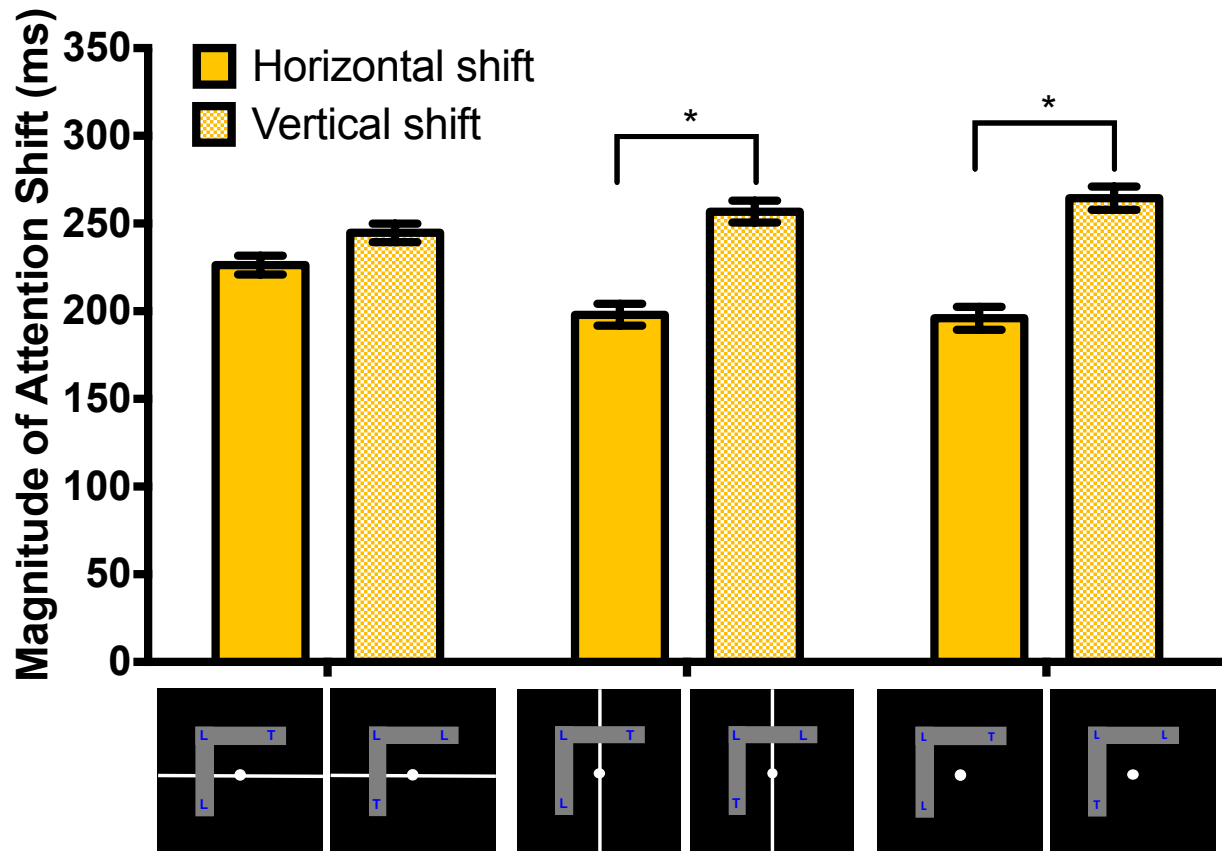

**Figure 18. Mean response latencies in Experiment 6 (Visible line).** “Magnitude of Attention Shift” measured for the Shift Direction x Meridian interaction in Experiment 6. The error bars represent the standard error of the mean for within-subjects design.

statistically equivalent to vertical shifts of attention ( $M = 244.70$  ms,  $SEM = 5.30$  ms),  $t(27) = 1.73$ ,  $p = .095$ ,  $d = 0.19$ . The JZS Bayes Factor for the horizontal meridian enhancement condition was 1.34 in favor of the null hypothesis. The SDA was eliminated when the horizontal meridian was emphasized (18.37 ms), which was significantly smaller than the SDAs observed in the vertical meridian enhancement condition,  $t(27) = 3.02$ ,  $p = .005$ ,  $d = 0.79$ , and the no meridian enhancement condition,  $t(27) = 2.53$ ,  $p = .018$ ,  $d = 0.66$ .

Additional analyses of the two-way interaction revealed a significant simple effect of Meridian on invalid-horizontal shift RTs,  $F(2,54) = 5.08$ ,  $p = .009$ ,  $\eta_p^2 = .16$ , such that

reallocating attention horizontally was significantly slower in the horizontal meridian enhancement condition versus the vertical meridian enhancement condition,  $t(27) = 2.49, p = .019, d = 0.31$ , and the no meridian condition,  $t(27) = 2.58, p = .016, d = 0.30$ . Invalid-horizontal shift RTs did not differ between the vertical and no meridian enhancement conditions,  $t(27) = 0.24, p = .810, d = 0.02$ . The simple effect of Meridian on invalid-vertical shift RTs was marginally significant,  $F(2,54) = 2.78, p = .071, \eta_p^2 = .09$ . Invalid-vertical shift RTs were significantly faster in the horizontal meridian condition than in the vertical meridian condition,  $t(27) = 2.28, p = .031, d = 0.20$ . Vertical shifts did not differ between the no meridian condition and the horizontal meridian condition or vertical meridian condition, all  $ts < 1.4$ , all  $ps > .17$ .

When all 32 participants were included, a similar main effect of Shift Direction was observed,  $F(1,31) = 33.63, p < .001, \eta_p^2 = .52$ , as well as a significant two-way interaction,  $F(2,62) = 5.94, p = .004, \eta_p^2 = .16$ . Similarly, the main effect of Meridian was not observed,  $F(2,62) = 1.06, p = .352, \eta_p^2 = .03$ .

**Error rates.** Mean error rates for each trial condition are reported in Table 7. These values were submitted to a 3 x 3 repeated measures ANOVA with Meridian (horizontal, vertical, none) and Trial Condition (invalid-horizontal, invalid-vertical, and valid) as within-subjects factors. There were no significant main effects or interactions, all  $Fs < 2$ , all  $ps > .2$ , nor any significant pairwise comparisons, all  $ts < 2$ , all  $ps > .11$ , indicating no statistically significant differences in error rates across trial conditions.

## Discussion

The results from Experiment 6 revealed that horizontal shifts of object-based attention across the vertical meridian were significantly faster than vertical shifts across the horizontal meridian when the local feature contrast of the vertical meridian was enhanced with a white

Table 7. Mean error rates (percent of misses) in Experiments 6-10, by meridian enhancement condition.

	Trial Condition		
	Invalid-horizonal	Invalid-vertical	Valid
Experiment 6			
Horizontal meridian	2.57 (0.33)	2.01 (0.45)	1.77 (0.20)
Vertical meridian	2.79 (0.45)	1.79 (0.39)	1.77 (0.25)
No meridian control	1.67 (0.32)	2.23 (0.35)	2.12 (0.20)
Experiment 7			
Horizontal meridian (0%)	1.33 (0.21)	1.04 (0.23)	0.92 (0.11)
Vertical meridian (0%)	1.04 (0.21)	0.89 (0.14)	0.94 (0.13)
Horizontal meridian (33%)	1.04 (0.17)	1.19 (0.22)	1.10 (0.12)
Vertical meridian (33%)	1.64 (0.20)	1.79 (0.26)	0.98 (0.18)
Horizontal meridian (66%)	1.33 (0.22)	1.04 (0.18)	1.40 (0.17)
Vertical meridian (66%)	1.34 (0.23)	0.14 (0.16)	0.12 (0.23)
Horizontal meridian (100%)	1.49 (0.24)	1.71 (0.20)	1.29 (0.20)
Vertical meridian (100%)	1.56 (0.18)	1.34 (0.16)	1.51 (0.11)
Experiment 8			
Horizontal meridian	3.35 (0.41)	3.79 (0.50)	3.53 (0.39)
Vertical meridian	3.46 (0.48)	3.23 (0.53)	3.44 (0.29)
No meridian control	3.79 (0.56)	3.57 (0.48)	3.23 (0.27)
Experiment 9			
Horizontal meridian	4.35 (0.51)	2.90 (0.41)	3.32 (0.39)
Vertical meridian	3.57 (0.50)	3.13 (0.50)	2.70 (0.30)
No meridian control	2.34 (0.38)	3.79 (0.44)	2.60 (0.34)
Experiment 10			
Horizontal meridian	3.79 (0.60)	3.35 (0.60)	2.99 (0.34)
Vertical meridian	3.01 (0.55)	2.79 (0.51)	3.16 (0.47)
No meridian control	3.13 (0.33)	2.79 (0.32)	3.20 (0.36)

*Note.* Values in parentheses are *SEMs*.

visible line. This effect did not differ from the no meridian baseline control, suggesting that a strong local feature contrast manipulation of the vertical meridian is not effective in modulating the SDA. This observation also suggests that shifts of attention across the vertical meridian may not play a causal role in the emergence of the SDA. Critically, there was no difference between horizontal and vertical shifts of object-based attention when the horizontal meridian was enhanced with a white visible line, indicating that a strong local feature contrast manipulation of

the horizontal meridian is capable of reducing and, in this case, eliminating the SDA. This result implicates the horizontal meridian in a causal role in producing the SDA. Taken together, these results support our hypotheses that the SDA is sensitive to strong manipulations of the horizontal meridian and not the vertical meridian.

The pattern of performance observed in Experiment 6 suggests that a strong manipulation of the horizontal meridian with a visible line is capable of eliminating the anisotropy between horizontal and vertical shifts of object-based attention. In the next experiment, the contrast level of the visible line was manipulated to determine whether the contrast level of the visible line is a contributing factor in the elimination of the SDA.

#### **Experiment 7: High local feature contrast manipulation with varying visible lines**

Having established that a visible horizontal meridian at 100% contrast is sufficient at ameliorating the SDA, the goal of Experiment 7 was to examine whether the SDA can be eliminated by visible meridians of varying contrasts. In other words, we were interested in whether the meridian enhancement need be a line at 100% contrast in order to modulate the SDA or if a line, in general and regardless of contrast, is capable of modulating the SDA. We expected to replicate our results from Experiment 6, in which the SDA was eliminated with a visible line at 100% contrast on the horizontal meridian; however, we also predicted that the SDA would not be modulated as the contrast of the horizontal line decreased (e.g., 66% or 33%). We also hypothesized that any contrast changes to the visible line on the vertical meridian would not significantly modulate the SDA. These results would support the idea that the SDA is eliminated by perceptually strong and distinctive enhancements, such as a white line at 100% contrast line relative to the black background and is unaffected by perceptually weaker and ambiguous enhancements such as a dark gray line at 33% contrast relative to the black background.

## Method

All aspects of Experiment 7 were identical to those of Experiment 6, except as described below.

**Participants.** Thirty-one new individuals from the University of Wisconsin-Milwaukee and surrounding community ( $M_{\text{age}} = 20.68$  years,  $SD_{\text{age}} = 2.44$  years; 18 women, 13 men) participated in this experiment. Participants had the option of receiving 2 hours of extra credit toward a Psychology course or \$20 as compensation for their participation.

**Apparatus, stimuli, design, and procedure.** Visual field meridians were emphasized with a visible line at 33%, 66%, and 100% contrast on the horizontal meridian or the vertical meridian (See Fig. 17). A no meridian enhancement condition (or, 0% contrast) served as a baseline control.

Participants completed two experimental sessions. One session contained 12 blocks of trials, each containing 80 trials for a total of 1920 trials. Horizontal and vertical meridian conditions were randomly intermixed within blocks. That is, participants were equally likely to get a horizontal meridian or vertical meridian on any given trial. Trials were blocked by contrast, with each session containing 4 blocks of each contrast. Block order was randomized for each session.

Blocks consisted of 60% valid trials (48 trials per block; 1152 total), 10% invalid-horizontal trials (8 trials per block; 192 total), and 10% invalid-vertical trials (8 trials per block; 192 total). To ensure selective responding, the remaining trials were composed of “catch trials” (20%; 16 trials per block; 384 total) in which only non-target letters appeared on the object. These proportions were split evenly between the four contrast conditions (i.e., 288 valid trials, 48

invalid-horizontal trials, 48 invalid-vertical trials, and 96 catch trials for the 33% contrast condition).

## Results

**Data quality.** The original sample of 31 participants had a mean false alarm rate of 9% ( $SD = 8\%$ ) and a mean miss rate of 3% ( $SD = 4\%$ ). Participants who responded to more than 96 catch trials (or, a 25% false alarm rate) and/or missed 192 target-present trials (or, a 10% miss rate) were discarded from the original sample. As such, a total of 3 participants with an excessively high false alarm rate ( $n = 2$ ;  $M = 31\%$ ,  $SD = 4\%$ ) on catch trials and/or number of misses ( $n = 1$ ;  $N = 301$  trials) on target-present trials were discarded. This resulted in a final sample of 28 participants ( $M_{age} = 20.75$  years,  $SD_{age} = 2.46$  years; 17 women, 11 men) with a mean false alarm rate of 7% ( $SD = 5\%$ ) and a mean miss rate of 2% ( $SD = 2\%$ ). An independent samples  $t$ -test revealed a marginally significant larger false alarm rate for the excluded participants compared to the included participants,  $t(1.23) = 7.32$ ,  $p = .058$ ,  $d = 4.85$ . Additionally, anticipatory responses (RT less than 200 ms) were discarded.

**Response latencies.** The dependent variable was mean RT for correct responses, reported in Table 6. Again, mean RT differences were calculated by subtracting mean raw RTs to valid targets from mean RTs to targets in the invalid-horizontal location and invalid-vertical location for each contrast and meridian condition. Next, mean RT differences were submitted to a 4 x 2 x 2 repeated measures ANOVA with Contrast (0%, 33%, 66%, 100%), Meridian (horizontal, vertical), and Shift Direction (horizontal, vertical) as within-subjects factors. The analysis revealed a main effect of Shift Direction,  $F(1,27) = 17.06$ ,  $p < .001$ ,  $\eta_p^2 = .39$ , indicating a significant difference in invalid target detection RT when reallocating object-based attention horizontally ( $M = 305.90$  ms,  $SEM = 5.69$  ms) versus vertically ( $M = 352.91$  ms,  $SEM = 5.69$

ms). There was no main effect of Contrast,  $F(3,81) = 0.25, p = .864, \eta_p^2 = .01$  (0% contrast:  $M = 328.22$  ms,  $SEM = 3.57$  ms; 33% contrast:  $M = 329.65$  ms,  $SEM = 3.69$  ms; 66% contrast:  $M = 332.36$  ms,  $SEM = 4.47$  ms; 100% contrast:  $M = 327.38$  ms,  $SEM = 3.42$  ms), or Meridian,  $F(1,27) = 1.61, p = .216, \eta_p^2 = .08$  (horizontal meridian condition:  $M = 332.39$  ms,  $SEM = 2.36$  ms; vertical meridian vertical:  $M = 326.42$  ms,  $SEM = 2.36$  ms). The main effect, however, was qualified by a significant two-way interaction between Meridian x Shift Direction,  $F(1,27) = 4.48, p = .044, \eta_p^2 = .14$ , as well as a marginally significant three-way interaction,  $F(3,81) = 2.66, p = .054, \eta_p^2 = .09$ . All other interactions did not reach significance, all  $F_s < 2$ , all  $p_s > .1$ . The interactions are each detailed below.

When all 31 participants were included, we observed a similar main effect of Shift Direction,  $F(1,28) = 18.11, p < .001, \eta_p^2 = .39$ , as well as a significant Meridian x Shift Direction interaction,  $F(1,28) = 4.88, p = .036, \eta_p^2 = .15$ . The three-way interaction, however, was not significant,  $F(3,84) = 2.16, p = .099, \eta_p^2 = .07$ . All other main effects and interactions did not reach significance, all  $F_s < 1.8$ , all  $p_s > .17$ .

***Meridian and shift direction.*** The interaction between Meridian and Shift Direction describes the significant differences in the magnitude of the SDA as a function of meridian emphasis (See Fig. 19). When the horizontal meridian was emphasized, paired samples  $t$ -tests revealed a significant SDA, such that reallocating object-based attention horizontally ( $M = 314.07$  ms,  $SEM = 5.89$  ms) was significantly faster than reallocating vertically ( $M = 350.70$  ms,  $SEM = 5.89$  ms),  $t(27) = 3.11, p = .004, d = 0.36$ . A significant SDA was also observed for the vertical meridian condition. Similarly, horizontal shifts of attention ( $M = 297.72$  ms,  $SEM = 6.49$  ms) were faster than vertical shifts of attention ( $M = 355.11$  ms,  $SEM = 6.48$ ms),  $t(27) = 4.43, p < .001, d = 0.60$ . Thus, the interaction between Meridian and Shift Direction was driven by a

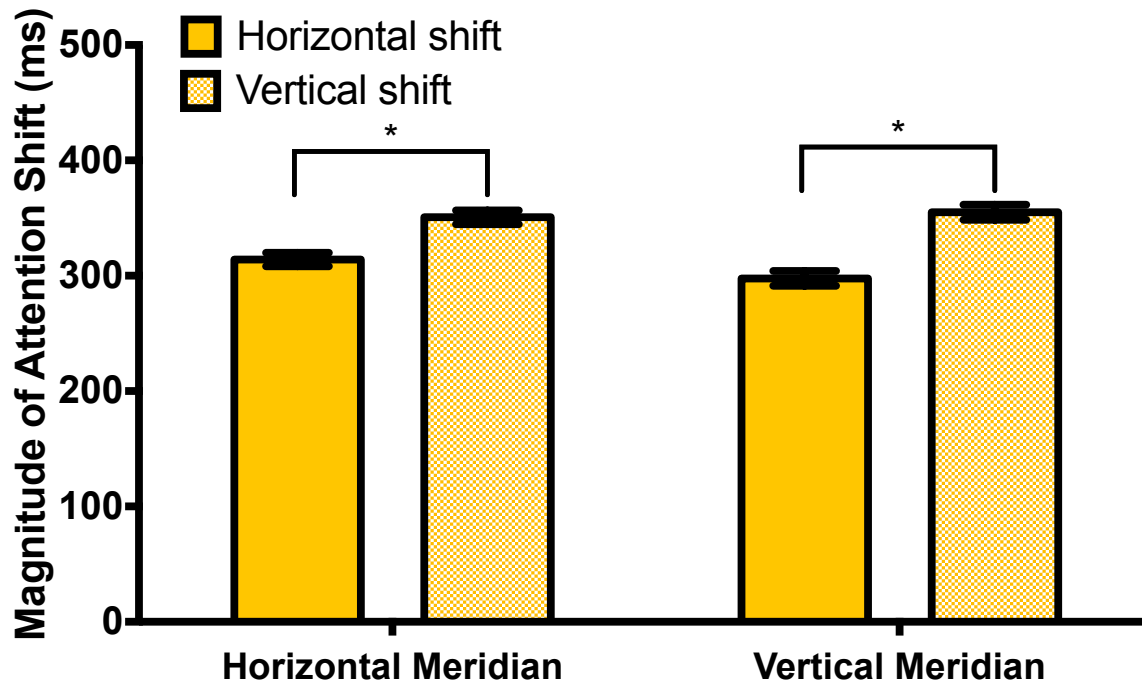
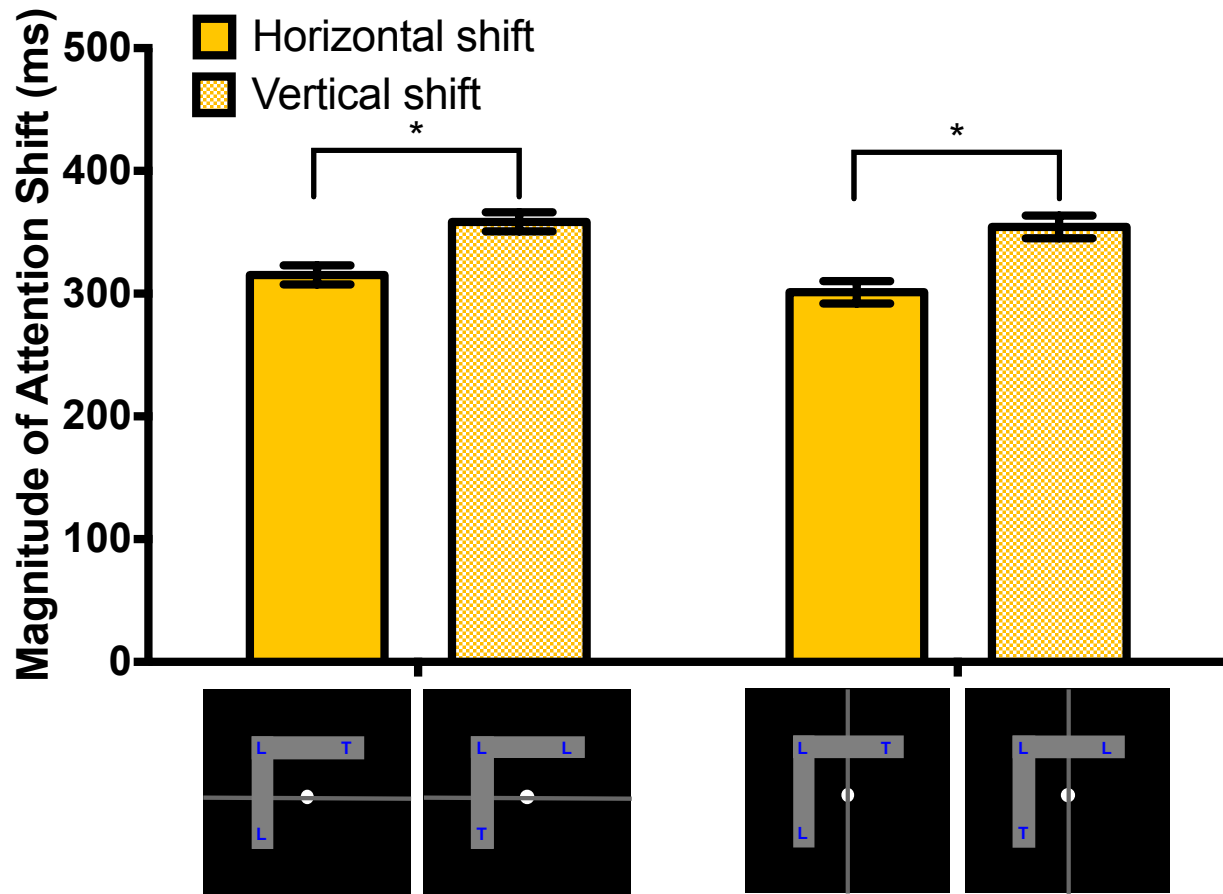

**Figure 19. Meridian x Shift Direction in Experiment 7 (Variable contrast line).** “Magnitude of Attention Shift” measured for the Meridian x Shift Direction interaction in Experiment 7. The error bars represent the standard error of the mean for within-subjects design.

significantly larger anisotropy between horizontal and vertical shifts for the vertical meridian emphasis (57.39 ms) versus the horizontal meridian emphasis (36.63 ms).

**Contrast, meridian, and shift direction.** In order to understand the three-way interaction, two sets of analyses were performed, separately, by partitioning contrast and meridian.

*Partitioned by contrast.* A 2 x 2 repeated measures ANOVA was first conducted on the mean response latencies for the 33% contrast condition, with Meridian and Shift Direction as within-subjects factors. The analysis produced a significant main effect of Shift Direction,  $F(1,27) = 11.39, p = .002, \eta_p^2 = .30$ , indicating that participants’ response latencies were faster when the target appeared at the invalid-horizontal location ( $M = 308.25$  ms,  $SEM = 7.14$  ms) versus the invalid-vertical location ( $M = 356.47$  ms,  $SEM = 7.14$  ms). There was no main effect of Meridian,  $F(1,27) = 0.85, p = .365, \eta_p^2 = .03$  (horizontal meridian enhancement condition:  $M$



**Figure 20. Meridian x Shift Direction interaction for 33% contrast lines in Experiment 7.** “Magnitude of Attention Shift” measured for the Meridian x Shift Direction interaction for 33% contrast lines in Experiment 7. The error bars represent the standard error of the mean for within-subjects design.

= 336.91 ms,  $SEM = 4.94$  ms; vertical meridian enhancement condition:  $M = 327.80$  ms,  $SEM = 4.94$  ms) or interaction,  $F(1,27) = 0.30$ ,  $p = .592$ ,  $\eta_p^2 = .01$ . When the horizontal meridian was emphasized, a paired samples  $t$ -test revealed a significant SDA, such that reallocating object-based attention horizontally ( $M = 315.28$  ms,  $SEM = 7.76$  ms) was significantly faster than reallocating vertically ( $M = 358.55$  ms,  $SEM = 7.76$  ms),  $t(27) = 2.79$ ,  $p = .010$ ,  $d = 0.40$  (See Fig. 20). This analysis also revealed a significant SDA for the vertical meridian enhancement condition, such that horizontal shifts of attention ( $M = 301.22$  ms,  $SEM = 9.13$  ms) were

significantly faster than vertical shifts of attention ( $M = 354.39$  ms,  $SEM = 9.13$  ms),  $t(27) = 2.91$ ,  $p = .007$ ,  $d = 0.46$ . The SDA for the horizontal meridian condition (43.27 ms) was not statistically different than the SDA for the vertical meridian condition (53.17 ms).

A second 2 x 2 ANOVA was conducted on the mean response latencies in the 66% contrast condition. The analysis revealed a significant main effect of Shift Direction,  $F(1,27) = 10.77$ ,  $p = .003$ ,  $\eta_p^2 = .29$ , indicating that participants' response latencies were faster when the target appeared at the invalid-horizontal location ( $M = 308.21$  ms,  $SEM = 6.53$  ms) versus the invalid-vertical location ( $M = 351.08$  ms,  $SEM = 6.53$  ms). There was no main effect of Meridian,  $F(1,27) = 1.95$ ,  $p = .174$ ,  $\eta_p^2 = .07$  (horizontal meridian enhancement condition:  $M = 323.44$  ms,  $SEM = 4.45$  ms; vertical meridian enhancement condition:  $M = 335.85$  ms,  $SEM = 4.45$  ms), or interaction,  $F(1,27) = 0.50$ ,  $p = .485$ ,  $\eta_p^2 = .02$ . When the horizontal meridian was emphasized, a paired samples  $t$ -test revealed a significant SDA, such that reallocating object-based attention horizontally ( $M = 305.19$  ms,  $SEM = 7.84$  ms) was significantly faster than reallocating vertically ( $M = 341.70$  ms,  $SEM = 7.84$  ms),  $t(27) = 2.33$ ,  $p = .028$ ,  $d = 0.33$  (See Fig. 21). This analysis also revealed a significant SDA for the vertical meridian enhancement condition, such that horizontal shifts of attention ( $M = 311.23$  ms,  $SEM = 8.01$  ms) were faster than vertical shifts of attention ( $M = 360.46$  ms,  $SEM = 8.01$  ms),  $t(27) = 3.07$ ,  $p = .005$ ,  $d = 0.50$ . Thus, the SDA for the horizontal meridian enhancement condition (36.51 ms) was not statistically different than the SDA for the vertical meridian enhancement condition (49.23 ms).

A third 2 x 2 ANOVA was conducted on the mean response latencies in the 100% contrast condition. The analysis produced a significant main effect of Shift Direction,  $F(1,27) = 10.79$ ,  $p = .003$ ,  $\eta_p^2 = .29$ , indicating that participants' response latencies were faster when the target appeared in the invalid-horizontal location ( $M = 305.23$  ms,  $SEM = 7.00$  ms) versus the

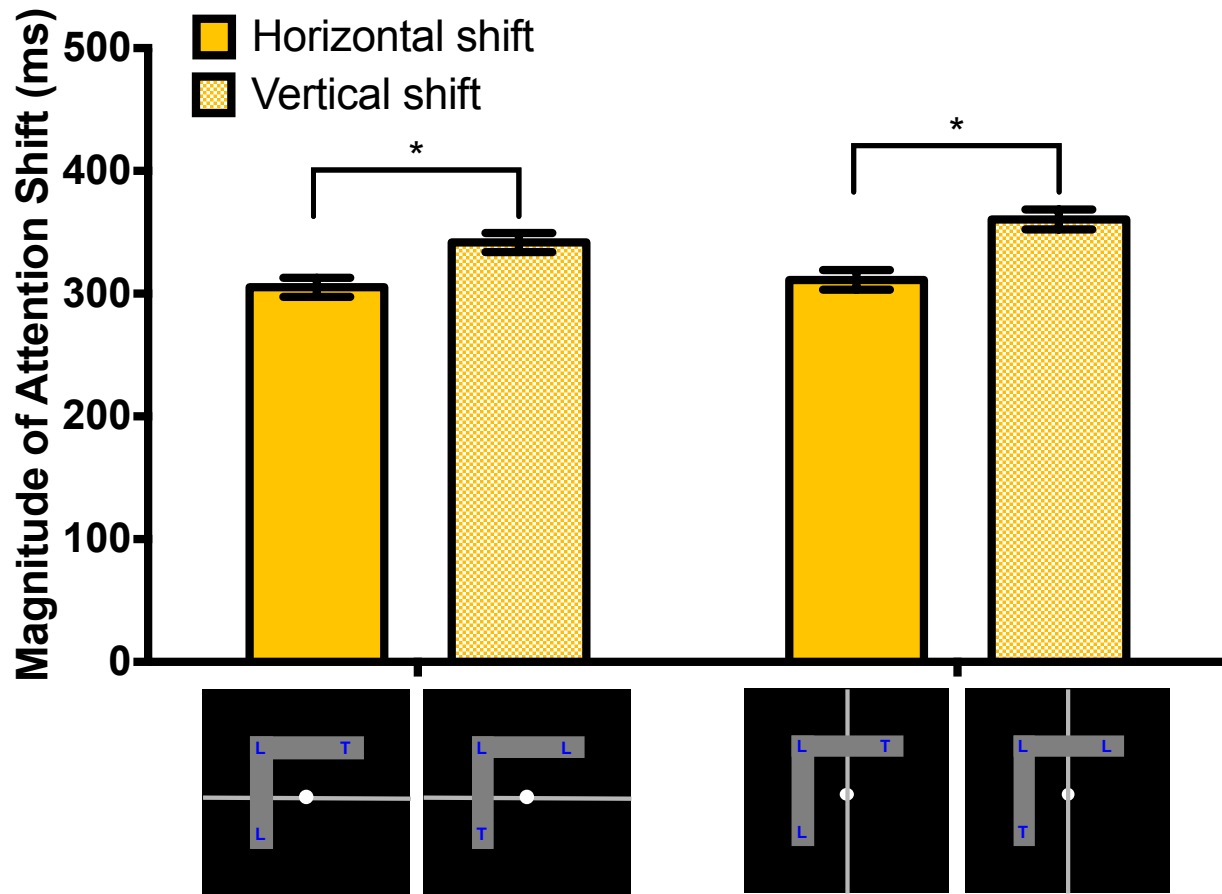

**Figure 21. Meridian x Shift Direction interaction for 66% contrast lines in Experiment 7.** “Magnitude of Attention Shift” measured for the Meridian x Shift Direction interaction for 66% contrast lines in Experiment 7. The error bars represent the standard error of the mean for within-subjects design.

invalid-vertical location ( $M = 351.20$  ms,  $SEM = 7.00$  ms). The analysis also produced a significant main effect of Meridian,  $F(1,27) = 6.51, p = .017, \eta_p^2 = .19$ , indicating that participants’ response latencies were faster when the target appeared in the vertical meridian enhancement condition ( $M = 316.42$  ms,  $SEM = 4.62$  ms) versus the horizontal meridian enhancement condition ( $M = 340.01$  ms,  $SEM = 4.62$  ms). These main effects were qualified by a significant two-way interaction,  $F(1,27) = 8.60, p = .007, \eta_p^2 = .24$  (See Fig. 22). When the vertical meridian was emphasized, a paired samples  $t$ -test revealed a significant SDA, such that

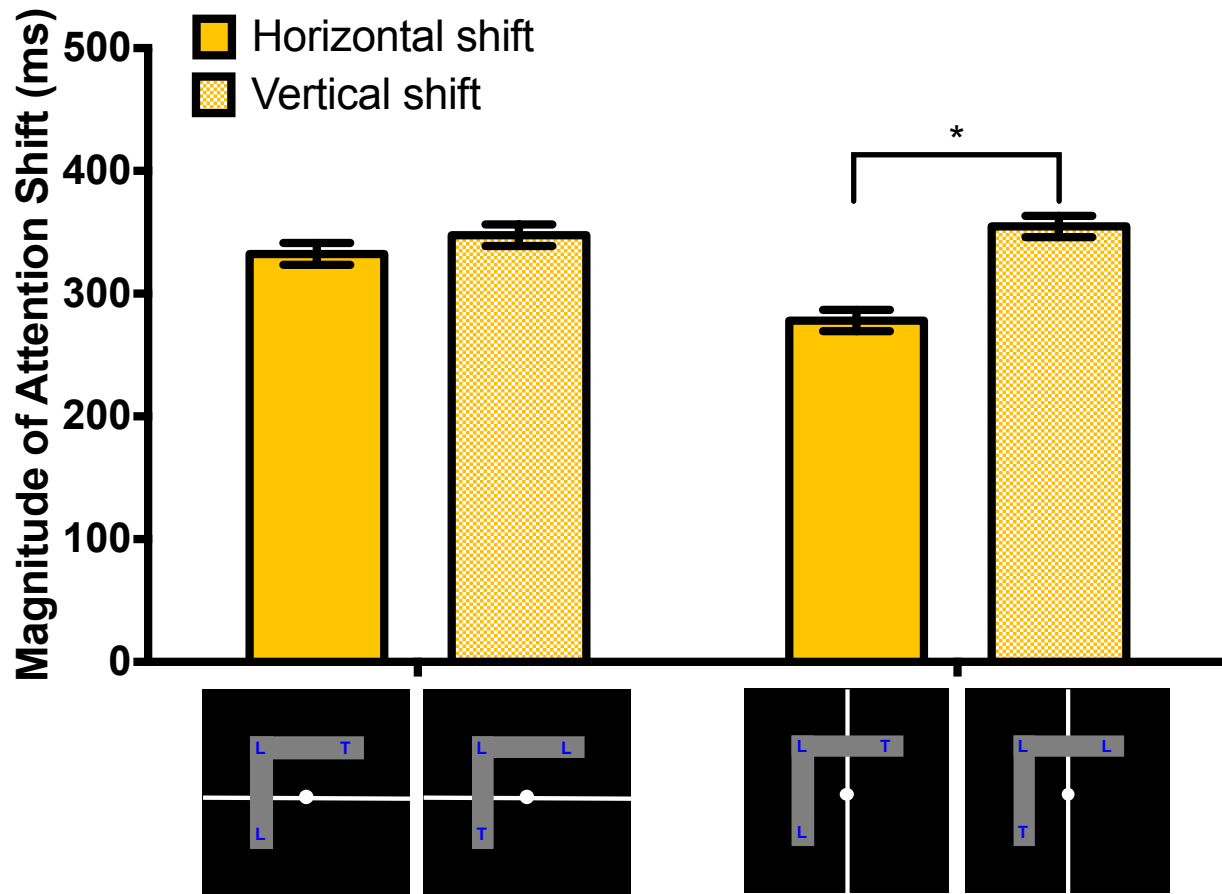
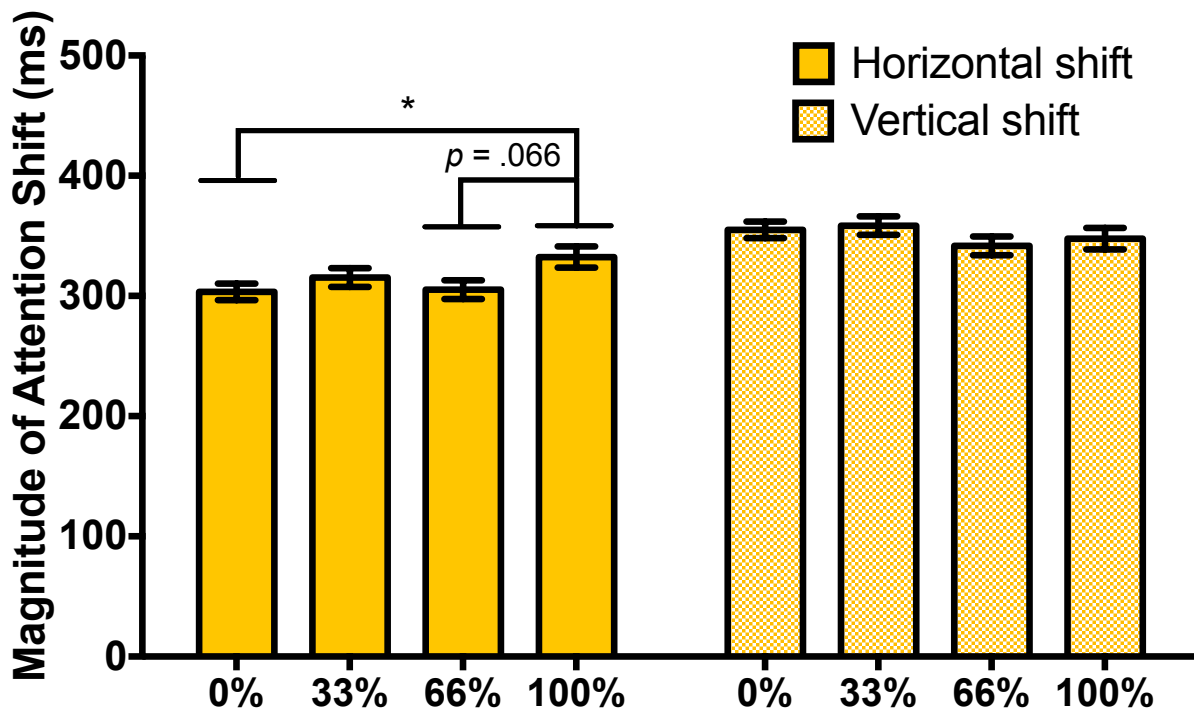

**Figure 22. Meridian x Shift Direction interaction for 100% contrast lines in Experiment 7.** “Magnitude of Attention Shift” measured for the Meridian x Shift Direction interaction for 100% contrast lines in Experiment 7. The error bars represent the standard error of the mean for within-subjects design.

reallocating object-based attention horizontally ( $M = 278.11$  ms,  $SEM = 8.61$  ms) was significantly faster than reallocating vertically ( $M = 354.75$  ms,  $SEM = 8.61$  ms),  $t(27) = 4.45$ ,  $p < .001$ ,  $d = 0.75$ . However, as expected, the SDA was eliminated when the horizontal meridian was emphasized, With a 100% contrast visible line on the horizontal meridian, participants were equally as fast shifting attention horizontally ( $M = 332.36$  ms,  $SEM = 8.87$  ms) as they were shifting attention vertically ( $M = 347.66$  ms,  $SEM = 8.87$  ms),  $t(27) = 0.86$ ,  $p = .396$ ,  $d = 0.15$ . The JZS Bayes Factor was 3.56, in favor of the null hypothesis. Thus, the interaction between

Meridian and Shift Direction for 100% contrast meridians was driven by a significantly larger SDA when the vertical meridian was emphasized (76.64 ms) versus when the horizontal meridian was emphasized (15.30 ms).

*Partitioned by meridian.* A 2 x 4 repeated measures ANOVA was first conducted on the mean response latencies for the horizontal meridian enhancement condition, with Shift Direction and Contrast as within-subjects factors. The analysis revealed a main effect of Shift Direction,  $F(1,27) = 9.66, p = .004, \eta_p^2 = .26$ , indicating that participants' response latencies were faster shifting attention horizontally ( $M = 314.07$  ms,  $SEM = 5.89$  ms) versus vertically ( $M = 350.70$  ms,  $SEM = 5.89$  ms). The main effect of contrast and the interaction were not significant, all  $F$ s < 1.7, all  $p$ s > .18. Two additional one-way ANOVAs with Contrast as a single factor were performed for both shift directions (See Fig. 23). There was no effect of contrast on vertical



**Figure 23. Contrast x Shift Direction interaction for the horizontal meridian in Experiment 7.** “Magnitude of Attention Shift” measured for the Contrast x Shift Direction interaction for the horizontal meridian in Experiment 7. The error bars represent the standard error of the mean for within-subjects design.

shifts,  $F(3,81) = 0.78, p = .506, \eta_p^2 = .03$ , nor any significant paired comparisons, all  $ts < 1.7$ , all  $ps > .1$ . There was also no effect of contrast on horizontal shifts,  $F(3,81) = 1.93, p = .131, \eta_p^2 = .07$ ; however, paired comparisons revealed that horizontal shifts in the 100% contrast condition were significantly slower than horizontal shifts in the 0% contrast condition,  $t(27) = 2.32, p = .028, d = 0.26$ , and marginally slower than horizontal shifts in the 66% condition,  $t(27) = 1.91, p = .066, d = 0.25$ .

A second repeated measures ANOVA was conducted on the mean response latencies for the vertical meridian enhancement condition and a similar pattern of results was found. There was a main effect of Shift Direction,  $F(1,27) = 19.58, p < .001, \eta_p^2 = .42$ , indicating that participants' response latencies were faster shifting attention horizontally ( $M = 297.72$  ms,  $SEM = 6.49$  ms) versus vertically ( $M = 355.11$  ms,  $SEM = 6.49$  ms). The main effect of contrast and the interaction were also not significant, all  $Fs < 1.4$ , all  $ps > .25$ . The one-way ANOVA with Contrast revealed no effect on vertical shifts,  $F(3,81) = 0.19, p = .905, \eta_p^2 = .01$ , nor any significant paired comparisons, all  $ts < 0.8$ , all  $ps > .4$  (See Fig. 24). There was also no effect of contrast on horizontal shifts,  $F(3,81) = 2.26, p = .088, \eta_p^2 = .08$ , though paired comparisons revealed that horizontal shifts in the 100% contrast condition were significantly faster than horizontal shifts in the 66% contrast condition,  $t(27) = 2.39, p = .024, d = 0.32$ , and marginally faster than horizontal shifts in the 0% contrast condition,  $t(27) = 1.97, p = .059, d = 0.22$ .

### ***Analyzing the SDAs.***

*Within-experiment analysis.* SDAs were computed, separately for each meridian, and submitted to a two one-way repeated-measures ANOVAs with contrast as a single factor. There was no effect of contrast on the SDAs for either the horizontal meridian enhancement condition,  $F(3,81) = 1.66, p = .183, \eta_p^2 = .06$ , or the vertical meridian enhancement condition,  $F(3,81) =$

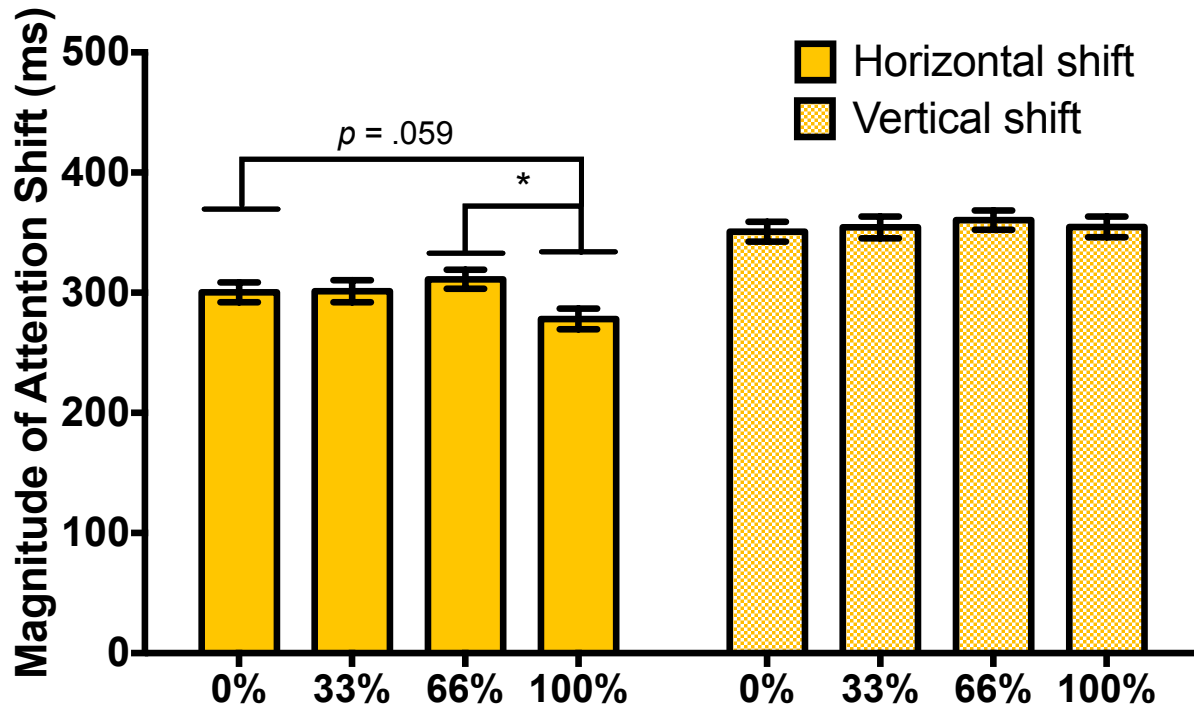

**Figure 24. Contrast x Shift Direction interaction for the vertical meridian in Experiment 7.** “Magnitude of Attention Shift” measured for the Contrast x Shift Direction interaction for the vertical meridian in Experiment 7. The error bars represent the standard error of the mean for within-subjects design.

1.04,  $p = .379$ ,  $\eta_p^2 = .04$  (See Fig. 25). However, in the horizontal meridian enhancement condition, the SDA for the 100% contrast line (15.30 ms) was significantly smaller than the SDA for the 0% contrast no meridian baseline (51.46 ms),  $t(27) = 2.34$ ,  $p = .027$ ,  $d = 0.43$ . No other pairwise comparisons were significant, all  $ts < 1.5$ , all  $ps > .15$ .

*Between-experiment analysis.* The SDAs observed from this experiment were also directly compared to the SDAs measured in Experiment 6 to assess any systematic between-experiment differences (See Fig. 25). Both experiments contained a similar method for enhancing the meridians (a visible line at 100% contrast placed on the horizontal or vertical meridian), and shared other aspects of the method, including the task, overall trial validity, and a no meridian/0% contrast enhancement baseline control. Here, SDAs were submitted to a 3 x 2

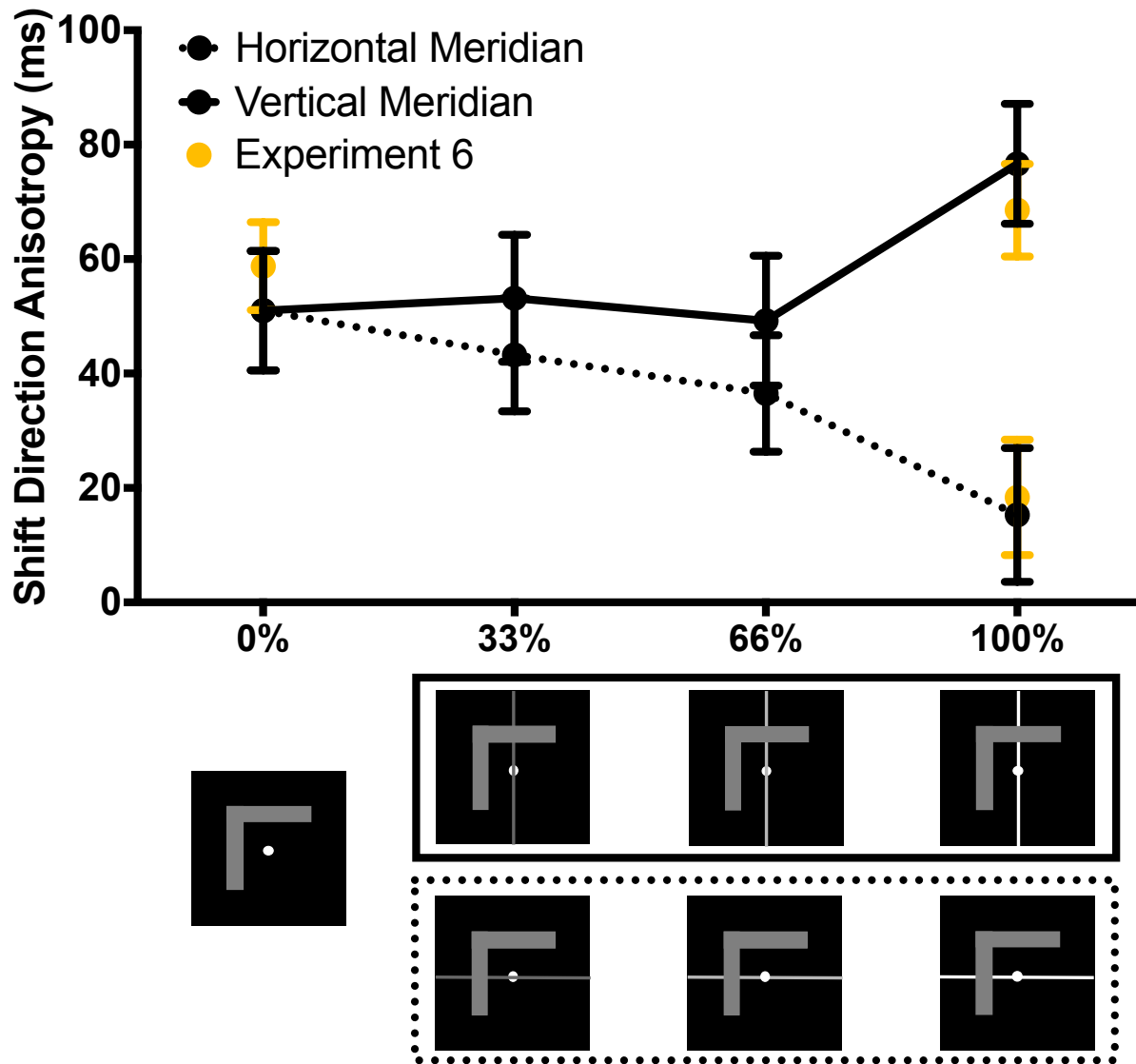

**Figure 25. SDAs in Experiment 7 and between-experiment comparison with Experiment 6.** “Shift Direction Anisotropy” obtained for each meridian and contrast value in Experiment 7. Yellow data points were obtained from Experiment 6 and compared to SDAs from Experiment 7. The error bars represent the standard error of the mean for within-subjects design.

repeated measures ANOVA with Meridian as a within-subjects factor and Experiment as a between-subjects factor. There was no main effect of Experiment,  $F(1,54) = 0.03, p = .875, \eta_p^2 = .00$ , or interaction involving the between-subjects factor,  $F(2,108) = 0.49, p = .614, \eta_p^2 = .01$ . Moreover, the results of three independent samples *t*-tests revealed no significant differences

between the SDAs from the current experiment and those obtained from Experiment 6 across the three meridian conditions, all  $t$ s < .4, all  $p$ s > .6.

**Error rates.** Mean error rates for each trial condition are reported in Table 7. These values were submitted to a 4 x 2 x 3 repeated measures ANOVA with Contrast (0%, 33%, 66%, 100%), Meridian (horizontal, vertical) and Trial Condition (invalid-horizontal, invalid-vertical, valid) as within-subjects factors. There were no significant main effects or interactions, all  $F$ s < 2.5, all  $p$ s > .1, nor any significant pairwise comparisons, all  $t$ s < 1.9, all  $p$ s > .09, indicating no statistically significant differences in error rates across trial conditions.

## **Discussion**

This experiment produced a many interesting results about the SDA and the role of the meridians in object-based attention. First, similar to our findings in Experiment 6, a 100% contrast line on the horizontal meridian eliminated the anisotropy between horizontal and vertical shifts compared to other contrast values and to manipulations of the vertical meridian. Although emphasizing the horizontal meridian with the 33% and 66% contrast lines did not completely eliminate the SDA, the magnitude of the SDA for these contrast values is reduced, albeit not significantly reduced compared to the 0% contrast baseline. The SDA magnitude for these contrast conditions also trends toward non-significance as contrast increases. In other words, SDA magnitude decreases with increasing contrast of the horizontal meridian. Conversely, SDA magnitude increased when the vertical meridian was enhanced, which was especially apparent when comparing the SDAs from the 66% and 100% contrast conditions.

Second, although vertical attention shifts were largely unaffected by any manipulations on the horizontal or vertical meridians, modulations of the SDA magnitude appear to be linked to two opposing trends. When the horizontal meridian is enhanced at 100% contrast, the SDA is

eliminated by a combination of slowed horizontal shift RTs across the vertical meridian and a trend for slightly faster vertical shift RTs across the horizontal meridian occurs. However, when the vertical meridian is enhanced at 100% contrast, the SDA increases due to speeded horizontal shift RTs horizontal and a trend.

Third, this experiment also demonstrates the consistency of the SDA as an object-based effect. Not only were the results similar between Experiments 6 and 7, but the magnitude of the SDAs from the 100% contrast conditions and no meridian baseline were statistically equivalent across these two experiments that utilized completely different participants. In addition to the SDA being larger and more prevalent than the same object advantage, evidence from this experiment (in addition to Experiments 1-3B) highlight the stability of this effect.

In summary, these results further demonstrate that the SDA is a malleable effect and that a 100% contrast line on the horizontal meridian is sufficient at eliminating the SDA while weaker contrast lines are capable of reducing the magnitude of, but not eliminating, the SDA. Furthermore, as in Experiment 6, any manipulation of the vertical meridian had no effect in significantly modulating the SDA. Together, these results indicate that the SDA is susceptible to strong manipulations of the horizontal meridian (a visible meridian at 100% contrast), but not weaker ones (a visible meridian at 33% contrast). The horizontal meridian, in particular, plays a causal role in the regulating of the SDA.

### **Experiment 8: High local feature contrast manipulation with colored background hemifields**

The findings from Experiments 6 and 7 showed that emphasizing the perceptual visibility of the horizontal meridian with a strong manipulation (e.g., a visible line at 100% contrast) can eliminate the SDA, suggesting that the horizontal meridian is important in the production of

anisotropic attention shifts. The goal of Experiment 8 was to apply another strong manipulation to the meridians with the goal of determining whether high local feature contrast manipulations, in general, are sufficient at eliminating the SDA or if a specific type of high local feature contrast manipulation is necessary to eliminate the SDA.

We, therefore, divided the background along the horizontal or vertical meridian into equal halves of different colors. Meridians were emphasized by the color boundary between the two background hemifields. Based on our results from Experiments 6 and 7, we hypothesized that a significant SDA would emerge when the vertical meridian was emphasized and that the SDA would be attenuated when the horizontal meridian was emphasized. This pattern of performance would suggest that strong local feature contrast manipulations of the horizontal meridian, in general, are capable of modulating the magnitude of the SDA and that crossings of the horizontal meridian lead to unequal attention shifts.

## **Method**

All aspects of Experiment 8 were identical to those of Experiment 6, except as described below.

**Participants.** Thirty-one new individuals from the University of Wisconsin-Milwaukee and surrounding community ( $M_{\text{age}} = 22.42$  years,  $SD_{\text{age}} = 3.62$  years; 23 women, 8 men) participated in this experiment.

**Apparatus, stimuli, design, and procedure.** Visual field meridians were emphasized with isoluminate colored background hemifields ( $18 \text{ cd/m}^2$ ; See Fig. 17). Two colors were arbitrarily chosen that did not conflict with the color presentation of the red cue and consisted of green halves (RGB: [0 53 0]) and blue halves (RGB: [0 25 150]). The background was divided equally along the meridians, such that each colored hemifield was  $48.48^\circ \times 15.15^\circ$  in the

horizontal meridian condition and  $15.15^\circ \times 48.48^\circ$  in the vertical meridian condition. For the horizontal meridian condition, participants were equally likely to get a green upper hemifield with a blue bottom hemifield or a blue upper hemifield with a green bottom hemifield. Likewise, for the vertical meridian condition, a given color was equally likely to appear on the left or the right hemifield, with the second color appearing on the other side. The no meridian baseline consisted of a background composed entirely of one color, which was also equally likely to appear across trials.

## Results

**Data quality.** The original sample of 31 participants had a mean false alarm rate of 11% ( $SD = 9\%$ ) and a mean miss rate of 4% ( $SD = 3\%$ ). Using the same exclusion criteria from Experiment 1, a total of 3 participants with an excessively high false alarm rate ( $n = 3$ ;  $M = 31\%$ ,  $SD = 4\%$ ) on catch trials and/or number of misses ( $n = 1$ ;  $N = 125$  trials) on target-present trials were discarded. This resulted in a final sample of 28 participants ( $M_{\text{age}} = 22.64$  years,  $SD_{\text{age}} = 3.72$  years; 22 women, 6 men) with a mean false alarm rate of 8% ( $SD = 7\%$ ) and a mean miss rate of 3% ( $SD = 2\%$ ). An independent samples  $t$ -test revealed a significantly larger false alarm rate for the excluded participants compared to the included participants,  $t(3.24) = 8.19$ ,  $p = .003$ ,  $d = 3.99$ . Additionally, anticipatory responses (RT less than 200 ms) were discarded.

**Response latencies.** The dependent variable was mean RT for correct responses, reported in Table 6. Again, mean RT differences were calculated by subtracting mean raw RTs to valid targets from mean RTs to targets in the invalid-horizontal location and invalid-vertical location for each meridian condition. Next, mean RT differences were submitted to a 2 x 3 repeated measures ANOVA with Shift Direction (horizontal, vertical) and Meridian (horizontal, vertical, none) as within-subjects factors. The analysis revealed a main effect of Shift Direction,  $F(1,27) =$

43.51,  $p < .001$ ,  $\eta_p^2 = .62$ , indicating a significant difference in invalid target detection RT when reallocating object-based attention horizontally ( $M = 138.99$  ms,  $SEM = 4.44$  ms) versus vertically ( $M = 197.61$  ms,  $SEM = 4.44$  ms). The main effect of Meridian, however, was not significant,  $F(2,54) = 2.20$ ,  $p = .121$ ,  $\eta_p^2 = .08$ , indicating no significant differences in invalid target detection RT between the horizontal meridian enhancement condition ( $M = 167.58$  ms,  $SEM = 4.21$  ms), the vertical meridian enhancement condition ( $M = 160.63$  ms,  $SEM = 4.51$  ms), and the no meridian enhancement condition ( $M = 176.69$  ms,  $SEM = 4.59$  ms). This main effect was further qualified by a significant two-way interaction,  $F(2,54) = 5.48$ ,  $p = .007$ ,  $\eta_p^2 = .17$ .

The interaction between Shift Direction and Meridian describes the significant differences in the magnitude of the SDA as a function of meridian emphasis (See Fig. 26). For all meridian conditions, paired samples  $t$ -tests revealed a significant SDA, such that reallocating object-based attention horizontally (horizontal meridian enhancement:  $M = 148.56$  ms,  $SEM = 4.40$  ms; vertical meridian enhancement:  $M = 124.78$  ms,  $SEM = 5.57$  ms; no meridian enhancement:  $M = 143.65$  ms,  $SEM = 6.21$  ms) was significantly faster than reallocating vertically (horizontal meridian enhancement:  $M = 186.61$  ms,  $SEM = 4.40$  ms; vertical meridian enhancement:  $M = 196.48$  ms,  $SEM = 5.57$  ms; no meridian enhancement:  $M = 209.74$  ms,  $SEM = 6.21$  ms), all  $t_s > 4.3$ , all  $p_s < .001$ . Thus, a horizontal advantage SDA was observed when the horizontal meridian (38.05 ms) and vertical meridian (71.70 ms) were emphasized. The SDA observed from the vertical meridian enhancement condition was not significantly different than the SDA observed from the no meridian enhancement control (66.10 ms),  $t(27) = 0.56$ ,  $p = .578$ ,  $d = 0.09$ ; however, the SDA observed from the horizontal meridian condition was significantly smaller than the SDA from the vertical meridian condition,  $t(27) = 3.18$ ,  $p = .004$ ,  $d = 0.63$ , as well as the SDA from the no meridian condition,  $t(27) = 2.32$ ,  $p = .028$ ,  $d = 0.49$ .

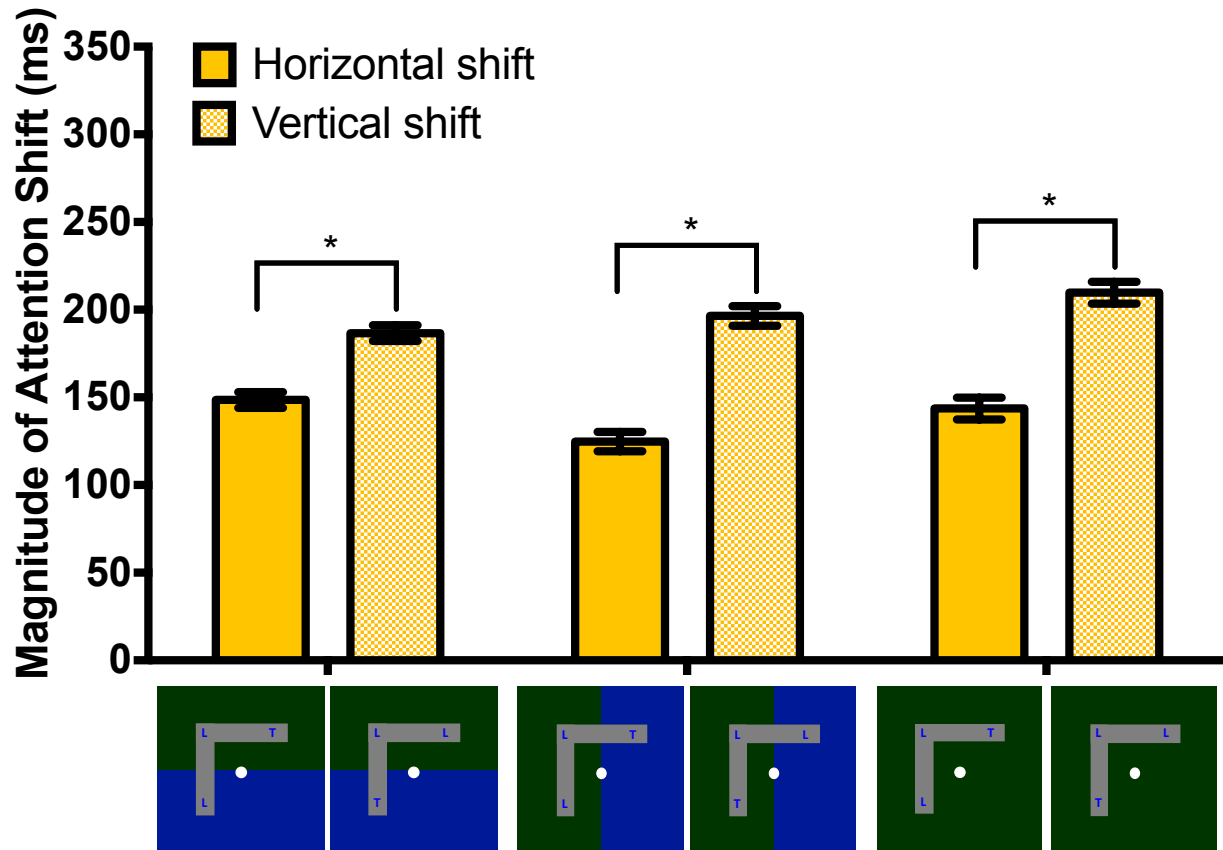

**Figure 26. Mean response latencies in Experiment 8 (Colored background hemifields).** “Magnitude of Attention Shift” measured for the Shift Direction x Meridian interaction in Experiment 8. The error bars represent the standard error of the mean for within-subjects design. *Note.* Meridian conditions include opposing color representations (i.e., blue upper and green lower hemifields, blue left and green right hemifields, and all blue hemifield, respectively)

Additional analyses of the two-way interaction revealed a significant simple effect of Meridian on invalid-horizontal shift RTs,  $F(2,54) = 3.33, p = .043, \eta_p^2 = .11$ , such that reallocating attention horizontally was significantly faster in the vertical meridian enhancement condition than in the horizontal meridian enhancement condition,  $t(27) = 2.50, p = .019, d = 0.35$ . Invalid-horizontal shift RTs in the horizontal and vertical meridian enhancement conditions did not differ from the no meridian enhancement control, all  $ts < 2$ , all  $ps > .08$ . The simple effect of Meridian on invalid-vertical shift RTs was also significant,  $F(2,54) = 3.25, p = .046, \eta_p^2$

= .11. Invalid-vertical shift RTs were significantly faster in the horizontal meridian enhancement condition than in the no meridian enhancement condition,  $t(27) = 2.35, p = .026, d = 0.31$ . There were no differences between the vertical meridian enhancement condition and the horizontal or no meridian enhancement conditions, all  $ts < 1.6$ , all  $ps > .14$ .

When all 31 participants were included, a similar main effect of Shift Direction was observed,  $F(1,30) = 50.17, p < .001, \eta_p^2 = .63$ , as well as a significant two-way interaction,  $F(2,60) = 3.46, p = .038, \eta_p^2 = .10$ . However, the main effect of Meridian became marginally significant,  $F(2,60) = 3.04, p = .055, \eta_p^2 = .09$ .

**Error rates.** Mean error rates for each trial condition are reported in Table 7. These values were submitted to a 3 x 3 repeated measures ANOVA with Meridian (horizontal, vertical, none) and Trial Condition (invalid-horizontal, invalid-vertical, and valid) as within-subjects factors. There were no significant main effects or interactions, all  $F_s < 0.2$ , all  $ps > .9$ , nor any significant pairwise comparisons, all  $ts < 1.3$ , all  $ps > .2$ , indicating no statistically significant differences in error rates across trial conditions.

## **Discussion**

The results from Experiment 8 revealed that horizontal shifts of attention across the vertical meridian were significantly faster than vertical shifts of attention across the horizontal meridian, regardless of whether the horizontal meridian or vertical meridian was emphasized with different colored background hemifields. Importantly, though, the SDA was significantly smaller when the horizontal meridian was enhanced compared to when the vertical meridian was enhanced, providing additional evidence that a high local feature contrast manipulation on the horizontal meridian is capable of modulating the SDA and that the horizontal meridian plays a critical role in producing anisotropic attention shifts. However, enhancing the horizontal

meridian with this particular manipulation did not fully eliminate the SDA altogether, suggesting that enhancing the meridians with colored background hemifields is not as strong as enhancing the meridians with white visible lines, as in Experiments 6 and 7 and that the SDA is only affected by white visible lines.

In order to fully understand the extent that manipulating the local feature contrast of the meridians has on the SDA, low local feature contrast manipulations (i.e., using line gratings to create an illusory line and emphasizing the ends of the meridians) were carried out in the next two experiment.

### **Experiment 9: Low local feature contrast manipulation with an illusory contour**

The goal of Experiment 9 was to examine whether an illusory contour modulates the magnitude of the SDA. Although a physical line is not present, one perceives a straight illusory line at the juxtaposition of two offset line gratings. Since the meridians themselves are invisible, we wondered if a perceptually visible illusory line could have the same effect on the SDA as a visible line. Similar to Experiment 6, we believed that an illusory horizontal meridian would reduce the magnitude of the SDA but, in light of our observations reported above, would not be strong enough to fully eliminate the difference between horizontal and vertical shifts. We also believed that an illusory vertical meridian would have no effect on modulating the SDA, as has been previously demonstrated. These results would support the idea that the SDA is susceptible to perceptually strong enhancements and is relatively unaffected by perceptually weaker enhancements.

### **Method**

All aspects of Experiment 9 were identical to those of Experiment 6, except as described below.

**Participants.** Thirty-one new individuals from the University of Wisconsin-Milwaukee and surrounding community ( $M_{\text{age}} = 21.94$  years,  $SD_{\text{age}} = 4.28$  years; 25 women, 6 men) participated in this experiment.

**Apparatus, stimuli, design, and procedure.** Visual field meridians were emphasized using illusory contours derived from abutting line gratings (See Fig. 17; See Soriano, Spillmann, & Bach, 1995). Line gratings for the horizontal meridian consisted of 32 white vertical lines, each  $0.17^\circ \times 15.15^\circ$  with a phase angle of  $180^\circ$ <sup>2</sup>, resulting in 16 lines in the upper visual field and 16 lines in the lower visual field. Individual line gratings were spaced  $1.1^\circ$  apart with  $0^\circ$  alignment along the horizontal meridian<sup>3</sup>. These parameters were also used for the vertical meridian, except horizontal lines were  $15.15^\circ \times 0.17^\circ$ , there were 16 lines in the left visual field and 16 lines in the right visual field and were aligned  $0^\circ$  along the vertical meridian. Importantly, no lines appeared on the meridians in order to allow for an uninterrupted percept of an illusory line along the entire length of a meridian. A no meridian emphasis condition without abutting line gratings served as a baseline control.

## Results

**Data quality.** The original sample of 31 participants had a mean false alarm rate of 9% ( $SD = 8\%$ ) and a mean miss rate of 3% ( $SD = 2\%$ ). Using the same exclusion criteria from Experiment 1, a total of 3 participants with an excessively high false alarm rate ( $n = 3$ ;  $M = 28\%$ ,  $SD = 1\%$ ) on catch trials were discarded. This resulted in a final sample of 28 participants ( $M_{\text{age}} = 22.00$  years,  $SD_{\text{age}} = 4.49$  years; 24 women, 4 men) with a mean false alarm rate of 7% ( $SD = 5\%$ ) and a mean miss rate of 3% ( $SD = 2\%$ ). An independent samples  $t$ -test revealed a

---

<sup>2</sup> A value of  $0^\circ$  corresponds to collinearity whereas a value of  $180^\circ$  corresponds to a phase shift of one half cycle and lines appear equally offset.

<sup>3</sup> A positive alignment results in a gap whereas a negative alignment results in an overlap.

significantly larger false alarm rate for the excluded participants compared to the included participants,  $t(17.39) = 17.63, p < .001, d = 5.43$ . Additionally, anticipatory responses (RT less than 200 ms) were discarded.

**Response latencies.** The dependent variable was mean RT for correct responses, reported in Table 6. As in Experiment 1, mean RT differences were calculated by subtracting mean raw RTs to valid targets from mean RTs to invalid-horizontal targets and invalid-vertical targets for each meridian condition. Next, mean RT differences were submitted to a 2 x 3 repeated measures ANOVA with Shift Direction (horizontal, vertical) and Meridian (horizontal, vertical, none) as within-subjects factors. The analysis revealed a main effect of Shift Direction,  $F(1,27) = 29.76, p < .001, \eta_p^2 = .52$ , indicating a significant difference in invalid target detection RT when reallocating object-based attention horizontally ( $M = 251.31$  ms,  $SEM = 6.92$  ms) versus vertically ( $M = 326.86$  ms,  $SEM = 6.92$  ms). The main effect of Meridian, however, was not significant,  $F(2,54) = 0.32, p = .730, \eta_p^2 = .01$ , indicating no significant differences in invalid target detection RT between the horizontal meridian enhancement condition ( $M = 289.35$  ms,  $SEM = 3.31$  ms), the vertical meridian enhancement condition ( $M = 291.66$  ms,  $SEM = 4.36$  ms), and the no meridian enhancement condition ( $M = 286.24$  ms,  $SEM = 4.10$  ms). The two-way interaction was also not significant,  $F(2,54) = 1.94, p = .154, \eta_p^2 = .07$ .

Paired samples  $t$ -tests revealed a significant SDA for each meridian enhancement condition, such that reallocating object-based attention horizontally (horizontal meridian enhancement condition:  $M = 259.14$  ms,  $SEM = 8.81$  ms; vertical meridian enhancement condition:  $M = 249.21$  ms,  $SEM = 6.11$  ms; no meridian enhancement condition:  $M = 245.57$  ms,  $SEM = 8.60$  ms) was significantly faster than reallocating vertically (horizontal meridian enhancement condition:  $M = 319.55$  ms,  $SEM = 8.81$  ms; vertical meridian enhancement

condition:  $M = 334.11$  ms,  $SEM = 6.11$  ms; no meridian enhancement condition:  $M = 326.91$  ms,  $SEM = 8.61$  ms), all  $t_s > 4.3$ , all  $p_s < .001$  (See Fig. 27). Thus, a horizontal advantage SDA was observed regardless of meridian emphasis (horizontal meridian enhancement condition: 60.41 ms; vertical meridian enhancement condition: 84.90 ms; no meridian enhancement condition: 81.34 ms). The SDA observed from the horizontal meridian enhancement condition was marginally smaller than the SDA observed from the vertical meridian enhancement condition,  $t(27) = 1.99, p = .057, d = 0.31$ . No other differences between SDAs were observed, all  $t_s < 1.4$ , all  $p_s > .2$ . Additionally, there were no significant simple effects of meridian condition on invalid target detection RTs or planned comparisons, all  $p_s > .11$ .

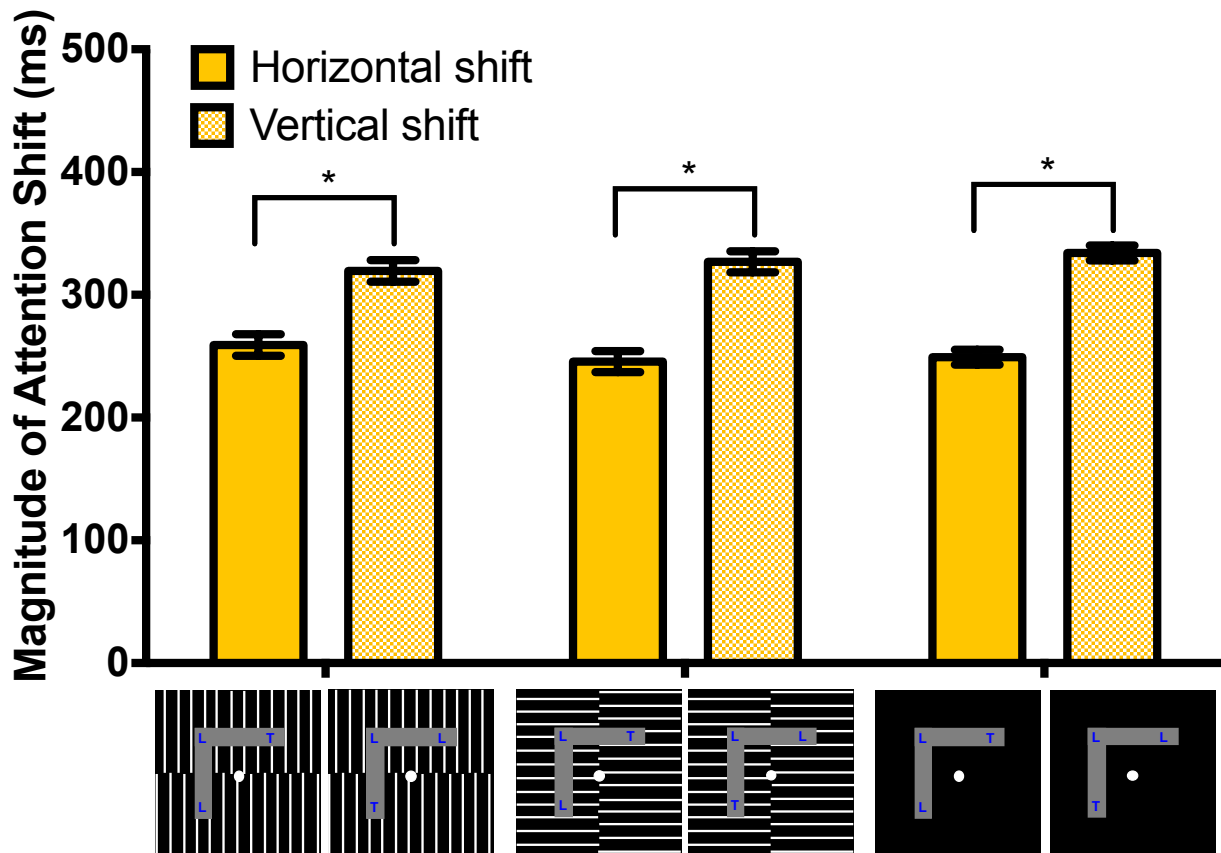

**Figure 27. Mean response latencies in Experiment 9 (Illusory contour).** “Magnitude of Attention Shift” measured for the non-significant Shift Direction x Meridian interaction in Experiment 9. The error bars represent the standard error of the mean for within-subjects design.

When all 31 participants were included, we observed a similar main effect of Shift Direction,  $F(1,30) = 32.59$ ,  $p < .001$ ,  $\eta_p^2 = .52$ , as well as a non-significant main effect of Meridian,  $F(2,60) = 0.25$ ,  $p = .783$ ,  $\eta_p^2 = .01$ . However, a significant two-way interaction emerged,  $F(2,60) = 4.54$ ,  $p = .015$ ,  $\eta_p^2 = .13$ .

**Error rates.** Mean error rates for each trial condition are reported in Table 7. These values were submitted to a 3 x 3 repeated measures ANOVA with Meridian (horizontal, vertical, none) and Trial Condition (invalid-horizontal, invalid-vertical, and valid) as within-subjects factors. There were no significant main effects or interactions, all  $F$ s  $< 2$ , all  $p$ s  $> .12$ , nor any significant pairwise comparisons,  $t$ s  $\geq 1.2$ ,  $p$ s  $\geq .1$ , indicating no statistically significant differences in error rates across trial conditions.

## **Discussion**

The results of Experiment 9 revealed significant shift direction anisotropies when the horizontal and vertical meridians were enhanced by an illusory contour. These results mirror those obtained in Experiment 8 and demonstrate that a horizontal meridian emphasized with something other than a white visible line reduces the magnitude of the SDA but does not fully eliminate it. Though the SDA persisted despite enhancing the horizontal meridian, the results do support the notion that shifting across the horizontal meridian is a causal factor in driving the SDA. When an illusory horizontal meridian was present, the SDA was reduced relative to the magnitude of the SDA observed for an illusory vertical meridian. However, a significant SDA was observed regardless, indicating that the illusory contour was not strong enough to completely eliminate the SDA. By increasing the perceptual visibility of the horizontal meridian, albeit with a weaker manipulation relative to a white visible line, we still see evidence that the

SDA is modulated by the horizontal meridian and is largely unaffected by anything occurring along the vertical meridian.

### **Experiment 10: Low local feature contrast manipulation with meridian ends**

In Experiments 6-9, the full length of a meridian was always emphasized, irrespective of the type and strength of the manipulation. In general, the SDA was eliminated when the entire horizontal meridian was made visible with a line at 100% contrast and was reduced, but not eliminated, with weaker manipulations. This begs the question whether the horizontal meridian's causal role in the SDA is dependent upon perceptually enhancing the whole horizontal meridian or if a similar effect on the SDA is possible when only a portion of the meridian is perceptually enhanced. Thus, in Experiment 10, only the ends of the meridians were enhanced with a visible line in order to determine whether the SDA is susceptible to partial or whole manipulations of the horizontal meridian. We hypothesized that the SDA would be reduced when the ends of the horizontal meridian are enhanced with visible lines and would be unaffected by enhancing the ends of the vertical meridian.

### **Method**

All aspects of Experiment 10 were identical to those of Experiment 6, except as described below.

**Participants.** Thirty-one new individuals from the University of Wisconsin-Milwaukee and surrounding community ( $M_{\text{age}} = 21.52$  years,  $SD_{\text{age}} = 5.49$  years; 25 women, 6 men) participated in this experiment.

**Apparatus, stimuli, design, and procedure.** The ends of the visual field meridians were emphasized with a visible line at 100% contrast (See Fig. 17). Visible end segments on the horizontal meridian were  $16.25^\circ \times 0.17^\circ$  extending inward from the edge of the screen, whereas

visible end segments on the vertical meridian were  $0.17^\circ \times 16.25^\circ$  extending inward from the edge of the screen. The ends the meridians were  $2.0^\circ$  away from the nearest edge of the 'L'-shaped object. A no meridian emphasis condition without visible ends served as a baseline control.

## Results

**Data quality.** The original sample of 31 participants had a mean false alarm rate of 9% ( $SD = 7\%$ ) and a mean miss rate of 4% ( $SD = 4\%$ ). Using the same exclusion criteria from Experiment 1, a total of 3 participants with an excessively high false alarm rate ( $n = 2$ ;  $M = 29\%$ ,  $SD = 5\%$ ) on catch trials and/or number of misses ( $n = 1$ ;  $N = 177$  trials) on target-present trials were discarded. This resulted in a final sample of 28 participants ( $M_{age} = 21.75$  years,  $SD_{age} = 5.74$  years; 22 women, 6 men) with a mean false alarm rate of 8% ( $SD = 5\%$ ) and a mean miss rate of 3% ( $SD = 3\%$ ). An independent samples  $t$ -test revealed no significant difference between false alarm rates for the excluded participants compared to the included participants,  $t(1.15) = 5.95$ ,  $p = .084$ ,  $d = 4.34$ . Additionally, anticipatory responses (RT less than 200 ms) were discarded.

**Response latencies.** The dependent variable was mean RT for correct responses, reported in Table 6. As in Experiment 1, mean RT differences were calculated by subtracting mean raw RTs to valid targets from mean RTs to invalid-horizontal targets and invalid-vertical targets for each meridian condition. Next, mean RT differences were submitted to a 2 x 3 repeated measures ANOVA with Shift Direction (horizontal, vertical) and Meridian (horizontal, vertical, none) as within-subjects factors. The analysis revealed a main effect of Shift Direction,  $F(1,27) = 42.62$ ,  $p < .001$ ,  $\eta_p^2 = .61$ , indicating a significant difference in invalid target detection RT when reallocating object-based attention horizontally ( $M = 258.09$  ms,  $SEM = 5.29$  ms) versus

vertically ( $M = 327.11$  ms,  $SEM = 5.29$  ms). The main effect of Meridian, however, was not significant,  $F(2,54) = 0.58$ ,  $p = .564$ ,  $\eta_p^2 = .02$ , indicating no significant difference in invalid target detection RT between the horizontal meridian enhancement condition ( $M = 287.92$  ms,  $SEM = 4.17$  ms), the vertical meridian enhancement condition ( $M = 293.66$  ms,  $SEM = 5.10$  ms), and the no meridian enhancement condition ( $M = 296.23$  ms,  $SEM = 4.38$  ms). The two-way interaction was also not significant,  $F(2,54) = 0.28$ ,  $p = .759$ ,  $\eta_p^2 = .01$ .

Paired samples  $t$ -tests revealed a significant SDA for each meridian enhancement condition, such that reallocating object-based attention horizontally (horizontal meridian enhancement condition:  $M = 253.93$  ms,  $SEM = 6.27$  ms; vertical meridian enhancement condition:  $M = 256.34$  ms,  $SEM = 6.58$  ms; no meridian enhancement condition:  $M = 263.99$  ms,  $SEM = 7.03$  ms) was significantly faster than vertically (horizontal meridian enhancement condition:  $M = 321.90$  ms,  $SEM = 6.27$  ms; vertical meridian enhancement condition:  $M = 330.98$  ms,  $SEM = 6.58$  ms; no meridian enhancement condition:  $M = 328.46$  ms,  $SEM = 7.03$  ms), all  $t$ s  $> 4.5$ , all  $p$ s  $< .001$  (See Fig. 28). Thus, a horizontal advantage SDA was observed regardless of meridian emphasis (horizontal meridian enhancement condition: 67.97 ms; vertical meridian enhancement condition: 74.64 ms; no meridian enhancement condition: 64.47 ms). No significant differences between SDAs were observed, all  $t$ s  $< 0.7$ , all  $p$ s  $> .5$ . Additionally, there were no significant simple effects of meridian condition on invalid target detection RTs or planned comparisons, all  $p$ s  $> .29$ .

When all 31 participants were included, we observed a similar main effect of Shift Direction,  $F(1,29) = 43.12$ ,  $p < .001$ ,  $\eta_p^2 = .60$ . The main effect of Meridian and the two-way interaction were not significant, all  $F$ s  $< 0.9$ , all  $p$ s  $> .4$ .

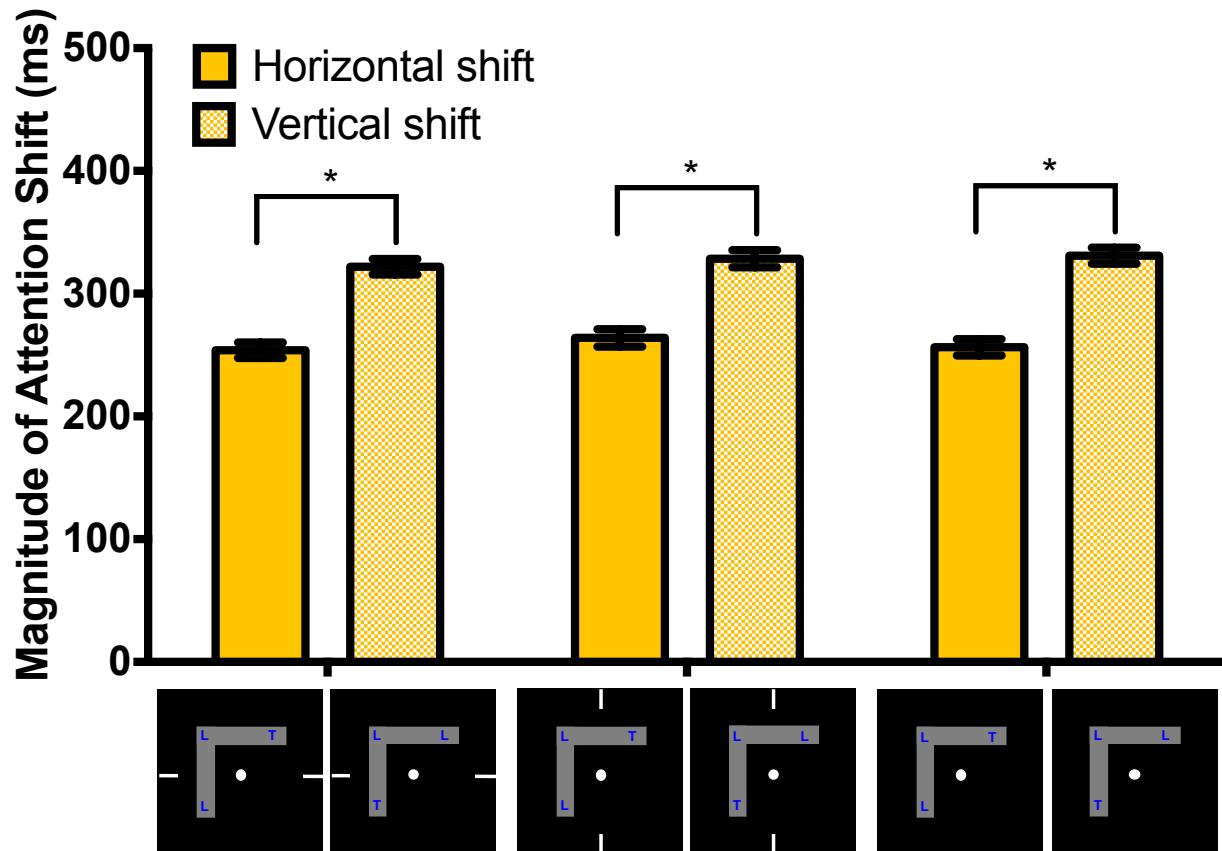

**Figure 28. Mean response latencies in Experiment 10 (Meridian ends).** “Magnitude of Attention Shift” measured for the non-significant Shift Direction x Meridian interaction in Experiment 10. The error bars represent the standard error of the mean for within-subjects design.

**Error rates.** Mean error rates for each trial condition are reported in Table 7. These values were submitted to a 3 x 3 repeated measures ANOVA with Meridian (horizontal, vertical, none) and Trial Condition (invalid-horizontal, invalid-vertical, and valid) as within-subjects factors. There were no significant main effects or interactions, all  $F_s < 0.6$ , all  $p_s > .5$ , nor any significant pairwise comparisons,  $t_s \geq 1.1$ , all  $p_s \geq .2$ , indicating no statistically significant differences in error rates across trial conditions.

## **Discussion**

As expected, emphasizing only the ends of the meridians had no effect on reducing or eliminating the SDA. Horizontal shifts of attention were significantly faster than vertical shifts of attention regardless of whether the horizontal or vertical meridian was enhanced. Additionally, unlike the other manipulations reported above, there was no difference in the magnitude of the SDA between horizontal and vertical meridian enhancement conditions, demonstrating that the SDA is not at all affected by this type of manipulation. Importantly, though, this finding indicates that partial enhancements of the meridians have no effect and that any reductions of the SDA will likely occur when the entire horizontal meridian is enhanced.

### **General Discussion**

Our previous work demonstrated that crossing the visual field meridians produces an anisotropy between horizontal and vertical shifts of object-based attention, which were faster horizontally than vertically. This general finding suggests a critical modulatory role of the meridians in the reorienting of object-based attention. The goal of this chapter was to explicitly test the causal role of the meridians by manipulating their perceptual visibility in order to determine whether emphasizing the horizontal and/or vertical meridian impacted the SDA. Observing a change in the magnitude of the SDA after enhancing a meridian would indicate the importance of that meridian in the emergence of the SDA. Emphasizing the meridians was accomplished by increasing the local feature contrast of the meridian with both high/strong manipulations (i.e., visible lines and colored background hemifields) and low/weak manipulations (i.e., illusory contours and meridian ends). The results of Experiments 6-10 (except Experiment 7) are summarized in Figure 29.

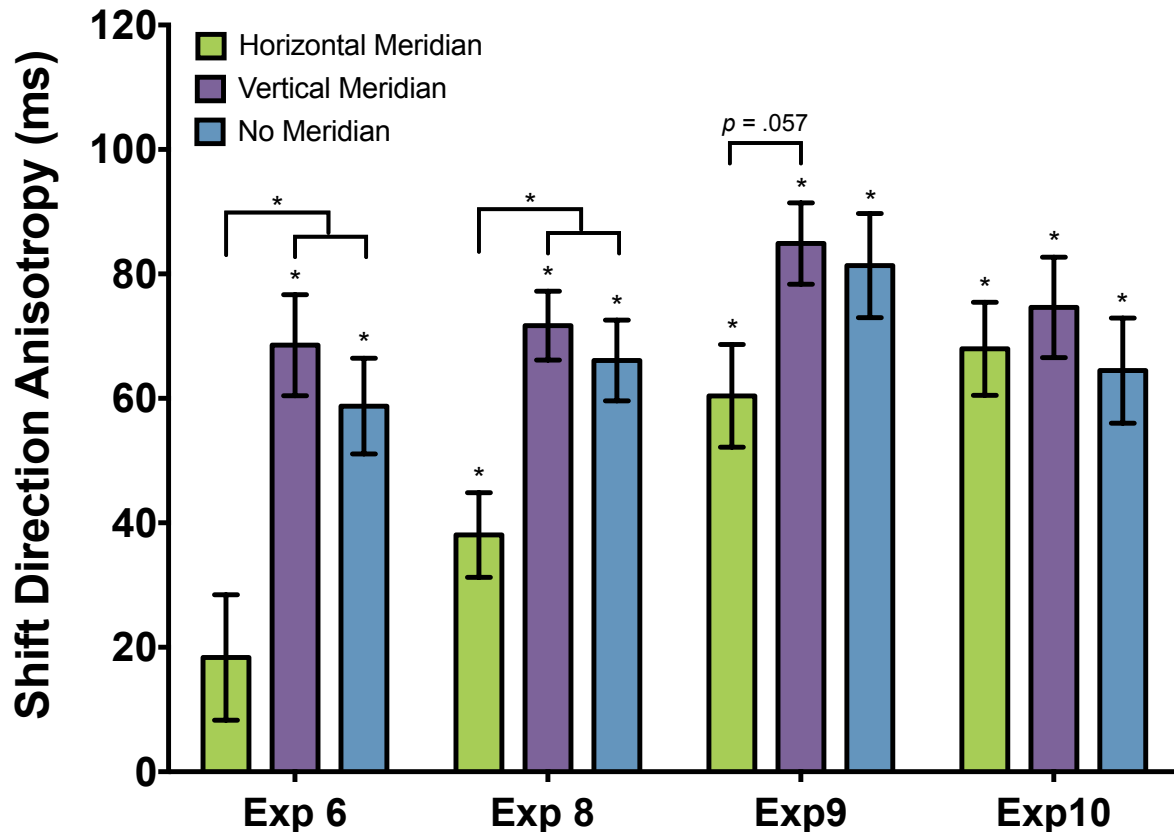

**Figure 29. Shift direction anisotropies across Experiments 6-10 (Excluding Experiment 7).** Shift direction anisotropies were calculated by subtracting RT difference for invalid-horizontal target location from RT difference for invalid vertical target location for each meridian condition. Positive values indicate a horizontal shift advantage (invalid-horizontal RT < invalid-vertical RT). The error bars represent the standard error of the mean for within-subjects designs. Unless indicated, asterisks indicate significant shift direction anisotropies (significant difference from zero; all  $ps \leq .05$ )

In Experiment 6, visual field meridians were enhanced with white visible lines. When the vertical meridian was enhanced, we observed a significant SDA that was not significantly different than the SDA obtained without an enhanced meridian. However, we did not observe a significant SDA when the horizontal meridian was enhanced. Thus, the SDA was eliminated when the perceptual visibility of the horizontal meridian was enhanced with a high local feature contrast manipulation. The results of Experiment 7 are summarized in Figure 25. In this

experiment, visual field meridians were enhanced with visible lines of varying contrasts. Similar to Experiment 6, a significant shift direction anisotropy was observed whenever the vertical meridian was enhanced, regardless of the contrast value of the visible vertical line. The magnitudes of these SDAs were not significantly different than the SDA obtained from a no meridian enhancement baseline, although the SDA was rather large with a 100% contrast vertical line. Significant anisotropies were also observed for a perceptually enhanced horizontal meridian with a 33% and 66% contrast line. The magnitudes of these SDAs were smaller than the baseline control but were not significantly different. Importantly, we were able to replicate our result from Experiment 6 in which a horizontal meridian enhanced with a 100% contrast line eliminated the SDA. We were able to successfully replicate the pattern of results obtained in Experiment 6 which indicates that the SDA is a stable metric across experiments and is sensitive to strong perceptual enhancements of the horizontal meridian. Additionally, the results from Experiment 7 suggest that the contrast value of the visible line is an important factor in modulating the SDA – the SDA is unaffected by low contrast horizontal lines and is greatly affected by high contrast horizontal lines.

To further explore the role of the meridians on the SDA, in Experiment 8 we enhanced the meridians with another strong local feature contrast manipulation by using different colored background hemifields. Similar to Experiments 6 and 7, we found that when the perceptual visibility of the vertical meridian was emphasized, a significant SDA emerged that was not significantly different from the SDA obtained without enhancing the meridians. But, contrary to the finding from Experiments 6 and 7, a significant SDA also emerged when the horizontal meridian was enhanced. The magnitude of the SDA from the horizontal meridian enhancement condition, however, was significantly reduced compared to the SDAs observed from the vertical

meridian and no meridian enhancement conditions. Together, these results indicate that the SDA is sensitive to strong manipulations of the meridian local feature contrast and that the horizontal meridian, in particular, is important in the emergence of the SDA.

In Experiments 9 and 10, visual field meridians were enhanced by creating illusory contours at the meridians and highlighting the ends of the meridians, respectively. In both experiments, a significant SDA emerged when the vertical meridian was enhanced, which did not vary significantly from the SDA obtained from the no meridian enhancement condition. Significant SDAs also emerged for both horizontal enhancement conditions. In Experiment 9, the SDA observed in the horizontal meridian enhancement condition was marginally reduced than the SDA obtained from the vertical meridian enhancement condition. There were no differences among the three SDAs in Experiment 10.

Emphasizing the perceptual visibility of the horizontal meridian can selectively reduce, and in some circumstances eliminate, anisotropic attention shifts, depending on the strength of the meridian emphasis. The SDA was eliminated when the horizontal meridian was enhanced with a strong local feature contrast manipulation (i.e., visible line at 100% contrast), and was reduced, but not fully eliminated, with a weak local feature contrast manipulation (i.e., colored background hemifields and illusory lines). Increasing the perceptual visibility of the vertical meridian had no effect on ameliorating the SDA. In summary, these findings demonstrate that the SDA is (1) sensitive to strong manipulations of the meridians, but not weaker ones, and (2) emerges due to crossings of the horizontal meridian.

An important point to consider, however, is what occurs in order to eliminate the SDA. The SDA is characterized by faster RTs when shifting attention horizontally versus vertically. Three scenarios are possible in order to equate horizontal and vertical shifts of attention: (1)

vertical attention shift RTs get faster while horizontal attention shift RTs remain unchanged, (2) horizontal attention shifts get slower while vertical attention shift RTs remain unchanged, or (3) vertical attention shift RTs get faster while horizontal attention shifts get slower. In Experiment 6, when the SDA was eliminated with a visible horizontal meridian, there was a non-significant trend of both faster vertical attention shift RTs and slower horizontal attention shift RTs, relative to the RTs with a visible vertical meridian (See Fig. 30). This pattern of RTs was also observed in Experiment 7, when the SDA was eliminated with a 100% contrast line on the horizontal meridian. Moreover, even when the SDA was reduced but still significant, as in Experiments 8 and 9, there was a trend for faster vertical attention shift RTs and slower horizontal attention

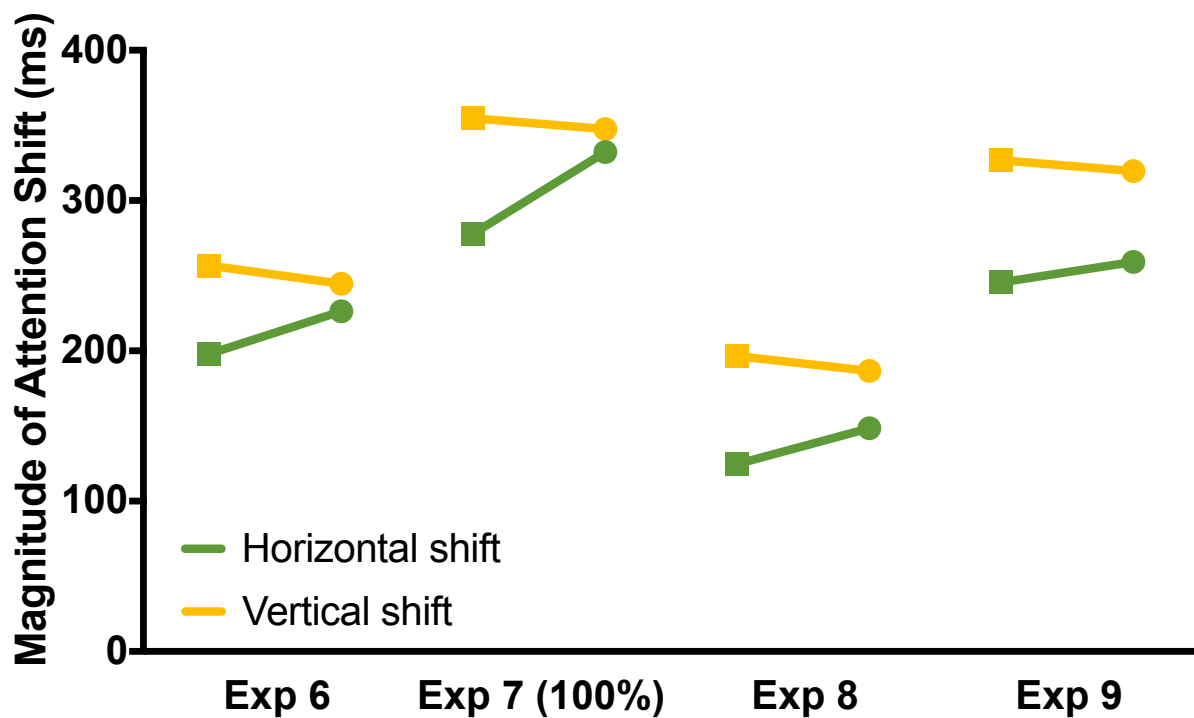

**Figure 30. Shift direction RTs affected by meridian enhancements.** “Magnitude of attention shift” measured for each direction and meridian enhancement for Experiments 6-9. Squares denote RTs recorded from vertical meridian conditions; Circles denote RTs recorded from horizontal meridian conditions. Across all experiments, reduction in SDA magnitude during horizontal meridian enhancements was associated with simultaneous trends for faster vertical shift RTs and slower horizontal shift RTs, relative to shift RTs in vertical meridian enhancements.

shift RTs. Thus, perceptual enhancements of the horizontal meridian reduce the magnitude of the SDA by simultaneously increasing the speed at which vertical attention shifts cross the horizontal meridian and decreasing the speed at which horizontal attention shifts cross the vertical meridian.

To account for the observed modulation of the SDA, we theorize that emphasizing the horizontal meridian may result in an “artificial boundary” that further subdivides and sequesters attentional resources into independent pools within each cerebral hemisphere. It is well-established that the left and right cerebral hemispheres have independent attentional capabilities (Alvarez & Cavanagh, 2005; Clewenger & Beck, 2014). Therefore, emphasizing the vertical meridian may have had little effect in reducing the SDA because of the anatomical segregation (i.e., the interhemispheric boundary along the vertical meridian) that exists between the two hemispheres. In fact, emphasizing the vertical meridian may make the boundary between the hemispheres more distinct, leading to an increased difference between horizontal and vertical shifts. As we observed in Experiment 7, horizontal attention shift RTs greatly sped up when the vertical meridian was enhanced with a 100% contrast line. To account for the observed elimination of the SDA as a result of emphasizing the horizontal meridian, however, we believe that a perceptually visible horizontal meridian establishes an artificial intrahemispheric boundary within each hemisphere that further subdivides and sequesters attentional resources into four distinct pools. As a result, competition for attentional resources along the vertical meridian is reduced, thus equating horizontal and vertical attention shift RTs and ameliorating the SDA.

## **CHAPTER 5: What Are the Neural Correlates of the Shift Direction**

### **Anisotropy?**

In Chapter 3, we observed a significant shift direction anisotropy between horizontal and vertical shifts of object-based attention whenever invalid target locations crossed the visual field meridians. There were no differences between horizontal and vertical shifts of object-based attention when invalid target locations did not cross the meridians. Together, these results suggest that the location of the invalid targets are what drive the emergence of the SDA. Since horizontal and vertical targets were always equidistant from the peripheral cue and one object was always available for attentional selection, RTs to both target locations, presumably, should have been equivalent. However, there is a dissociation for invalid target locations that cross the meridians compared to invalid target locations that do not cross the meridians.

The neuroanatomy of the visual system may contribute to this performance difference. The left and right cerebral hemispheres are organized contralaterally, imposing an interhemispheric boundary along the vertical meridian (anatomically speaking, the longitudinal fissure). Therefore, shifting attention horizontally from a cued location (e.g., in the upper left) to an invalidly cued location (in the upper right) may experience faster RTs because each target location (valid and invalid-horizontal, respectively) is represented within a separate hemisphere and has the benefit of receiving all of the attentional resources from that particular hemisphere. Alternatively, shifting attention vertically from a cued location to an invalidly cued location (now, in the lower left) may experience slower RTs because both target locations are represented by only one hemisphere, thus sharing and dividing the pool of available resources. This theory fits well with evidence from attentional tracking (Alvarez & Cavanagh, 2005) and visual search

(Clevenger & Beck, 2014) demonstrating independent capabilities between the hemispheres during these kinds of tasks.

### **Experiment 11: Elucidating the neural correlates of the shift direction anisotropy**

The shift direction anisotropy is a stable and consistent metric of object-based attention that has been observed numerous times in behavioral RT measures. The goal of this experiment was to directly test the theory that shifts of attention are impaired across the intrahemispheric boundary (horizontal meridian) versus the interhemispheric boundary (vertical meridian) by imaging the effects of the shift direction anisotropy in sensory visual cortex. We measured task-evoked functional neural activity (via blood flow signals) when shifting attention across the interhemispheric and intrahemispheric boundaries and compared those activation differences to attention shifts that do not cross these boundaries. Generally, the hypothesis is that neural activation in response to the cue (i.e., cue-related activity) or target (i.e., target-related activity) would reflect the attentional resources afforded to the retinotopic locations in line with the behavior. We expected to find that blood oxygen level-dependent (BOLD) signal would be significantly different when reallocating attention to invalid-horizontal targets that crossed the interhemispheric boundary versus to invalid-vertical targets that crossed the intrahemispheric boundary. Additionally, we expected to find that BOLD signal would be statistically equivalent when reallocating attention to invalid-horizontal targets that did not cross the interhemispheric boundary compared to invalid-vertical targets that did not cross the intrahemispheric boundary.

### **Method**

**Participants.** Ten neurologically healthy volunteers ( $M_{\text{age}} = 28.4$  years,  $SD_{\text{age}} = 7.60$  years; 7 women, 3 men) from the University of Wisconsin-Milwaukee (UWM) and surrounding community participated in this experiment. All participants indicated having normal or

corrected-to-normal vision and no contraindications for MRI scanning or claustrophobia. Volunteers were paid an hourly pay rate of \$25 as compensation for their participation. This study was approved by the Institution Review Boards at UWM and the Medical College of Wisconsin (MCW).

**Apparatus.** Magnetic resonance imaging was completed on a GE Premier 3 Tesla MRI scanner at MCW. Stimulus presentation was controlled by a laptop using the Psychophysics Toolbox extensions (Brainard, 1997; Pelli, 1997) in the GNU Octave software platform (Bateman et al., 2015) that was triggered by the scanner. All visual stimuli were presented on an 80.01 cm LED projection screen at the rear of the scanner bore and was visible by a head-coil (48 channel) mounted mirror. The screen resolution was 1920 x 1080. A fiber-optic response box was used to record button presses. We acquired a T1-weighted anatomical image [repetition time (TR): 4.8 s; echo time (TE): 1.7s; flip angle: 8°; 340 axial slices; voxel size: 4mm<sup>3</sup>] and measured BOLD fMRI signal using a T2\*-weighted EPI sequence [TR: 1.5s; TE: 33.5 s; flip angle 50°; voxel size 8mm<sup>3</sup>].

### **Experimental task.**

**Stimuli.** As shown in Figure 31, participants viewed a single median gray object (RGB: [128 128 128]) that consisted of a vertical rectangle (2.0° x 14.0°) conjoined at a 90-degree angle with a horizontal rectangle (14.0° x 2.0°), forming a unified ‘L’-shaped object, on a black background. While participants fixated centrally on a white fixation cross (0.2° x 0.2°) of a fixed-width font (Monaco, font size 20), the object vertex was randomly positioned, on a trial-by-trial basis, in one of two screen quadrants (the upper left or lower right) such that the boundaries of one object component always crossed the vertical meridian and the boundaries of the other object component always crossed the horizontal meridian (nearest edge was 2.67°

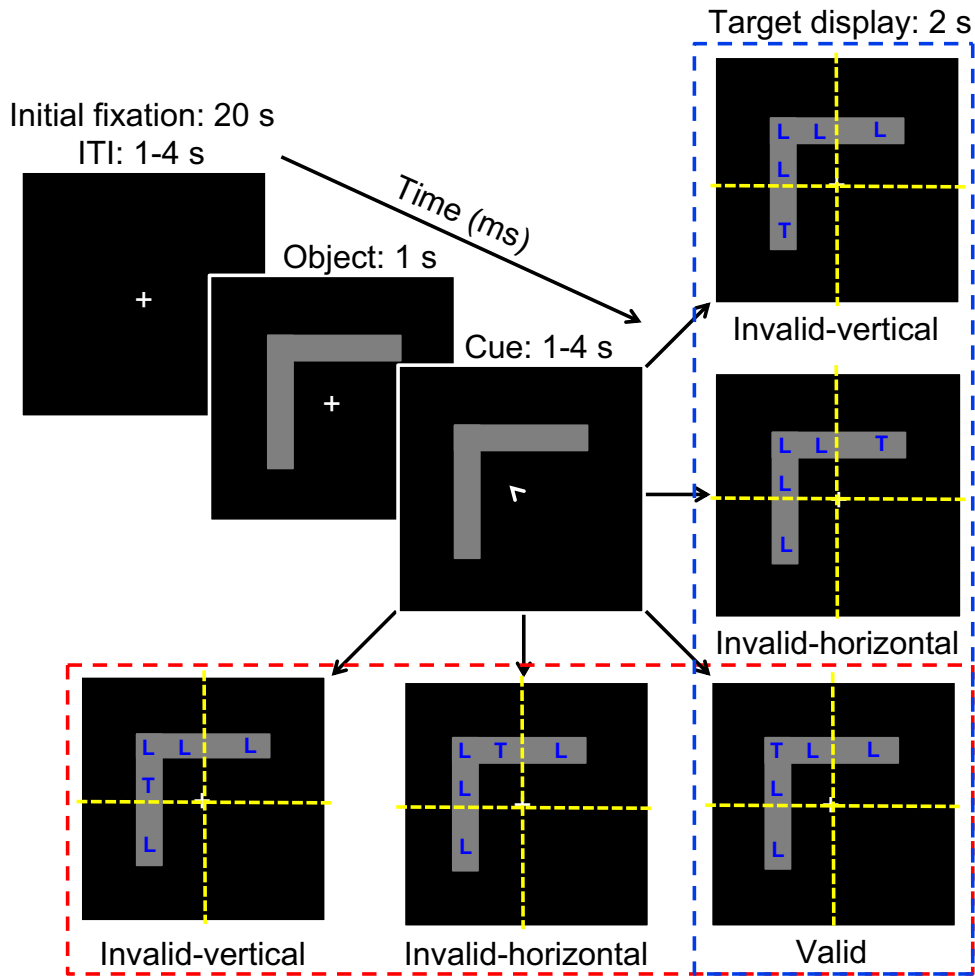

**Figure 31. Trial sequence for Experiment 11 (fMRI Experiment).** Upper left object depicted. Trial conditions were defined by the location of the blue target ‘T’ in relation to the central arrow cue for invalid target locations that crossed the meridians (dashed blue outline) and or did not cross the meridians (dashed red outline).

*Note:* Dotted yellow lines represent the horizontal and vertical meridians and were not visible to participants during the experiment. Not drawn to scale.

above or below the horizontal meridian and  $2.67^\circ$  to the left or right of the vertical meridian, depending on the location of the object’s vertex on the screen). The ‘L’-shaped object was centered on the screen and around the central fixation cross, such that the distances between the vertical screen meridian to the inner edge of the vertical component rectangle and between the

horizontal screen meridian to the inner edge of the horizontal component rectangle were both  $9.3^\circ$ .

A white arrow cue was used and replaced the central fixation cross during a trial. The cue was displayed in 20-point Monaco font and was angled  $45^\circ$  to the upper left or lower right, corresponding to the location of the object. Though 100% predictive, the cue still served to guide spatial attention to the object vertex and selection of the 'L'-shaped object due to the randomization of object location from trial-to-trial.

The target array consisted of blue letters (RGB: [0 0 255]; Monaco, font size 20) subtending  $0.67^\circ$  in length and width and consisted of a single target (the letter 'T') among four non-targets (the letter 'L'). One letter of the target display always appeared in the vertex of the object. The remaining four letters were centered left-to-right within the vertical component rectangle and top-to-bottom within the horizontal component rectangle. Two letters were positioned so that their centers were  $1.0^\circ$  from the near end of either component rectangle thus requiring a shift of attention across the meridians, while the other two letters were positioned so that their centers were  $4.33^\circ$  from the near end of either component rectangle thus not requiring a shift of attention across the meridians. Target and non-target letters on the vertical component rectangle and the horizontal component rectangle for any given 'L'-shaped object were equidistant from the peripheral cue at the object vertex.

Based on the data reported in Experiments 1-3B, a significant SDA emerged when invalid target locations crossed the meridians and did not emerge when invalid target locations did not cross the meridians, regardless of object crossings. Thus, this experimental task would, ideally, allow for the concurrent observation of both significant (crossing invalid targets) and

non-significant (non-crossing invalid targets) shift direction anisotropies without direct manipulations of the object crossings.

**Design.** fMRI data were acquired in one 2-hr testing session. The manipulated within-subjects factors were Target Array (crossing, non-crossing), Object Location (upper left, lower right), and Validity (valid, invalid-horizontal, invalid-vertical). Object Location and Validity varied randomly within runs. Target Array was blocked (i.e., varied across runs), such that a given run contained all non-crossing invalid targets or all crossing invalid targets. Four runs of each target array condition were completed, for a total of 8 runs. Each run contained 60 trials and lasted 507 s. For each Target Array condition, the following three trial types were defined by the location of the target ‘T’ at: (1) the cued location at the object vertex (valid condition), (2) the non-cued location of the object’s horizontal component rectangle (invalid-horizontal condition), or (3) the non-cued location of the object’s vertical component rectangle (invalid-vertical condition). Non-targets (‘L’) also appeared, as placeholders, on the object in the locations that did not contain the target letter. If the target array was Crossing, non-targets would always appear at the non-crossing target locations. Conversely, if the target array was Non-crossing, non-targets would always appear at the crossing target locations. Thus, regardless of Target Array condition, the number of letters in the target array and, therefore, number of visual stimuli was equivalent on all trials throughout the experiment. Each run consisted of 60% valid trials, 10% invalid-horizontal trials, 10% invalid-vertical trials, and 20% “catch trials”. These proportions were split evenly between both Object Location conditions, such that each object was allotted an equivalent number of trials (e.g., 18 valid trials per block for the upper left object and lower right object).

**Procedure.** Before beginning the experiment, participants were instructed to maintain fixation on the central cross present throughout each trial. As shown in Figure 23, each run began and ended with a 20 s fixation display. Trials began with the presentation of a central fixation cross and one ‘L’-shaped object for 1000 ms. The fixation cross was then replaced by the centrally presented arrow cue that pointed to the vertex of the ‘L’-shaped object. The cue remained for 1000-4000 ms after which the target array appeared. The target letter (‘T’) randomly appeared in one of the three possible locations depending on the Target Array condition (excluding catch trials). Participants performed a detection task (RTs were recorded) and were instructed to respond as quickly and accurately as possible to the presence of the target letter while minimizing false alarms on catch trials and misses on target-present trials. The target array remained on the screen for 2000 ms or until a response was detected, at which point a black screen appeared for the remaining time. The subsequent trial began following a randomly selected inter-trial interval of 1000-4000 ms.

**Pilot study.** All of our previous experiments that utilized one object had a target display that consisted of only 3 target locations and utilized a red peripheral cue. This imaging experiment is the first in which targets can appear in 5 possible locations on one object and that includes a central arrow cue so that activity at validly cued locations at the object vertex can be analyzed. Therefore, a pilot study was conducted prior to this experiment to assess whether both significant and non-significant SDAs can be obtained simultaneously within the same paradigm with a central arrow cue. Data were obtained from a sample of 15 participants who would not complete the MRI experiment ( $M_{\text{age}} = 22.60$  years,  $SD_{\text{age}} = 6.20$  years; 11 women, 4 men). The sample had a mean false alarm rate of 7% ( $SD = 7\%$ ) and mean miss rate of 3% ( $SD = 3\%$ ). Mean RT differences were calculated by subtracting mean raw RTs to valid targets from mean

RTs to invalid-horizontal targets and invalid-vertical targets and submitted to a 2 x 2 repeated measures ANOVA, with Shift Direction (horizontal, vertical) and Target Array (crossing, non-crossing) as within-subjects factors. The analysis revealed a main effect of Shift Direction,  $F(1,14) = 46.77, p < .001, \eta_p^2 = .77$ , indicating a significant difference in invalid target detection RT when reallocating object-based attention horizontally ( $M = 197.59$  ms,  $SEM = 6.46$  ms) versus vertically ( $M = 270.20$  ms,  $SEM = 6.46$  ms). There was also a main effect of Target Array,  $F(1,14) = 31.54, p < .001, \eta_p^2 = .70$ , indicating a significant difference in invalid target detection RT when reallocating object-based attention to invalid targets that crossed the meridians ( $M = 351.64$  ms,  $SEM = 17.22$  ms) versus to invalid targets did not cross the meridians ( $M = 116.15$  ms,  $SEM = 17.22$  ms). These main effects were qualified by a significant interaction,  $F(1,14) = 5.58, p = .033, \eta_p^2 = .29$ .

When the results are partitioned by object location (See Fig. 32), we observed, for the upper left object, a significant horizontal advantage SDA for the crossing invalid targets (horizontal shifts:  $M = 299.44$  ms,  $SEM = 19.20$  ms; vertical shifts:  $M = 428.83$  ms,  $SEM = 19.20$  ms),  $t(14) = 3.37, p = .005, d = 0.70$ , and a non-significant SDA for the non-crossing invalid targets (horizontal shifts:  $M = 84.36$  ms,  $SEM = 17.13$  ms; vertical shifts:  $M = 105.11$  ms,  $SEM = 17.13$  ms),  $t(14) = 0.61, p = .555, d = 0.19$ . Similarly, for the lower right object, we observed a significant horizontal SDA for the crossing invalid targets (horizontal shifts:  $M = 283.92$  ms,  $SEM = 21.59$  ms; vertical shifts:  $M = 394.82$  ms,  $SEM = 21.59$  ms),  $t(14) = 2.57, p = .022, d = 0.64$ , and a non-significant SDA for the non-crossing invalid targets (horizontal shifts:  $M = 112.02$  ms,  $SEM = 20.60$  ms; vertical shifts:  $M = 111.14$  ms,  $SEM = 20.60$  ms),  $t(14) = 0.02, p = .983, d = 0.01$ . This pilot study demonstrated that both a significant SDA for crossing invalid targets and a non-significant SDA for non-crossing invalid targets can be measured

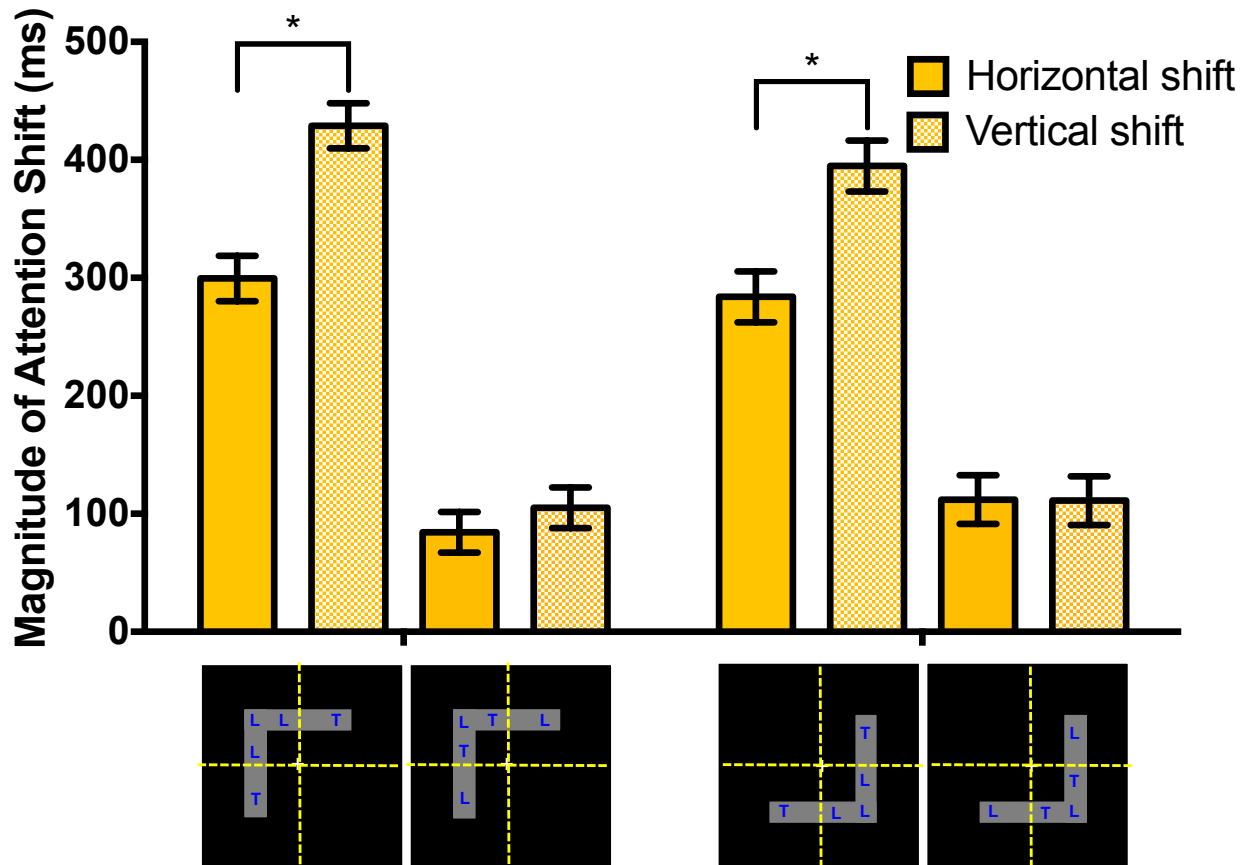

**Figure 32. Mean response latencies across object in fMRI Pilot Study.** “Magnitude of Attention Shift” measured for each Shift Direction and Target Array. Data displayed for upper left and lower right objects. Icons contain two targets (‘T’) to indicate a crossing or non-crossing Target Array. The error bars represent the standard error of the mean for within-subjects design.

simultaneously within the same paradigm. Thus, we were confident that the modifications to the experimental task would be conducive to producing the expected pattern of behavioral results.

**Retinotopic meridian mapping localizer.** Each participant completed one run (312 s) of a retinotopic meridian-mapping task (Greenberg, Verstynen, Chiu, Yantis, Scheider, & Behrmann, 2012) to delineate the borders between dorsal and ventral V1, V2, and V3 in visual cortex. Stimuli consisted of contrast-reversing checkerboard wedges alternating at 8Hz along the horizontal and vertical meridians (See Fig. 33). The task was bookended by 12 s of fixation. The horizontal meridian was stimulated first before alternating with the vertical meridian. Each

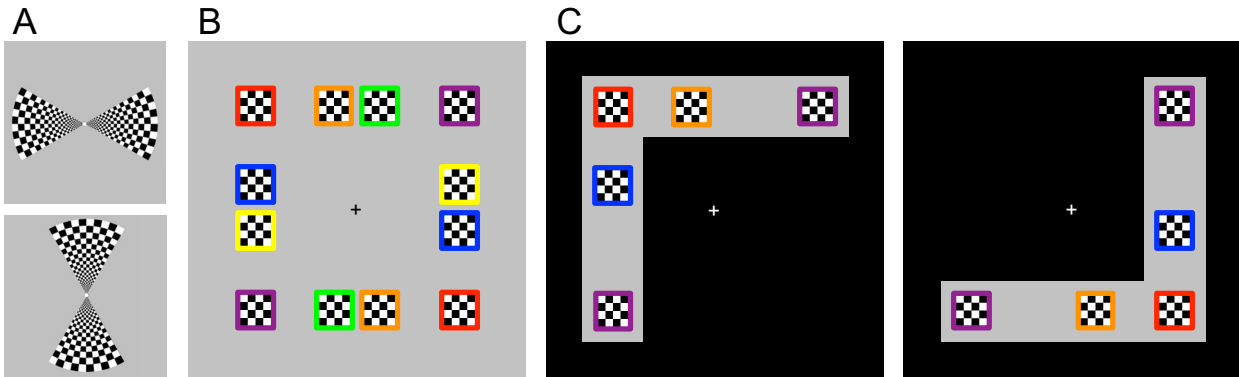

**Figure 33. Localizers in the fMRI Experiment.** (A) Contrast reversing checkerboard wedges used in the retinotopic meridian mapping localizer to delineate the borders between dorsal and ventral V1-V3. (B) Contrast reversing checkerboard squares used in the target location mapping localizer to identify the retinotopic representations of all target locations used in the Experimental Task. A dyad consists of a pair of squares outlined in the same color, and only one dyad was presented at a time. (C) Target locations in the Experimental task corresponding to a dyad from the target location mapping localizer. *Note.* Depictions not drawn to scale. Colored outlines were not part of the target location localizer.

meridian was stimulated 8 times for 18 s each. During this task, participants fixated on a central black fixation square that randomly changed color to white for variable durations. Participants were instructed to hold down a button every time the black fixation square changed to white and release it when it changed back to black.

**Target location mapping localizer.** Each participant completed two runs (462 s each) of a target location-mapping task (Uyar, Shomstein, Greenberg, & Behrmann, 2016) to localize target-based activation for selection of ROIs. Stimuli consisted of contrast-reversing checkerboard squares alternating at 4Hz and were presented in the same locations of the targets in the experimental task. There were 6 dyads (See Fig. 33), each presented 3 times in random order. The task began with an initial fixation of 10 s. Each dyad was stimulated for 10 s, with a 9 s fixation in between successive dyads. During this task, participants were instructed to maintain

central fixation while indicating, via button press, when the centrally presented fixation cross changed color.

**fMRI analysis pipeline.**

***fMRI preprocessing.*** FreeSurfer (Dale, Fischl, & Sereno, 1999; Fischl, Sereno, & Dale, 1999) was used to segment gray matter from white matter in the T1-weighted anatomical image and generate cortical surface representations for each hemisphere. Functional data were analyzed with AFNI (Cox, 1996) and SUMA (Saad, Reynolds, Argall, Japee, & Cox, 2004). Before functional data were analyzed, the first 6 volumes of each run were discarded. Next, functional runs were slice-time corrected, motion-corrected, co-registered to the anatomical volume, and mapped to the inflated cortical surface. Finally, functional data were converted to percent signal change values normalized to the mean of each run and spatially smoothed. All analyses were conducted on these inflated surface-mapped data.

***Retinotopic meridian and target location mapping localizers.*** First, the retinotopic meridian mapping localizer was used to delineate visual cortex borders (dorsal and ventral V1-V3) by contrasting regressors from the horizontal and vertical meridian conditions. The borders between visual areas were then hand-drawn on the cortical surface, following the path of maximal activation anteriorly from the occipital pole. Next, the target location mapping localizer was used to identify ROIs that correspond to the retinotopic locations of the target by contrasting regressors from locations in the upper and lower hemifields of diagonally opposing dyads (e.g., the upper right and lower right locations in the left hemisphere). A 3 mm ROI was grown from the point of maximal activation within dorsal and ventral V1-V3.

***fMRI data extraction.*** Beta-weights were extracted in response to cue-related activity from each ROI when that ROI was the cued location (the object vertex), the non-cued horizontal

location, and the non-cued vertical location. Beta-weights were also extracted in response to target-related activity from each ROI when that ROI contained the target at the valid location, invalid-horizontal location, and the invalid-vertical location. Beta-weights were extracted for each object (upper left and lower right), target array (crossing and not crossing), and region (dorsal and ventral V1-V3) for correct trials and converted into percent signal change. Beta weights capture global signal differences and this fMRI experiment was designed as a simple investigation of whether visual cortex, specifically, would show the effects of the SDA that were consistently observed in behavioral RTs.

## **Results**

**Data quality.** Practice data from one participant could not be analyzed due to missing invalid target RTs (failure to understand instructions for one block). Data from this participant, however, are included in all subsequent analyses because of improved performance while in the scanner. A different participant was excluded from all analyses due to excessively high false alarm (51%) and miss rates (24%). This resulted in a final sample of nine participants ( $M_{\text{age}} = 29.00$  years,  $SD_{\text{age}} = 7.81$  years; 7 women, 2 men).

### **Behavior.**

**Practice session.** Before the MRI session, all participants completed a short practice session in order to become acquainted with the experimental paradigm and to verify that they could accurately complete the task. Each participant experienced one block of each type of Target Array while RTs and accuracy were recorded. The mean false alarm rate was 8% ( $SD = 7\%$ ) and the mean miss rate was 4% ( $SD = 8\%$ ). Mean RT differences were calculated by subtracting mean raw RTs to valid targets from mean RTs to invalid-horizontal targets and invalid-vertical targets, and submitted to a  $2 \times 2 \times 2$  repeated measures ANOVA with Object

(upper left, lower right), Target Array (crossing, non-crossing), and Shift Direction (horizontal, vertical) as within-subjects factors. The analysis revealed a marginally significant main effect of Shift Direction,  $F(1,7) = 5.36$   $p = .054$ ,  $\eta_p^2 = .43$ , such that horizontal shifts of attention ( $M = 96.76$  ms,  $SEM = 21.45$  ms) were faster, albeit not significantly, than vertical shifts of attention ( $M = 196.08$  ms,  $SEM = 21.45$  ms). All other main effects and interactions were not significant, all  $F_s < 1.5$ , all  $p_s > .2$ .

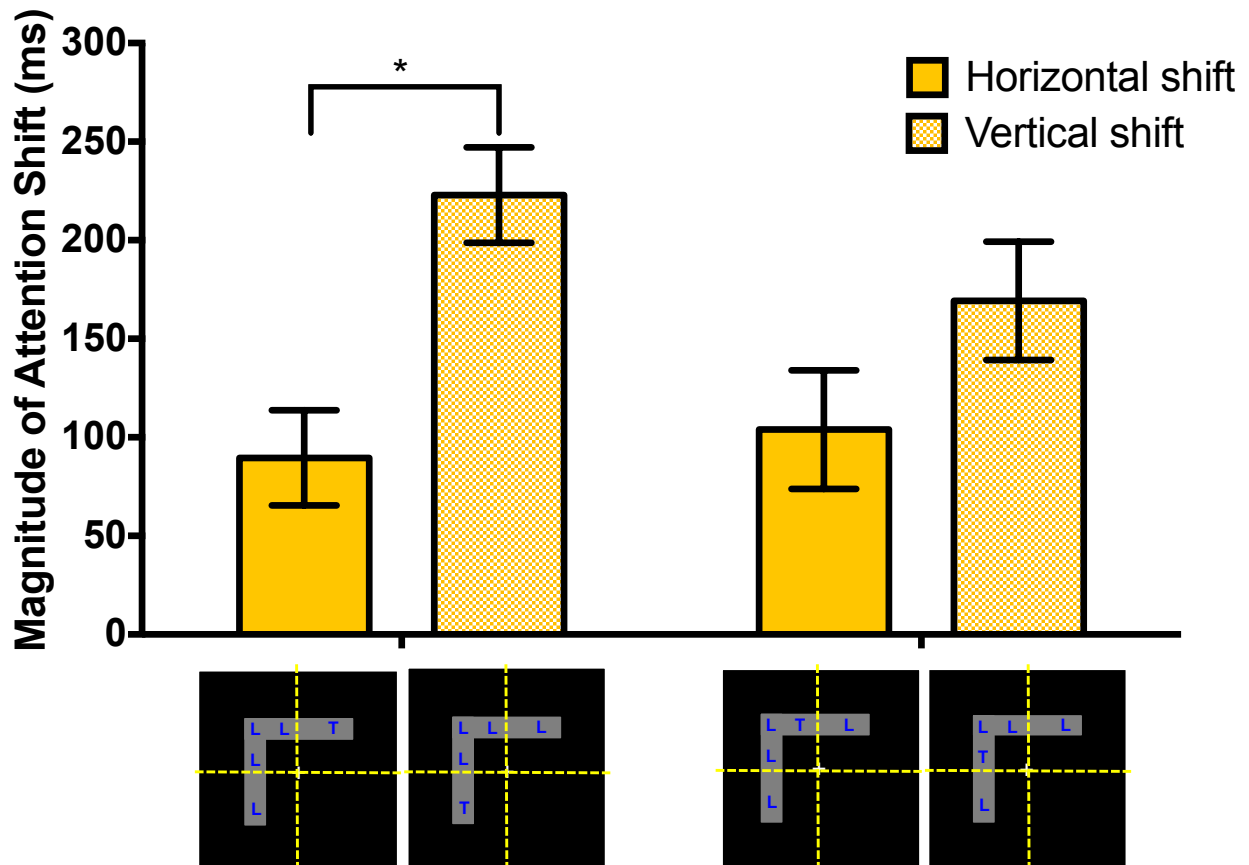

**Figure 34.** Mean response latencies collapsed across object in fMRI Practice Session. “Magnitude of Attention Shift” measured for each Shift Direction and Target Array. The error bars represent the standard error of the mean for within-subjects design.

As seen in Figure 34, when collapsed across Object, planned comparisons revealed that horizontal shifts of attention ( $M = 89.58$  ms,  $SEM = 24.15$  ms) were significantly faster than

vertical shifts of attention ( $M = 222.91$  ms,  $SEM = 24.15$  ms) when invalid target locations crossed the meridians,  $t(7) = 2.76$ ,  $p = .028$ ,  $d = 1.04$ . Additionally, there was no difference between horizontal shifts of attention ( $M = 103.95$  ms,  $SEM = 30.05$ ) and vertical shifts of attention ( $M = 169.26$  ms,  $SEM = 30.05$  ms) when invalid target locations did not cross the meridians,  $t(7) = 1.09$ ,  $p = .313$ ,  $d = 0.36$ . When the results are partitioned by object location (See Fig. 35), planned comparisons revealed a significant horizontal advantage SDA for that invalid target locations that crossed the meridians for the upper left object (horizontal shifts:  $M = 83.67$  ms,  $SEM = 17.07$  ms; vertical shifts:  $M = 239.83$  ms,  $SEM = 17.07$  ms),  $t(7) = 5.57$ ,  $p = .003$ ,  $d = 1.33$ . However, unexpectedly, there was also a significant horizontal advantage SDA

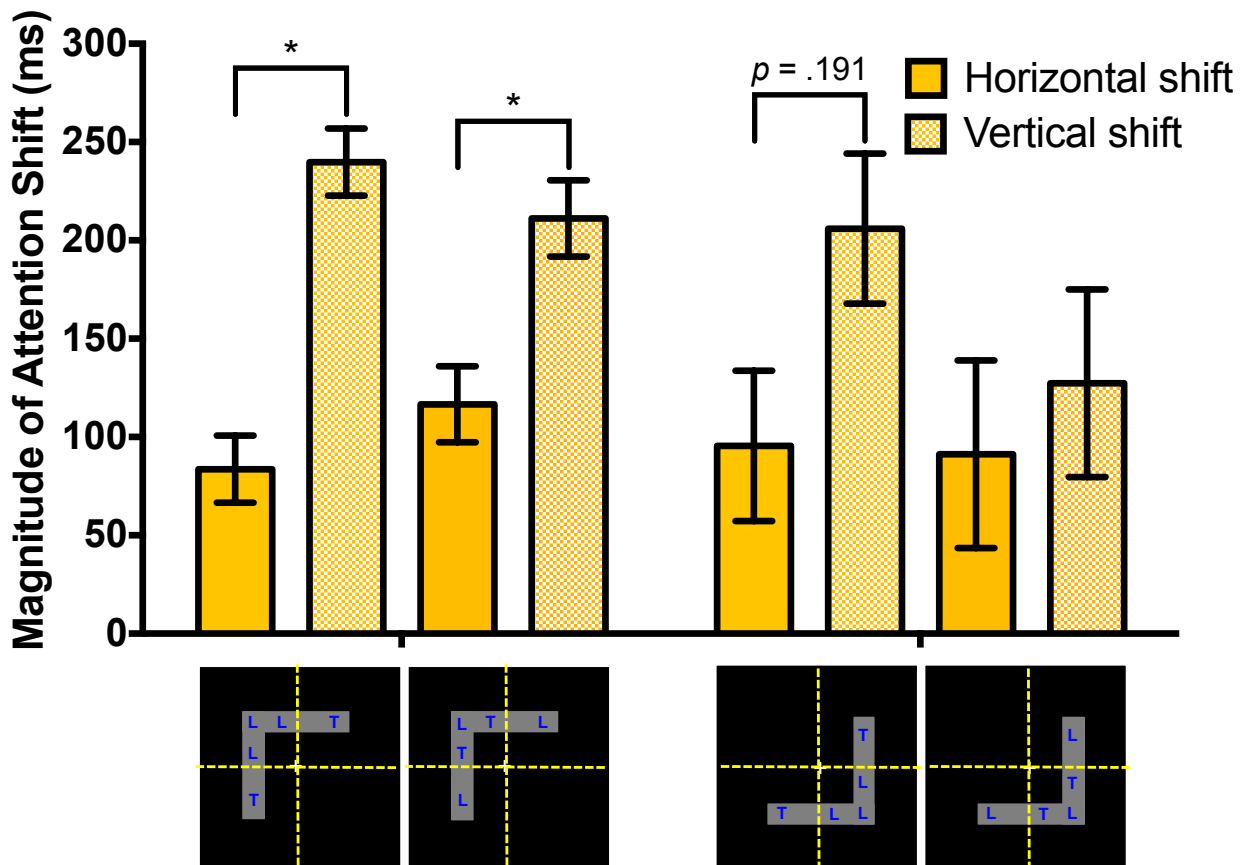

**Figure 35. Mean response latencies across object in fMRI Practice Session.** “Magnitude of Attention Shift” measured for each Shift Direction and Target Array. Icons contain two targets (‘T’) to indicate a crossing or non-crossing Target Array. The error bars represent the standard error of the mean for within-subjects design.

for the invalid target locations that did not cross the meridians (horizontal shifts:  $M = 116.62$  ms,  $SEM = 19.34$  ms; vertical shifts:  $M = 211.16$  ms,  $SEM = 19.34$  ms),  $t(7) = 2.44$ ,  $p = .044$ ,  $d = 0.38$ . The opposite was observed for the lower right object. As expected, we observed a non-significant SDA when the invalid target locations did not cross the meridians (horizontal shifts:  $M = 91.27$  ms,  $SEM = 47.73$  ms; vertical shifts:  $M = 127.35$  ms,  $SEM = 47.73$  ms),  $t(7) = 0.38$ ,  $p = .717$ ,  $d = 0.19$ . But a non-significant SDA was also observed when the invalid target locations crossed the meridians (horizontal shifts:  $M = 95.49$  ms,  $SEM = 38.19$  ms; vertical shifts:  $M = 205.99$  ms,  $SEM = 38.19$  ms),  $t(7) = 1.45$ ,  $p = .191$ ,  $d = 0.41$ .

**Experimental session.** The mean false alarm rate was 6% ( $SD = 5\%$ ) and the mean miss rate was 7% ( $SD = 5\%$ ). Mean RT differences were calculated by subtracting mean raw RTs to valid targets from mean RTs to invalid-horizontal targets and invalid-vertical targets, and submitted to a  $2 \times 2 \times 2$  repeated measures ANOVA, with Object (upper left, lower right), Target Array (crossing, non-crossing), and Shift Direction (horizontal, vertical) as within-subjects factors. The ANOVA revealed a main effect of Shift Direction,  $F(1,8) = 5.31$ ,  $p = .050$ ,  $\eta_p^2 = .40$ , such that horizontal shifts of attention ( $M = 180.85$  ms,  $SEM = 10.50$  ms) were significantly faster than vertical shifts of attention ( $M = 229.54$  ms,  $SEM = 10.50$  ms). There was also a main effect of Target Array,  $F(1,8) = 19.72$ ,  $p = .002$ ,  $\eta_p^2 = .71$ , such that RTs for detecting invalid targets that did not cross the meridians ( $M = 90.91$  ms,  $SEM = 25.70$  ms) were significantly faster than RTs for detecting invalid targets that crossed the meridians ( $M = 319.19$  ms,  $SEM = 25.70$  ms). The main effect of Object was marginally significant,  $F(1,8) = 4.46$ ,  $p = .068$ ,  $\eta_p^2 = .36$ , indicating a trend for faster RTs on the lower right object ( $M = 173.87$  ms,  $SEM = 14.76$  ms) versus the upper left object ( $M = 236.23$  ms,  $SEM = 14.76$  ms). The ANOVA also revealed a

significant Object x Shift Direction interaction,  $F(1,8) = 10.00$ ,  $p = .013$ ,  $\eta_p^2 = .56$ . No other interactions were significant, all  $F_s < 0.9$ , all  $p_s > .37$ .

The interaction between Object and Shift Direction revealed, for the upper left object, significantly faster horizontal shifts of attention ( $M = 162.39$  ms,  $SEM = 16.62$  ms) compared to vertical shifts of attention ( $M = 310.07$  ms,  $SEM = 16.62$  ms),  $t(8) = 4.44$ ,  $p = .002$ ,  $d = 0.92$  (See Fig. 36). However, for the lower right object, there was no difference between horizontal shifts of attention ( $M = 199.31$  ms,  $SEM = 20.92$  ms) and vertical shifts of attention ( $M = 148.44$ ,  $SEM = 20.92$  ms),  $t(8) = 1.22$ ,  $p = .259$ ,  $d = 0.25$ . In fact, vertical shifts of attention were faster than

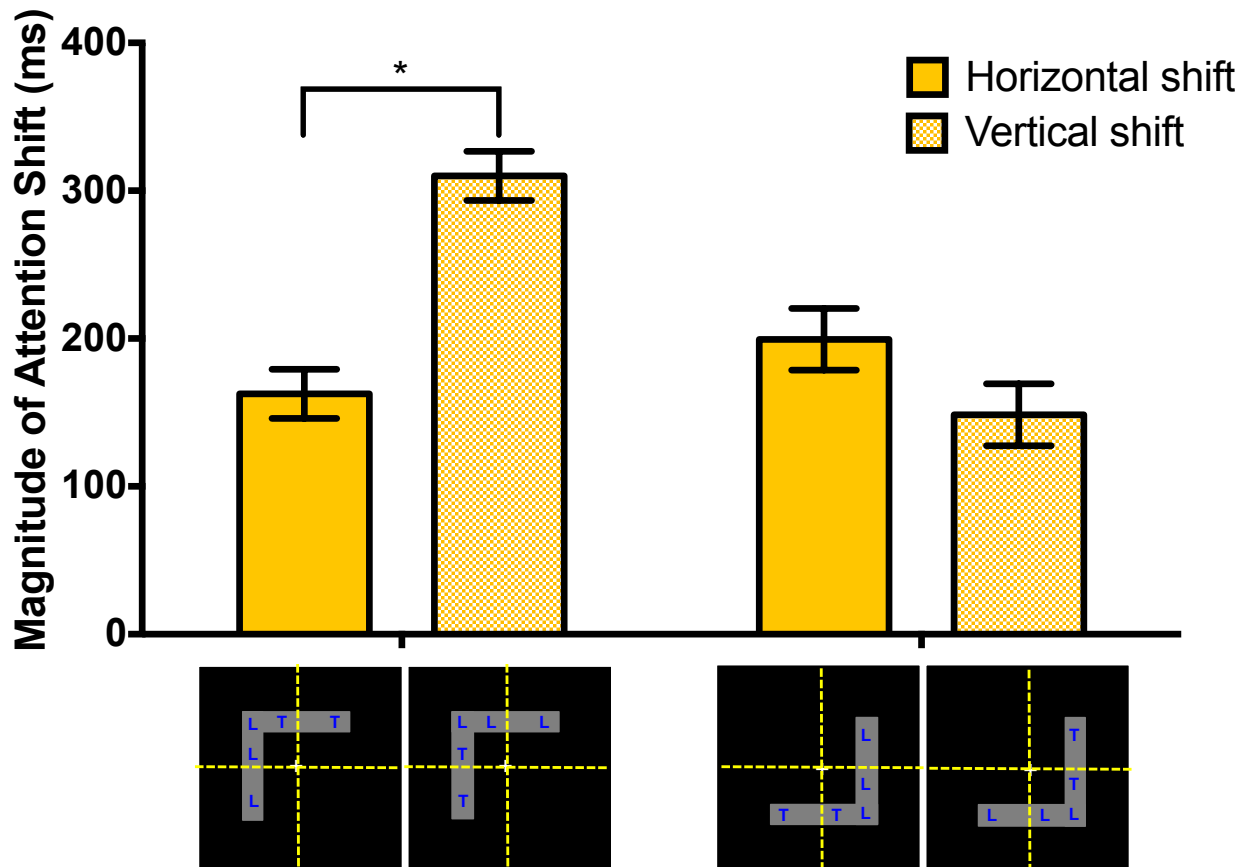

**Figure 36. Mean response latencies for Object x Shift Direction interaction in fMRI Experimental Session.** “Magnitude of Attention Shift” measured for the Object x Shift Direction interaction. Icons contain two targets (‘T’) to indicate that Target Array was not a factor in Shift Direction. The error bars represent the standard error of the mean for within-subjects design.

horizontal shifts of attention in the lower right object, evidence of a reversal in the direction of the SDA. Thus, the interaction between Object and Shift Direction was driven by a significantly larger horizontal advantage SDA for the upper left object (147.66 ms) compared to the non-significant vertical advantage for the lower right object (50.87 ms).

As seen in Figure 37, when collapsed across Object, there was no significant difference between horizontal shifts of attention and vertical shifts of attention when invalid target locations crossed the meridians (horizontal shifts:  $M = 296.58$  ms,  $SEM = 18.17$  ms; vertical shifts:  $M = 341.80$  ms,  $SEM = 18.17$  ms),  $t(8) = 1.24$ ,  $p = .249$ ,  $d = 0.19$ . However, when invalid target locations did not cross the meridians, horizontal shifts of attention were marginally faster than

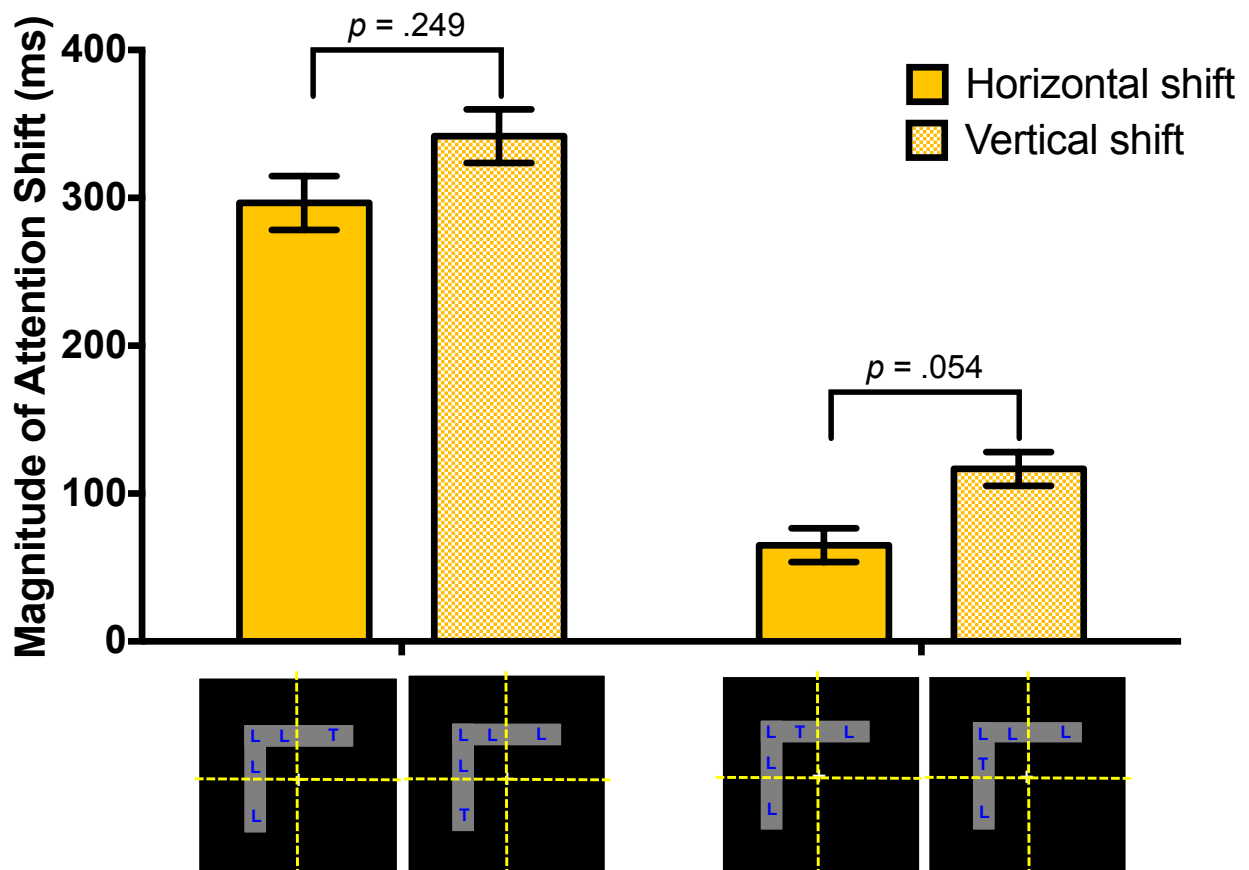

**Figure 37. Mean response latencies collapsed across object in fMRI Experimental Session.** “Magnitude of Attention Shift” measured for each Shift Direction and Target Array. The error bars represent the standard error of the mean for within-subjects design.

vertical shifts of attention (horizontal shifts:  $M = 65.12$  ms,  $SEM = 11.42$  ms; vertical shifts:  $M = 116.71$  ms,  $SEM = 11.42$  ms),  $t(8) = 2.26$ ,  $p = .054$ ,  $d = 0.41$ .

When the results are separated out by object location (See Fig. 38), planned comparisons revealed a significant horizontal advantage SDA for invalid target locations that crossed the meridians (horizontal shifts:  $M = 269.08$  ms,  $SEM = 29.02$  ms; vertical shifts:  $M = 439.73$  ms,  $SEM = 29.02$  ms),  $t(8) = 2.94$ ,  $p = .019$ ,  $d = 0.72$ , and for invalid target locations that did not cross the meridians (horizontal shifts:  $M = 55.71$  ms,  $SEM = 14.93$  ms; vertical shifts:  $M = 180.41$  ms,  $SEM = 14.93$  ms),  $t(8) = 4.18$ ,  $p = .003$ ,  $d = 1.01$ . Moreover, there were no significant SDAs associated with the lower right object. However, the lower right object exhibited evidence

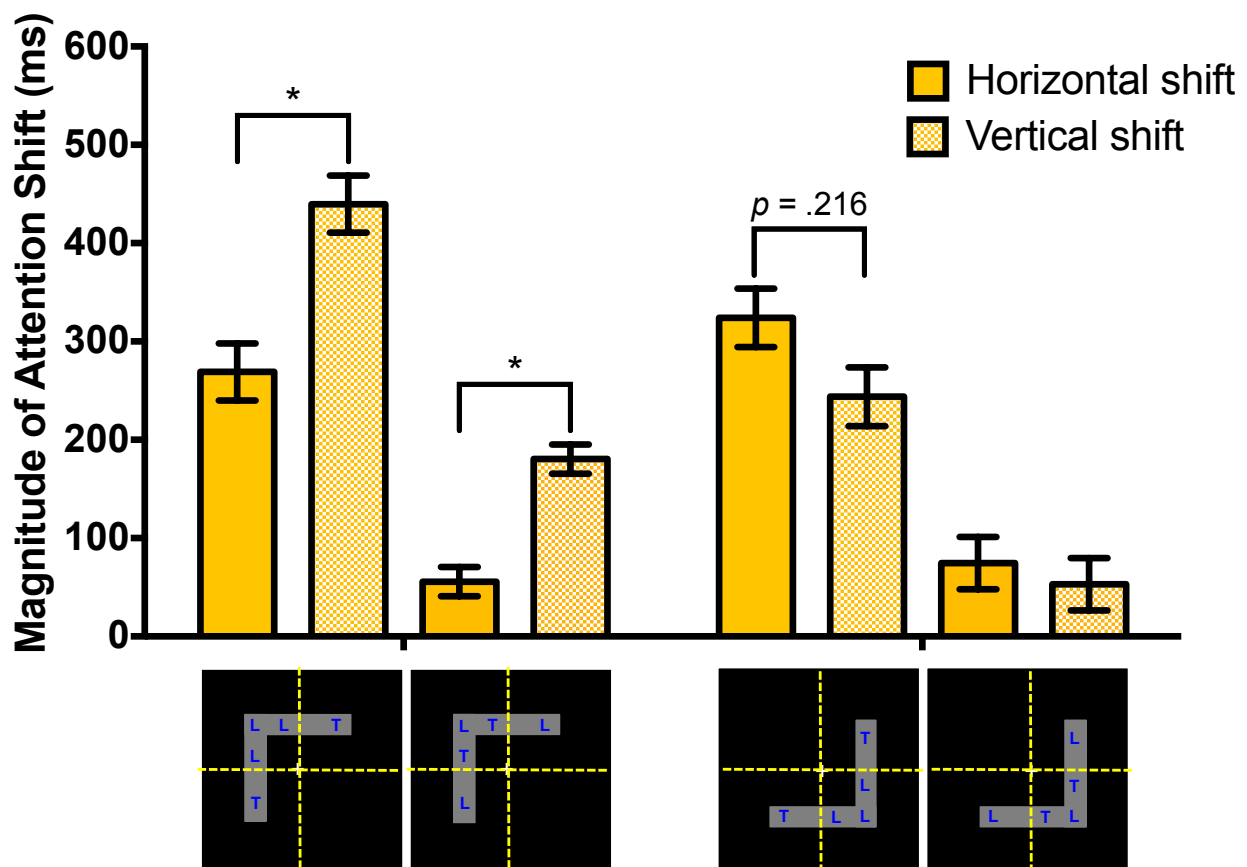

**Figure 38. Mean response latencies across object in fMRI Experimental Session.** “Magnitude of Attention Shift” measured for each Shift Direction and Target Array. Icons contain two targets (“T”) to indicate a crossing or non-crossing Target Array. The error bars represent the standard error of the mean for within-subjects design.

of a vertical shift advantage, where vertical shifts of attention ( $M = 243.87$  ms,  $SEM = 29.86$  ms) were numerically faster than horizontal shifts of attention ( $M = 324.08$  ms,  $SEM = 29.86$  ms) for invalid target locations that crossed the meridians,  $t(8) = 1.34$ ,  $p = .216$ ,  $d = 0.30$ . There was also no difference for invalid target locations that did not cross the meridians (horizontal shifts:  $M = 74.54$  ms,  $SEM = 26.59$  ms; vertical shifts:  $M = 53.00$  ms,  $SEM = 26.59$  ms),  $t(8) = 0.41$ ,  $p = .696$ ,  $d = 0.13$ .

### **Cue-related activity.**

**Omnibus ANOVA.** Beta-weights (percent signal change) were entered into an omnibus repeated measures ANOVA with Region (V1, V2, V3), Object (upper left, lower right), Target Array (crossing, non-crossing), and Cueing (cued vertex, non-cued horizontal location, non-cued vertical location) as within-subjects factors. There was a main effect of Region,  $F(2,16) = 4.39$ ,  $p = .030$ ,  $\eta_p^2 = .35$ , such that cue-related activity in V3 ( $M = -0.450$ ,  $SEM = 0.098$ ) was significantly decreased compared to activity in V1 ( $M = 0.032$ ,  $SEM = 0.106$ ),  $t(8) = 2.55$ ,  $p = .034$ ,  $d = 1.33$ . Cue-related activity in V2 ( $M = -0.158$ ,  $SEM = 0.078$ ) did not differ significantly from activity in V1,  $t(8) = 1.21$ ,  $p = .262$ ,  $d = 0.44$ , but was marginally greater than activity in V3,  $t(8) = 2.06$ ,  $p = .073$ ,  $d = 0.67$ . There was also a marginal main effect of Target Array,  $F(1,8) = 4.01$ ,  $p = .080$ ,  $\eta_p^2 = .35$ , driven by a significant reduction in cue-related activity for invalid target locations that crossed the meridians ( $M = -0.283$ ,  $SEM = 0.047$ ) versus invalid target locations that did not cross the meridians ( $M = -0.096$ ,  $SEM = 0.047$ ). Additionally, there were marginal interactions between Region and Target Array,  $F(2,16) = 3.15$ ,  $p = .070$ ,  $\eta_p^2 = .28$ , and Size and Cueing,  $F(2,16) = 3.58$ ,  $p = .052$ ,  $\eta_p^2 = .31$ . There were no other main effects or interactions, all  $F$ s  $< 2.7$ , all  $p$ s  $> .1$ . The marginal 2-way interactions are each detailed below.

*Region and target array.* To understand this interaction, two one-way ANOVAs with Region as a single factor were performed separately for each type of target array (See Fig. 39). There was a simple effect of region on cue-related activity for invalid target locations that did not cross the meridians,  $F(2,16) = 7.43, p = .005, \eta_p^2 = .48$ . Paired comparisons indicated a significant decrease in activity in V3 ( $M = -0.431, SEM = 0.101$ ) compared to V1 ( $M = 0.151, SEM = 0.094$ ) and V2 ( $M = -0.014, SEM = 0.072$ ), all  $t_s > 2.8$ , all  $p_s < .02$ . There was no difference between V1 and V2,  $t(8) = 1.24, p = .250, d = 0.39$ . Cue-related activity for invalid target locations that crossed the meridians did not vary significantly along V1-V3,  $F(2,16) = 2.12, p = .153, \eta_p^2 = .21$ .

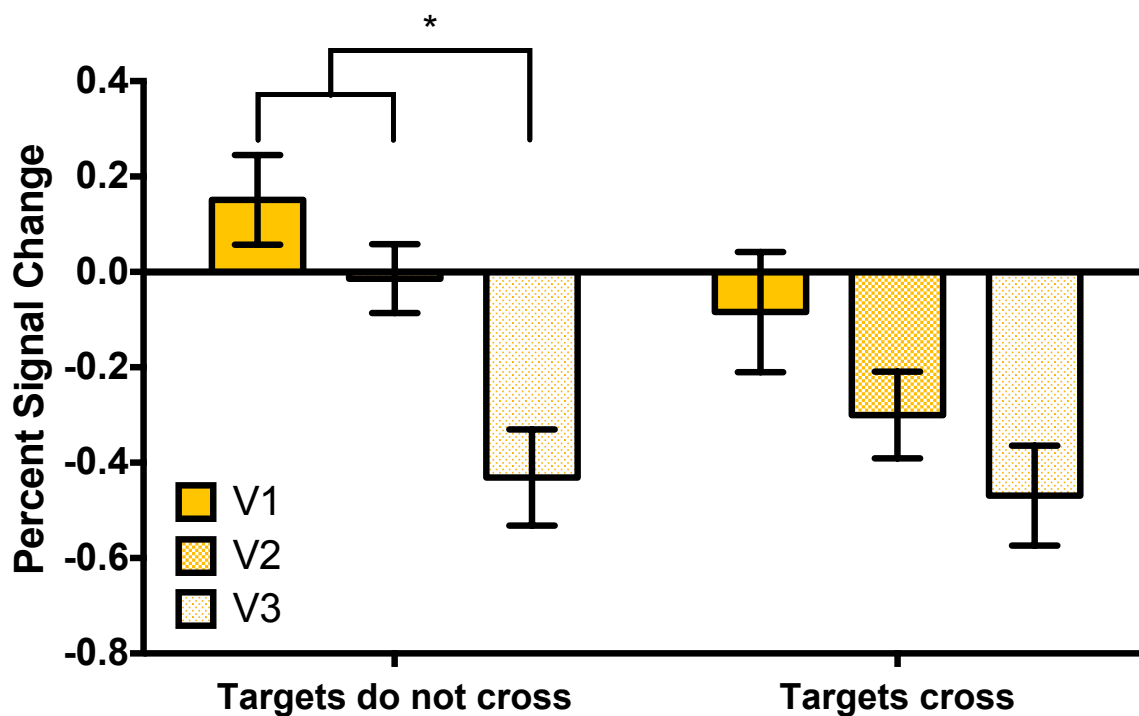

**Figure 39.** Cue-related activity for the Region and Target Array interaction. Percent signal change in cue-related activity for the Region and Target Array interaction. The error bars represent the standard error of the mean for within-subjects design.

*Target array and cueing.* Data from this interaction are visualized in Figure 40. Cue-related activity was examined with two one-way ANOVAs. There were no differences in cue-related activity for the non-crossing target array,  $F(2,16) = 0.10, p = .902, \eta_p^2 = .01$ . However, cue-related activity for the crossing target array varied marginally,  $F(2,16) = 2.99, p = .079, \eta_p^2 = .27$ . Independent samples *t*-tests revealed no difference between cue-related activity at the cued vertex ( $M = -0.127, SEM = 0.068$ ) and the non-cued vertical location ( $M = 0.024, SEM = 0.222$ ),  $t(8) = 0.68, p = .518, d = 0.27$ . However, there was a marginal difference between cue-related activity at the cued vertex and activity in the non-cued horizontal location ( $M = -0.753, SEM = 0.244$ ),  $t(8) = 2.22, p = .057, d = 0.89$ . The result of a one-sample *t*-test also confirmed that the cue-related activity at the non-cued horizontal location was significantly different than zero,  $t(8) = 2.47, p = .038, d = 0.82$ . Together, these results indicate a significant difference in target-

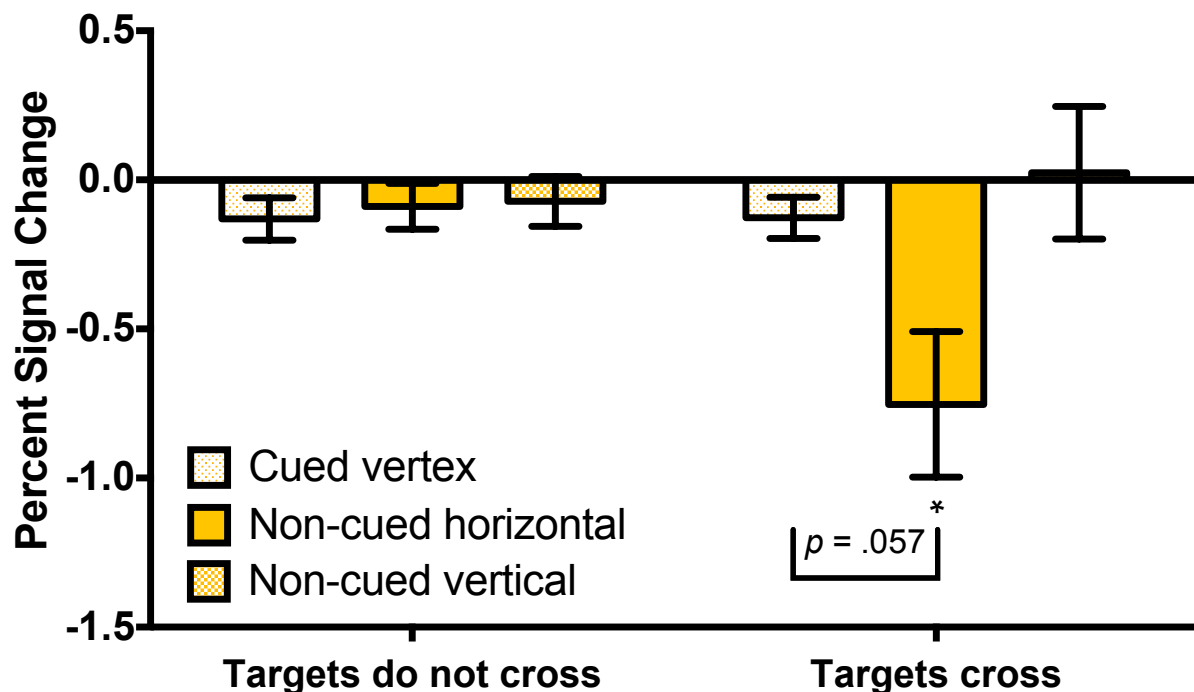

**Figure 40.** Cue-related activity for the Cueing and Target Array interaction. Percent signal change in cue-related activity for Cueing and Target array interaction. The error bars represent the standard error of the mean for within-subjects design.

related activity at the non-cued horizontal location relative to the cued vertex and the non-cued vertical location for the crossing target array.

To further understand the effect of Cueing on Target Array, two values were computed separately for both types of target arrays that index prioritization of the cue at the cued location (Vertex prioritization: the difference between the cued vertex location minus the average of the non-cued locations) and the non-cued locations (SDA prioritization: the difference between the non-cued vertical location minus the non-cued invalid horizontal location). One-sample *t*-tests were then performed on each value to determine whether or not the effect was significantly different than zero (See Fig. 41). There were no significant effects of Vertex prioritization or SDA prioritization for invalid target locations that did not cross the meridians, all *t*s < 0.5, all *p*s > .6, indicating no differences in cue-related activity between cued and non-cued locations.

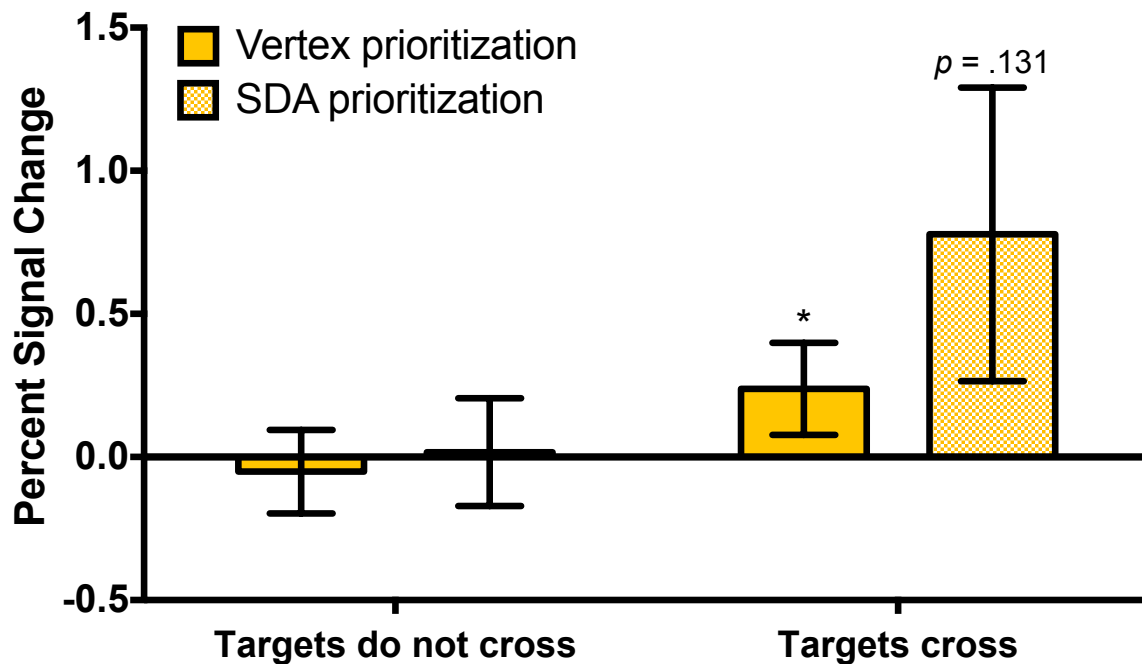
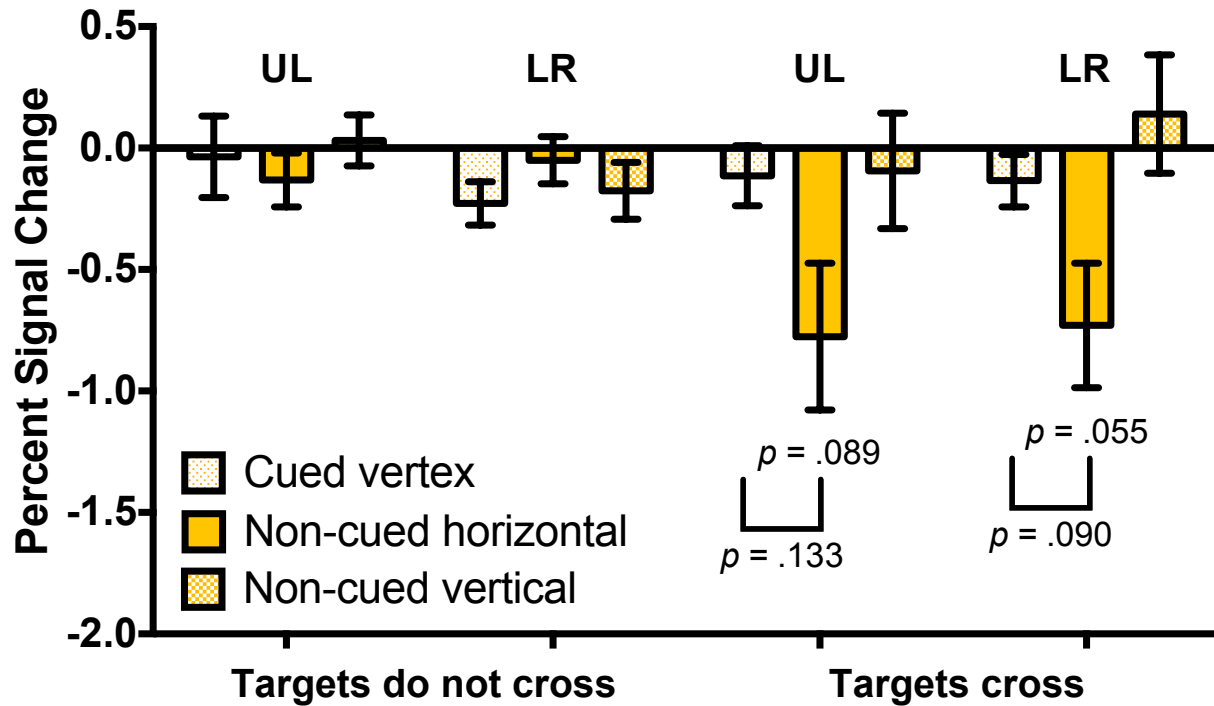

**Figure 41.** Prioritization of the cued vertex and non-cued vertical and horizontal locations for both non-crossing and crossing target arrays. Percent signal change in cue-related activity for cue prioritization as a function of target array. The error bars represent the standard error of the mean for within-subjects design.

However, there was an effect of Vertex prioritization when invalid target locations crossed the meridians,  $t(8) = 2.31$ ,  $p = .050$ ,  $d = 0.77$ , indicating significant prioritization of the cue at the vertex compared to the non-cued locations. Although there was no effect of SDA prioritization for invalid target locations that crossed the meridians,  $t(8) = 1.68$ ,  $p = .131$ ,  $d = 0.56$ , the magnitude of the effect indicates a difference in the prioritization of the cue at the non-cued horizontal location and the non-cued vertical location.

***Exploratory analyses.*** In order to fully understand what was occurring with the cue-related activity, several exploratory analyses were also conducted that were in line with our hypotheses and overall goal of this experiment.

*Object, target array, and cueing.* The 3-way interaction between Object, Target Array, and Cueing was not significant in the omnibus ANOVA,  $F(2,16) = 0.61$ ,  $p = .555$ ,  $\eta_p^2 = .07$ ; however, we explored this interaction to examine if cue-related activity varied across retinotopic locations. These data are visualized in Figure 42. A one-way ANOVA was conducted separately for each Object and Target Array (e.g., invalid target locations in the upper left object that did not cross the meridians). For the non-crossing target array, cue-related activity did not differ significantly in the upper left object,  $F(2,16) = 0.26$ ,  $p = .775$ ,  $\eta_p^2 = .03$ , or in the lower right object,  $F(2,16) = 0.55$ ,  $p = .589$ ,  $\eta_p^2 = .06$ . The results of the one-way ANOVAs for the crossing target array were also not significant for the upper left object,  $F(2,16) = 1.84$ ,  $p = .190$ ,  $\eta_p^2 = .19$ , or the lower right object,  $F(2,16) = 2.90$ ,  $p = .084$ ,  $\eta_p^2 = .27$ . Pairwise comparisons revealed no significant cue-related differences in the upper left object, all  $ts < 1.7$ , all  $ps > .1$ , or in the lower right object, all  $ts < 1$ , all  $ps > .09$ , though there were trends for significantly decreased cue-related activity in the non-cued horizontal location compared to the cued vertex location for the



**Figure 42. Retinotopic cue-related activity for Object, Target Array, and Cueing.** Percent signal change in cue-related activity for Cueing as a function of Object and Target Array. The error bars represent the standard error of the mean for within-subjects design.

upper left object,  $p = .133$ , and the lower right object,  $p = .090$ . Results of one-sample  $t$ -tests revealed that cue-related activity in the non-cued horizontal location of the lower right object was marginally different than zero,  $t(8) = 2.25$ ,  $p = .055$ ,  $d = 0.75$  ( $p = .089$  for the upper left object).

Vertex prioritization and SDA prioritization values were also computed, separately for each target array in the upper left object and lower right object (See Fig. 43). The results of one-sample  $t$ -tests revealed no significant or marginally significant cue prioritization effects, all  $t$ s  $< 1.8$ , all  $p$ s  $> .11$ . This was expected for the non-crossing invalid target locations (See Fig. 41), but unexpected for the crossing invalid target locations. In general, though, both Vertex and SDA prioritization effects appear to trend in the expected directions for the crossing targets, with

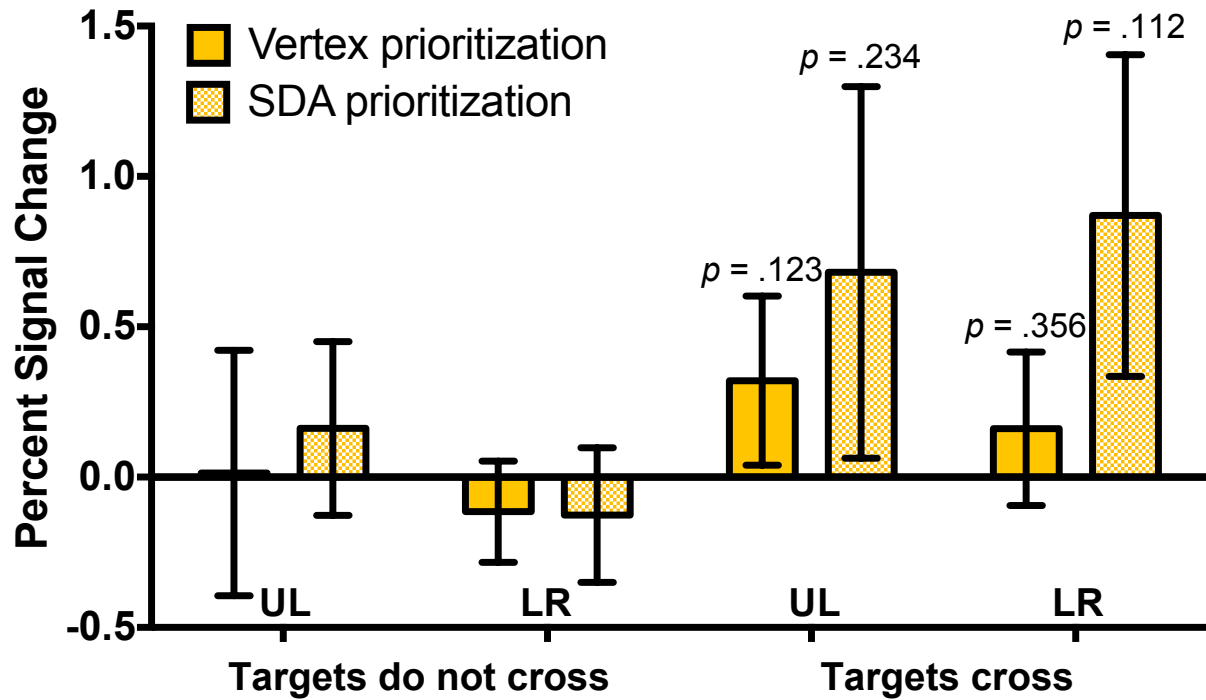

**Figure 43. Retinotopic prioritization of the cued vertex and non-cued vertical and horizontal locations for both Objects and Target Arrays.** Percent signal change in cue-related activity for cue prioritization as a function of Object and Target Array. The error bars represent the standard error of the mean for within-subjects design.

positive vertex prioritization effects (indicating larger cue-related activity at the cued vertex relative to the non-cued locations) and positive SDA prioritization effects (indicating a difference in cue prioritization at the non-cued horizontal location and the non-cued vertical location) for both upper left and lower right objects.

*Cue-related activity in the same retinotopic location.* The non-cued locations of the target arrays that cross the meridians occupy the same retinotopic location in visual cortex (See Fig. 33). For example, the non-cued horizontal location on the upper left object is in the same retinotopic location (upper right quadrant) as the non-cued vertical location on the lower right object. Additionally, the non-cued vertical location on the upper left object (lower left quadrant) is in the same retinotopic location as the non-cued horizontal location on the lower right object.

This design feature allows us to probe these two retinotopic locations to see if cue-related activity differs as a result of whether it is prioritized as a non-cued horizontal location or a non-cued vertical location, depending on the object.

When collapsed across region, the result of an independent-samples *t*-test revealed no significant difference in cue-related activity at the lower left location between the non-cued horizontal location on the lower right object ( $M = -0.594$ ,  $SEM = 0.223$ ) and the non-cued vertical location on the upper left object ( $M = 0.018$ ,  $SEM = 0.223$ ),  $t(8) = 1.38$ ,  $p = .206$ ,  $d = 0.75$  (See Fig. 44). Additionally, there was no difference in cue-related activity at the upper right location between the non-cued horizontal location on the upper left object ( $M = -0.661$ ,  $SEM = 0.310$ ) and the non-cued vertical location on the lower right object ( $M = 0.276$ ,  $SEM = 0.310$ ),

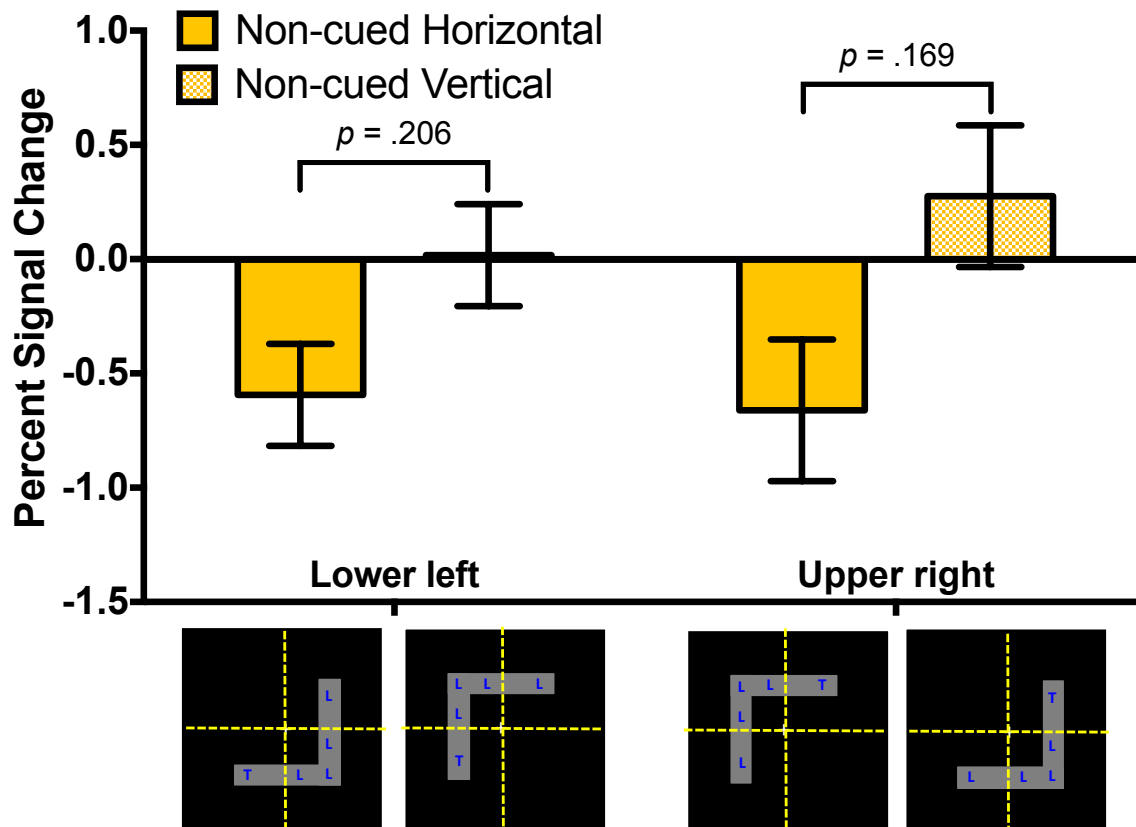

**Figure 44. Cue-related activity in the same retinotopic location.** Percent signal change in cue-related activity at lower left and upper right retinotopic locations that are both types of non-cued locations. The error bars represent the standard error of the mean for within-subjects design.

$t(8) = 1.51, p = .169, d = 0.92$ . In general, though, the data show a decrease in cue-related activity at the non-cued horizontal locations and an increase in cue-related activity at the non-cued vertical locations for both retinotopic locations in the lower left and upper right.

When these data are partitioned by region (See Fig. 45), two marginal differences in cue-related activity are observed in V3 for the lower left location (non-cued horizontal location on the lower right object:  $M = -0.743, SEM = 0.274$ ; non-cued vertical location on the upper left object:  $M = 0.281, SEM = 0.236$ ),  $t(8) = 2.01, p = .079, d = 0.97$ , and in V1 for the upper right location (non-cued horizontal location on the upper left object:  $M = -1.03, SEM = 0.331$ ; non-cued vertical location on the lower right object:  $M = 0.791, SEM = 0.362$ ),  $t(8) = 2.14, p = .065$ ,

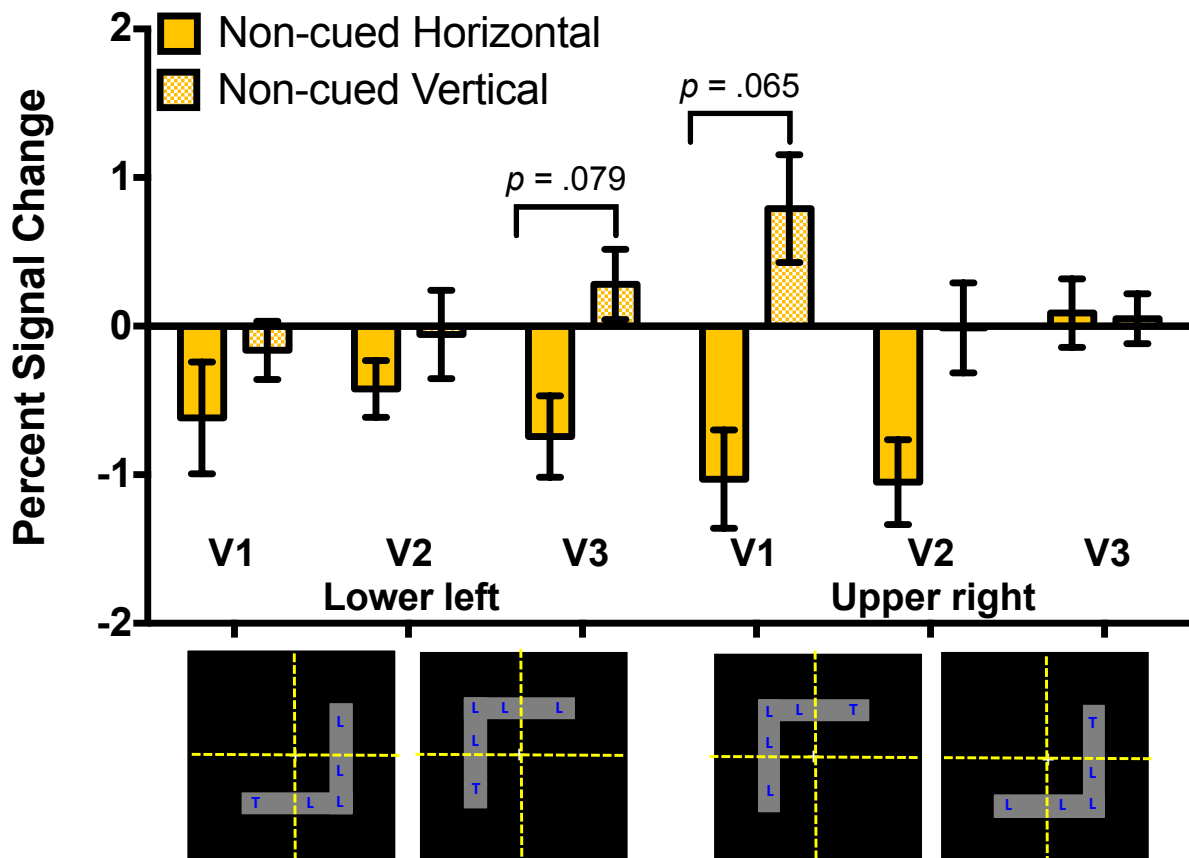

**Figure 45. Cue-related activity in the same retinotopic locations in V1-V3.** Percent signal change in cue-related activity at lower left and upper right retinotopic locations that are both types of non-cued locations. The error bars represent the standard error of the mean for within-subjects design.

$d = 1.21$ . Both of these marginal effects are characterized by a decrease in cue-related activity in the non-cued horizontal location and an increase in activity in the non-cued vertical location. Indeed, there is a general activation pattern associated with a decrease in cue-related activity in non-cued horizontal locations and an increase in activity in the non-cued vertical locations for both objects at these retinotopic locations throughout V1-V3.

### **Target-related activity.**

**Omnibus ANOVA.** Beta-weights were entered into an omnibus repeated measures ANOVA with Region (V1, V2, V3), Object (upper left, lower right), Target Array (crossing, non-crossing), and Shift Direction (hold valid, shift horizontal, shift vertical) as within-subjects factors. There was a significant main effect of Shift Direction,  $F(2,16) = 3.97, p = .040, \eta_p^2 = .33$ , such that target-related activity when shifting attention to an invalid-horizontal location ( $M = 0.246, SEM = 0.055$ ) was significantly increased compared to activity from holding attention at the valid location ( $M = 0.001, SEM = 0.033$ ),  $t(8) = 3.91, p = .004, d = 1.21$ . Target-related activity when shifting attention to an invalid-vertical location ( $M = 0.201, SEM = 0.066$ ) was marginally larger compared to activity from holding attention at the valid location,  $t(8) = 2.24, p = .055, d = 0.69$ . Target-related activity did not significantly differ between shifting attention to invalid-horizontal or invalid-vertical locations,  $t(8) = 0.37, p = .718, d = 0.16$ . There was also a marginally significant main effect of Region,  $F(2,16) = 3.42, p = .058, \eta_p^2 = .30$ , such that target-related activity in V3 ( $M = 0.391, SEM = 0.097$ ) was significantly larger than the activity in V2 ( $M = 0.046, SEM = 0.075$ ),  $t(8) = 3.48, p = .038, d = 0.91$ , and marginally larger than the activity in V1 ( $M = 0.010, SEM = 0.104$ ),  $t(8) = 2.04, p = .075, d = 1.17$ . Target-related activity did not significantly differ between V1 and V2,  $t(8) = 0.24, p = .818, d = .09$ . The omnibus ANOVA also revealed a significant 3-way interaction between Region, Object, and Shift

Direction,  $F(4,32) = 2.99, p = .033, \eta_p^2 = .27$ . There were no other main effects or interactions, all  $F_s < 2$ , all  $p_s > .16$ .

The interaction between Region, Object, and Shift Direction was examined with multiple one-way ANOVAs (See Fig. 46). For the upper left object, target-related activity was significantly different in V1,  $F(2,16) = 5.07, p = .020, \eta_p^2 = .39$ . Target-related activity at the valid location ( $M = -0.562, SEM = 0.139$ ) was significantly lower than the activity at the invalid-horizontal location ( $M = 0.320, SEM = 0.176$ ),  $t(8) = 3.26, p = .012, d = 1.18$ , and marginally lower than the activity at the invalid-vertical location ( $M = -0.023, SEM = 0.166$ ),  $t(8) = 2.14, p = .064, d = 0.84$ . However, target-related activity did not differ between the invalid-horizontal and invalid-vertical locations,  $t(8) = 1.10, p = .303, d = 0.39$ . In V2, the one-way ANOVA was not significant,  $F(2,16) = 1.29, p = .303, \eta_p^2 = .14$ , but activity at the valid location ( $M = -0.269, SEM = 0.119$ ) was significantly lower than the activity at the invalid-horizontal location ( $M = 0.149, SEM = 0.131$ ),  $t(8) = 2.69, p = .027, d = 0.76$ . In V3, the only significant results were that target-related activity at the invalid-vertical location ( $M = 0.413, SEM = 0.122$ ) was significantly

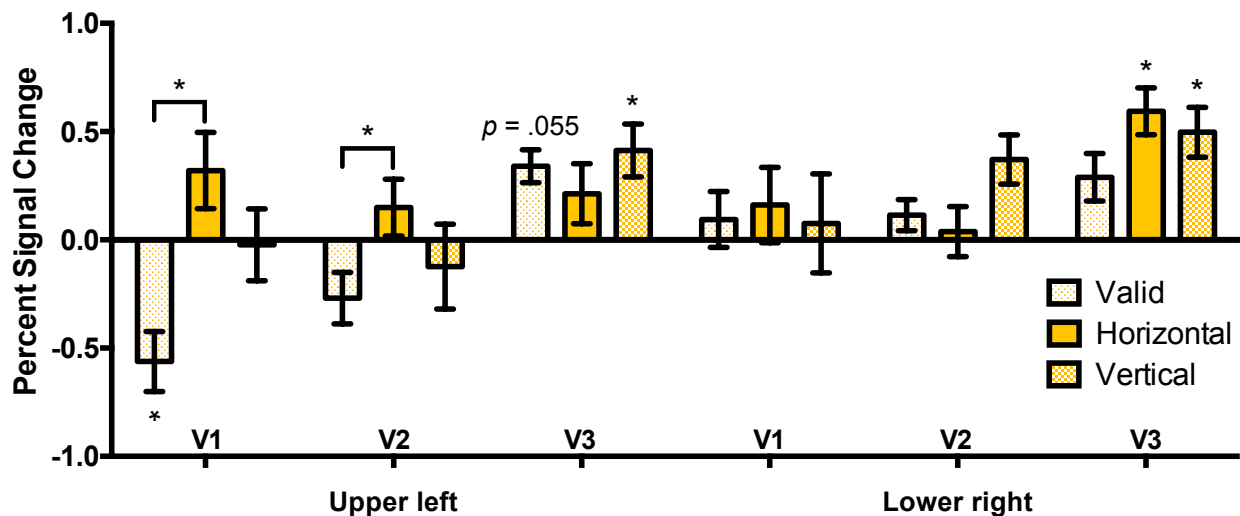

**Figure 46. Target-related activity for Region, Object, and Shift Direction interaction.** Percent signal change in target-related activity for Region, Object, and Shift Direction interaction. The error bars represent the standard error of the mean for within-subjects design.

greater than 0,  $t(8) = 4.19$ ,  $p = .003$ ,  $d = 1.40$ , and marginally greater than 0 at the valid location ( $M = 0.343$ ,  $SEM = 0.076$ ),  $t(8) = 2.25$ ,  $p = .055$ ,  $d = 0.75$ . For the lower right object, all three one-way ANOVAs did not reach significance. The only significant result for the lower right object was in V3, where target-related activity at the invalid-horizontal location ( $M = 0.594$ ,  $SEM = 0.108$ ) and invalid-vertical location ( $M = 0.497$ ,  $SEM = 0.115$ ) were significantly greater than 0,  $t_s > 2.7$ ,  $p_s < .03$ .

The three-way interaction was also examined by calculating values that indexed attentional orienting to the invalid-horizontal location (Horizontal shift: the difference between the invalid-horizontal location minus the valid location) and to the vertical location (Vertical shift: the difference between the invalid-vertical location minus the valid location). These calculations are similar to the calculations used to compute mean RT differences in behavioral data. Independent samples  $t$ -tests revealed no significant differences in target-related activity between horizontal shifts and vertical shifts for either object across V1-V3, all  $t_s < 1.5$ , all  $p_s > .16$  (See Fig. 47). But, for the upper left object, one-sample  $t$ -tests revealed significantly increased target-related activity for horizontal shifts in V1 ( $M = 0.883$ ,  $SEM = 0.156$ ) and V2 ( $M = 0.419$ ,  $SEM = 0.156$ ),  $t_s > 2.7$ ,  $p_s < .03$ . Vertical shifts in the upper left object were marginally greater than 0 in V1,  $t(8) = 2.14$ ,  $p = .064$ ,  $d = 0.71$ .

***Exploratory analyses.*** In order to fully understand what was occurring with the target-related activity, several exploratory analyses were also conducted that were in line with our hypotheses and overall goal of this experiment.

*Target array and shift direction.* The interaction between Target Array and Shift Direction was not significant in the omnibus ANOVA,  $F(2,16) = 0.16$ ,  $p = .853$ ,  $\eta_p^2 = .02$ ; however, we explored this interaction to see if any effects were present in target-related activity.

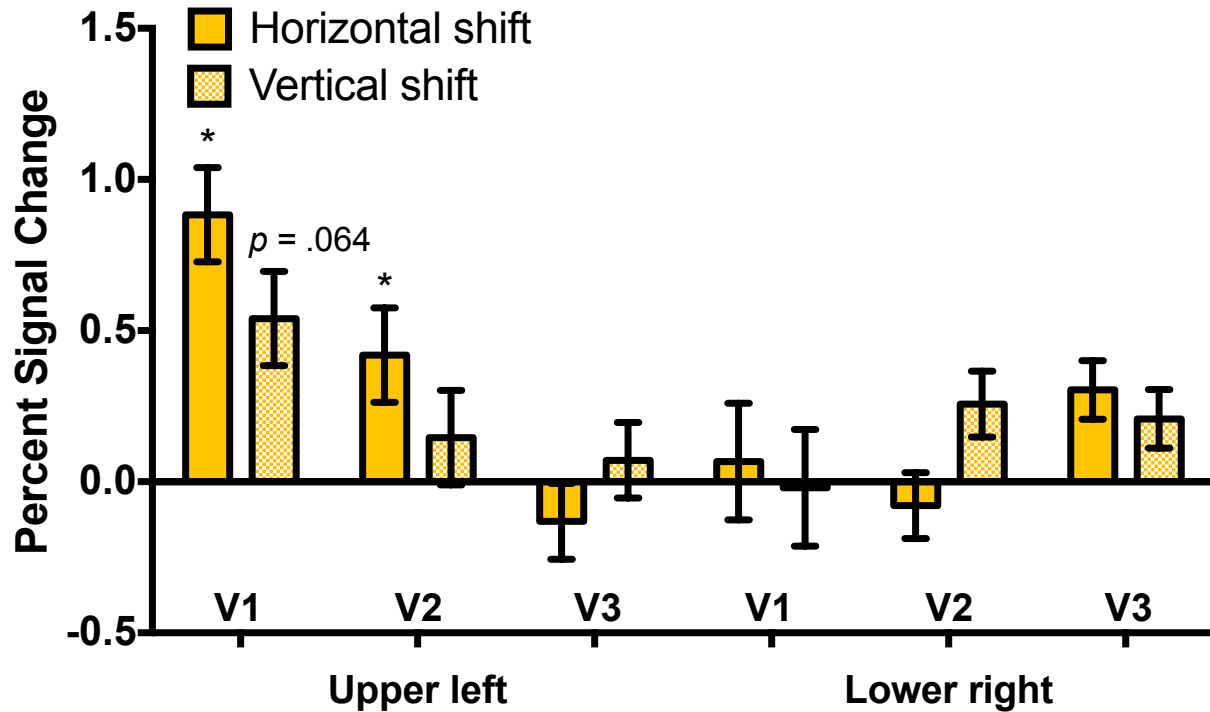

**Figure 47. Attentional orienting at the invalid-horizontal and invalid-vertical target locations as a function of Object and Target Array.** Percent signal change in target-related activity for attentional orienting as a function of Object and Target Array. The error bars represent the standard error of the mean for within-subjects design.

These data are visualized in Figure 48. A one-way ANOVA revealed no significant differences across Shift Direction when invalid target locations did not cross the meridians,  $F(2,16) = 0.98, p = .396, \eta_p^2 = .11$ . Moreover, a one-way ANOVA revealed no significant differences across Shift Direction when invalid target locations crossed the meridians,  $F(2,16) = 1.33, p = .292, \eta_p^2 = .14$ . But, the results of an independent samples *t*-test revealed significantly more target-related activity in the invalid-horizontal location ( $M = 0.278, SEM = 0.121$ ) compared to the valid location ( $M = -0.038, SEM = 0.056$ ),  $t(8) = 2.53, p = .036, d = 0.87$ . Target-related activity at the invalid-vertical location ( $M = 0.156, SEM = 0.142$ ) was not different than activity at the valid location,  $t(8) = 1.09, p = .308, d = 0.38$ .

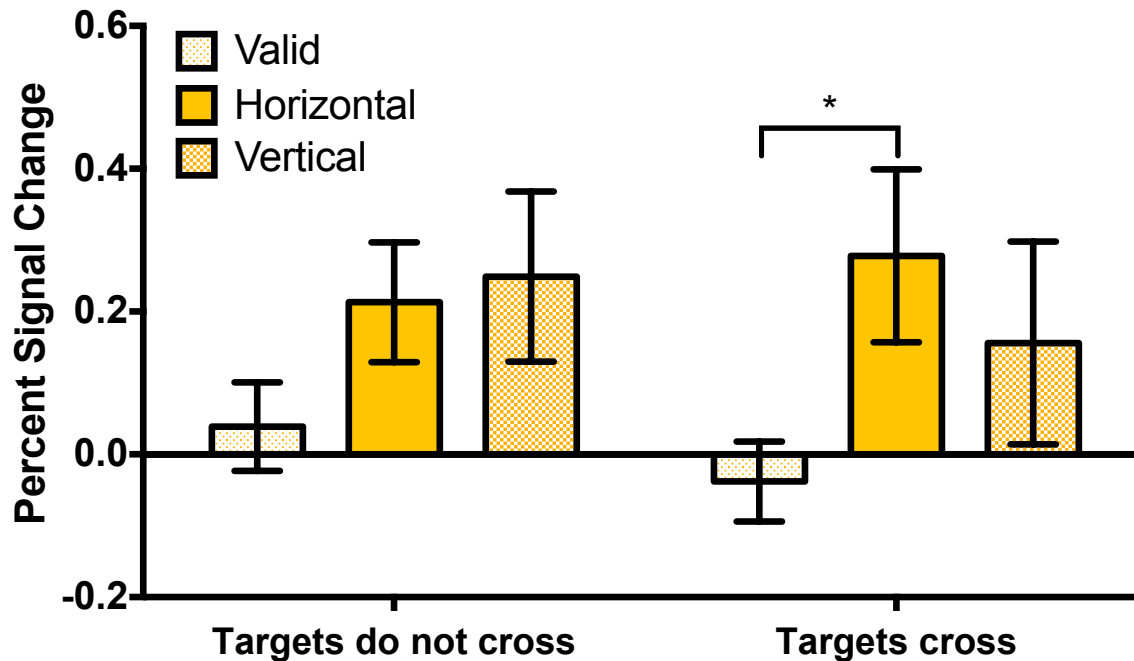

**Figure 48. Target-related activity for Shift Direction and Target Array.** Percent signal change in target-related activity as a function of target location and crossings. The error bars represent the standard error of the mean for within-subjects design.

This interaction can also be understood in terms of attentional orienting to the horizontal and vertical locations from the valid location. Difference scores were computed and submitted to one-sample *t*-tests to see whether an effect was significantly different than zero (See Fig. 49). No significant effects were observed for invalid target locations that did not cross the meridians (horizontal shift:  $M = 0.171$ ,  $SEM = 0.098$ ,  $t(8) = 1.99$ ,  $p = .082$ ,  $d = 0.66$ ; vertical shift:  $M = 0.206$ ,  $SEM = 0.98$ ,  $t(8) = 1.22$ ,  $p = .258$ ,  $d = 0.41$ ). There was a significant effect for horizontal shifts of attention that crossed the meridians ( $M = 0.315$ ,  $SEM = 0.129$ ),  $t(8) = 2.53$ ,  $p = .036$ ,  $d = 0.84$ , but not for vertical shifts of attention that crossed the meridians ( $M = 0.193$ ,  $SEM = 0.129$ ),  $t(8) = 1.09$ ,  $p = .308$ ,  $d = 0.36$ .

*Object, target array, and shift direction.* The 3-way interaction between Object, Target Array, and Shift Direction was not significant in the omnibus ANOVA,  $F(2,16) = 2.02$ ,  $p = .165$ ,

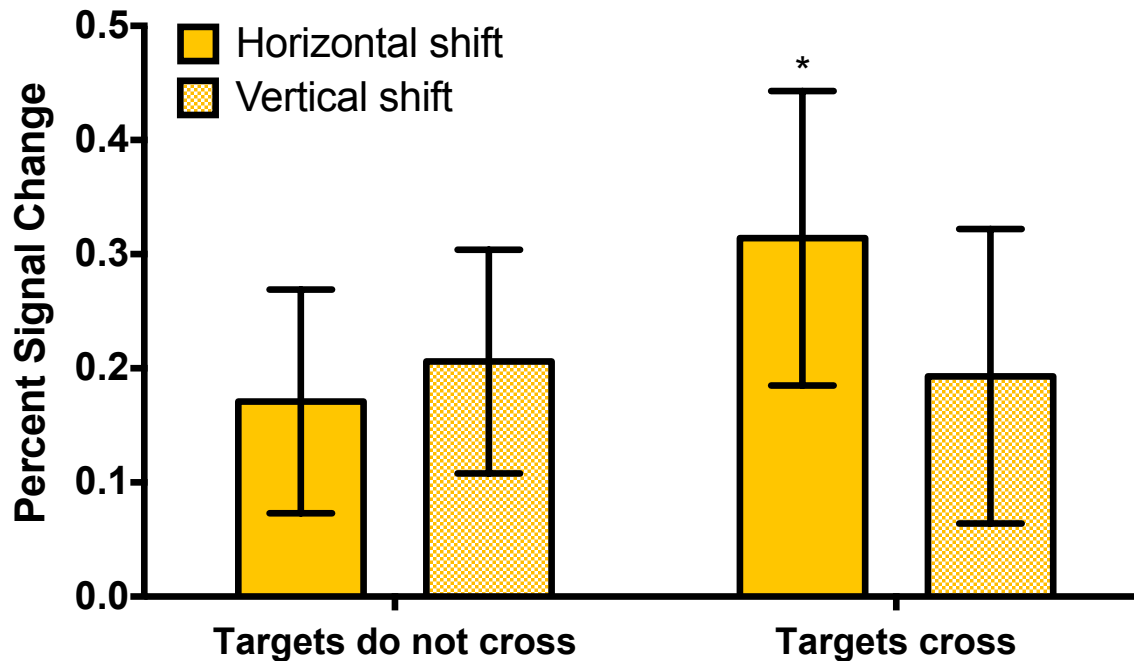

**Figure 49. Attentional orienting at the invalid-horizontal and invalid-vertical target locations as a function of Target Array.** Percent signal change in target-related activity for attentional orienting as a function of Target Array. The error bars represent the standard error of the mean for within-subjects design.

$\eta_p^2 = .20$ ; however, we explored this interaction to examine if any target-related activity varied across retinotopic locations. These data are visualized in Figure 50. A one-way ANOVA was conducted separately for each set of Object and Target Array. All four ANOVAs were not significant, all  $F_s < 1.9$ , all  $p_s > .18$ . However, for the upper left object, the result of an independent samples  $t$ -tests revealed significantly greater target-related activity at the non-crossing invalid-horizontal location ( $M = 0.242$ ,  $p = 0.089$ ) compared to the valid location ( $M = -0.151$ ,  $p = 0.111$ ),  $t(8) = 2.92$ ,  $p = .019$ ,  $d = 0.76$ . Furthermore, there was marginally greater target-related activity at the crossing invalid-horizontal location ( $M = 0.211$ ,  $SEM = 0.177$ ) compared to the valid location ( $M = -0.174$ ,  $SEM = 0.083$ ),  $t(8) = 2.21$ ,  $p = .057$ ,  $d = 0.76$ .

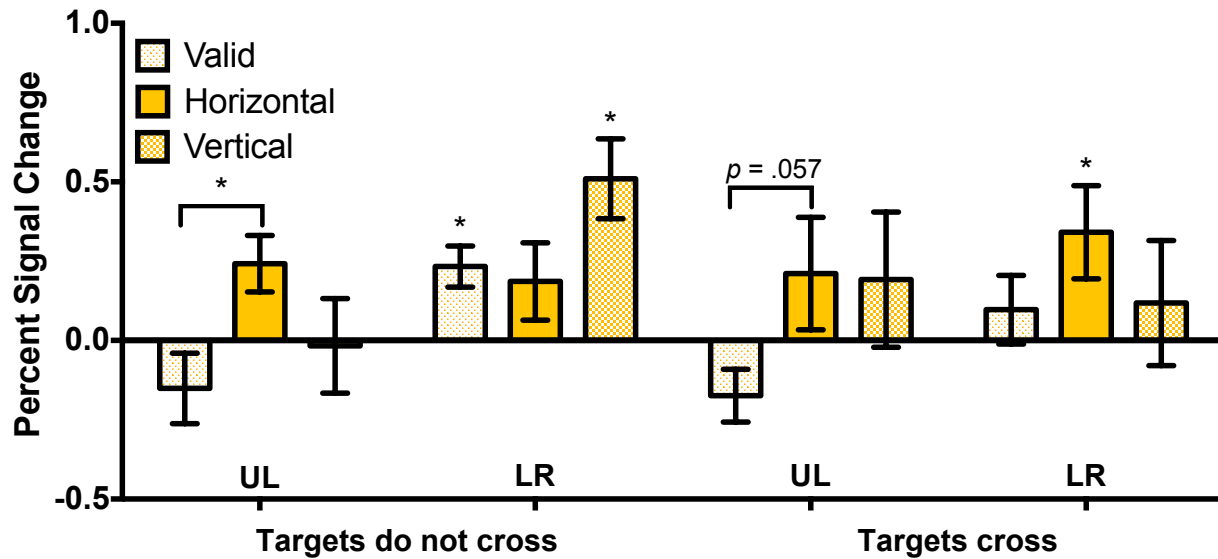

**Figure 50. Retinotopic target-related activity for Object, Target Array, and Shift Direction.** Percent signal change in target-related activity for Shift Direction as a function of Object and Target Array. The error bars represent the standard error of the mean for within-subjects design.

*Target-related activity in the same retinotopic location.* Target-related activity at overlapping retinotopic locations in the upper right and lower left were also analyzed. Results of independent-samples *t*-tests revealed no significant differences in Shift Direction at the upper right location (non-cued horizontal location on the upper left object:  $M = 0.385$ ,  $SEM = 0.172$ ; non-cued vertical location on the lower right object:  $M = 0.021$ ,  $SEM = 0.172$ ),  $t(8) = 1.06$ ,  $p = .320$ ,  $d = 0.52$ , or the lower left location, (non-cued horizontal location on the lower right object:  $M = 0.244$ ,  $SEM = 0.177$ ; non-cued vertical location on the upper left object:  $M = 0.366$ ,  $SEM = 0.177$ ),  $t(8) = 0.34$ ,  $p = .740$ ,  $d = 0.18$  (See Fig. 51).

When these data are partitioned by region, a significant difference is observed for the upper right retinotopic location in V1, such that activity for shifting attention horizontally on the upper left object ( $M = 1.064$ ,  $SEM = 0.311$ ) was significantly increased compared to shifting

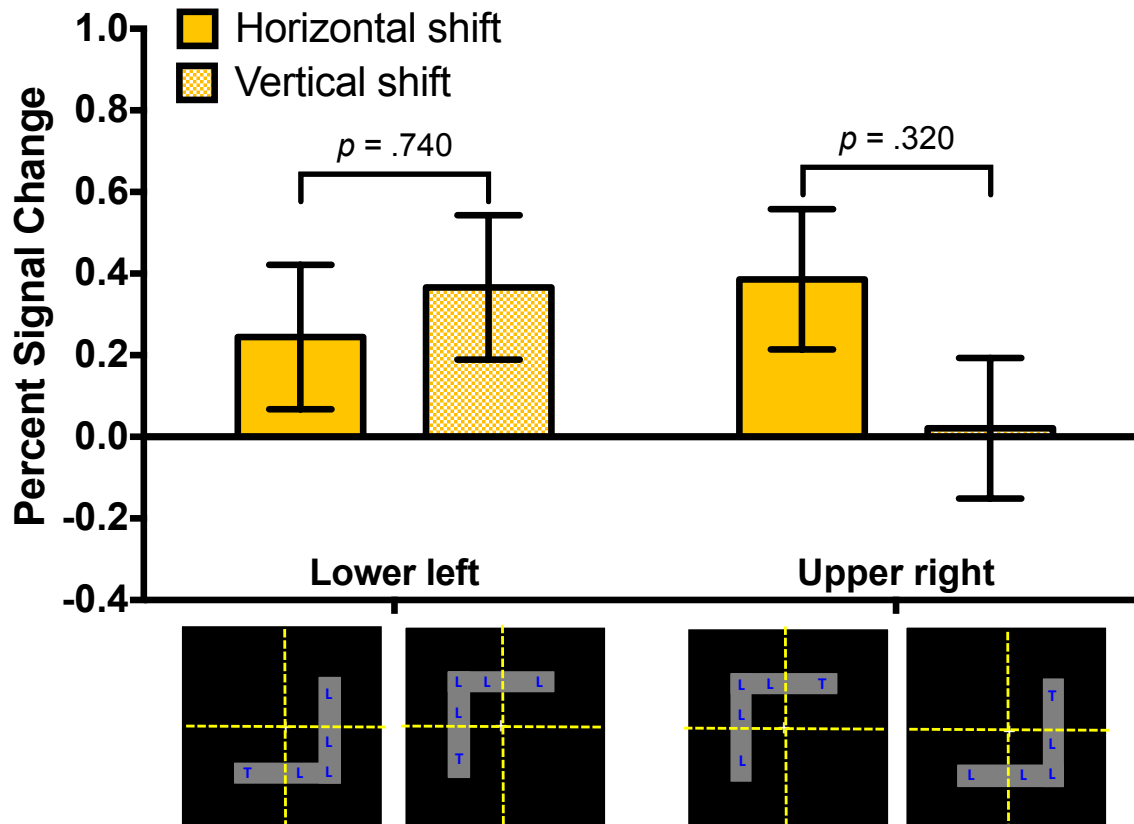
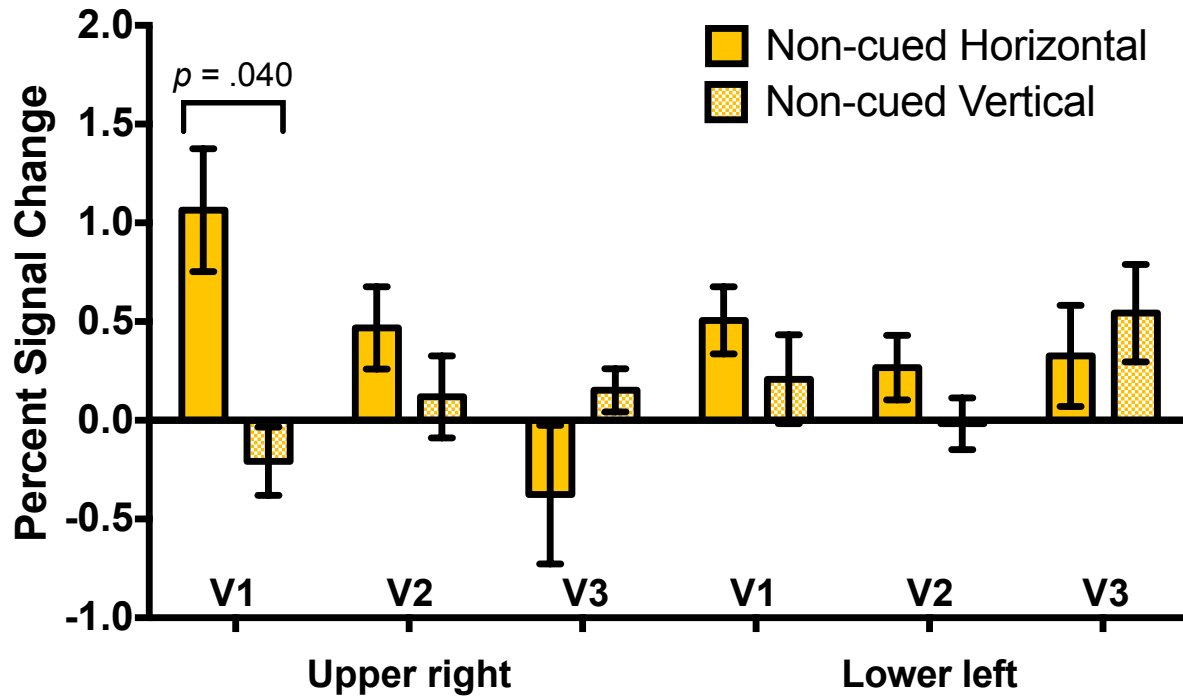

**Figure 51. Target-related activity in the same retinotopic location.** Percent signal change in target-related activity at lower left and upper right retinotopic locations that are both types invalid locations. The error bars represent the standard error of the mean for within-subjects design.

attention vertically on the lower right object ( $M = -0.207$ ,  $SEM = 0.173$ ; See Fig. 52). All other effects were not significant, all  $ts < .1.0$ , all  $ps > .34$ .

### General Discussion

The goal of this experiment was to examine direction-based attention effects in functional cue-related and target-related activity while participants engaged object-based attention. As demonstrated previously in multiple behavioral experiments, shifts of object-based attention to invalid target locations that crossed the visual field meridians resulted in a shift direction anisotropy (SDA) characterized by faster attention shifts to an invalid-horizontal location



**Figure 52. Target-related activity at similar retinotopic locations in V1-V3.** Percent signal change in target-related activity at upper right and lower left retinotopic locations that are both types of non-cued locations. The error bars represent the standard error of the mean for within-subjects design.

compared to an invalid-vertical location. When invalid target locations do not necessitate a shift of object-based attention across the meridians, no SDA emerged, and horizontal shift RTs are statistically equivalent to vertical shift RTs. This pattern of behavior holds true regardless of where an object is located in the visual field. However, as is evident in the current behavioral results, both before and during scanning, two unexpected anomalies arose. First, when targets necessitated shifts of attention across the meridians, participants exhibited the standard SDA effect when the object was positioned in the upper left quadrant. A significant anisotropy was also expected when the object was positioned in the lower right quadrant; but in this case, horizontal shifts of attention were equally as fast as vertical shifts of attention. Second, when targets did not necessitate shifts of attention across the meridians, participants exhibited the

standard non-SDA effect when the object was positioned in the lower right quadrant. No significant SDA was also predicted for the object in the upper left, but a significant difference between horizontal and vertical shifts of attention was present. In sum, participants exhibited only a portion of the predicted behavioral effects in this fMRI experiment. This does not mean, however, that these neuroimaging data are not fruitful. In fact, there are several important data points that emerge from both cue-related and target-related activity.

First, we found differences in cue-related activity. In general, activity related to cue prioritization at the vertex and at non-cued locations did not significantly differ during blocks when invalid target locations did not cross the meridians. This means that attentional resources in response to the cue were prioritized equally to all likely locations of an upcoming target, which happen to be in the same visual field quadrant. Attentional resources following onset of the cue were prioritized unequally in blocks when invalid target locations crossed the meridians. Specifically, there was a significant difference in attentional resource allocation at the non-cued horizontal location in response to cue onset, whereas attentional resources were prioritized equally to the cued location and to the non-cued vertical location. When cue-related activity is analyzed for each object, cue prioritization does not differ for either object during blocks of non-crossing invalid target locations but shows a pattern of unequal prioritization at the non-cued horizontal location in both objects during blocks of crossing invalid target locations. Together, these results map on to two different accounts of object-based attention. The cue-related activity for the non-crossing targets is consistent with the attentional spreading account (Vecera & Farah, 1994; Richard, Lee, & Vecera, 2008) which posits the automatic and equal spreading of attentional resources to all behaviorally relevant target locations. On the other hand, the cue-related activity for the crossing targets is consistent with the attentional prioritization account

(Shomstein & Yantis, 2002, 2004) which is based on attentional resources flexibly by the invalid target locations. Under the latter account, object-based attentional effects, like the SDA, result from the unequal prioritization of attention at the invalid-horizontal location and the invalid-vertical location. The current findings suggest that when presented with an object that constricts both horizontal and vertical shifts of attention within its boundaries, object-based attentional resources are distributed equally to all possible target locations that do not require allocating these resources across the visual field meridians. When attention must be prioritized to target locations that cross the visual field meridians, attentional resources are then distributed unevenly to the non-cued horizontal location relative to the cued and non-cued vertical locations.

Second, we found differences in target-related activity. There were no differences in evoked activity when a target appeared in one of the three possible retinotopic locations of the non-crossing target array. Numerically, targets at the valid location elicited less activity than targets at the invalid locations, but there were no differences between valid and invalid locations or between invalid-horizontal and invalid-vertical locations. However, there is a difference in target-related activity for targets in the crossing target array. Activity at the invalid-horizontal location was significantly greater than activity in the valid location, and there is a trend for greater orienting at the horizontal location than at the vertical location. Again, these patterns of results provide support for both the attentional spreading account (for the non-crossing targets) and attentional prioritization account (for the crossing targets) of object-based attention.

Collectively, these neuroimaging results mimic, to an extent, the basic behavioral SDA. In general, cue-related and target-related activity did not differ significantly for invalid target locations that did not cross the meridians, while there is evidence demonstrating significant differences in activity for invalid target locations that crossed the meridians driven largely by

activity at the horizontal location. These results also provide provisional support to our theory implicating visual system neuroanatomy in the unequal prioritization and allocation of object-based attentional resources. We speculate that horizontal shifts of object-based attention across vertical meridian are enhanced, behaviorally, relative to vertical shifts of object-based attention across the horizontal meridian due to the pooling of attentional resources in each hemisphere by the interhemispheric boundary. Under this theory, horizontal locations do not have to compete with the valid location for attentional resources because each location benefits from its own pool of resources, whereas vertical locations must compete with the valid location since these locations have a shared representation within each hemisphere and, thus, are in direct competition for attentional resources. Few significant activity differences were observed at the non-crossing locations following cue and target onset, indicating that there is not one location within the array that is receiving an unequal, or the majority, of the available attentional resources. For instance, the non-crossing target array in the lower right object experienced no differences in cue-related or target-related activity, which played out in behavioral RTs that showed no difference between horizontal and vertical shifts of attention. Conversely, the crossing target array in the upper left object experienced significant or marginally significant differences in cue-related and target-related effects at the horizontal location. According to this theory, attentional resources are prioritized unequally at these target locations because of increased competition between the valid and vertical locations and reduced competition between the valid and horizontal locations. Thus, reducing competition at the horizontal location as a result of a separate pool of attentional sources manifests as a horizontal advantage SDA.

## CHAPTER 6: Conclusion

Object-based attention results in a prioritization of attentional resources to a cued object versus a non-cued object, known as the same object advantage. Previous work with the standard double-rectangle cueing paradigm (Egly, Driver, & Rafal, 1994) has demonstrated that the same object advantage is inconsistent, small, and unreliable which ultimately draws into question the legitimacy and reliability of object-based attention as a form of visual attentional selection. Additionally, it has been shown that object-based effects vary as a function of object orientation (Pilz et al., 2012). A same object advantage is usually observed with horizontal rectangles and a reversal of the same object advantage (a same object cost) is typically observed with vertical rectangles. These opposing effects may emerge due to the confound between shift direction, object orientation, and object selection. Reallocating object-based resources in the presence of two horizontal rectangles involves constraining horizontal shifts of attention across the vertical meridian within the boundaries of the cued object, whereas vertical shifts of attention must cross the horizontal meridian between cued and non-cued objects, shifting from one object to the other. With two vertical rectangles, horizontal shifts of attention across the vertical meridian must now occur between object boundaries, whereas vertical shifts of attention across the horizontal meridian are now constrained by the boundaries of the cued object. Additionally, previous work suggests that the meridians, themselves, may be the cause of the object orientation effects previously observed (Greenberg et al., 2014)

In order to resolve this confound, we developed an object-based attention cueing paradigm that constrained both horizontal and vertical shifts of attention across the meridians within the boundaries of a single 'L'-shaped object, thus eliminating competition for object resources. When object-based attention shifts are limited to the boundaries of a single object, we

observed a significant enhancement of RTs at an invalidly cued horizontal location relative to an invalidly cued vertical location (the shift direction anisotropy, SDA; Barnas & Greenberg, 2016). Since these two locations are always equidistant from a cued location, RTs to detect a target at either invalidly cued location should, in theory, be equivalent. However, we observed a significant direction-based difference, characterized by a horizontal shift RT advantage. The magnitude of this effect was quite large compared to previous reports of the same object advantage. Additionally, we discovered that the prevalence of this effect was greater than the prevalence of the same object advantage. When two 'L'-shaped objects were present, larger SDAs were discovered on the non-cued object compared to the cued object. Together, this early work suggests that large and widespread object-based effects do exist when the confound between shift direction, object orientation, and object selection is properly controlled. We, therefore, argue that the SDA may be a more practical and sensitive metric of object-based attention compared to the same object advantage.

The focus of this dissertation moved to understanding the shift direction anisotropy as a metric object-based attention. In Chapter 3, we explored whether anisotropic attention shifts are driven by the location of the invalid targets, placement of the object, or both. We accomplished this by systematically juxtaposing meridian crossings of the targets with meridian crossings of the object. In Experiments 1-3B, we discovered that the SDA, in general, emerged due to crossings of the invalid target locations. Regardless of object crossings, the SDA was observed only under conditions in which shifts of object-based attention crossed the visual field meridians. Interesting, when both object boundaries and invalid target locations simultaneously crossed the meridians, the SDA was characterized by the standard horizontal shift RT advantage. When the invalid target locations crossed the meridians but appeared outside of the object boundaries (due

to an object that did not cross the meridians), a reversal of the SDA was observed that was characterized by vertical shift RT advantage. In this particular case, object-based attentional mechanisms may not be utilized properly since the target locations are uncoupled from the boundaries of the object, resulting in degraded object-target integration. Moreover, the vertical shift RT advantage for external target locations may emerge due to greater suppression of attentional mechanisms at the horizontal location relative to the vertical location (conversely, the horizontal shift RT advantage for internal target locations may emerge due to greater enhancement of attentional mechanisms at the horizontal location relative to the vertical location). Nonetheless, there is evidence of directionally dependent shifts of attention when invalid target locations cross the meridians. When the invalid target locations did not require attention shifts across the meridians, no significant SDA was found. Thus, direction-based attention shifts as a result of meridian crossings support the attention prioritization account of object-based selection. Rather than an equal spread of attentional resources within the boundaries of an object to all possible target locations, allocating attentional resources to the horizontal location is prioritized relative to allocating attentional resources to the vertical location.

In Chapter 3, we also conducted two critical control experiments in order to provide unequivocal support to our conclusions. For Experiments 1-3B, the cue-to-target distance differed depending on whether or not the invalid target locations crossed the meridians. Reallocating object-based attention to invalid target locations that did not cross the meridians required shifting attention across a smaller distance compared to the distance required to shift attention to invalid target locations that crossed the meridians. Though we did not feel this influenced our results, as our main interest is always in the difference between equidistant target locations from the exact same cued location, the cue-to-target distance is, nevertheless, a factor

that must be taken into consideration. Therefore, in Experiment 4, the cue-to-target distance was held constant to allow for meridian crossings or non-crossings of the targets without simultaneously manipulating the distance needed to shift from the cued location to the invalidly cued locations. When the distance between cue and target was fixed, we still observed a significant SDA for invalid targets that crossed the meridians and a non-significant SDA for invalid targets that did not cross the meridians, thus strengthening our conclusion that the SDA is driven by meridian crossings on the invalid targets. In Experiment 5, the object was removed from the visual display in order to determine whether the SDA is the result of true object-based attentional selection mechanisms being deployed in this paradigm, or whether the SDA occurs simply due to spatial attention mechanisms. A significant SDA did not emerge in the absence of an object percept, thus suggesting that the SDA emerges due to object-based attentional selection mechanisms and that it is an effect of object-based attention.

In Chapter 4, we causally implicated the visual field meridians in the emergence of the SDA. By enhancing the perceptual visibility of the meridians via local feature contrast manipulations, we found that reallocating object-based attentional resources vertically across the horizontal meridian is impaired relative to reallocating object-based attentional resources horizontally across the vertical meridian. In Experiments 6 and 7, the SDA was subjectively eliminated when the horizontal meridian was enhanced with a perceptually strong local feature contrast manipulation, such as a visible line at 100% contrast. Manipulations of the vertical meridian, however, did not significantly modulate the magnitude of the SDA. Weaker local feature contrast manipulations, such as colored background hemifields (Experiment 8) and illusory contours (Experiment 9) significantly reduced the magnitude of the SDA relative to a vertical meridian enhancement or a no meridian enhancement baseline but were not capable of

completely eliminating the SDA. In Experiment 10, partial enhancements of the meridian, such as highlighting the ends, had no effect at modulating the SDA. Collectively, the results of Chapter 4 demonstrate that the SDA is a malleable object-based effect and is susceptible to perceptual manipulations of the horizontal meridian. Importantly, the results of Chapter 4 also reveal the roles of the meridians in the emergence of the SDA. Across Experiments 6-10, in general, horizontal shifts of attention across the vertical meridian were largely unaffected by any perceptual enhancements, whereas vertical shifts of attention across the horizontal meridian were influenced by strong perceptual enhancements. This suggests that, under standard conditions in which the meridians are not visible, vertical shifts of object-based attention across the horizontal meridian are impaired relative to horizontal shifts of object-based attention across the vertical meridian.

In Chapter 5, we used functional MRI to identify whether cue-related or target-related neural activity also demonstrates direction-based differences. We were able to demonstrate, to some degree, no significant SDA in both cue-related and target-related activity for invalid target locations that did not cross the meridians. Again, this finding provides support for the equal spreading of attentional resources at locations that do not cross the meridians. Evidence of a significant SDA was observed following cue and target onset for invalid target locations that crossed the meridians. Specifically, differences in activity were observed at the invalidly cued horizontal location relative to the validly cued and invalidly cued vertical location. This finding provides support for the unequal prioritization of attentional resources at locations that cross the meridians, and also supports the theory that each cortical hemisphere controls its own pool of attentional resources. Since valid and invalid horizontal locations are represented separately by one hemisphere, reallocating resources to the horizontal location does not experience

competition for attentional resources at the valid location. Valid and invalid vertical locations are represented by the same cortical hemisphere and, therefore, compete with one another for attentional resources from the same pool.

This dissertation proposes a novel method for investigating anisotropic attention shifts of object-based attention that have been previously observed, provides the foundation for a comprehensive investigation into the effects of the visual field meridians on real-world object-based attentional selection, and directly challenges and updates current theories of object-based attention to account for visual field and neuroanatomical constraints. When aspects of the often overlooked confound between shift direction, object orientation, and object selection across the visual field meridians are controlled, large object-based effects are evident which are more consistently and reliably observed within and across individuals. Future work in object-based attentional selection and, more generally, attentional prioritization as a whole must consider the role of the visual field meridians in the reallocation of attentional resources across the visual field. We have consistently reported that reallocating attentional resources vertically across the horizontal meridian is impaired relative to reallocating attentional resources horizontally across the vertical meridian, which mirrors neural activity in sensory visual cortex when prioritizing object-based attention horizontally across the interhemispheric boundary relative to prioritizing object-based attention vertically across the intrahemispheric boundary. Future work should continue exploring the visual field and neural constraints of anisotropic shifts of object-based attention. Additional neuroimaging techniques could reveal the attentional signals of the shift direction anisotropy in intraparietal sulcus and, using neuronal interference techniques (i.e., transcranial magnetic stimulation; TMS), causally test the attentional resource pooling theory.

## REFERENCES

- Abrams, R. A., & Law, M. B. (2000). Object-based visual attention with endogenous orienting. *Perception & Psychophysics*, *62*, 818-833. doi:10.3758/BF0320925
- Al-Janabi, S., & Greenberg, A. S. (2016). Target-object integration, attention distribution, and object orientation interactively modulate object-based selection. *Attention, Perception, & Psychophysics*, *78*, 1968-1984. doi:10.3758/s12414-016-1126-3
- Alvarez, G. A., & Cavanagh, P. (2005). Independent resources for attentional tracking in the left and right visual hemifields. *Psychological Science*, *16*(8), 637-643.
- Anderson, J. E., Cameron, E. L., & Levine, M. W. (2014). A method for quantifying visual field inhomogeneities. *Vision Research*, *105*, 112-120. doi:10.1016/j.visres.2014.09.010
- Atchley, P., & Kramer, A. F. (2001). Object and space-based attentional selection in three-dimensional space. *Visual Cognition*, *8*(1), 1-32.
- Avrahami, J. (1999). Objects of attention, objects of perception. *Perception & Psychophysics*, *61*(8), 1604-1612.
- Baldwin, A. S., Meese, T. S., & Baker, D. H. The attenuation surface for contrast sensitivity has the form of a witch's hat within the central visual field. *Journal of Vision*, *12*, 1-17. doi:10.1167/12.11.23
- Banich, M. T. (1998). The missing link: The role of interhemispheric interaction in attentional processing. *Brain and Cognition*, *36*(2), 128-157.
- Banich, M. T., & Belger, A. (1990). Interhemispheric interaction: How do the hemispheres divide and conquer a task? *Cortex*, *26*(1), 77-94.
- Bateman, D., Eaton, J. W., Wehbring, R., Hauberg, S. (2015). The GNU Octave 4.0 Reference Manual 1/2: Free Your Numbers. London: Samurai Media Limited.
- Barnas, A. J., & Greenberg, A. S. (2016). Visual field meridians modulate the reallocation of object-based attention. *Attention, Perception, & Psychophysics*, *78*, 1985-1997. doi:10.3758/s13414-016-1116-5
- Barnas, A. J. & Greenberg, A. S. (2017). Separable effects of object-based attention: The same-object advantage and the shift direction anisotropy. *The 25<sup>th</sup> Annual Workshop on Object Perception, Attention, and Memory*.
- Behrmann, M., Zemel, R. S., & Mozer, M. C. (1998). Object-based attention and occlusion: Evidence from normal participants and a computational model. *Journal of Experimental Psychology: Human Perception and Performance*, *24*(4), 1011-1036.

- Brainard, D. H. (1997). The Psychophysics Toolbox. *Spatial Vision*, 10, 433–436.  
doi:10.1163/156856897X00357
- Brown, J. M., & Denney, H. I. (2007). Shifting attention into and out of objects: Evaluating the processes underlying the object advantage. *Perception & Psychophysics*, 69, 606-618.  
doi:10.3758/BF03193918
- Cave, K. R., & Bichot, N. P. (1999). Visuospatial attention: Beyond a spotlight model. *Psychonomic Bulletin & Review*, 6, 204-223. doi:10.3758/BF03212327
- Chen, H., & Huang, L. (2015). Solving the paradox between same object advantage and different-object advantage. *Vision Research*, 115, 128-134.  
doi:10.1016/j.visres.2015.08.008
- Chen, Z. (2012). Object-based attention: A tutorial review. *Attention, Perception, & Psychophysics*, 74, 784-802. doi:10.3758/s13414-012-0322-z
- Chen, Z., & Cave, K. R. (2006). Reinstating object-based attention under positional certainty: The importance of subject parsing. *Perception & Psychophysics*, 68, 992-1003.  
doi:10.3758/BF03193360
- Chen, Z., & Cave, K. R. (2008). Object-based attention with endogenous cuing and positional certainty. *Perception & Psychophysics*, 70, 1435-1443. doi:10.3758/PP.70.8.1435
- Clevenger, J., & Beck, D. M. (2014). Refining the resource model: Cortical competition could explain hemifield independence. *Visual Cognition*, 22, 1022-1026.  
doi:10.1080/13506285.2014.960668
- Conci, M., & Müller, H. J. (2009). The “beam of darkness”: Spreading of the attentional blink within and between objects. *Attention, Perception, & Psychophysics*, 71, 1725-1738.  
doi:10.3758/APP.71.8.1725
- Cox, R. W. (1996). AFNI: Software for analysis and visualization of functional magnetic resonance neuroimages. *Computers and Biomedical Research*, 29, 162-173.  
doi:10.1006/cbmr.1996.0014
- Curcio, C. A., Sloan, K. R., Kalina, R. E., & Hendrickson, A. E. (1990). Human photoreceptor topography. *The Journal of Comparative Neurology*, 292(4), 497-523.
- Curcio, C. A., Sloan, K. R., Packer, O., Hendrickson, A. E., & Kalina, R. E. (1987). Distribution of cones in human and monkey retina: Individual variability and radial asymmetry. *Science*, 236(4801), 579-582.
- Dale, A. M., Fischl, B., & Sereno, M. I. (1999). Cortical surface-based analysis. I: Segmentation and surface reconstruction. *Neuroimage*, 9(2), 179-194.

- Davis, G., & Holmes, A. (2005). Reversal of object-based benefits in visual attention. *Visual Cognition, 12*, 817-846. doi:10.1080/13506280444000247
- Duncan, J. (1984). Selective attention and the organization of visual information. *Journal of Experimental Psychology: General, 113*, 501-517. doi:10.1037/0096-3445.113.4.501
- Egley, R., Driver, J., Rafal, R. D. (1994). Shifting visual attention between objects and locations: Evidence from normal and parietal lesion subjects. *Journal of Experimental Psychology: General, 123*, 161-177. doi:10.1037/0096-3445.123.2.161
- Egley, R., Rafal, R., Driver, J., & Starrveveld, Y. (1994). Covert orientating in the split brain reveals hemispheric specialization for object-based attention. *Psychological Science, 5*(6), 380-383.
- Faul, F., Erdfelder, E., Buchner, A., & Lang, A.-G. (2009). Statistical power analyses using G\*Power 3.1: Tests for correlation and regression analyses. *Behavior Research Methods, 41*, 1149-1160. doi:10.3758/BRM.41.4.1149
- Fischl, B., Sereno, M. I., & Dale, A. M. (1999). Cortical surface-based analysis. II: Inflation, flattening, and a surface-based coordinate system. *Neuroimage, 9*(2), 195-207.
- Fortenbaugh, F. C., Sanghvi, S., Silver, M. A., & Robertson, L. C. (2012). Exploring the edges of visual space: The influence of visual boundaries on peripheral localization. *Journal of Vision, 12*, 1-18. doi:10.1167/12.2.19
- Greenberg, A. S. (2009). *Uncertainty as a Guiding Principle in the Strategic Allocation of Attention to Objects* (Doctoral dissertation). Retrieved from ProQuest. (UIM Number: 3410160).
- Greenberg, A. S. & Gmeindl, L. (2008). Strategic control of attention to objects and locations, *Journal of Neuroscience, 28*, 564-565. doi:10.1523/JNEUROSCI.4386-07.2008
- Greenberg, A. S., Hayes, D., Roggeveen, A., Creighton, S., Bennett, P., Sekuler, A., Pilz, K. (2014). Object-based attention is modulated by shifts across the meridians, *Journal of Vision, 14*, 1062. doi:10.1167/14.10.1062
- Greenberg, A. S., Rosen, M., Cutrone, E., & Behrmann, M. (2015). The effects of visual search efficiency on object-based attention. *Attention, Perception & Psychophysics, 77*, 1544-1557. doi:10.3758/s13414-015-0892-7
- Greenberg, A. S., Verstynen, T., Chiu, Y. C., Yantis, S., Schneider, W., & Behrmann, M. (2012). Visuotopic cortical connectivity underlying attention revealed with white-matter tractography. *Journal of Neuroscience, 32*, 2773-2782. doi:10.1523/JNEUROSCI.5419-11.2012

- Harrison, S. J., & Feldman, J. (2009). Perceptual comparison of features within and between objects: A new look. *Vision Research*, *49*, 2790-2799. doi:10.1016/j.visres.2009.08.014
- He, X., Fan, S., Zhou, K., & Chen, L. (2004). Cue validity and object-based attention. *Journal of Cognitive Neuroscience*, *16*, 1085-1097. doi:10.1162/0898929041502689
- Hein, E., Blaschke, S., & Rolke, B. (2016). The influence of object similarity and orientation on object-based cueing. *Attention, Perception, & Psychophysics*, *79*, 63-77. doi:10.3758/s13414-016-1229-x
- Henderson, J. M., & Macquistan, A. D. (1993). The spatial distribution of attention following an exogenous cue. *Perception & Psychophysics*, *53*(2), 221-230.
- Hollingworth, A., Maxcey-Richard, A. M., & Vecera, S. P. (2012). The spatial distribution of attention within and across objects. *Journal of Experimental Psychology: Human Perception and Performance*, *38*, 135-151. doi:10.1037/a0024463
- Holtzman, J. D., Sidtis, J. J., Volpe, B. T., Wilson, D. H., & Gazzaniga, M. S. (1981). Dissociation of spatial information for stimulus localization and the control of attention. *Brain*, *104*(4), 861-872.
- Hubel, D. H., & Wiesel, T. N. (1959). Receptive fields of single neurons in the cat's striate cortex. *Journal of Physiology*, *148*(3), 574-591.
- Kahneman, D., & Henik, A. (1981). Perceptual organization and attention. In M. Kubovy & J. R. Pomerantz (Eds.), *Perceptual Organization* (pp. 181-211). Hillsdale, NJ: Erlbaum.
- Kravitz, D. J., & Behrmann, M. (2008). The space of an object: Object attention alters the spatial gradient in the surround. *Journal of Experimental Psychology: Human Perception & Performance*, *34*, 298-309. doi:10.1037/0096-1523.34.2.298
- Kravitz, D. J., & Behrmann, M. (2011). Space-, object-, and feature-based attention interact to organize visual scenes. *Attention, Perception, & Psychophysics*, *73*, 2434-2447. doi:10.3758/s13414-011-0201-z
- Law, M. B., & Abrams, R. A. (2002). Object-based selection within and beyond the focus of spatial attention. *Perception & Psychophysics*, *64*, 1017-1027. doi:10.3758/BF03194753
- Marino, A. C., & Scholl, B. J. (2005). The role of closure in defining the "objects" of object-based attention. *Perception & Psychophysics*, *67*, 1140-1149. doi:10.3758/BF03193547
- Moore, C. M., Yantis, S., & Vaughan, B. (1998). Object-based visual selection: Evidence from perceptual completion. *Psychological Science*, *9*(2), 104-110.
- Müller, N. G., & Kleinschmidt, A. (2003). Dynamic interaction of object- and space-based retinotopic visual areas. *Journal of Neuroscience*, *23*(30), 9812-9816.

- Nah, J. C., Neppi-Modona, M., Strother, L., Behrmann, N., & Shomstein, S. (2018). Object width modulates object-based attentional selection. *Attention, Perception, & Psychophysics*, *80*, 1375-1389. doi:10.3758/s13414-018-1530-y
- Pan, K., & Eriksen, C. W. (1993). Attentional distribution in the visual field during same-different judgment as assessed by response competition. *Perception & Psychophysics*, *53*(2), 134-144.
- Pelli, D. G. (1997). The VideoToolbox software for visual psychophysics: Transforming numbers into movies. *Spatial Vision*, *10*, 437-442. doi:10.1163/156856897X00366
- Pilz, K. S., Roggeveen, A. B., Creighton, S. E., Bennett, P. J., & Sekuler, A. B. (2012). How prevalent is object-based attention? *PLoS One*, *7*(2): e30693. doi:10.1371/journal.pone.0030693
- Posner, M. I., (1980). Orienting of attention. *The Quarterly Journal of Experimental Psychology*, *23*(1), 3-25.
- Posner, M. I., Snyder, C. R., & Davidson, B. J. (1980). Attention and the detection of signals. *Journal of Experimental Psychology*, *109*(2), 160-174.
- Pylyshyn, Z. W., & Storm, R. W. (1988). Tracking multiple independent targets: Evidence for a parallel tracking mechanism. *Spatial Vision*, *3*(3), 179-197.
- Reppa, I., Schmidt, W. C., & Leek, E. C. (2012). Successes and failures in producing attentional object-based cueing effects. *Attention, Perception, & Psychophysics*, *74*, 43-69. doi:10.3758/s13414-011-0211-x
- Reuter-Lorenz, P. A., & Fendrich, R. (1992). Orienting attention across the vertical meridian: Evidence from callosotomy patients. *Journal of Cognitive Neuroscience*, *2*(3), 232-238.
- Richard, A. M., Lee, H., & Vecera, S. P. (2008). Attentional spreading in object-based attention. *Journal of Experimental Psychology: Human Perception and Performance*, *34*, 842-853. doi:10.1037/0096-1523.34.4.842
- Rouder, J. W., Speckman, P. L., Sun, D., Morey, R. D., & Iverson, G. (2009). Bayesian *t* tests for accepting and rejecting the null hypothesis. *Psychonomic Bulletin & Review*, *16*, 225-237. doi:10.3758/PBR.16.2.225
- Saad, Z. S., Reynolds, R. C., Argall, B., Japee, S., & Cox, R. W. (2004). SUMA: An interface for surface-based intra- and inter-subject analysis with AFNI. *2004 2<sup>nd</sup> IEEE International Symposium on Biomedical Imaging: Nano to Macro*, *2*, 1510-1513. doi:10.1109/ISBI.2004.1398837

- Scalf, P. E., Banich, M. T., & Erickson, A. B. (2009). Interhemispheric interaction expands attentional capacity in an auditory selective attention task. *Experimental Brain Research*, *194*, 317-322. doi:10.1007/s00221-009-1739-z
- Scalf, P. E., Banich, M. T., Kramer, A. F., Narechania, K., & Simon, C. D. (2007). Double take: parallel processing by the cerebral hemispheres reduces attentional blink. *Journal of Experimental Psychology: Human Perception and Performance*, *33*, 298-329. doi:10.1037/0096-1523.33.2.298
- Scholl, B. J. (2001). Objects and attention: The state of the art. *Cognition*, *80*(1-2), 1-46.
- Sereno, A. B., & Kosslyn, S. M. (1991). Discrimination within and between hemifields: A new constraint on theories of attention. *Neuropsychologia*, *29*(7), 659-675.
- Sereno, M. I., Dale, A. M., Reppas, J. B., Kwong, K. K., Belliveau, J. W., Brady, T. J., Rosen, B. R., & Tootell, R. B. (1995). Borders of multiple visual areas in humans revealed by functional magnetic resonance imaging. *Science*, *268*, 889-893. doi:10.1126/science.7754376
- Shomstein, S. (2012). Object-based attention: strategy versus automaticity. *WIREs Cognitive Science*, *3*, 163-169. doi:10.1002/wcs.1162
- Shomstein, S., & Behrmann, M. (2006). Cortical systems mediating visual attention to both objects and spatial locations. *Proceedings of the National Academy of Sciences*, *103*, 11387-11392. doi:10.1073/pnas.0601813103
- Shomstein, S., & Behrmann, M. (2008). Object-based attention: Strength of object representation and attentional guidance. *Perception & Psychophysics*, *70*, 132-144. doi:10.3758/PP.70.1.132
- Shomstein, S., & Yantis, S. (2002). Object-based attention: Sensory modulation or priority setting? *Perception & Psychophysics*, *64*(1), 41-51.
- Shomstein, S., & Yantis, S. (2004). Configural and contextual prioritization in object-based attention. *Psychonomic Bulletin & Review*, *111*, 247-253. doi:10.3758/BF03196566
- Soriano, M., Spillmann, L., & Bach, M. (1995). The abutting grating illusion. *Vision Research*, *36*(1), 109-116.
- Pauszek, J. R., & Gibson, B. S. (2016). High spatial validity is not sufficient to elicit voluntary shifts of attention. *Attention, Perception, & Psychophysics*, *78*, 2110-2123. doi:10.3758/s12414-016-1097-4
- Tootell, R. B., Switkes, E., Silverman, M. S., & Hamilton, S. L. (1988). Functional anatomy of macaque striate cortex. II. Retinotopic organization. *Journal of Neuroscience*, *8*(5), 1531-1568.

- Van Essen, D. C. (1985). Functional organization of primate visual cortex. In A. Peters, & E. G. Jones (Eds.), *Cerebral Cortex, Vol 3* (pp. 259-329). New York: Plenum.
- Van Essen, D. C., Newsom, W. T., & Maunsell, J. H. (1984). The visual field representation in striate cortex of the macaque monkey: Asymmetries, anisotropies, and individual variability. *Vision Research, 24*(5), 429-448.
- Vecera, S. P., & Farah, M. J. (1994). Does visual attention select objects or locations? *Journal of Experiment Psychology: General, 123*(2), 146-160.
- Watson, S. E., & Kramer, A. F. (1999). Object-based visual selective attention and perceptual organization. *Perception & Psychophysics, 61*(1), 31-49.
- Yantis, S. (1992). Multielement visual tracking: Attention and perceptual organization. *Cognitive Psychology, 24*(3), 295-340.

## CURRICULUM VITAE

### CONTACT INFORMATION

Adam J. Barnas  
University of Wisconsin-Milwaukee  
Department of Psychology  
2441 E Hartford Ave.  
Milwaukee, WI 53211  
ajbarnas@uwm.edu

### EDUCATION

- 2014-2019    Doctor of Philosophy  
University of Wisconsin-Milwaukee, Milwaukee, WI
- Program: Neuroscience
  - Department: Psychology
  - Dissertation: *Reexamining object-based visual attention: Understanding the nature of direction-dependent attention shifts*
  - Dissertation Committee: Adam S. Greenberg, Ph.D. (chair), Christine L. Larson, Ph.D., Deborah E. Hannula, Ph.D., Wendy E. Huddleston, Ph.D., and Edgar A. DeYoe, Ph.D.
- 2011-2014    Master of Arts  
University of Dayton, Dayton, OH
- Program: General Psychology
  - Department: Psychology
  - Thesis: *Emotional responses evoked by paintings and classical music in artists, musicians, and novices*
  - Thesis Committee: Susan T. Davis, Ph.D. (chair), Greg C. Elvers, Ph.D., Ronald Katsuyama, Ph.D., and Donald J. Polzella, Ph.D.
- 2007-2011    Bachelor of Science  
University of Illinois at Urbana-Champaign, Urbana, IL
- Majors: Psychology, Molecular & Cellular Biology
  - Minor: Chemistry

### AWARDS, HONORS, AND FELLOWSHIPS

Graduate Student Travel Award, University of Wisconsin-Milwaukee, 2019  
R1 Distinguished Dissertator Fellowship, University of Wisconsin-Milwaukee, 2019-2020  
Graduate Student Travel Award, University of Wisconsin-Milwaukee, 2018  
Graduate Student Excellence Fellowship, University of Wisconsin-Milwaukee, 2018-2019  
Travel Award, The Workshop on Object Perception, Attention, and Memory (OPAM), 2017  
Graduate Student Summer Research Fellowship, University of Wisconsin-Milwaukee, 2015  
Graduate Student Summer Fellowship, University of Dayton, 2013

Graduate Student Summer Fellowship, University of Dayton, 2012  
Dean's List, University of Illinois, 2011  
Honorary Senior 100, University of Illinois, 2011

### **RESEARCH AND TEACHING ASSISTANTSHIPS**

Graduate Teaching Assistantship, University of Wisconsin-Milwaukee, 2017-2019  
Graduate Research Assistantship, University of Wisconsin-Milwaukee, 2016-2017  
Graduate Teaching Assistantship, University of Wisconsin-Milwaukee, 2014-2016  
Graduate Research Assistantship, University of Dayton, 2011-2013

### **RESEARCH EXPERIENCE**

2014-2019     Doctoral Student  
Sensory Neuroscience, Attention, and Perception Laboratory – University of Wisconsin-Milwaukee  
Advisor: Adam S. Greenberg, Ph.D.

2011-2013     Masters Student and Lab Manager  
Memory, Aesthetics, Attention, and Perception Laboratory – University of Dayton  
Advisor: Susan T. Davis, Ph.D.

2011-2013     Graduate Research Assistant and Lab Manager  
Visual-Spatial Perception and Action Laboratory – University of Dayton  
Supervisor: Benjamin R. Kunz, Ph.D.

2010-2011     Undergraduate Research Assistant  
Attention and Perception Laboratory – University of Illinois  
Supervisor: Diane M. Beck, Ph.D.

2009-2011     Undergraduate Research Assistant  
Language and Brain Laboratory – University of Illinois  
Supervisor: Susan M. Garnsey, Ph.D.

### **RESEARCH SKILLS AND TECHNIQUES**

- Psychophysics Toolbox programming in Octave
- Testable programming for web-based experiments
- MRI data pre-processing and analysis using AFNI and SUMA
- Statistics and data analysis using SPSS and R

### **TEACHING EXPERIENCE**

Graduate Teaching Assistant: University of Wisconsin-Milwaukee  
Spring 2018     Research Methods in Psychology, Instructor: Marcellus M. Merritt, Ph.D.

- Fall 2017      Perceptual Processes (Online), Instructor: Adam S. Greenberg, Ph.D.
- Spring 2016    Research Methods in Psychology, Instructor: Marcellus M. Merritt, Ph.D.
- Fall 2015      Research Methods in Psychology (Online), Instructor: Katie E. Mosack, Ph.D.
- Spring 2015    Research Methods in Psychology, Instructor: Marcellus M. Merritt, Ph.D.
- Fall 2014      Psychological Statistics, Instructor: Pamela M. Schaefer, Ph.D.

Course Facilitator and Grader: University of Wisconsin-Milwaukee

- Fall 2019      Perception (Online), Instructor: Peter W. Lenz, Ph.D.  
Clinical Psychology: Science and Practice (Online), Instructor: Han Joo Lee, Ph.D.
- Spring 2019    Neuropsychology, Instructor: Kristin Smith, Ph.D.  
Perception (Online), Instructor: Adam S. Greenberg, Ph.D.  
Perception, Instructor: Peter W. Lenz, Ph.D.  
Hormones and Behavior, Instructor: Karyn M. Frick, Ph.D.
- Fall 2018      Introduction to Psychology, Instructor: Kristin Smith, Ph.D.  
Neuropsychology, Instructor: Kristin Smith, Ph.D.  
Perception, Instructor: Peter W. Lenz, Ph.D.  
Health Psychology, Instructor: Gary J. Stark, Ph.D.
- Spring 2018    Perception, Instructor: Peter W. Lenz, Ph.D.  
Psychology of Race, Ethnicity, and Health, Instructor: Marcellus M. Merritt, Ph.D.

**PUBLICATIONS**

Published or In Press

1. **Barnas, A. J., & Greenberg, A. S. (2016).** Visual field meridians modulate the reallocation of object-based attention. *Attention, Perception, & Psychophysics*, 78(7), 1985-1997. doi:10.3758/s13414-016-1116-5
2. **Barnas, A. J., & Greenberg, A. S. (2019).** Object-based attention shifts are driven by target location, not object placement. *Visual Cognition*, doi:10.1080/13506285.2019.1680587

In Preparation or Submitted

## **INVITED TALKS AND ADDRESSES**

1. **Barnas, A. J.** (2019, July). *Reexamining object-based attention: Disentangling shift direction and object selection yields a new, consistent object-based effect*. Talk given at the Department of Psychology, University of Wisconsin-Madison, Madison, WI.
2. **Barnas, A. J.** (2017, March). *Visual hemifields affect the distribution of object-based visual attention*. Talk given at the Psychological Science Department, Carthage College, Kenosha, WI.
3. **Barnas, A. J., & Kunz, B. R.** (2014, November). *Manipulating context and the biomechanics of locomotion during blind-walking tasks*. Talk given at the Department of Psychology, University of Dayton, Dayton, OH.
4. **Barnas, A. J.** (2013, May). *Aesthetic evaluations evoked by paintings and classical music in artists, musicians, and non-experts*. Talk given at the Department of Psychology, University of Dayton, Dayton, OH.

## **PUBLISHED CONFERENCE ABSTRACTS**

1. **Barnas, A. J., & Greenberg, A. S.** (2019). Independent attentional resources explain the object-based shift direction anisotropy. *Journal of Vision, 19*(10), 268c. doi:10.1167/19.10.268c
2. **Barnas, A. J., & Greenberg, A. S.** (2018). Object-based attention is modulated by shift direction and visual field quadrant. *Journal of Vision, 18*(10), 318. doi:10.1167/18.10.318
3. **Barnas, A. J., & Greenberg, A. S.** (2017). Target location, rather than object location, drives the object-based attention shift direction anisotropy. *Journal of Vision, 17*(10), 1334. doi:10.1167/17.10.1334
4. **Barnas, A. J., & Greenberg, A. S.** (2016). Object-based attention shift direction efficient: Behavior and a model. *Journal of Vision, 16*(12), 699. doi:10.1167/16.12.699
5. **Barnas, A. J., & Greenberg, A. S.** (2015). Shifts of object-based attention differ across visual field meridians. *Journal of Vision, 15*(12), 900. doi:10.1167/15.12.900
6. **Barnas, A. J., & Kunz, B. R.** (2014). Decoupling the biomechanics of locomotion and the direction of spatial updating during blind-walking tasks. *Journal of Vision, 14*(10), 1349. doi:10.1167/14.10.1349

## **CONFERENCE PRESENTATIONS**

1. **Barnas, A. J., & Greenberg, A. S.** (2019, May). *Independent attentional resources explain the object-based shift direction anisotropy*. Poster presented at the 19<sup>th</sup> Annual Meeting of the Vision Sciences Society. St. Petersburg, FL.

2. Bieniewski, D. G., **Barnas, A. J.**, & Greenberg, A. S. (2019, April). *Local judgment effects on object-based attention anisotropies*. Poster presented at the 21<sup>th</sup> Annual Association for Graduate Students in Psychology Research Symposium. University of Wisconsin-Milwaukee, Milwaukee, WI.
3. VandenBosch, E. G. \*, **Barnas, A. J.**, & Greenberg, A. S. (2019, April). *Mixture distribution analysis on object-based attention anisotropies*. Poster presented at the 11<sup>th</sup> Annual UWM Undergraduate Research Symposium. University of Wisconsin-Milwaukee, Milwaukee, WI. (**\*Awarded Outstanding Undergraduate Presentation**)
4. **Barnas, A. J.**, & Greenberg, A. S. (2018, November). *Emphasizing the horizontal meridian eliminates the object-based attention shift direction anisotropy*. Poster presented at the 26<sup>th</sup> Annual Workshop on Object Perception, Attention, and Memory. New Orleans, LA.
5. Shakir, S. A., **Barnas, A. J.**, & Greenberg, A. S. (2018, August). *The effect of visual field quadrants on anisotropic attention shifts with meridian enhancements*. Poster presented at the 10<sup>th</sup> Annual UR@UWM Summer Convocation. University of Wisconsin-Milwaukee, Milwaukee, WI.
6. **Barnas, A. J.**, & Greenberg, A. S. (2018, May). *Object-based attention is modulated by shift direction and visual field quadrant*. Poster presented at the 18<sup>th</sup> Annual Meeting of the Vision Sciences Society. St. Petersburg, FL.
7. VandenBosch, E. G., **Barnas, A. J.**, & Greenberg, A. S. (2018, April). *Manipulating the perceptual visibility of the visual field meridians modulates the object-based attention shift direction anisotropy*. Poster presented at the 10<sup>th</sup> Annual UWM Undergraduate Research Symposium. University of Wisconsin-Milwaukee, Milwaukee, WI.
8. **Barnas, A. J.**, & Greenberg, A. S. (2017, November). *Separable effects of object-based attention: The same object advantage and the shift direction anisotropy*. Poster presented at the 25<sup>th</sup> Annual Workshop on Object Perception, Attention, and Memory. Vancouver, BC. (**Awarded Student Travel Award**)
9. VandenBosch, E. G., **Barnas, A. J.**, & Greenberg, A. S. (2017, August). *Attention shift efficiency varies by visual field quadrant*. Poster presented at the 9<sup>th</sup> Annual UR@UWM Summer Convocation. University of Wisconsin-Milwaukee, Milwaukee, WI.
10. Greenberg, A. S., Al-Janabi, S., & **Barnas, A. J.** (2017, August). *Object-based attention is strategic and dependent on perceptual organization*. Talk given at the 22<sup>nd</sup> Annual Meeting of the Cognitive Science Association for Interdisciplinary Learning. Hood River, OR.
11. **Barnas, A. J.**, & Greenberg, A. S. (2017, May). *Target location, rather than object location, drives the object-based attention shift direction anisotropy*. Poster presented at the 17<sup>th</sup> Annual Meeting of the Vision Sciences Society. St. Petersburg, FL.

12. **Barnas, A. J., & Greenberg, A. S.** (2017, March). *Attention affects cortical magnification estimates of human auditory cortex*. Poster presented at the University of Wisconsin-Milwaukee Neuroscience Spring Symposium. University of Wisconsin-Milwaukee, Milwaukee, WI.
13. **Barnas, A. J., & Greenberg, A. S.** (2016, November). *The object-based shift direction anisotropy may depend on expectations about shifting across visual field meridians*. Poster presented at the 24<sup>rd</sup> Annual Workshop on Object Perception, Attention, and Memory. Boston, MA.
14. **Barnas, A. J., & Greenberg, A. S.** (2016, May). *Object-based attention shift direction efficiency: Behavior and a model*. Poster presented at the 16<sup>th</sup> Annual Meeting of the Vision Sciences Society. St. Petersburg, FL.
15. **Barnas, A. J., & Greenberg, A. S.** (2016, April). *Visual field meridians modulate the reallocation of object-based attention*. Talk given at the 18<sup>th</sup> Annual Association of Graduate Students in Psychology Research Symposium. University of Wisconsin-Milwaukee, Milwaukee, WI.
16. **Barnas, A. J., Potthoff, J., & Greenberg, A. S.** (2016, March). *Effects of attention on cochleotopic mapping of human auditory cortex at 7 Tesla*. Poster presented at the University of Wisconsin-Milwaukee Neuroscience Spring Symposium. University of Wisconsin-Milwaukee, Milwaukee, WI.
17. **Barnas, A. J., & Greenberg, A. S.** (2015, November). *Object-based attention is oriented more efficiently along the horizontal meridian than the vertical meridian*. Poster presented at the 23<sup>rd</sup> Annual Workshop on Object Perception, Attention, and Memory. Chicago, IL.
18. **Barnas, A. J., & Greenberg, A. S.** (2015, May). *Shifts of object-based attention differ across visual field meridians*. Poster presented at the 15<sup>th</sup> Annual Meeting of the Vision Sciences Society. St. Petersburg, FL.
19. **Barnas, A. J., & Kunz, B. R.** (2014, May). *Decoupling the biomechanics of locomotion and the direction of spatial updating during blind-walking tasks*. Poster presented at the 14<sup>th</sup> Annual Meeting of the Vision Sciences Society. St. Petersburg, FL.
20. **Barnas, A. J., & Davis, S. T.** (2014, April). *Emotional responses evoked by paintings and classical music in artists, musicians, and non-experts*. Talk given at the 25<sup>th</sup> Annual Brother Joseph W. Stander Symposium. University of Dayton, Dayton, OH.
21. **Barnas, A. J., & Davis, S. T.** (2013, April). *Characteristics of emotion for paintings and classical music*. Poster presented at the 24<sup>th</sup> Annual Brother Joseph W. Stander Symposium. University of Dayton, Dayton, OH.
22. **Barnas, A. J., & Davis, S. T.** (2013, April). *Aesthetic evaluations and emotional responses evoked by paintings and classical music in artists, musicians, and non-experts*. Poster

presented at the 24<sup>th</sup> Annual Brother Joseph W. Stander Symposium. University of Dayton, Dayton, OH.

23. **Barnas, A. J.**, Meter, L. C., Schwob, J. T., James, J. L., & Kunz, B. R. (2013, April). *The role of visual and proprioceptive limb information in affordance judgments and action capabilities*. Poster presented at the 24<sup>th</sup> Annual Brother Joseph W. Stander Symposium. University of Dayton, Dayton, OH.
24. **Barnas, A. J.**, Meter, L. C., Robie, R. P., Chai, K. Y., & Kunz, B. R. (2013, April). *The effect of graphic quality in virtual environments on the perception of egocentric and exocentric distances*. Poster presented at the 24<sup>th</sup> Annual Brother Joseph W. Stander Symposium. University of Dayton, Dayton, OH.
25. **Barnas, A. J.**, Lynn, N. N., Pytel, L. M., Hart, E. J., & Kunz, B. R. (2013, April). *Decoupling the biomechanics of locomotion and the direction of spatial updating during blind-walking tasks*. Poster presented at the 24<sup>th</sup> Annual Brother Joseph W. Stander Symposium. University of Dayton, Dayton, OH.
26. **Barnas, A. J.**, Hart, E. J., Pytel, L. M., Lynn, N. N., & Kunz, B. R. (2013, April). *The effect of context upon the perception of egocentric and exocentric distances using a walkable human Müller-Lyer illusion*. Poster presented at the 24<sup>th</sup> Annual Brother Joseph W. Stander Symposium. University of Dayton, Dayton, OH.
27. Longacre, K., **Barnas, A. J.**, & Kunz, B. R. (2013, April). *The influence of personal height on the perception of object dimensions and affordance judgments*. Poster presented at the 24<sup>th</sup> Annual Brother Joseph W. Stander Symposium. University of Dayton, Dayton, OH.
28. Kemp, K., Dailey, M., Sismour, P., **Barnas, A. J.**, & Davis, S. T. (2013, April). *Put your money where your mouth is: Feedback reduces overconfidence when betting*. Poster presented at the 24<sup>th</sup> Annual Brother Joseph W. Stander Symposium. University of Dayton, Dayton, OH.
29. Schwob, J. T., Pauszek, J. R., Brown, M. R., Oduwole, P., **Barnas, A. J.**, & Davis, S. T. (2013, April). *The impact of social awareness, empathy, and confidence on blindness to change in facial emotions*. Poster presented at the 24<sup>th</sup> Annual Brother Joseph W. Stander Symposium. University of Dayton, Dayton, OH.
30. O'Grady, C., Vidic, Z. J., Snyder, E. I., Tolson, S. M., **Barnas, A. J.**, & Davis, S. T. (2013, April). *Using a mental rotation task to assess the effect of biasing information on overconfidence and narcissism*. Poster presented at the 24<sup>th</sup> Annual Brother Joseph W. Stander Symposium. University of Dayton, Dayton, OH.
31. Hurlburt, D. A., Lieber, H. L., Wedell, M. A., Rosequist, P. E., Marshall, A. A., **Barnas, A. J.**, & Davis, S. T., (2013, April). *Do measures of ocular gaze correlate with subjective ratings in assessing aesthetic preferences for faces?* Poster presented at the 24<sup>th</sup> Annual Brother Joseph W. Stander Symposium. University of Dayton, Dayton, OH.

32. Sutphin, C., Lang, G. G., Miranda, G., Essien, N., **Barnas, A. J.**, & Davis, S. T. (2013, April). *Detecting critical signals in sustained visual attention tasks using simulated radar screens*. Poster presented at the 24<sup>th</sup> Annual Brother Joseph W. Stander Symposium. University of Dayton, Dayton, OH.
33. Sutphin, C., Lang, G. G., Miranda, G., Essien, N., **Barnas, A. J.**, & Davis, S. T. (2013, April). *Effects of sustained attention on auditory displays, mental workload, and stress*. Poster presented at the 24<sup>th</sup> Annual Brother Joseph W. Stander Symposium. University of Dayton, Dayton, OH.
34. Janosko, L. A., Miranda, G. G., Gammarino, E., Ellinghausen, L., **Barnas, A. J.**, Davis, S. T., & Kunz, B. R. (2013, April). *Spatial intelligence and memory for location in athletes and non-athletes*. Poster presented at the 24<sup>th</sup> Annual Brother Joseph W. Stander Symposium. University of Dayton, Dayton, OH.
35. **Barnas, A. J.**, Peters, K. Y., Schwob, J. T., & Kunz, B. R. (2012, April). *Decoupling the biomechanics of locomotion and the direction of spatial updating during blind-walking tasks*. Poster presented at the 23<sup>rd</sup> Annual Brother Joseph W. Stander Symposium. University of Dayton, Dayton, OH.
36. **Barnas, A. J.**, Longacre, K., Lynn, N., Anderson, N., & Kunz, B. R. (2012, April). *The effect of context upon the perception of egocentric distance using a walkable human Müller-Lyer illusion*. Poster presented at the 23<sup>rd</sup> Annual Brother Joseph W. Stander Symposium. University of Dayton, Dayton, OH.
37. Sitz, A., **Barnas, A. J.**, & Kunz, B. R. (2012, April). *The role of visual and proprioceptive limb information in object size and affordance judgments*. Poster presented at the 23<sup>rd</sup> Annual Brother Joseph W. Stander Symposium. University of Dayton, Dayton, OH.
38. Moran, J., O'Grady, C., **Barnas, A. J.**, & Davis, S. T. (2012, April). *The use of a mental rotation task to assess narcissism and gender bias*. Poster presented at the 23<sup>rd</sup> Annual Brother Joseph W. Stander Symposium. University of Dayton, Dayton, OH.
39. Hurlbert, D. A., Key, K. E., **Barnas, A. J.**, Davis, S. T. (2012, April). *Evaluations of aesthetics of faces in portraits versus photographs*. Poster presented at the 23<sup>rd</sup> Annual Brother Joseph W. Stander Symposium. University of Dayton, Dayton, OH.
40. Kemp, K., Flannery, J., Dailey, M., Sismour, P., Arnett, A., **Barnas, A. J.**, & Davis, S. T. (2012, April). *The relationship between narcissism, overconfidence, and risky behavior*. Poster presented at the 23<sup>rd</sup> Annual Brother Joseph W. Stander Symposium. University of Dayton, Dayton, OH.
41. Adamcik, A., Miranda, G., Janosko, L., Gammarino, E., Devlin, C., **Barnas, A. J.**, & Davis, S. T. (2012, April). *Measuring spatial intelligence and memory for location in athletes*. Poster presented at the 23<sup>rd</sup> Annual Brother Joseph W. Stander Symposium. University of Dayton, Dayton, OH.

42. Sutphin, C., Bernard, B., Bare, S., Essien, N., **Barnas, A. J.**, & Davis, S. T. (2012, April). *Visual vigilance: Detecting critical signals in sustained attention tasks*. Poster presented at the 23<sup>rd</sup> Annual Brother Joseph W. Stander Symposium. University of Dayton, Dayton, OH.

### **UPCOMING CONFERENCE PRESENTATIONS**

1. **Barnas, A. J.**, & Greenberg, A. S. (submitted). *Disentangling shift direction, object orientation, and object selection yields a large, reliable metric of object-based attention*. Abstract submitted to the 20<sup>th</sup> Annual Meeting of the Vision Sciences Society. St. Petersburg, FL.

### **MENTORING**

#### Undergraduate Research Assistants: University of Wisconsin-Milwaukee (2014-present)

Sana Shakir	Dominic Bieniewski	Erin VandenBosch	Souriyo Dishak
Mary Liz Kim	Grace Nicora	Nicole Kashian	Richard Dubbelde III

#### Undergraduate Research Assistants: University of Dayton (2011-2013)

Jessica James	Ellen Snyder	Jeremy Schwob	Katherine Peters
Lauren Pytel	Paulina Rosequist	Cara O'Grady	Natalya Lynn
Joseph Pauzek	Graham Lang	Josh Moran	Catherine Devlin
Peter Oduwole	Ryan Robie	Kristen Kemp	Natalie Anderson
Zachary Vidic	Kar Yen Chai	Megan Dailey	Christian Sutphin
Hannah Lieber	Ellen Hart	Peter Sismour	Daniel Hurlburt
Margaret Wedell	Shea Tolson	Giuseppe Miranda	Kristen Key
Brittany Bernard	Jamie Flannery	Nnimnoabasi Essien	Steven Bare
Kevin Longacre	Arianna Arnett	Adam Sitz	Ashley Adamcik
Laura Janosko	Eric Gammarino	Lauren Ellinghausen	

### **AD HOC REVIEWER**

- *Attention, Perception, & Psychophysics*
- *Experimental Brain Research*
- *Journal of Experimental Psychology: Human Perception and Performance*
- *Quarterly Journal of Experimental Psychology*
- *Psychonomic Bulletin & Review*

### **PROFESSIONAL MEMBERSHIPS**

- Vision Sciences Society
- Association for Psychological Science
- Psychonomic Society
- Cognition, Learning, Attention, and Memory Society (University of Wisconsin-Milwaukee)
- Association of Graduate Students in Psychology (University of Wisconsin-Milwaukee)
- Association of Clinical and Cognitive Neuroscience (University of Wisconsin-Milwaukee)
- Society for Music Perception and Cognition

- Sigma Xi
- Alpha Chi Sigma, Zeta Chapter & Chicago Professional Chapter
- Psi Chi: The National Honor Society in Psychology

### **SPECIAL SKILLS AND TRAINING**

- Spring 2019 Wisconsin AFNI Workshop (University of Wisconsin-Milwaukee)  
Multivariate Pattern Similarity Analysis Workshop (University of Wisconsin-Milwaukee)
- Fall 2018 Milwaukee AFNI Workshop (University of Wisconsin-Milwaukee)
- Spring 2018 Introduction to Research Computing (University of Wisconsin-Milwaukee)  
Introduction to Parallel Programming (University of Wisconsin-Milwaukee)
- Summer 2016 Introduction to Research Programming (University of Wisconsin-Milwaukee)
- Summer 2015 Introduction to Parallel Computing (University of Wisconsin-Milwaukee)  
MRI Safety Training (Medical College of Wisconsin)
- Fall 2014 AFNI Bootcamp (National Institute of Health)  
Responsible Conduct of Research (University of Wisconsin-Milwaukee)  
Human Subjects Research training and CITI certification  
Octave & Psychophysics Toolbox seminar (University of Wisconsin-Milwaukee)

### **DEPARTMENT/UNIVERSITY SERVICE AND COMMUNITY OUTREACH**

- 2017-2019 Vice-President of the Cognition, Learning, Attention, and Memory Society
- 2015 Society for Neuroscience Graduate Student Fair (Chicago, IL)
- 2014-2019 Future Success and Upward Bound summer education programs
- 2014-2019 Meet Milwaukee and Go Milwaukee campus preview programs

### **VOLUNTEER EXPERIENCE**

- 2017-present 88Nine Radio Milwaukee  
Psychonomic Society
- 2016-present Doors Open Milwaukee  
Milwaukee Film & Milwaukee Film Festival
- 2015-present Object Perception, Attention, & Memory workshop