

A MATHEMATICAL APPROACH TO PAINT PRODUCTION

PROCESS OPTIMIZATION

by

Ching Ya Chuang

A Thesis Submitted in
Partial Fulfilment of the
Requirements for the Degree of

Master of Science
in Engineering

at

The University of Wisconsin-Milwaukee

May 2021

ABSTRACT

A MATHEMATICAL APPROACH TO PAINT PRODUCTION PROCESS OPTIMIZATION

by

Ching Ya Chuang

The University of Wisconsin-Milwaukee, 2021

Under the Supervision of

Professor Wilkistar Otieno, UWM

&

Professor Dah-Chuan Gong, Chang Gong University

As the global paint market steadily grows, finding the most effective processing model to increase production capacity will be the best way to enhance competitiveness.

Therefore, this study proposes two production environments commonly used in the paint industry: build-to-order (BTO) and the variation of a configuration-to-order

(CTO), called group production, to schedule paint production. Mixed-Integer Linear

Program (MILP) was solved using genetic algorithms (GA) to analyze two production

environments with various products, different set-up times, and different average

demand for each product. The models determine the number of batches, the size and

product of each batch, and the batch sequence such that the makespan is minimized.

Several numerical instances are presented to analyze the proposed models. The

experimental results show that BTO production completes products faster than group production when products are simple (low variety). However, group production is more applicable to manufacturing diverse products (high variety) and mass production (high volume). Finally, the number of colors has the most significant impact on the two models, followed by the number of product types, and finally the average demand.

TABLE OF CONTENTS

ABSTRACT	ii
TABLE OF CONTENTS	iv
LIST OF FIGURES	vi
LIST OF TABLES	vii
ACKNOWLEDGEMENTS	viii
Chapter 1. Introduction	1
1.1 Overview of global paint market	1
1.2 Overview of Paint manufacturing	5
1.3 Research Objectives and Outline	9
Chapter 2. Literature Review	11
2.1 Production planning	11
2.2 Paint production scheduling.....	14
2.3 Production environment.....	16
2.3.1 Build to order (BTO)	16
2.3.2 Configuration to Order (CTO).....	17
2.3.3 Group production.....	18
2.4 Mixed Integer Linear Programming (MILP)	19
2.5 Research Contributions	21
Chapter 3. Methodology	23
3.1 Problem description	23
3.2 Model Assumptions	30

3.3 Model A	31
3.3.1 Model Variables	31
3.3.2 Objective Function	32
3.3.3 Model Constraints.....	33
3.4 Model B	34
3.4.1 Model Variables	34
3.4.2 Objective Function	36
3.4.3 Model Constraints.....	37
3.5 Genetic Algorithm Procedure	40
Chapter 4. Model Demonstration and Numerical Analysis.....	43
4.1 Model demonstration	44
4.2 Numerical Analysis.....	47
4.2.1 Impact of set-up time on makespan.....	48
4.2.2 Impact of the average demand on the makespan.....	51
4.2.3 Impact of the number of products on makespan.....	53
Chapter 5. Conclusion and Future Work.....	61
5.1 Conclusion	61
5.2 Research limitations and suggestions for future work.....	63
Bibliography.....	65
Appendix.....	68

LIST OF FIGURES

Figure 1 Global paint and coatings industry	2
Figure 2 PPG Industries' revenue.....	2
Figure 3 The percentage of the paints and coatings industry major market segmentation	4
Figure 4 Overall paint production process.....	7
Figure 5 Process batch equals transfer batch	13
Figure 6 Process batch not equal to transfer batch	13
Figure 7 Illustration manufacturing process of model A	25
Figure 8 Illustration process of model B.....	26
Figure 9 One instance of a solution for model A.....	28
Figure 10 One instance of solution for model B.....	29
Figure 11 Two-point crossover mechanism	42
Figure 12 Flow chart of genetic algorithm procedure	42
Figure 13 Makespan diagram of instance for model A.....	45
Figure 14 Gantt chart for model A.....	46
Figure 15 Makespan diagram of instance for model B.....	46
Figure 16 Gantt chart for model B.....	47
Figure 17 Makespan under different set-up times	50
Figure 18 Impact of set-up time on idle time for model B	50
Figure 19 Impact of set-up time on idle time for model A	51
Figure 20 Makespan under different average demand.....	52
Figure 21 Makespan under different number of colors.....	54
Figure 22 Comparison of average demand and colors for model A and model B.....	56
Figure 23 Makespan under different number of product types.....	58
Figure 24 Comparison of average demand and colors for model A and model B.....	60

LIST OF TABLES

Table 1 Batch information of the instance (units).....	26
Table 2 Number of machines in each stage for model A and model B.....	27
Table 3 Setting of machines.....	44
Table 4 Optimal result of model A.....	45
Table 5 Optimal result of model B.....	47
Table 6 Setting for analyzing the impact of the set-up time	49
Table 7 Setting for analyzing the impact of average demand.....	52
Table 8 Setting for analyzing the impact of number of colors.....	55
Table 9 Setting for analyzing the impact of number of product types.....	55

ACKNOWLEDGEMENTS

There are several people I would like to acknowledge their contributions to this Thesis. First, I would like to give my sincere gratitude to my advisor, Dr. Wilkistar Otieno, at the University of Wisconsin- Milwaukee, and Dr. Dah-Chuan Gong, at Chang Gong University. They have given me help by providing valuable suggestions and inspiration for new ideas with extraordinary patience and consistent encouragement. Without their support, the thesis could not be in the present form. I also appreciate my committee members, Dr. Seifoddini (UWM) and Dr. Lacasse (AFIT), who provided constructive suggestions for me and accepted to participate in the defense on Christmas vacation.

Also, I would like to extend my deep gratefulness to my family. They encouraged me to go abroad to study, so I could benefit from a diversity of experiences. My thanks also go to my friends who spend a lot of time accompanying with me during this year.

Thank you!

Chapter 1. Introduction

1.1 Overview of global paint market

The paint and coating industry is one of the specialty chemical industries with a large market. According to the 2018 Market Report, coatings have been shown to have a relatively steady growth, at about 2% per annum since the turn of the century (Pilcher and Rezai, 2018). Paints and coatings are mainly used on buildings, industrial and consumer products, such as automobiles, home appliances and wooden furniture, among other uses. Moreover, an increase in the global coatings market is being driven by an acceleration in worldbuilding construction spending, particularly residential construction, which is expected to increase, especially in North America and Europe.

Driven by an expected increasing demand for coatings used in the production of motor vehicles, durable goods, and industrial maintenance applications, global paint and coatings market expects an approximately 5% compound annual growth rate (CAGR) in 2020, from approximately 42 billion liters valued at about ~EUR 130 billion (~142million USD) in 2017 (Figure 1). Figure 2 shows the revenue of Pittsburgh Plate Glass (PPG) Industries between 2009 and 2019. PPG is one of the Americans Fortune 500 companies and a global supplier of paints, coatings, and specialty materials. The

figure shows that the company’s revenue grew by 38 percent in ten years, generating around 15.1 billion U.S. dollars in 2019 (Garside, 2020).

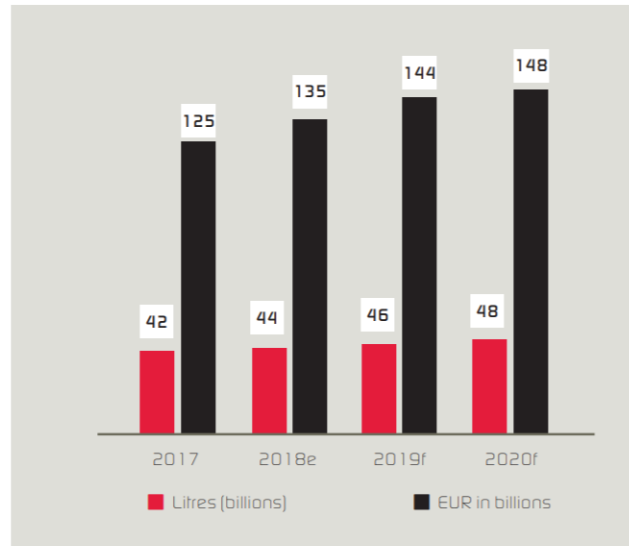

Figure 1 Global paint and coatings industry Volume & Value (2017~2020f):

Source from Pilcher andRezai, 2018¹

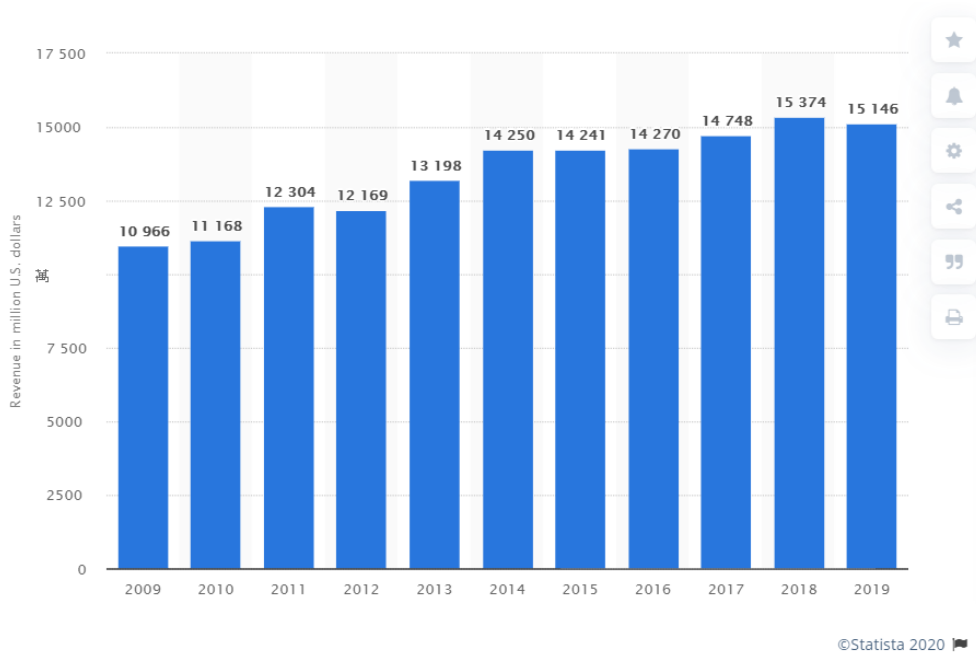

Figure 2 PPG Industries' revenue from 2009 to 2019 (in millions of U.S. dollars):

Source from Garside,2020²

¹ Retrieved August 20,2020, from https://chemquest.com/wp-content/uploads/2018/10/ECJ_10_2018_Market_Report_ChemQuest_Pilcher.pdf

² Retrieved August 20,2020, from <https://www.statista.com/statistics/218763/net-sales-of-ppg-industries/>

Paints and coatings not only have protective and aesthetic functions but also have a variety of functional effects. Paints and coatings have heat insulation properties and they protect surfaces from rust, moisture, acid and alkali, thereby increasing product reliability and longevity. Due to these properties, paints and coatings have found wide usage in construction engineering, transportation equipment, electronic products, household products, in the defense industry, for machinery, furniture, and plastics among other industries.

The paint and coatings market is commonly divided into three categories: architectural (decorative) paints, industrial OEM coatings, and special purpose coatings (Pilcher, 2018). Figure 3 shows the percentage segmentation of the total market value in 2018, which was 24,900 million dollars, into the three paint categories (Pilcher, 2019). The architectural coatings accounts for 61% of the volume, and 50% of the value, within the coatings industry. The industrial OEM and special purpose coatings account for 27% and 12%, respectively, of the volume and 29% and 21%, respectively, of the value (Pilcher, 2019; Morikis, 2019). Therefore, our research discusses major segmentation of coatings and paints industry, architectural paints (S), and the top two paints in industrial OEM, namely general industrial (I) and automobile OEM (C).

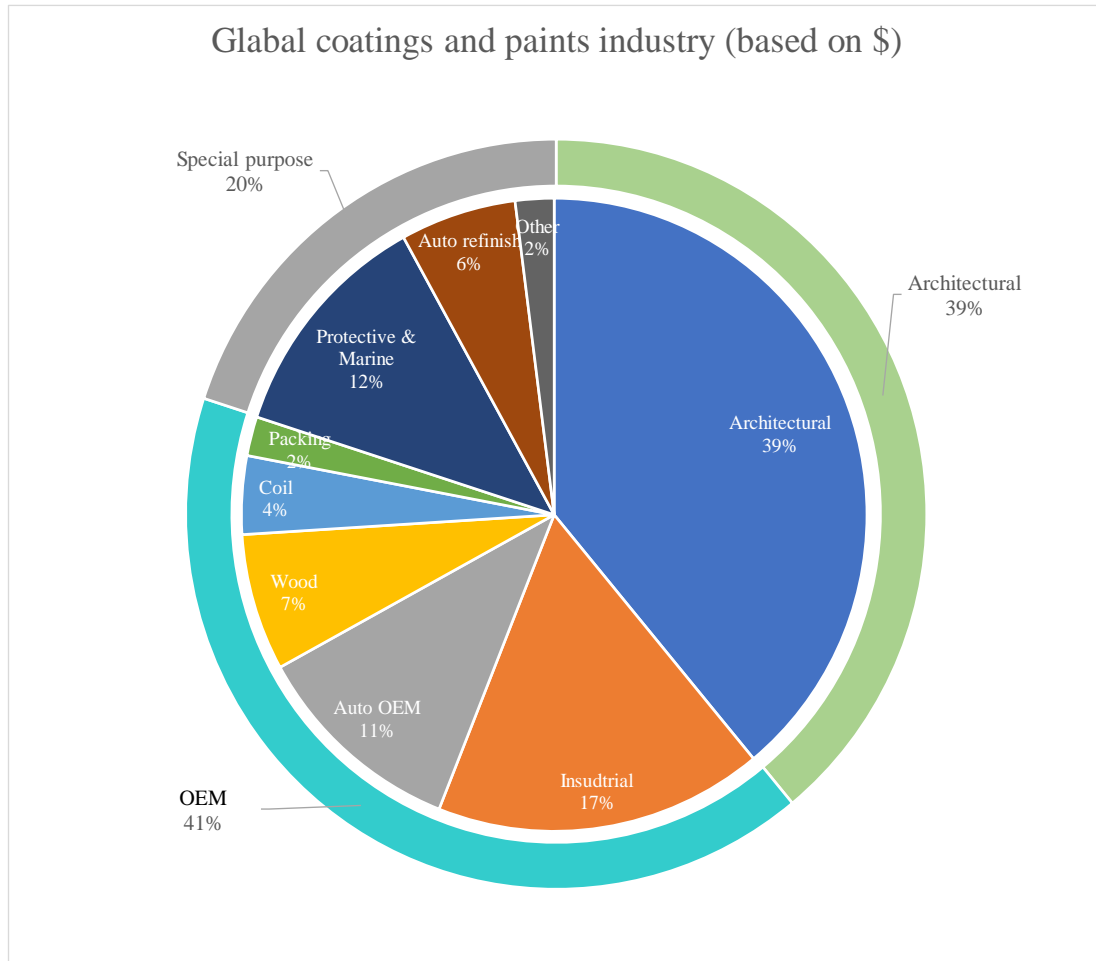

Figure 3 The percentage of the paints and coatings industry major market segmentation, by value (2018), total value in 2017 is 24,900 million dollars

As long as humanity is geared toward improving the quality of life and satisfaction, the need to have better looking cars, homes and appliances will increase and so will the market need of paints and coatings. Besides, with the changes in consumption habits and the combination of the Internet and traditional industries, 夢梵 (2019) pointed out that the manufacturing industry is facing great changes. The new generation of consumers pays attention to freedom and individuality. They not only buy products, but also a sense of "participation" in the customization process. Therefore, the increase in

product differentiation makes the manufacturing industry gradually change from "large-scale standard production" to "mass customization production."

Producers of paints and coatings not only have to meet the diverse customer demands on time but also want to have an upper edge in the fierce competition posed by other producers. The ability to overcome these two challenges is squarely related to the companies' ability to make their production processes optimal using the applicable production based on their product characteristic, and a good schedule. Our research is based on these needs, i.e., to develop and implement a process optimization model.

1.2 Overview of Paint manufacturing

The paint production process generally consists of four stages, namely, scheduling process, manufacturing process, packing process, and delivering. The scheduling process includes receiving orders, splitting orders into sublots, assigning the sublots into batches, and scheduling the batches. Scheduling of the batches is the most important stage in this process because an optimal schedule improves production efficiency.

The manufacturing process of coating and paint includes five stages, named preparing raw materials, pre-mixing, dispersing and grinding, blending, and filtering.³

³ <http://sites.psu.edu/park1115/wp-content/uploads/sites/58665/2016/08/paint-description-jaeyoon-park.pdf>

It mainly involves mechanically stirring and grinding of substances. Except for the resin, normally used in the production of varnishes, which is first refined to a liquid, therefore undergoing a chemical reaction, the rest of the paint producing agents are dissolved into a liquid by solvents.

In the manufacturing process, raw materials are automatically weighed on scales and added into mixing tanks and premixed in a mill base machine. Pigments are powders of typically small size that tend to stick together to form clumps or agglomerates. They are dispersed by the resin and additives that keep them from sticking together. It is worth noting that a good dispersion quality is one of the most challenging attributes of the paint manufacturing process. The paint must be fine and sufficiently stable to achieve the final coloristic properties and stability. If the pigment is unevenly dispersed in the paint, it will cause differences in the color of a given batch. Next, the pigment particles are ground using a horizontal mill to a specific degree of fineness to achieve the desired gloss, which is called grinding. After grinding, additives and defoamers are blended into the paint based on the expected application. At this stage, if required by the formulation, any final additions are made and added in. Finally, to determine the thickness and the viscosity of the paint, the completed product is filtered⁴ (Diplom, 2019).

⁴ <https://www.resene.co.nz/whatispaint.htm>

The final stages are packing and delivering, which involves storage before the paint is transported to the filling process, packaging, and delivering, to customers. In practice, the speed of the filling lines, most of which are automated, is much higher than the speed of the manufacturing lines, and therefore the bottleneck in the paint and coatings industries is usually the initial two processes, namely, scheduling and manufacturing process. This research focuses on improving the first two processes.

Figure 4 shows the overall paint production process.

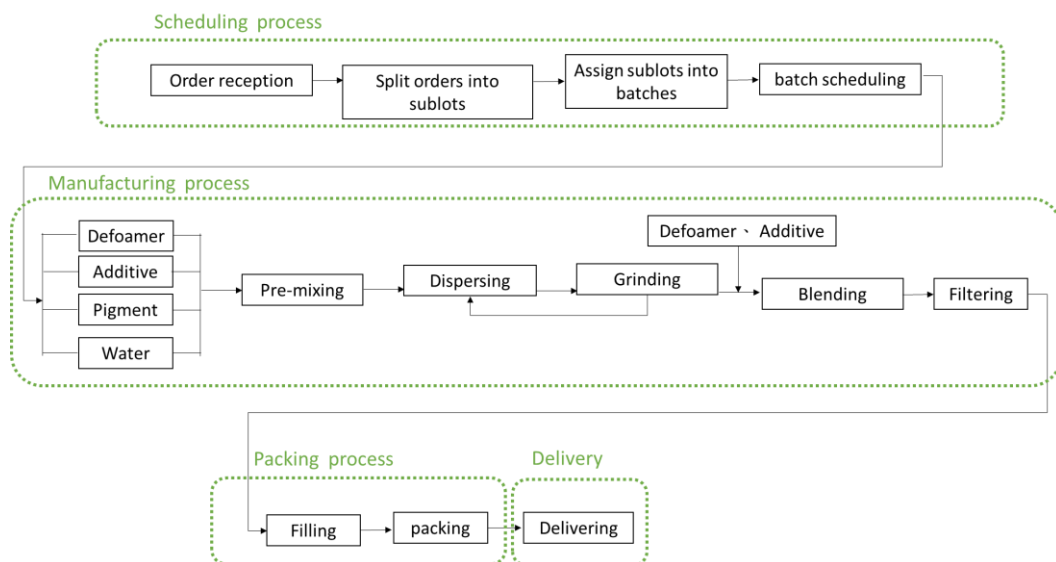

Figure 4 Overall paint production process. Source from: San Nopco⁵

Through visiting paint companies in the US and Taiwan, and interviewing a researcher of the top three paint companies of Taiwan, we learned that the production environment (models) of paint products is usually divided into two categories. The first category is build-to-order (BTO), where products are not built until a confirmed order

⁵ Retrieved August 20, 2020, from <https://www.sannopco.co.jp/eng/products/industry/industry2.php>

for products is received. The customized products are normally using the BTO strategy because the quality is often a significant issue for them but not the efficiency problem (Svensson & Barfod, 2002). Moreover, industries with expensive inventory use this production strategy.

The second category is a configuration-to-order (CTO), where products are assembled and configured by standard semi-finished products until the customer order and the customer-determined specifications or diversified options are received. In this research, we discuss a variation of the CTO strategy, called group production. Usually, the manufacturer forecasts orders based on historical data and orders and stocks up on sub-assembly parts of the finished goods in the CTO production. However, in this research, we discuss deterministic orders and group produce primary colors, such as white, black, red, blue, and yellow paints. There are five dedicated containers for five primary colors, so the same primary color of each batch will be produced in a specific machine. Processing the primary colors to the various final products provides some flexibility in terms of product variations and orders. Even though this production will cause in-process inventory, complete diversified products in small production runs not only strengthen the competitiveness in flexible production but also reduce manufacturing costs by integrated production.

Moreover, it is important to make a schedule before production begins. Profit

increasing along with a good schedule. Accurate estimation of processing times not only helps in on-time job completion but also makes operations more efficient. According to Schultmann, Fröhling, & Rentz, (2006), small amounts of residues from one batch can cause a major change in the color of the following batch, so it will spend a lot of time on cleaning machines if products change frequently. Besides, machines should be washed accurately in all stages to ensure color quality by avoiding color mixing, so the needed efforts for leaning the machines rise significantly with the difference between colors, especially when changes from darker to brighter colors are carried out. Therefore, the set-up time is the other critical issue in the paint industry to schedule an optimal planning.

As discussed above, to make a greater profit, the company should produce in a good schedule with the applicable production environment. We consider that appreciable future growth may cause an undersupply in the paint industry, so this research intends to present mathematical models to make a good schedule and minimize the makespan with two production environments- BTO (Model A) and group production (Model B).

1.3 Research Objectives and Outline

This research is focused on developing and implementing a paint process scheduling model that minimizes makespan in the manufacturing process. The model

is set up as a Mixed Integer Linear Programming problem (MILP) that schedules paint batches and sequences within a defined period.

This study is organized as follows: Chapter 2 reviews the literature related to production planning, paint production scheduling, paint production features, production environments and Mixed Integer Linear Programming (MILP). The research problem is described in Chapter 3, and also presents the mathematical models to formulate the problem objective function. The results of model demonstration and numerical analysis are presented in Chapter 4. Finally, conclusions and future research are discussed in Chapter 5.

Chapter 2. Literature Review

2.1 Production planning

Božek and Werner (2017) presented a MILP model considering a two-stage lot sizing problem with variable sublots to minimize makespan. Products were split into the smallest sublots in the first stage and combined into the maximal sizes of the new sublots without increasing the obtained makespan value in the second stage. Considering variable sublots in the model was the major contribution in their article. However, how to define the multiples of the minimum base size of the subplot sizes is still an article issue to research.

Chen, Zhang, and Tseng (2004) proposed an integrated process planning and production scheduling framework for a mass customization environment following a make-to-order policy. Also, Generic Production Capability (GPC) was proposed to model the production capabilities of resources on meta-level in their paper. The result found that it was impossible to use the GPC data structure when the products offered were highly diversified but could not be organized into product families to customers. Besides, their model was not suitable for the applications where only very few product variants had multiple production alternatives.

Several prior studied scheduled productions by group scheduling approach, which

processed each product family (categorize products that have the same properties or manufacturing attributes such as shape, size, and color, into batches during the manufacturing process) as a single batch, while researchers nowadays focused on the batch scheduling approach that can split each family into smaller batches. Shahvari and Logendran (2018) developed robust meta-heuristics to schedule batch sizes and minimize a linear combination of total weighted completion time and total weighted tardiness of the job. Matin, Salmasi, and Shahvari (2017) propose a mixed-integer linear programming model and several meta-heuristic algorithms based on particle swarm optimization (PSO) to minimize makespan in the flow shop batch processing problem. They considered the restrictions of the maximum number of jobs and total attribute size of jobs. Those studies indicated that the batch scheduling approach got a better solution than a group scheduling approach. Therefore, splitting orders into small batches creation is usually used to help reduce lead time and lead time of delay cost for diversified products in the real industrial world, such as the paint industry (Orcun et al. 1997) (Wang, 2015). Some paint companies, such as Resens and Fluidan, also indicated that paints and coatings were typically made in a batch production (anonymous)⁶⁷. Therefore, we assume batch production for paint manufacturing in our research.

The batch production can be defined in terms of two different concepts, the process

⁶ <https://fluidan.com/manufacturing-of-paint/>

⁷ <https://www.resene.co.nz/whatispaint.htm>

batch, and the transfer batch. Swamidass (2000) defined a process batch is the quantity of a product processed at a work center before that work center is reset to produce a different product. A transfer batch is the number of units that move from one work center to the next. For example, Figure 5 shows the case of both the process batch and the transfer batch of three. Figure 6 shows the case of the process batch of three and transfer batch of one.

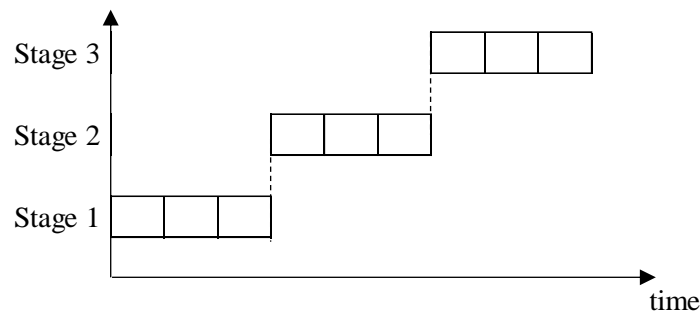

Figure 5 Process batch equals transfer batch

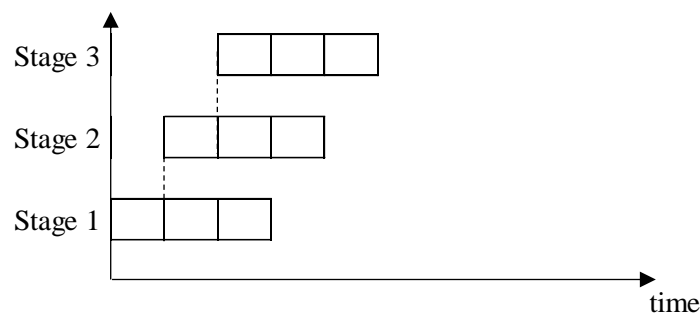

Figure 6 Process batch not equal to transfer batch

However, some batching restrictions are imposed. Yin, Cheng, Wang, and Wu (2019) defined batch production that in general, batches could not be split during manufacturing. Orcun et al. (1997) imposed the limitation that “none of the split batches can enter the next operation after the splitting operation has finished.”

2.2 Paint production scheduling

Wang (2015) presented a MIP model for paint production scheduling. Sixty instances were provided in this research and solved in GurobiTM6.0. The problem was regarded as an NP-hard problem because of the high computation cost. Thus, efficient heuristics was suggested to be developed to analyze this problem.

Many articles focus on different fields of paint production scheduling. Schultmann et al. (2006) thought uncertain time parameters were a major source of interference for production planning. To reduce the negative influence by throughput times and tardiness, they presented an approach using fuzzy sets for detailed scheduling (DS) to adequately consider the uncertain time parameters. Adonyi, Biros, Holczinger, and Friedler (2008) considered the significance of the cleaning cost on makespan. See-Toh (2007) focused on demand forecasting. Through the development of various mathematical time-series clustering and lot-sizing models to address the family product demand forecasting and production planning with variable batch sizes problems. Furthermore, to protect the economic and environment, Dursun and Sengul (2006) took source reduction, recovery, and recycling methods into account to minimize the waste and select an appropriate waste minimization option for the paint plant.

To meet customers' demand on time, several prior researchers focus on minimizing the makespan to make production more effective (Adonyi et al., 2008), (Wang, Kurz,

Mason, and Rashidi, 2019), (Olson, and Schniederjans, 2000), and (Azzi, Faccio, Persona, and Sgarbossa, 2012). Adonyi et al. (2008) studied the relationship between unit cleaning cost and makespan in the paint production problem. They compared the solution of minimal makespan, cleaning cost, and makespan with limited cleaning cost. The result showed that the cleaning cost limitation helps reduce the makespan.

Wang et al. (2019) divided paint production into two stages and considered not only the weights (priorities) of a product but also the concept of product family. Also, they presented a MILP model and heuristics to analyze the problem of integrated batching and lot streaming, which split batches into a lot of sublots and processing those sublots simultaneously over different machines. Their model also determined the number of sublots for each product, the size and the production sequence for each sublot such that the makespan is minimized. All heuristics in their research found an optimal solution for 25% of the examples and found better solutions than the time-limited GurobiTM solver for other examples.

Olson et al. (2000) developed a model to minimize the lateness considering changeovers, scrap, and rework. Thirty-nine percent makespan of reduction is performed by their model. They also indicated the impact of changeover cost. Two methods were provided to optimize their schedules. One was based on the earliest-due-date rule (EDD). It could reduce the amount of scrap and the number of rework batches

but decreased available production time due to several cleaning times. The other was to dedicate production equipment to produce whites (the most popular color of Ceramic Industrial Coatings (CIC)). This way could reduce frequent changeovers and avoid a loss in production.

Azzi et al. (2012) proposed heuristics with a batch aggregation/splitting strategy. They considered job–machines assignment in the first stage and workload leveling in the second stage. They indicated that splitting products and leveling workload can reduce makespan and grouping the same job into the same batch can considerably reduce the setup time.

2.3 Production environment

Wemmerlöv (1984) pointed out that generally, production environments were often characterized as make-to-stock (MTS), build-to-order (BTO), or configuration-to-order (CTO). Since our research is based on customized paints, which require a higher degree of contact, MTS, which involves the least amount of interaction is not discussed in our work.

2.3.1 Build to order (BTO)

BTO was a demand-driven production environment (Holweg and Pil, 2004; Parry and Graves, 2008). Ormeci (2006) defined BTO as the practice of building customized

or standard products as they were ordered and shipping them directly to customers, instead of building-to-forecast and shipping from inventory. There were two advantages to the BTO production environment. First, it could effectively match between products and customer's needs and could enhance satisfaction and loyalty. The other benefit was that it could avoid forecasting uncertain events so that the firm could avoid a high level of inventory and cost increase (Ebrahimia, Moghaddam, & Jolaib, 2018). Hence, when forecasting is difficult, the BTO was in a dominant position.

2.3.2 Configuration to Order (CTO)

Admin (2019) defined CTO as a hybrid production environment in which standard parts and subassemblies were held in inventory, and assembled and configured according to customer requirements. It pushed inventory of components ahead of demand and only assembles products according to customer orders. In this way, firms were not only able to reduce demand uncertainty and shorten their response time to their customers, but also could hold down stocks of finished goods (Benjaafar, and ElHafsi, 2006) (Wemmerlöv, 1984).

Song and Zipkin (2003) mentioned that ATO/CTO could reduce the costs of offering higher product variety by pooling component inventories. However, due to several factors, ATO/CTO systems were difficult to analyze and manage. First, demands for the different components began correlated. Also, the lead time for different

components were different. Finally, order fulfillment was dependent on the availability of multiple components, so continuing to produce one component when there was a shortage of another may do little to improve the ability to fulfill demand.

2.3.3 Group production

As the consumption habits change, diversification and individualization of market demand are increasing such that small-batch production has been one of the important production modes in industry. However, traditionally BTO production consider only similarity of due dates and place less emphasis on process or product similarity, and this causes increased set-up times and decreased efficiency. To enhance the production efficiency and meet the due date constraints in BTO production scheduling, some industries, such as high-/low-voltage electrics (Tao and Xinquan, 2010), printing, textile industry, wood processing, (Cosic, Lazarevic, Rikalovic, and Sremcevic, 2014), classify various parts based on the similarity in their processing technology and then form relatively fewer groups of the parts. In this way, they separate small batch production in former parts group is gathered into larger group production to achieve economic efficiency.

Yu, Ji, Qi, Gu and Tao (2013) proposed a group-based production scheduling approach to minimize the total manufacturing lead time with due date similarity and process similarity. To decide the processing sequence, they grouped the orders based

on the similarity of the due date and then decided on the processing schedule of each group. They indicated that the group production method can reduce the manufacturing lead time due to reduced processing set-up effort. However, how to balance the group size and the time of the due dates of orders is still to be researched.

Tao and Xinquan (2010) studied the group technology in high-/low-voltage which has various products with high sharing parts. They classified and coded the products to form groups that had similar parts. They pointed out that group production could not only reduce the repetition of the process and save a great waste of human resources but also simplify to extend the process planning preparation of new products and diverse products.

Lazarevic et al. (2014) presented a model to show the relationship of group tools and outcomes of the production system. They assigned the parts with the same material to a group and processed them by the same set of machines if the parts with the similar shapes. They also considered the order of releasing products in the production and indicated that product management must be product-oriented rather than process-oriented. The results showed that group production shortened the cycle time and also avoided setup times for each part or product.

2.4 Mixed Integer Linear Programming (MILP)

Linear programming is one of the main methods of solving optimization and one

of the most important scientific inventions in the mid-twentieth century as it has the characteristics of solving models relatively quickly and it is often used to solve a planning problem for allocating limited resources in competitive activities, that is, effectively allocating limited resources to achieve the best goal in a complex environment. The term "linear" means that all the mathematical equations and functions in the problem model are finite lines, and all the variables are linear, so it is called "linear programming." If some variables are restricted to integers in linear programming, it is called "Mixed Integer Linear Programming (MILP)" (Chuang, 2004).

A MILP algorithm is a solver for discrete optimization problems. It has become one of the most widespread methods used for process scheduling problems due to its rigor, flexibility and extensive modeling capability. For example, Floudas and Lin (2005) reviewed several papers on MILP-based approaches for the scheduling of chemical processing systems. Discrete-time models, continuous-time models and some solutions to enhance the computational efficiency for MILP problems were discussed in this paper. However, one of the drawbacks of industrial problems was the generation of a large number of integer variables and constraints.

Baumann et al. (2013) presented a MILP model considering sequence-dependent changeover times, multipurpose storage units with limited capacities, quarantine times,

batch splitting, partial equipment connectivity, and transfer times. The result showed that the model was applicable to only small-sized and moderate-sized problems. Moreover, they found that setting constraints for symmetry-breaking, which were raised from identical batches, storage tanks, processing units, and a preprocessing procedure improved the model performance.

Himmiche, Aubry, Marangé, Pétin (2017) studied the relevance of modeling workshop scheduling problems using a Discrete Event System (DES) approach based on timed automata (TA) and compared it with a classical approach based on Mixed Integer Linear Programming (MILP). He indicated that the main drawback of MILP modeling was its high risk of over-sizing and its need for big modeling efforts for taking into account new constraints.

2.5 Research Contributions

In the past researches on paint scheduling problems, most of them focused on minimizing makespan or reducing costs (Schultmann et al., 2006), (See-Toh, 2007), (Adonyi et al., 2008), (Wang et al., 2019), (Olson et al., 2000), and (Azzi et al., 2012). Although these studies all mentioned to build-to-order production, there were still some differences among them, such as considering parallel machines or single machine in a stage. In practice, to shorten the lead time and quickly respond to customer needs, some companies in Taiwan manufacture paint products using CTO. This concept is

commonly used in other industries, such as the computer industry and the semiconductor industry. Therefore, based on practical application, this research analyzes the grouping-effective and find the applicable environments of CTO and BTO.

In general, the CTO in the paint industry is to produce standard parts, such as primary colors, for the stock by forecasting and then assemble them after receiving customer orders. However, to make the measurement standards consistent, for example, the total processing time of the same product in the two models must be the same, the process of the primary colors is considered. Therefore, this research discusses the CTO production of deterministic demand and group manufacturing of primary colors, called group production.

Chapter 3. Methodology

3.1 Problem description

In this research, we consider two models of a hybrid flow shop. Kurz and Askin (2004) defined a hybrid flow shop as all workpieces having the same processing procedure, each workpiece needing to be processed by more than one machine and following the same sequence. The focus of scheduling is to determine the batch processing sequence and batch size. We define the batch size as the number of the same product processed continuously on the same machine. In both models, customer orders are split into sublots based on product features and accumulating them for some time. Then, determine batches for all demand based on the solution of our models, including products, batch sequence, and batch size. Products in the same batch must be identical. Continuously numbered batches based on the best batch sequence, and batches are then assigned to a machine by the batch sequence in the first stage. Besides, the batch size is an integer whose basic unit is one unit.

There are multiple stages including multiple parallel and identical machines at each stage in both models. Both models mimic batch production, and the process batch size and the transfer batch size are equal to the batch size which is solved by our models. To be noticed that, the process batch size and the transfer batch size in the first stage of

model B should consider the component ratio of each product, so it will be the multiplication of batch size and the ratio of primary colors for its product. In practice, the size of a batch will affect its processing time. Thus, the processing time of each stage will be the multiple of the unit processing time of each batch and the size of each batch. Furthermore, each batch is processed by exactly one machine at each stage and starts process after the machine is cleaned, especially if the product to be processed is different from the previous product processed on the same machine.

According to the report of Charles Ross & Son Company (anonymous)⁸, mixers nowadays is able to combine solids into a liquid while also accomplishing some level of grinding and dispersing right in the same mixing vessel. Thus, we merge pre-mix, and grinding and dispersing into one stage. After deciding on the batch sequence and batch size, model A feeds the required raw materials and allocates the correct proportion of pigment powder according to the batch color requirements for pre-mixing, grinding, and dispersion in the first stage. Next, the required additives are added according to the product type of the batch. Finally, the products are transferred to the packing department after filtering (Figure 7).

⁸ https://www.mixers.com/insights/mti_128.pdf

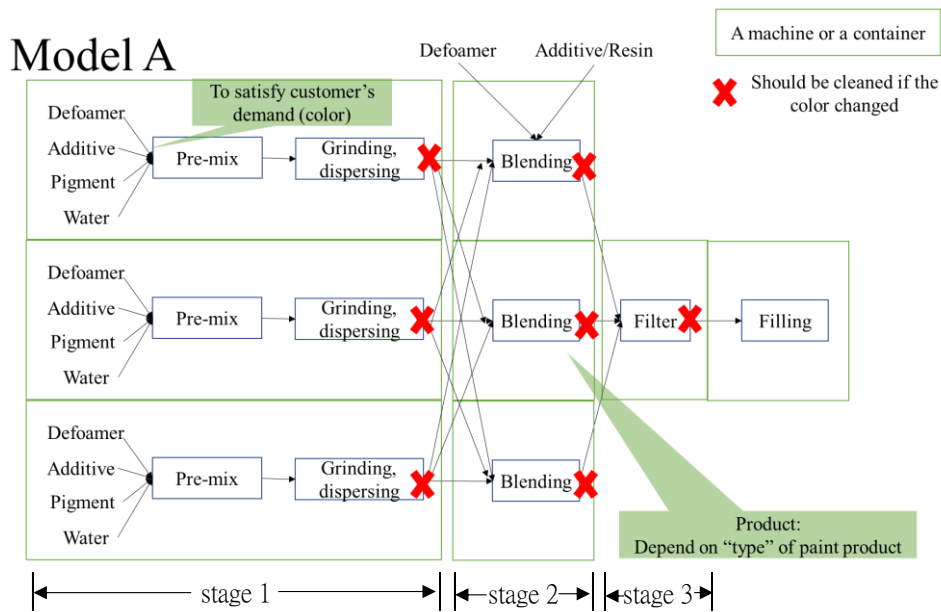

Figure 7 Illustration manufacturing process of model A

Figure 8 describes the manufacturing process of model B. The difference between Model B and Model A is that model B calculates the requirements of each batch for its primary colors, and sequentially pre-mixes, disperses, and grinds the five primary colors in the first stage. Model B has five dedicated containers for primary colors, so there is no cleaning required in the first stage. Once the primary colors for the batch are completed, the batch can go into the next stage. The second stage is color matching (toning) by batch requests. Then, the remaining steps will be the same as the last two steps of model A.

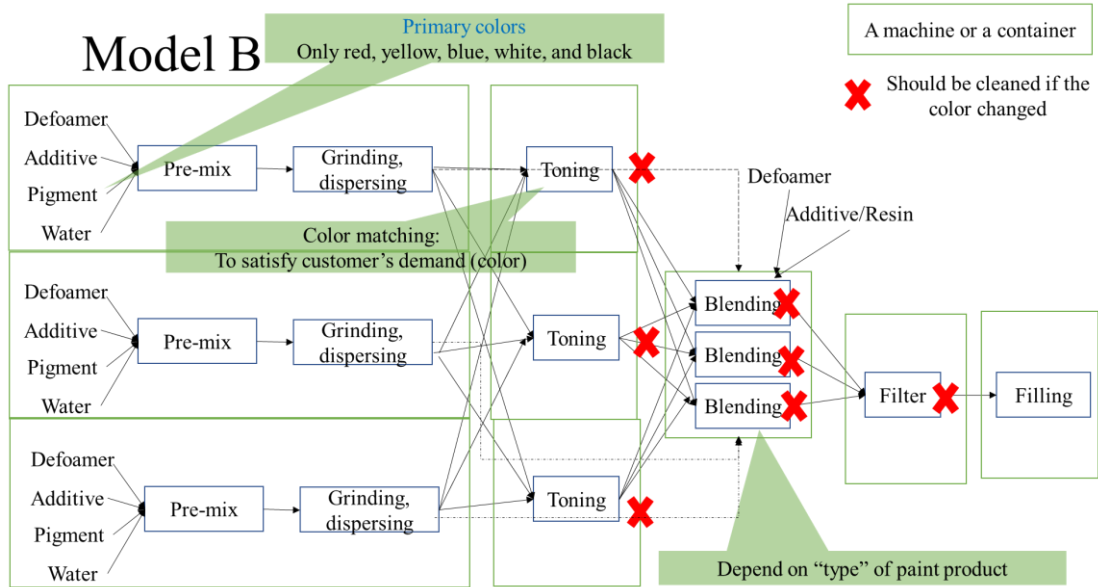

Figure 8 Illustration process of model B

Figure 9 and Figure 10 show an instance of the process of model A and model B.

We assume there are three batches, namely, batch 1: pink C, 10 units; batch 2: orange S, 15 units; batch 3: brown I, 5 units (C, S, I represent different types of products), and the ratio of primary colors for each batch are shown in Table 1. Table 2 shows the number of machines in each stage for two models in this instance. The number of machines have been assigned arbitrarily for computational purposes.

Table 1 Batch information of the instance (units)

batch	product	size	red(R)	yellow (Y)	blue(B)	white (W)	black (Bl)
B1	pink C	10	0.02	0	0	0.98	0
B2	orange S	15	0.08	0.92	0	0	0
B3	brown I	5	0.2	0.7	0	0	0.1

Table 2 Number of machines in each stage for model A and model B

	model A	model B
stage 1	2	5
stage 2	2	2
stage 3	1	2
stage 4		1

The primary colors for batch one are 0.2 units of red (size of batch one*ratio of red primary paints for batch one= $10*0.02=0.2$) and units of white 9.8 (size of batch one *ratio of white primary paints for batch one $10*0.98=9.8$), and so for batches two and three.

For model A, all raw materials of batch one, including 0.2 units of red and 9.8 units of white, are assigned to machine one in the first stage, and all raw materials of batch two are assigned to the other machine which requests the less set-up time. Batch three will be assigned to the machine which has completed processing the previous batch, i.e machine one, and set up before it starts to process if needed. Then, batches will be assigned to the next stage when they complete. Thus, in this instance, batch three starts processing earlier than batch two in stage two because the completion time of batch three in stage one is shorter than that of batch two. Finally, the makespan of this instance will be the maximal completion time of all batches.

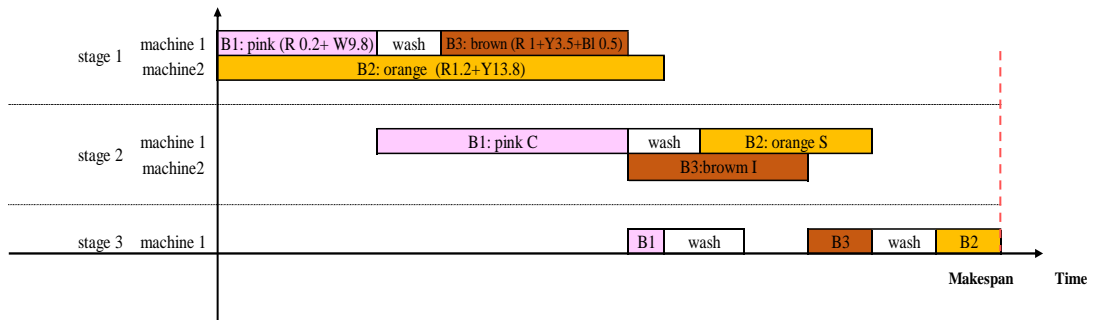

Figure 9 One instance of a solution for model A

For model B, primary colors will be processed by batch sequence. For example, for the red primary color, batch one needs 0.2 units (size of batch one* ratio of red primary paints for batch one= $10*0.02=0.2$), batch two needs 1.2 units ($15*0.08=1.2$), and batch three needs 1 unit ($5*0.2=1$), so the machine for primary red will process 0.2 units, 1.2 units, and 1 unit in that order, and so do other primary colors. The batch will be transferred to the second stage if the primary colors it needs are completed. For example, when red and white primary colors for batch one are completed, batch one will be transferred to stage two and toned to pink. Then, batches continue processing until all batches are completed and the makespan is determined.

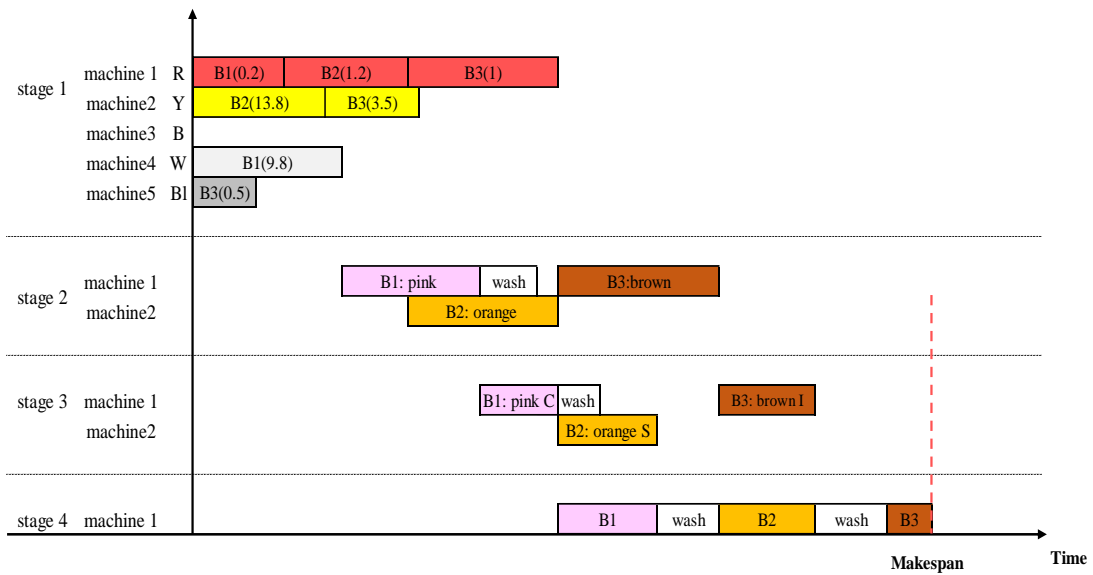

Figure 10 One instance of solution for model B

This research focuses on optimizing the production schedule by minimizing the makespan. The assumptions and two Mixed Integer Linear Programming models are described in the following sections and the results of this instance solved using Genetic Algorithms (GA) are shown in chapter 4.1.

3.2 Model Assumptions

The following assumptions have been made in the optimization model.

1. Demand is deterministic.
2. There is no loss in the process.
3. Products are always produced in a correct proportion, so the defective and excess inventories are not considered.
4. Each batch should not stop the processing in the middle. Also, machine breakdown is not considered.
5. In practice, transfer time is relatively short compared with the processing time. Therefore, the transfer time could be ignored.
6. Because of batch production, all units in a batch should be transferred to the next stage together. Thus, no batch may be processed by more than one machine at a time.
7. In the first stage, raw materials of the batch are assigned to machines by batch sequence.

3.3 Model A

3.3.1 Model Variables

Sets

\mathcal{B} set of batches ; indexed by $b \in \{1,2, \dots, B\}$

\mathcal{S} set of stages ; indexed by $s \in \{1,2, \dots, S\}$

\mathcal{P} set of products ; indexed by $p \in \{1,2, \dots, P\}$

M^s set of machines in stage s ; indexed by $m, m' \in \{1,2, \dots, M^s\}$

Parameters

t_{bp}^{sm} The total processing time of batch b , which belongs to product p , on machine m in stage s .

$T_{p,p'}^s$ Set up time, including cleaning time, between product p to product p' in stage s .

D_p Demand of product p .

u_p^s Unit processing time of product p in stage s .

Variables

$z_{b,b'}^{sm}$ =1, if batch b is processed immediately after a batch b' on machine m in stage s ; 0, otherwise.

r_{bp}^{sm} The starting time of batch b , which belongs to product p , on machine

m in stage s.

c_{bp}^{sm} The completion time of batch b, which belongs to product p, on machine m in stage s.

Decision Variables

n_{bp} Size of batch b, which belongs to product p.

B A maximum number of batches.

3.3.2 Objective Function

Our research objective is to minimize the makespan over all types of products during the manufacturing planning horizon. The makespan minimizing function is shown in (1).

$$\begin{aligned} \text{Min } C_{max} &= \text{Min} [\text{Max } c_{bp}^{sm}] & (1) \\ &= \text{Min} \{ \text{Max} \{ \sum_{b' \in \mathcal{B}} z_{b,b'}^{sm} \cdot \{ c_{b'p'}^{sm} + T_{p,p'}^s + \max[0, c_{bp}^{s-1,m'} - c_{b'p'}^{sm}] \} + u_p^s \cdot n_{bp} \} \} \end{aligned}$$

- ***Completion time: the time that particular batch is to be finished***

$$c_{bp}^{sm} = r_{bp}^{sm} + t_{bp}^{sm}, \forall b \in \mathcal{B}, p \in P, s \in S, m \in M^s$$

- ***Starting time: the time that particular batch can be processed.***

$$\begin{aligned} r_{bp}^{sm} &= \sum_{b' \in \mathcal{B}} z_{b,b'}^{sm} \cdot c_{b'p'}^{sm} + \sum_{b' \in \mathcal{B}} z_{b,b'}^{sm} \cdot T_{p,p'}^s + \sum_{b' \in \mathcal{B}} z_{b,b'}^{sm} \\ &\quad \cdot \max[0, c_{bp}^{s-1,m'} - c_{b'p'}^{sm} - T_{p,p'}^s] \end{aligned}$$

$$= \sum_{b' \in \mathcal{B}} z_{b,b'}^{sm} \cdot \left\{ c_{b',p'}^{sm} + T_{p,p'}^s + \max \left[0, c_{bp}^{s-1,m'} - c_{b',p'}^{sm} - T_{p,p'}^s \right] \right\}, \forall b, b' \in \mathcal{B}, p, p' \in P, s \in S, m, m' \in M^s$$

- **Processing time: the time that particular batch takes to complete a prescribed stage.**

$$t_{bp}^{sm} = u_p^s \cdot n_{bp}, \forall b \in \mathcal{B}, p \in P, s \in S, m \in M^s$$

3.3.3 Model Constraints

- **Batch constraints:**

$$\sum_{p \in P} n_{bp} = \text{Max}[n_{b1}, \dots, n_{bp}], \forall b \in \mathcal{B}, p \in P \quad (2)$$

Constraint (2) ensures that each batch belongs to only one product.

$$\left(r_{bp}^{1m} - \sum_{b' \in \mathcal{B}} T_{p,p'}^1 \cdot z_{b,b'}^{1m} \right) - \left(r_{b-1,p'}^{1m'} - \sum_{b' \in \mathcal{B}} T_{p,p'}^1 \cdot z_{b-1,(b-1)'}^{1m'} \right) \geq 0, \quad (3)$$

$$\forall b \in \mathcal{B}, p, p' \in P, m \in M^s$$

Constraint (3) ensures that in the first stage, batch b-1 should be assigned to a machine no later than batch b.

$$\sum_{m \in M^s} c_{bp}^{sm} - \sum_{m' \in M^s} c_{bp}^{s-1,m'} > 0, \forall b \in \mathcal{B}, p \in P, s \in S \quad (4)$$

Constraint (4) ensures that once the batch is processed, it must be produced until it completed.

$$\sum_{m \in M^s} t_{bp}^{sm} = \text{Max}[t_{bp}^{s1}, \dots, t_{bp}^{sm}], \forall b \in \mathcal{B}, p \in P, m \in M^s, s \in S \quad (5)$$

Constraint (5) ensures that each batch is processed on only one machine.

- **Other constraints:**

$$D_p = \sum_{b \in \mathcal{B}} n_{bp}, \forall p \in P \quad (6)$$

Constraint (6) makes sure that customer's demand is satisfied in any stage.

$$\sum_{b' \in \mathcal{B}} z_{b,b'}^{sm} = 1, \forall b \in \mathcal{B}, s \in S, m \in M^s \quad (7)$$

Constraint (7) ensures that there is only one batch to be processed before batch b.

- **Non-negativity and Integrality constraints:**

$$t_{bp}^{sm}, T_{p,p'}^s, \lambda^s, D_p, u_p^s, r_{bp}^{sm}, c_{bp}^{sm}, n_{bp} \geq 0, \forall b \in \mathcal{B}, p, p' \in P, s \in S, m \in M_s \quad (8)$$

$$z_{b,b'}^{sm} \in \{0,1\} \forall b \in \mathcal{B}, p \in P, s \in S, m \in M_s \quad (9)$$

Constraint (8) and constraint (9) are non-negativity and integrality constraints, respectively.

3.4 Model B

3.4.1 Model Variables

Sets

\mathcal{B} set of batches ; indexed by $b \in \{1,2, \dots, B\}$

\mathcal{W} set of primary colors; indexed by $w \in \{1,2,3, \dots, W\}$

\mathcal{P} set of products; indexed by $p \in \{1,2,3, \dots, P\}$

\mathcal{S} set of stages; indexed by $s \in \{1, 2 \dots, S\}$

M^s set of machines in stage s; indexed by $m \in \{1,2,3, \dots, M^s\}$

Parameters

- t_{bp}^{sm} The processing time of batch b , which belongs to product p , on machine m in stage s . $s \neq 1$
- t_{bpw}^{1m} The processing time of primary color w for batch b on machine m in stage one.
- $T_{p,p'}^s$ Set up time between product p and product p' in stage s .
- D_p Demand of product p .
- u_w^1 Unit processing time of primary color w in stage one.
- u_p^s Unit processing time of product p in stage s . $s \neq 1$
- α_{pw} The ratio of primary colors w for product p .

Variables

- $z_{b,b'}^{sm}$ =1, if batch b is processed immediately after batch b' on machine m in stage s ; 0, otherwise.
- r_{bp}^{sm} The starting time of batch b , which belongs to product p , on machine m in stage s . $s \neq 1$
- r_{bpw}^{1m} The starting time of primary color w for batch b on machine m in stage one.
- n_{bpw} Size of primary color w for batch b .
- c_{bp}^{sm} The completion time of batch b , which belongs to product p , on

machine m in stage s . $s \neq 1$

c_{bpw}^{1m} The completion time of primary color w for batch b on machine m in stage one.

Decision Variables

n_{bp} Size of batch b , which belongs to product p .

B A maximum number of batches.

3.4.2 Objective Function

Our research objective is to minimize the makspan over all types of products during the manufacturing planning horizon. The makespan minimizing function is shown in (10).

$$\begin{aligned} \text{Min } C_{max} &= \text{Min} [\text{Max } c_{bp}^{sm}] & (10) \\ &= \text{Min} \{ \text{Max} \{ \max [\sum_{b=1}^{b-1} (\alpha_{bw} \cdot n_{bp}) \cdot u_w^{s-1}] + \sum_{b' \in \mathcal{B}} Z_{b,b'}^{sm} \cdot \{c_{b',p'}^{sm} + T_{p,p'}^s + \\ &\max [0, c_{bf}^{s-1,m'} - c_{b',p'}^{sm} - \sum_{b' \in \mathcal{B}} Z_{b,b'}^{sm} \cdot T_{p,p'}^s] \} + n_{bp} \cdot u_p^s \} \} \end{aligned}$$

- **Completion time: the time that particular batch is to be finished.**

$$c_{bp}^{sm} = r_{bp}^{sm} + t_{bp}^{sm}, \forall b \in \mathcal{B}, p \in P, s \in S, s \neq 1, m \in M^s$$

$$c_{bpw}^{1m} = \sum_{b=1}^b t_{bpw}^{1m}, \forall b \in \mathcal{B}, p \in P, w \in W, m \in M^1$$

- **Starting time: the time that particular batch can be processed.**

$$r_{bpw}^{1m} = \sum_{b=1}^{b-1} t_{bpw}^{1m}, \forall b \in \mathcal{B}, w \in W, m \in M^1$$

$$\begin{aligned}
r_{bp}^{sm} &= \max[c_{b_{pw}}^{s-1,m'}] + \sum_{b' \in \mathcal{B}} z_{b,b'}^{sm} \cdot c_{b',p'}^{sm} + \sum_{b' \in \mathcal{B}} z_{b,b'}^{sm} \cdot T_{p,p'}^s + \sum_{b' \in \mathcal{B}} z_{b,b'}^{sm} \\
&\quad \cdot \max \left[0, c_{bf}^{s-1,m'} - c_{b',p'}^{sm} - \sum_{b' \in \mathcal{B}} z_{b,b'}^{sm} \cdot T_{p,p'}^s \right] \\
&= \max[c_{b_{pw}}^{s-1,m'}] + \sum_{b' \in \mathcal{B}} z_{b,b'}^{sm} \\
&\quad \cdot \left\{ c_{b',p'}^{sm} + T_{p,p'}^s \right. \\
&\quad \left. + \max \left[0, c_{bf}^{s-1,m'} - c_{b',p'}^{sm} - \sum_{b' \in \mathcal{B}} z_{b,b'}^{sm} \cdot T_{p,p'}^s \right] \right\}, \forall b \in \mathcal{B}, p, p' \\
&\quad \in P, w \in W, s \in S, s \neq 1, m, m' \in M^s
\end{aligned}$$

- **Processing time: the time that particular batch takes to complete a prescribed stage.**

$$t_{bp}^{sm} = n_{bp} \cdot u_p^s, \forall b \in \mathcal{B}, p \in P, s \in S, s \neq 1, m \in M^s$$

$$t_{b_{pw}}^{1m} = n_{b_{pw}} \cdot u_w^1 = (\alpha_{pw} \cdot n_{bp}) \cdot u_w^1, \forall b \in \mathcal{B}, p \in P, w \in W, m \in M^1$$

3.4.3 Model Constraints

- **Batch constraints:**

$$\sum_{p \in P} n_{bp} = \text{Max}[n_{b1}, \dots, n_{bp}], \forall b \in \mathcal{B}, p \in P \quad (11)$$

Constraint (17) ensures that each batch belongs to only one product.

$$r_{b_{pw}}^{1m} - r_{b',p',w}^{1m} \geq 0, b' > b, \forall b, b' \in \mathcal{B}, p, p' \in P, w \in W, m \in M^1 \quad (12)$$

Constraint (12) ensures that batches of primary colors should be processed in sequence in stage one. In other words, for the same primary color, batch b should not

be processed earlier than batch b'.

$$\sum_{m \in M^s} c_{bp}^{sm} - \max[c_{bpw}^{1m'}] > 0, \forall b \in \mathcal{B}, p \in P, w \in W, s \in S, s \neq 1, m' \in M^1 \quad (13)$$

$$\sum_{m \in M^s} c_{bp}^{sm} - \sum_{m' \in M^s} c_{bp}^{s-1, m'} > 0, \forall b \in \mathcal{B}, p \in P, s \in S, s \neq 1 \quad (14)$$

Constraint (14) and constraint (15) ensure that once the batch is processed, it must be produced until it completed.

$$\sum_{m \in M^s} t_{bp}^{sm} = \text{Max}[t_{bp}^{s1}, \dots, t_{bp}^{sm}], \forall b \in \mathcal{B}, p \in P, m \in M^s, s \in S, s \neq 1 \quad (15)$$

Constraint (16) ensures that each batch is processed on only one machine.

● **Other constraints:**

$$D_p = \sum_{b \in \mathcal{B}} n_{bp}, \forall p \in P \quad (16)$$

Constraint (11) makes sure that customer's demand is satisfied in any stage.

$$\sum_{b' \in \mathcal{B}} z_{b, b'}^{sm} = 1, \forall b \in \mathcal{B}, s \in S, m \in M^s \quad (17)$$

Constraint (14) ensures that there is only one batch to be processed before batch b.

$$\sum_{w \in W} \alpha_{pw} = 1, \forall p \in P \quad (18)$$

Constraint (13) ensures that each product is composed of five primary colors.

● **Non-negativity and Integrality constraints:**

$$r_{bp}^{sm}, r_{bpw}^{1m}, t_{bp}^{sm}, t_{bpw}^{1m}, \lambda^s, T_{p, p'}^s, c_{bp}^{sm}, c_{bpw}^{1m}, D_p, u_w^1, u_p^s, n_{bp}, n_{bpw}, \alpha_{pw} \geq 0, \quad (19)$$

$$\forall b \in \mathcal{B}, w \in W, p, p' \in P, s \in S, s \neq 1, m \in M^s$$

$$z_{b, b'}^{sm} \in \{0, 1\}, \forall b, b' \in \mathcal{B}, s \in S, m \in M^s \quad (20)$$

Constraint (18) and constraint (19) are non-negativity constraints and integrality,

respectively.

3.5 Genetic Algorithm Procedure

To overcome the computational complexity inherent in the MILP formulation, we solve the mathematical model using the genetic algorithm (GA) approach. GA is one of the most frequently adopted meta-heuristic approaches used for scheduling problems (Ezra and Weihang, 2016), (Kim, Song, and Morrison, 2013).

Before starting to use GA, we will first process the confirmed demand. We set the minimum base size as one, so all demand is divided into single basis. In the GA procedure, the first step is to represent a solution of the problem as a chromosome. Each chromosome is a $2 \times N$ vector of integers (N is the number of total demand), and the first column is the product color and the second column is the product type. We set 50 chromosomes in each population. Then, encoding genetic material and the initial population of chromosomes is randomly generated. The same products, which share color and type are continuously combined into a batch and calculate the fitness of each chromosome. The fitness, which in the case of our study, is the objective function value, that is the makespan.

At each iteration of the GA, a new generation will be produced by crossover, mutation, and selection. To evolve good individuals, better individuals must be selected from the parents' population to form the individuals of the next generation. We use tournament selection, which mimics natural creatures' selection in which the

individuals compete. The better the fitness of an individual, the greater the probability of being reserved preserved and thereby being reproduced after selection.

Next, two chromosomes are randomly selected and arranged according to their genes in a two-point crossover mechanism, which is to choose two random points on the individual chromosomes and exchange the genetic material at these points as shown in Figure 11. Also, the program will randomly generate a mutation probability value during the process. If this value is lower than the mutation rate, which is set at 0.1 in our research, the chromosome will mutate to prevent premature convergence to the local optimal solution. After crossover and mutation, the new chromosomes are generated. We repeat selecting better fitness from new chromosomes and its parents until all chromosomes are compared. Thus, the total chromosomes are still 50 (population size).

Finally, the process of selection, crossover, and mutation is repeated until the number of generations reaches 1000 (termination condition), and the optimal solution at this point is obtained.

The overall procedure is shown in Figure12.

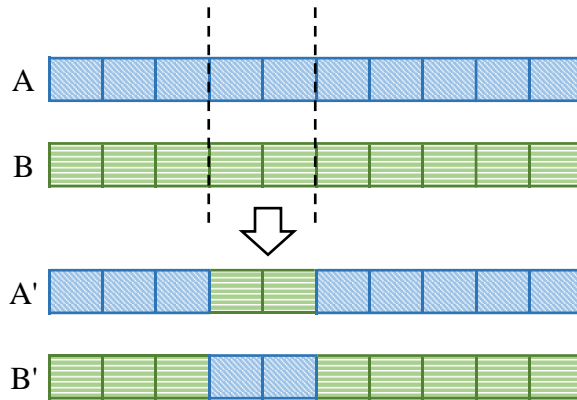

Figure 11 Two-point crossover mechanism

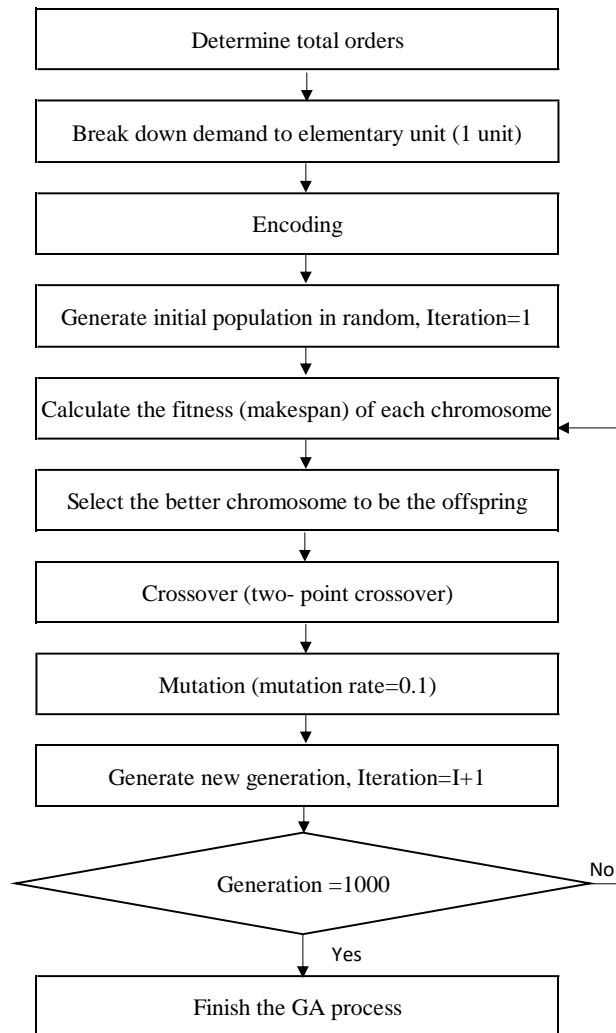

Figure 12 Flow chart of genetic algorithm procedure

Chapter 4. Model Demonstration and Numerical Analysis

This chapter illustrates the application of the model that was formulated in Chapter 3. In Chapter 2.3, we refer to two concepts of production models: BTO and CTO which are used in paint production. Therefore, the purpose of this study is to develop two models to determine the batch size and sequence in each case to minimize the makespan considering the set-up time. Also, various problems are tested using the proposed MILP models.

The machine capacity setting for model A is a three-stage flow shop: five identical parallel machines in stage 1 and stage 2 with a capacity of 50 units; one machine is operated in stage 3 with a capacity of 100 units. There is a four-stage flow shop in model B: five identical parallel machines in stage 1 to stage 3 with 150 units, 50 units, and 50 units for each machine capacity, respectively; one capacitated machine is operated at stage 4 with a capacity of 100 units (Table 3).

Having many product types leads to complicated set up and decreased efficiency, so we mainly discuss at most three product types namely, C, S, and I, and ten colors for a production line in our research. However, the amount of the production line depends on each company's situation. The distribution of the average demand for each product is randomly generated using a normal distribution. Because of the commercial

confidentiality, real demand and production data was not unavailable. We therefore simulated data for the set-up time and processing time for each product in each stage. We consider that set-up time is affected by the composition and product color. For example, it takes less time if product change for bright to dark, or if the composition of the product is similar. The information of set-up time and processing time, as well as the ratio of primary color for each product, are shown in the Appendix section of this thesis.

Table 3 Setting of machines

	Machine capacity		Number of parallel machines	
	Model A	Model B	Model A	Model B
Stage 1	50 units	150 units	5	5
Stage 2	50 units	50 units	5	5
Stage 3	100 units	50 units	1	5
Stage 4	-	100 units	-	1

4.1 Model demonstration

The problem instances are coded in Matlab and solved using Genetic Algorithms (GA) with double-point crossover, the mutation rate of 0.1, and the number of iterations of 1000 times. We ran each problem five times and selected the minimal one to be the optimal value. As the instance in chapter 3, all demand is divided into 10 batches for model A, and 8 batches for model B. Table 4 and Table 5 are the information of optimal results, including batch size, batch sequence, and the machine number used in each stage, except the filter stage. The process of fitness solution for the two models solved

using GA is shown in Figure 13 and Figure 15. Figure 14 and Figure 16 are the detailed processes for the two models. Finally, the optimal objective value (makespan) of this sample instance for the two models are 62.2 mins and 92.3 mins, respectively.

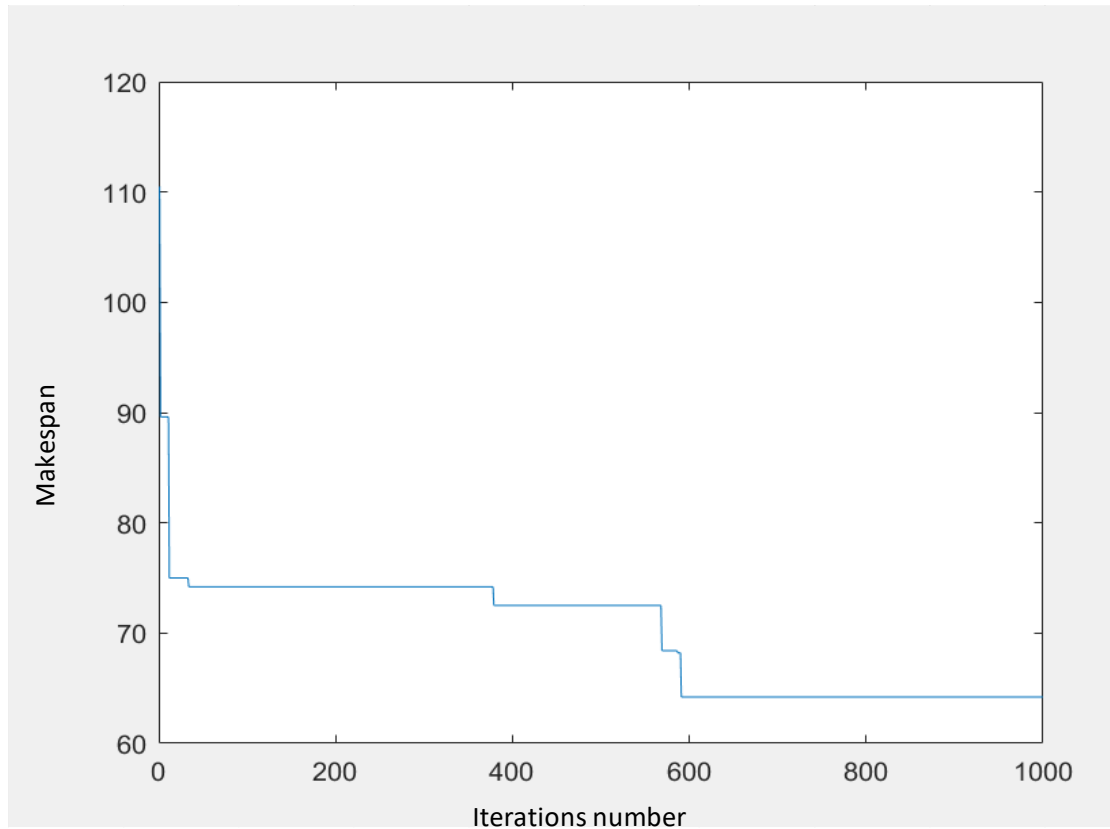

Figure 13 Makespan diagram of instance for model A

Table 4 Optimal result of model A

Batch	1	2	3	4	5	6	7	8	9	10
Product	Orange S	purple I	pink C	purple I	orange S	Pink C	purple I	orange S	pink C	orange S
Size	7	2	1	2	5	7	1	1	2	2
Machine number in stage 1	1	2	3	4	5	3	2	4	2	5
Machine number in stage 2	1	2	1	3	4	4	2	4	1	5

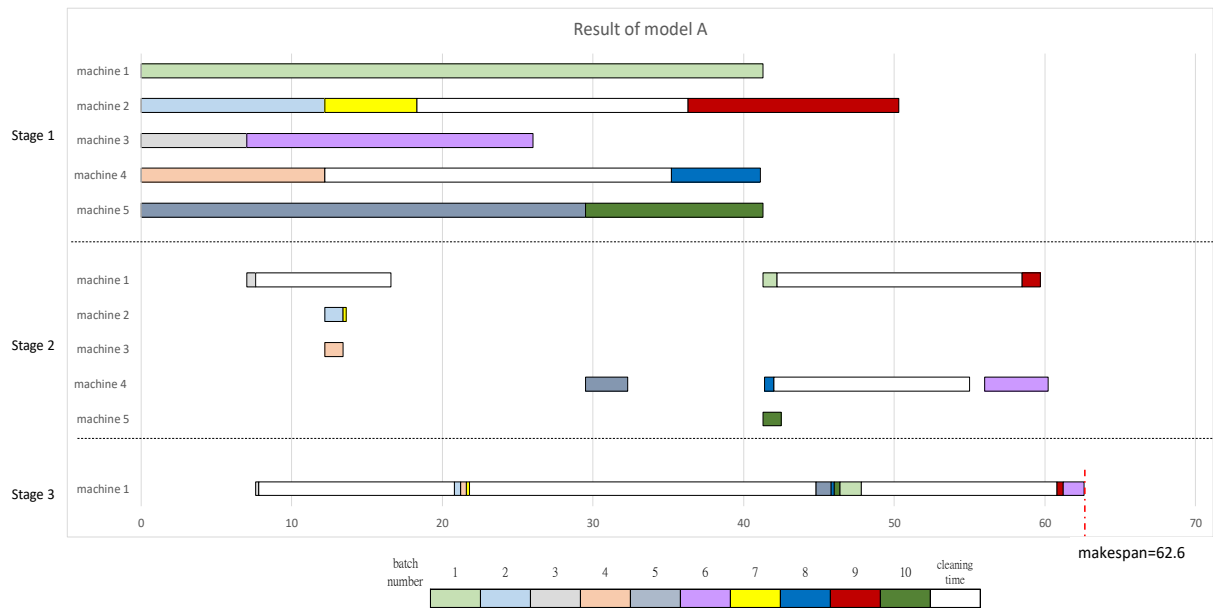

Figure 14 Gantt chart for model A

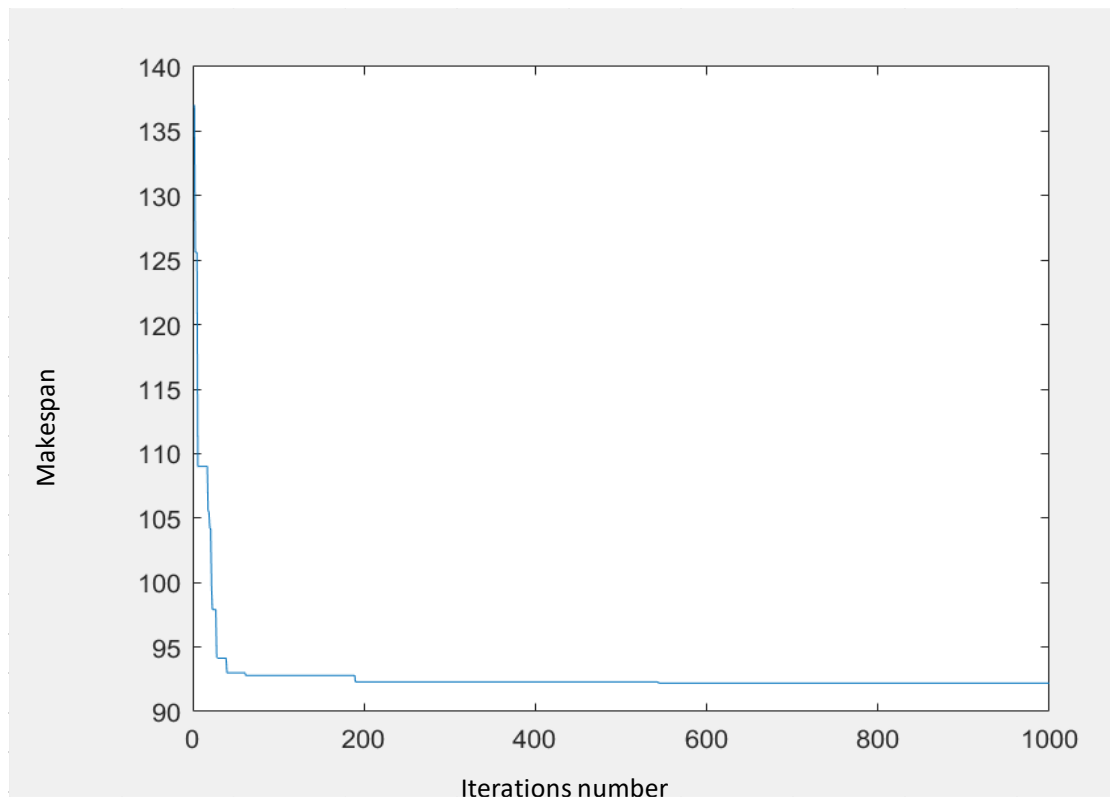

Figure 15 Makespan diagram of instance for model B

Table 5 Optimal result of model B

Batch	1	2	3	4	5	6	7	8
Product	orange S	purple I	pink C	orange S	pink C	orange S	Pink C	orange S
Size	1	5	6	9	3	2	1	3
Machine number in stage 1	1,2	1,2	1,4	1,2	1,4	1,2	1,4	1,2
Machine number in stage 2	1	2	3	1	3	4	3	1
Machine number in stage 3	1	2	3	1	3	4	3	1

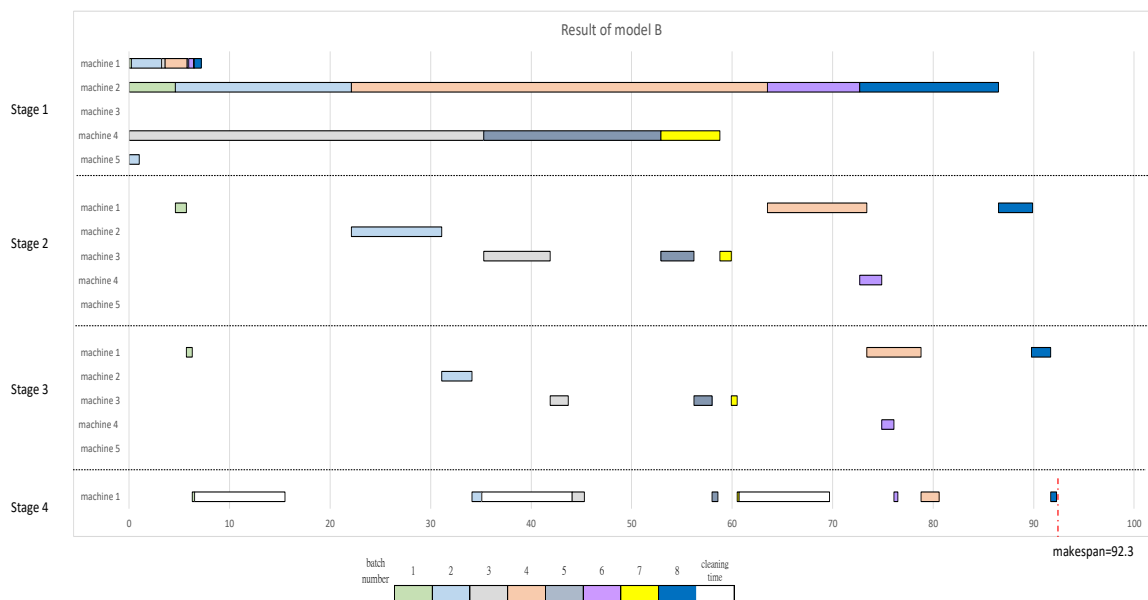

Figure 16 Gantt chart for model B

4.2 Numerical Analysis

We discuss the impact of different set-up time, average demand, number of colors, and number of product types on makespan for two models in this section.

4.2.1 Impact of set-up time on makespan

Five instances are generated to analyze the impact of different set-up time. To test the model sensitivity as part of the analysis, we compare the performances of the two models when the set-up times increased by two to three times with the environment of one product type, five different colors, and average demand of ten units for each product type and color combination. The information for five instances is shown in Table 6.

Figure 17 shows that model A has a better performance when the multiplier of the set-up time is between one and two. As the set-up time increases, the makespan gap between the two models decreases especially up to 2.5 times the set-up time. Unlike model A, a delay in the production of a primary color in model B causes a delay in the processing of all batches that require the primary color. This poses a weakness for model B particularly in stage two. However, because of the dedicated containers, model B is not significantly affected by an increase of set-up time in the first stage. The idle time for model B also reduces as the set-up time increases as shown in Figure 18. On the other hand, an increase in set-up times significantly impacts the all stages of model A. Once the set-up time increases, the makespan increases accordingly and the idle time of each stage remains unchangeable as shown in Figure 19.

While overall model A performs better than B, model A is more sensitive to an increase in set-up times as shown by the steeper piece-wise slopes of model A in Figure

17 than model B. This sensitivity worsens as the set-up time multiplier increases till 2.5.

It is suspected that since model A processes are continuous, without delays such as explained in model B earlier, when the set-up times increase the makespan is markedly increased. In addition, the makespan of model B is less than that of model A when the multiplier of set-up time is three, and we can forecast that the makespan gap will widen if the multiplier is increased further. This sudden change at the 2.5 multiplier mark, where model A begins to exhibit an increase in the makespan than model B should be further examines, which we propose for further research.

Table 6 Setting for analyzing the impact of the set-up time

Instance	Multiplier of set-up time	Number of product types	Number of colors	Average demand for each product
1	1	1	5	10
2	1.5	1	5	10
3	2	1	5	10
4	2.5	1	5	10
5	3	1	5	10

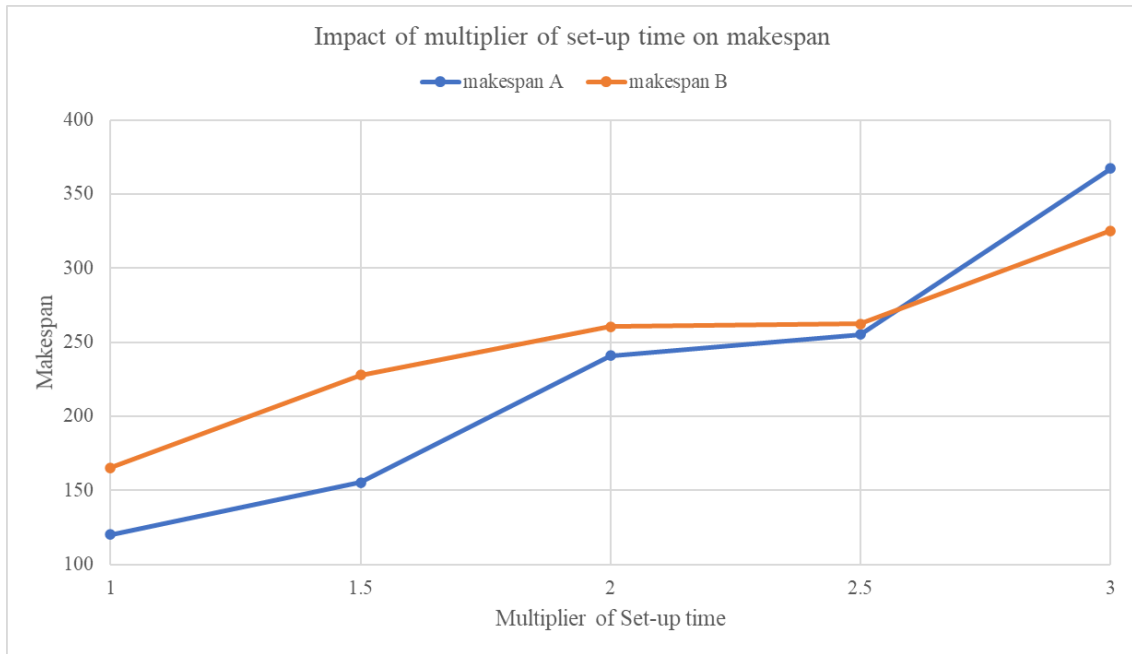

Figure 17 Makespan under different set-up times

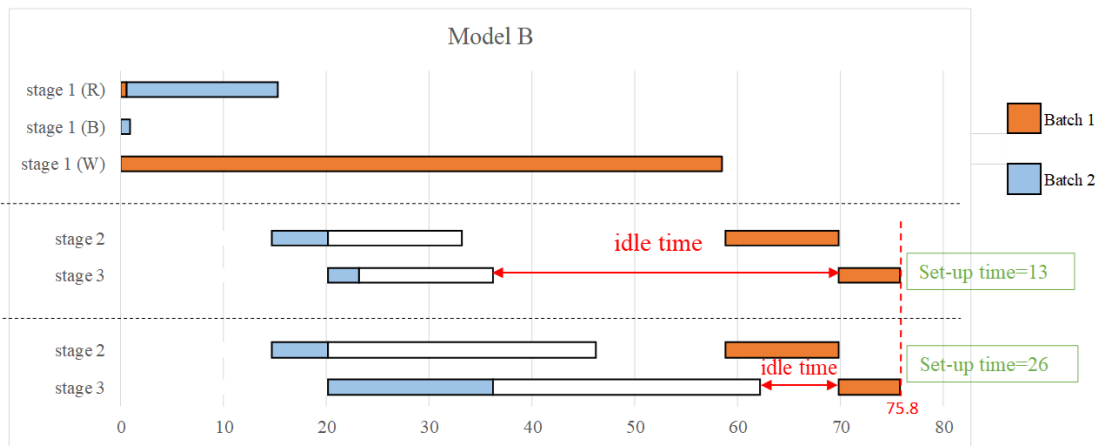

Figure 18 Impact of set-up time on idle time for model B

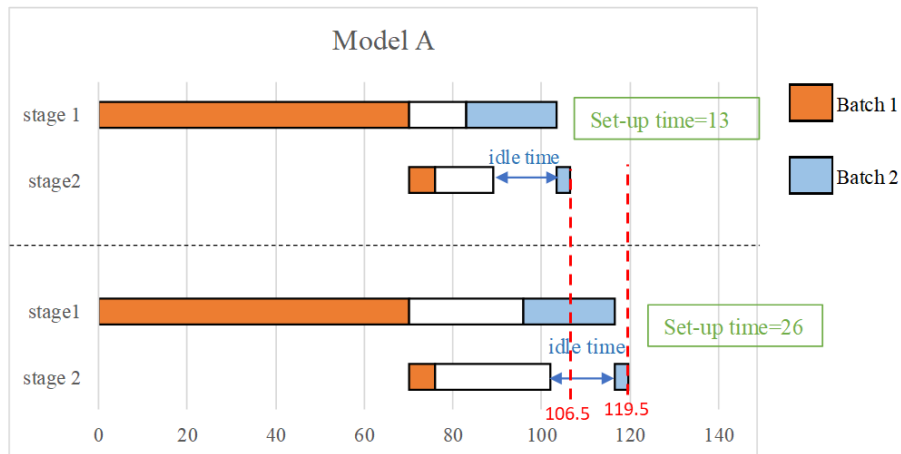

Figure 19 Impact of set-up time on idle time for model A

4.2.2 Impact of the average demand on the makespan

To analyze the impact of the average demand, we test the average demand of 10 units to 100 units with one set-up time, one product type, and five different colors (Table 7). The results are shown in Figure 20. We can see that there is no change on the model decision when the average demand is less than 40 units. However, in comparison to the difference in makespan between A and B when the average demand is 50 units (52.9 mins), the difference in makespan when the average demand is 100 units increases almost 6-fold (363 mins). It indicates that a higher average demand drives the solution to benefit model B. Potentially the benefit toward model B at increased demands stems from the fact that model B offers the advantage of parallel production of primary colors (at shorter times) as opposed to model A which will require the processing of the required final color.

In conclusion, when the average demand is small, the difference between the two

models is not significant. At this time, the difference in the investment costs of the two models can be used as the basis for evaluation. Decision-makers can choose the most suitable production environment based on the current situation and foreseeable future growth.

Table 7 Setting for analyzing the impact of average demand

Instance	Multiplier of set-up time	Number of product types	Number of colors	Average demand
1	1	1	5	10
2	1	1	5	20
3	1	1	5	30
4	1	1	5	40
5	1	1	5	50
6	1	1	5	60
7	1	1	5	70
8	1	1	5	80
9	1	1	5	90
10	1	1	5	100

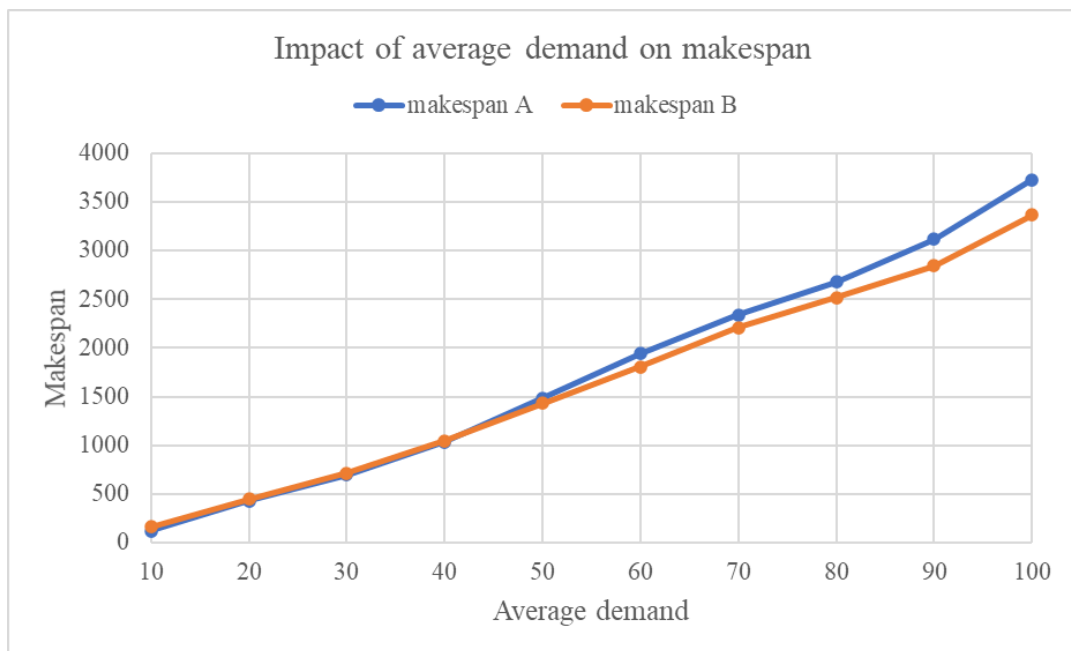

Figure 20 Makespan under different average demand

4.2.3 Impact of the number of products on makespan

We define the number of products as the count of the product types and colors mix, and analyze the impact of these two factors in this section. First, we analyze the impact of the number of colors on the makespan. We use one set-up time, one product type, and an average demand of ten units, with two, four, six, eight, ten, and fifteen colors are set for six instances (Table 8). Results are shown in Figure 21.

From Figure 21, we can see that the makespan of model A is less than that of model B when the number of colors is less than ten. However, when the number of colors increases beyond ten, model B can simply combine diverse products by the limited primary colors, this once more taking advantage of parallel processing of primary colors in stage one. Although the optimal solution (model A versus model B) turns around after eight colors, there is no significant difference between the two models when the number of colors is less than ten. To determine the impact of a large number of colors on the makespan, we also tested fifteen colors. The result shows that when the number of colors is fifteen, the makespan gap between the two models is 225.2 mins, which is obviously larger than the other instances. Therefore, we infer that the makespan gap grows as the number of colors increases. In summary, model A performs better in cases of simple colors. As the number of colors increases, the performance of model B improves, making it appear to be the better choice, and the

two models will have a larger makespan gap.

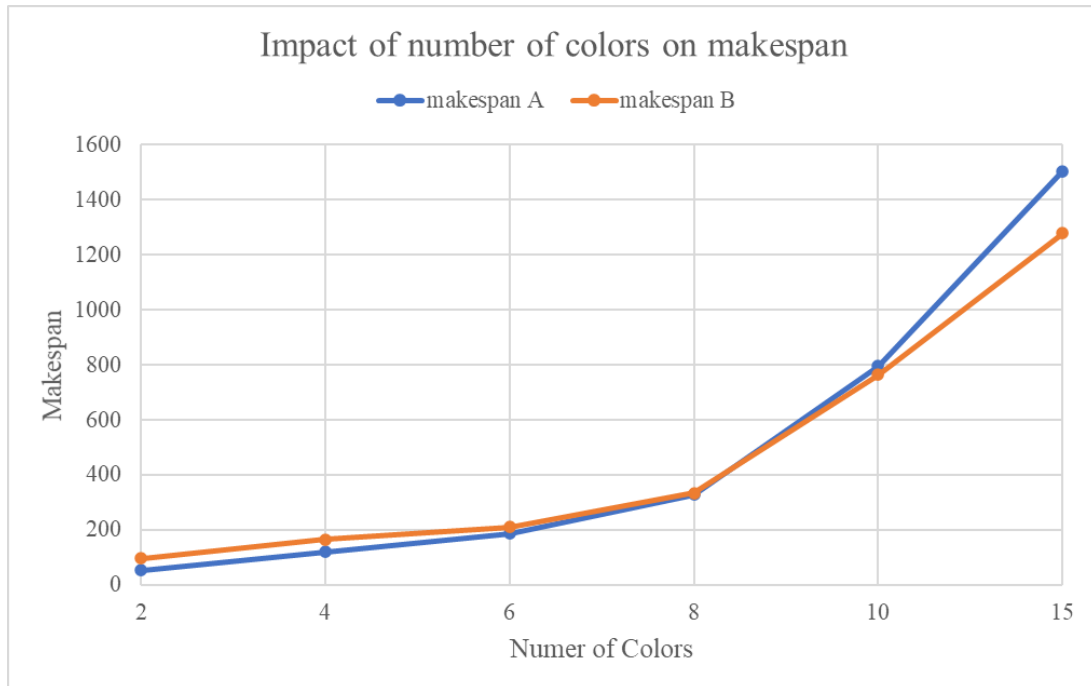

Figure 21 Makespan under different number of colors

Nevertheless, the growth in the number of colors means an increase in total demand, which is defined as the multiplication of the number of products and the average demand in our research. We thus compared the difference between average demand and number of colors under the same total demand. Figure 22 shows that the makespan of the number of colors is always increasing faster than that of the average demand. When the multiplier of total demand is five, the makespan gap for the two models is 609 mins and 493 mins, respectively. This indicates that the number of colors has a greater influence than the average demand and is more influential for model A.

Table 8 Setting for analyzing the impact of number of colors

Instance	Multiplier of set-up time	Number of product types	Number of colors	Average demand	Average demand	Total demand
1	1	1	2	2	10	20
2	1	1	4	4	10	40
3	1	1	6	6	10	60
4	1	1	8	8	10	80
5	1	1	10	10	10	100
6	1	1	15	15	10	150

Table 9 Setting for analyzing the impact of number of product types

Instance	Multiplier of set-up time	Number of product types	Number of colors	Products	Average demand	Total demand
1	1	1	5	5	10	50
2	1	2	5	10	10	100
3	1	3	5	15	10	150

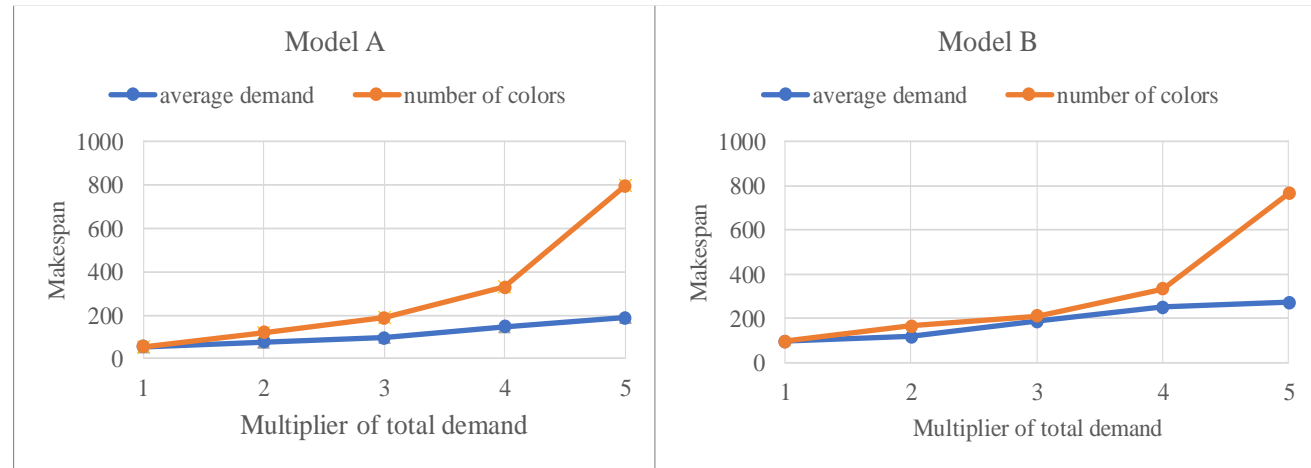

Multiplier of total demand		1	2	3	4	5
Average demand	Multiplier of set-up time	1	1	1	1	1
	Number of product types	1	1	1	1	1
	Number of colors	2	2	2	2	2
	Average demand	10	20	30	40	50
Number of colors	Multiplier of set-up time	1	1	1	1	1
	Number of product types	1	1	1	1	1
	Number of colors	2	4	6	8	10
	Average demand	10	10	10	10	10

1	2	3	4	5
1	1	1	1	1
1	1	1	1	1
2	2	2	2	2
10	20	30	40	50
1	1	1	1	1
1	1	1	1	1
2	4	6	8	10
10	10	10	10	10

Figure 22 Comparison of average demand and colors for model A and model B

Second, we analyze the impact of the number of product types on makespan. One set-up time, five colors, and an average demand of ten units, with one to three product types are set for three instances (Table 9). The results are shown in Figure 23. In these instances, model A completes all demand 45 mins earlier than model B when there is only one type of product. However, the makespan of the two models is closer as the number of types increases, and model B even saves one hour on makespan when there are three types of products. Since Model B is limited by the primary colors in the first stage, it can schedule batches more efficiently of the same color but different types together to reduce the set-up time. Consider the instance of four products: pink C, pink S, pink I, and blue-gray I. All four products need white, which requires the longest unit processing time of all the primary colors. Batches will be assigned to the second stage in sequence because batches can be transferred until the white primary color is finished. Therefore, if products with the same color but different types are arranged together in the first stage, it will be more conducive for reducing set-up time in the subsequent stages. Conversely, since different colors and varying batch sizes result in different completion times for model A in the first stage, the batches will not be transferred to the second stage based on the batch sequence. Thus, even if products with the same color but different types are scheduled together in the first stage, they may not be able to be assigned to the same machine in the next stage, resulting in increased set-up time.

In the instance where the number of product types is three, the set-up times of model A is 281, and model B is 263.

In the case where the makespan of the two models is not much different, i.e the case of two product types, other product characteristics, such as the number of colors and the average demand, can be considered when evaluating which model can bring greater benefits. The following is an analysis of these factors.

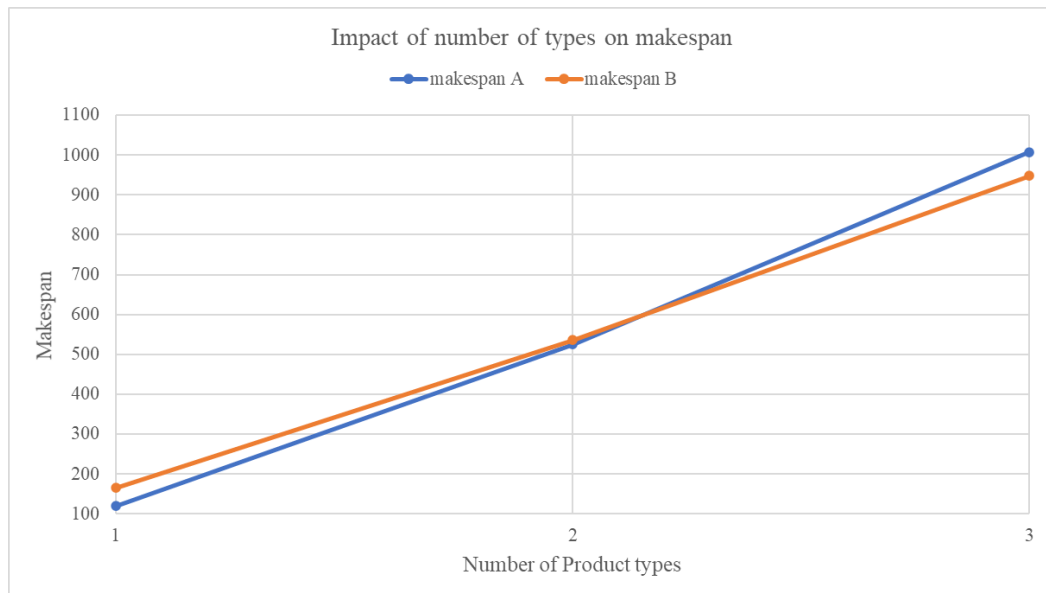
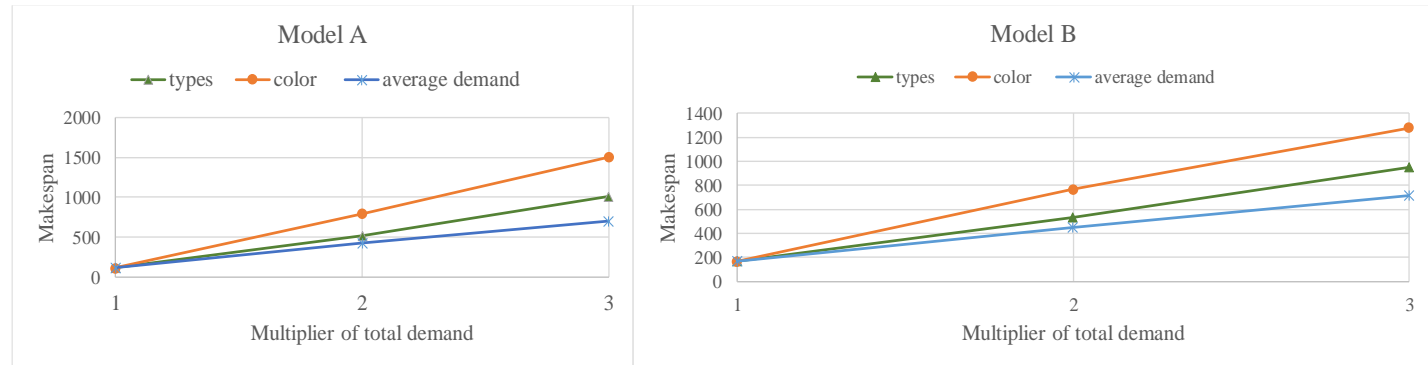

Figure 23 Makespan under different number of product types

Figure 24 shows the impact of the different number of product types, number of colors, and average demand on makespan under the same total demand. We find that for model A the makespan of the number of colors increases 1.5 times faster than that of the number of product types, and also more than twice than that of the average demand. Further, for model B, the makespan of the number of colors increases 1.35 times faster than that of the number of product types, and also 1.8 times more than the

average demand. Therefore, we know that the number of colors have a greater effect on the makespan, followed by the number of product types, and finally by the average demand. Furthermore, the impact of the number of colors and product types on model A is greater than on model B.

In summary, model A appears more suitable for simple product types, meaning for low mix, high volume scenarios, while model B is the better choice when product types are complex i.e. high mix, low or high volume.



Multiplier of total demand		1	2	3
Types	Multiplier of set-up time	1	1	1
	Number of product types	1	2	3
	Number of colors	5	5	5
	Average demand	10	10	10
Colors	Multiplier of set-up time	1	1	1
	Number of product types	1	1	1
	Number of colors	5	10	15
	Average demand	10	10	10
Average demand	Multiplier of set-up time	1	1	1
	Number of product types	1	1	1
	Number of colors	5	5	5
	Average demand	10	20	30

Multiplier of total demand		1	2	3
Types	Multiplier of set-up time	1	1	1
	Number of product types	1	2	3
	Number of colors	5	5	5
	Average demand	10	10	10
Colors	Multiplier of set-up time	1	1	1
	Number of product types	1	1	1
	Number of colors	5	10	15
	Average demand	10	10	10
Average demand	Multiplier of set-up time	1	1	1
	Number of product types	1	1	1
	Number of colors	5	5	5
	Average demand	10	20	30

Figure 24 Comparison of average demand and colors for model A and model B

Chapter 5. Conclusion and Future Work

5.1 Conclusion

This study presents two mathematical production models for the paint manufacturing process namely, build-to-order (BTO) and the variation of a configuration-to-order (CTO), called group production. The sole difference between these two models is that model B calculates the requirements of each batch for its primary colors (white, black, red, blue, and yellow paints), and sequentially pre-mixes, disperses, and grinds the five primary colors in the first stage. The purpose of this research is to develop a mathematical approach to minimize the makespan considering both process models. Two MILP models are solved using genetic algorithms to determine the optimal batch size and batch sequence. We also analyze the influence of different numbers of colors, numbers of product types, set-up time multipliers, and average demand on makespan as a reference for decision-makers in making decisions.

Based on the results for the option of the small average demand of this research, it is pointed out that the change of product diversity, set-up time multiplier, and average demand will affect the choice of the optimal model. The results of the research that found when the number of colors and paint types are considered, model A performs better under simple product diversity. Which means that model A is suitable for paint

companies that exhibit a low mix, high or low volume, while model B is most suitable in scenarios with high mix, low or high volume. On the other hand, model A has no obvious advantage considering the average demand. Although the performance of model A is compared to model B in the case of small average demand is not visible, model B can complete total demand faster in the case of large average demand. Therefore, we infer that model A will offer a better production environment when the company is a start-up company or has a small production scale and simple products, such as a firm that specializes in urgent orders or mass- customized products.

By contrast, model B combines a variety of products with primary colors easily. As the average demand and product diversity increase, model B becomes a better choice. Further, model B is relatively less sensitive to the increase in set-up time. It can be inferred that model B will be the better choice if mass production of a variety of products is required or there is a big difference between products, which requires a long setup time. However, several important things should be taken into account. First, it is easy to build a great quantity inventory of primary colors. Second, the design of the plant will be more complicated because of the increase in stages. Finally, the high requirements for machines and spaces lead to higher fixed asset costs.

The major contribution of this study is to analyze the grouping effectiveness (schedule) and find the applicable environments for the CTO and BTO strategies.

Unlike other research, this study also considers group production which is based on the concept of CTO. CTO is commonly used in many industries, such as the computer industry and the semiconductor industry, so this research is looking at the feasibility and applicable environments of using the CTO concept in the paint industry. Furthermore, the analysis of this research is useful for manufacturers in determining their production environments based on their product features and the prospects or plant expansion and reorganization.

5.2 Research limitations and suggestions for future work

1. We visited one paint factory in Taiwan and one in the United States, but sufficient data was not available because of company data confidentiality. Secondly, due to the Covid-19 pandemic, continued talks for data acquisition and plant visits were greatly hampered. Therefore, it is recommended that future research in this direction will require collaboration with paint factories to obtain more relevant information on the manufacturing process and for validation of the model results.
2. Many values in this study are derived through inferences and assumptions, such as processing time, set-up time, and demand. We suggest visiting experts in this fields, such as paint factories, paint retailers, and paint developers, to obtain more representative data and information in future research.
3. This study only analyzes the makespan but does not take cost into account. It is

suggested that future research consider the completion time and cost simultaneously to make the analysis more comprehensive. In addition, the results of this research brought to light the need to address the potential trade-offs between makespan and process costs, particularly by adding a penalty in the objective function, to account for the number of parallel machines being run at a given process stage, as well as a cost for machine idle time.

4. Compared with the actual problems solved in practice, the demand for problems in experimental research is small. Thus, effective heuristics to solve large-size, more realistic-scale industrial problems is a necessary extension to this work.

Bibliography

1. Adonyi, R., Biros, G., Holczinger, & T., Friedler, F. (2008). Effective scheduling of a large-scale paint production system. *Journal of Cleaner Production*, 16(2), 10.1016/j.jclepro.2006.08.021
2. Admin. (2019). Configure to Order. Retrieved from <https://www.orderhive.com/knowledge-center/configure-to-order> (12/07/2020).
3. Azzi, A., Faccio, M., Persona, A. & Sgarbossa, F. (2012). Lot splitting scheduling procedure for makespan reduction and machine capacity increase in a hybrid flow shop with batch production. *The International Journal of Advanced Manufacturing Technology*, 59, 775–786, 775–786. <https://doi.org/10.1007/s00170-011-3525-x>.
4. Baumannet, P., & Trautmann, N. (2013). A continuous-time MILP model for short-term scheduling of make-and-pack production processes. *International Journal of Production Research*, 51(6), 1707-1727. 10.1080/00207543.2012.694489.
5. Benjaafar, S., & Elhafsi, M. (2006). Production and inventory control of a single product assemble-to-order system with multiple customer classes. *Management Science*, 52(12):1896-1912. 10.1287/mnsc.1060.0588.
6. Božek, A., Werner, F. (2017). Flexible job shop scheduling with lot streaming and subplot size optimization. *International Journal of Production Research*, 56(8). 10.1080/00207543.2017.1346322.
7. Chen, Y, J., Zhang, M., & Tseng, M, M. (2004). An integrated process planning and production scheduling framework for mass customization. *Journal for Manufacturing Science and Production*, 6(1-2). 10.1515/IJMSP.2004.6.1-2.89.
8. Chuang, C, S. (2004). Experiences with MILP- and LR-based approaches for unit ommitment.
9. Diplom. (2019). Paints Industry: Raw materials & unit operations & equipment & manufacturing & quality tests. 10.13140/RG.2.2.22793.60007.
10. Dursun, D., & Sengul, F. (2006). Waste minimization study in a solvent-based paint manufacturing plant. *Resources, Conservation and Recycling*, 47, 316–331. 10.1016/j.resconrec.2005.12.004.
11. Ebrahimia, M., Moghaddam, R.T., & Jolaib, F. (2018). Bi-objective build-to-order supply chain problem with customer utility. *International Journal of Engineering*, 31(7), 1066-1073. 10.5829/ije.2018.31.07a.09
12. Floudas, C, A., & Lin, X, N. (2005). Mixed Integer Linear Programming in process scheduling: modeling, algorithms, and applications. *Annals of Operations Research*, 139(1),131-162. 10.1007/s10479-005-3446-x.

13. Garside, M (2020). PPG Industries' revenue from 2009 to 2019. Retrieved from <https://www.statista.com/statistics/218763/net-sales-of-ppg-industries/> (August 15, 2020).
14. Holweg, M., & Pil, F, K. (2004). *The second century: reconnecting customer and value chain through build-to-order; moving beyond mass and lean production in the auto industry*, MIT Press.
15. Olson, J, R., & Schniederjans, M, J. (2000). A heuristic scheduling system for ceramic industrial coatings. *Interfaces*, 30(5), 16-22. 10.1287/inte.30.5.16.11635.
16. Kurz, M, E., Askin, R, G. (2004). Scheduling flexible flow lines with sequence dependent setup times. *European Journal of Operational Research*, 159 (1), 16, 66-82. 10.1016/S0377-2217(03)00401-6.
17. Lazarevic, D., Cosic, I., Lazarevic, M., Rikalovic, A., & Sremcevic, N. (2014). Application of group tools in production of printed and laminated cardboard packaging for total in-process time reduction. *Procedia Engineering*, 69, 1381-1387. 10.1016/j.proeng.2014.03.132.
18. Manufacturing of Paint. Batch mixing of paint. Retrieved from <https://fluidan.com/manufacturing-of-paint/> (November 4, 2020).
19. Orcun, S., Discioglu, A., Kuban Altinel, I., & Hortacsu, O. (1997). Scheduling of batch processes: an industrial application in paint industry. *Computers and Chemical Engineering*, 1997;21:673e8.
20. Orçun, S., Altinel, K., & Hortaçsu, o. (2001). General continuous time models for production planning and scheduling of batch processing plants, Mixed Integer Linear Program formulations and computational issues. *Computers and Chemical Engineering*, 25(2), 371–389, 10.1016/S0098-1354(00)00663-3.
21. Ormeci, M. (2006). Inventory control in a build-to-order environment.
22. Parry, G. C. and Graves, A. P. (2008). *Build to order: the road to the 5-day car*. springer.
23. Pilcher, G. R & Rezai, M (2018). The global paint and coatings industry. Retrieved from https://chemquest.com/wp-content/uploads/2018/10/ECJ_10_2018_Market_Report_ChemQuest_Pilcher.pdf (August 15, 2020).
24. Pilcher, G. R (2018). Nine Years Following the Great Recession: The state of the U.S. paint and coatings industry. Retrieved from <https://www.paint.org/coatingstech-magazine/articles/nine-years-following-great-recession-state-u-s-paint-coatings-industry/> (August 20, 2020).
25. Pilcher, G, R. (2018). The demand for coatings raw materials to 2022. Retrieved from <https://www.paint.org/coatingstech-magazine/articles/demand-coatings-raw-materials-to-2022/> (November 27, 2020).

26. Schultmann, F., & Fröhling, M., & Rentz, O. (2006). Fuzzy approach for production planning and detailed scheduling in paints manufacturing. *International Journal of Production Research*, 21, s673-s678.
27. See-toh, Y, C. (2007). Paints Supply Chain Optimisation.
28. Shahvari, O., & Logendran, R. (2018). A comparison of two stage-based hybrid algorithms for a batch scheduling problem in hybrid flow shop with learning effect. *International Journal of Production Economics*, 195, 227-248. 10.1016/j.ijpe.2017.10.015.
29. Swamidass, P, M. (2000). Encyclopedia of Production and Manufacturing Management. Springer, Boston, MA. 10.1007/1-4020-0612-8.
30. Tao, H., Xinquan, T. (2010). The Application of Group Technology in Production of High-/Low-Voltage Electrics. *International Conference on E-Product E-Service and E-Entertainment*. 10.1109/ICEEE.2010.5661526.
31. Wang, S. (2015). Integrated batching and lot streaming with variable sublots and sequence-dependent setups in a two-stage hybrid flow shop.
32. Wang, S., Kurz, M., Mason, S, J., & Rashidi, E. (2019). Two-stage hybrid flow shop batching and lot streaming with variable sublots and sequence dependent setups. *International Journal of Production Research*, 57(22), 10.1080/00207543.2019.1571251.
33. Wemmerlöv, U. (1984). Assemble-to-order manufacturing: implications for materials management. *Journal of operations management*, 4(4), 347-368. 10.1016/0272-6963(84)90021-4.
34. What is paint and how is it made? Paint manufacturing process. Retrieved from <https://www.resene.co.nz/whatispaint.htm> (November 4, 2020).
35. Yu, C., Ji, Y., Qi, G., Gu, X., & Tao, L. (2015). Group-based production scheduling for make-to-order production. *Journal of Intelligent Manufacturing*, 26, 585–600. 10.1007/s10845-013-0817-z.
36. 夢梵. (2019). 2019-2025 年前景預測之塗料行業生產製造及技術. Retrieved from <https://kknews.cc/finance/j25r636.html?fbclid=IwAR1hvllbTFD8pv3QvpJy6ZZovyXYEylKY4ViaXFnr-xzFnlVpEA6x413A> (11/27/2020).

Appendix

Set-up time for products in the pre-mix, grinding and dispersing, and toning stage (mins/ per batch)

	Pink	Orange	Brown	Iron red	Purple	Grey blue	Cream -colored	Camel	Grey green	Pea green
Pink	0	9	13	13	13	23	9	13	23	18
Orange	13	0	9	9	18	23	9	9	18	23
Brown	23	23	0	9	13	18	23	9	13	18
Iron red	23	23	9	0	13	13	23	13	13	18
Purple	18	18	13	9	0	9	23	18	18	23
Grey blue	23	23	18	18	23	0	23	23	13	23
Cream-colored	13	9	9	9	9	13	0	9	13	13
Camel	13	13	9	9	13	13	13	0	13	13
Grey green	16	13	13	13	13	9	23	9	0	9
Pea green	18	13	13	9	13	13	23	13	18	0

Set-up time for products in the blending and filter stage (mins/ per batch)

	pink (C)	pink (S)	pink (I)	orange (C)	orange (S)	orange (I)	brown (C)	brown (S)	brown (I)	iron red (C)	iron red (S)	iron red (I)	purple (C)	purple (S)	purple (I)
pink (C)	0	5	5	9	9	9	13	13	13	13	13	13	13	13	13
pink (S)	5	0	5	9	9	9	13	13	13	13	13	13	13	13	13
pink (I)	5	5	0	9	9	9	13	13	13	13	13	13	13	13	13
orange (C)	13	13	13	0	5	5	9	9	9	9	9	9	18	18	18
orange (S)	13	13	13	5	0	5	9	9	9	9	9	9	18	18	18
orange (I)	13	13	13	5	5	0	9	9	9	9	9	9	18	18	18
brown (C)	23	23	23	23	23	23	0	5	5	9	9	9	13	13	13
brown (S)	23	23	23	23	23	23	5	0	5	9	9	9	13	13	13
brown (I)	23	23	23	23	23	23	5	5	0	9	9	9	13	13	13
iron red (C)	23	23	23	23	23	23	9	9	9	0	5	5	13	13	13
iron red (S)	23	23	23	23	23	23	9	9	9	5	0	5	13	13	13
iron red (I)	23	23	23	23	23	23	9	9	9	5	5	0	13	13	13
purple (C)	18	18	18	18	18	18	13	13	13	9	9	9	0	5	5
purple (S)	18	18	18	18	18	18	13	13	13	9	9	9	5	0	5
purple (I)	18	18	18	18	18	18	13	13	13	9	9	9	5	5	0
grey blue (C)	23	23	23	23	23	23	18	18	18	18	18	18	23	23	23
grey blue (S)	23	23	23	23	23	23	18	18	18	18	18	18	23	23	23
grey blue (I)	23	23	23	23	23	23	18	18	18	18	18	18	23	23	23
cream-colored (C)	13	13	13	9	9	9	9	9	9	9	9	9	9	9	9
cream-colored (S)	13	13	13	9	9	9	9	9	9	9	9	9	9	9	9
cream-colored (I)	13	13	13	9	9	9	9	9	9	9	9	9	9	9	9
camel (C)	13	13	13	13	13	13	9	9	9	9	9	9	13	13	13
camel (S)	13	13	13	13	13	13	9	9	9	9	9	9	13	13	13
camel (I)	13	13	13	13	13	13	9	9	9	9	9	9	13	13	13
grey green (C)	16	16	16	13	13	13	13	13	13	13	13	13	13	13	13
grey green (S)	16	16	16	13	13	13	13	13	13	13	13	13	13	13	13
grey green (I)	16	16	16	13	13	13	13	13	13	13	13	13	13	13	13
pea green (C)	18	18	18	13	13	13	13	13	13	9	9	9	13	13	13
pea green (S)	18	18	18	13	13	13	13	13	13	9	9	9	13	13	13
pea green (I)	18	18	18	13	13	13	13	13	13	9	9	9	13	13	13

Set-up time for products in the blending and filter stage (mins/ per batch)

	grey blue (C)	grey blue (S)	grey blue (I)	cream- colore d (C)	cream- colore d (S)	cream- colore d (I)	camel (C)	camel (S)	camel (I)	grey green (C)	grey green (S)	grey green (I)	pea green (C)	pea green (S)	pea green (I)
pink (C)	23	23	23	9	9	9	13	13	13	23	23	23	18	18	18
pink (S)	23	23	23	9	9	9	13	13	13	23	23	23	18	18	18
pink (I)	23	23	23	9	9	9	13	13	13	23	23	23	18	18	18
orange (C)	23	23	23	9	9	9	9	9	9	18	18	18	23	23	23
orange (S)	23	23	23	9	9	9	9	9	9	18	18	18	23	23	23
orange (I)	23	23	23	9	9	9	9	9	9	18	18	18	23	23	23
brown (C)	18	18	18	23	23	23	9	9	9	13	13	13	18	18	18
brown (S)	18	18	18	23	23	23	9	9	9	13	13	13	18	18	18
brown (I)	18	18	18	23	23	23	9	9	9	13	13	13	18	18	18
iron red (C)	13	13	13	23	23	23	13	13	13	13	13	13	18	18	18
iron red (S)	13	13	13	23	23	23	13	13	13	13	13	13	18	18	18
iron red (I)	13	13	13	23	23	23	13	13	13	13	13	13	18	18	18
purple (C)	9	9	9	23	23	23	18	18	18	18	18	18	23	23	23
purple (S)	9	9	9	23	23	23	18	18	18	18	18	18	23	23	23
purple (I)	9	9	9	23	23	23	18	18	18	18	18	18	23	23	23
grey blue (C)	0	5	5	23	23	23	23	23	23	13	13	13	23	23	23
grey blue (S)	5	0	5	23	23	23	23	23	23	13	13	13	23	23	23
grey blue (I)	5	5	0	23	23	23	23	23	23	13	13	13	23	23	23
cream-colored (C)	13	13	13	0	5	5	9	9	9	13	13	13	13	13	13
cream-colored (S)	13	13	13	5	0	5	9	9	9	13	13	13	13	13	13
cream-colored (I)	13	13	13	5	5	0	9	9	9	13	13	13	13	13	13
camel (C)	13	13	13	13	13	13	0	5	5	13	13	13	13	13	13
camel (S)	13	13	13	13	13	13	5	0	5	13	13	13	13	13	13
camel (I)	13	13	13	13	13	13	5	5	0	13	13	13	13	13	13
grey green (C)	9	9	9	23	23	23	9	9	9	0	5	5	9	9	9
grey green (S)	9	9	9	23	23	23	9	9	9	5	0	5	9	9	9
grey green (I)	9	9	9	23	23	23	9	9	9	5	5	0	9	9	9
pea green (C)	13	13	13	23	23	23	13	13	13	18	18	18	0	5	5
pea green (S)	13	13	13	23	23	23	13	13	13	18	18	18	5	0	5
pea green (I)	13	13	13	23	23	23	13	13	13	18	18	18	5	5	0

(continue)

Processing time for model A (mins/ unit)

Stage1		Stage2		Stage 3
Pink	7	Cargo container (C)	0.6	0.2
Orange	5.9	Ship hull (S)	0.6	
Brown	6.1	Industrial structure (I)	0.6	
Iron red	5			
Purple	4.1			
Grey blue	6.9			
Cream-colored	7.7			
Camel	8			
Grey green	8.3			
Pea green	7.6			

Processing time for model B (mins/ unit)

Stage 1		Stage2		Stage 3		Stage 4
Red (R)	3	Pink	1.1	Cargo container (C)	0.6	0.2
Yellow (Y)	5	Orange	1.1	Ship hull (S)	0.6	
Blue (B)	3	Brown	1.8	Industrial structure (I)	0.6	
White (W)	6	Iron red	1.8			
Black (Bl)	2	Purple	1.1			
		Grey blue	1.8			
		Cream-colored	1.8			
		Camel	2.5			
		Grey green	2.5			
		Pea green	1.8			

Ratio of primary color for colors

(Colors)	Primary colors				
	Red	Yellow	Blue	White	Black
Pink	0.02	0	0	0.98	0
Orange	0.08	0.92	0	0	0
Brown	0.2	0.7	0	0	0.1
Iron red	0.73	0.16	0	0	0.11
Purple	0.94	0	0.06	0	0
Grey blue	0	0	0.13	0.73	0.14
Cream-colored	0.01	0.04	0	0.95	0
Camel	0.04	0.21	0	0.7	0.05
Grey green	0	0.05	0.02	0.91	0.02
Pea green	0	0.1	0.03	0.87	0