

A TWO-STAGE MODEL FOR OPTIMAL OPERATION OF MULTI-ENERGY HUB
SYSTEM FOR RESILIENCE ENHANCEMENT AGAINST NATURAL DISASTERS

by
Yanan Zhang

A Thesis Submitted in
Partial Fulfillment of the
Requirements for the Degree of

Master of Science
in Engineering

at
The University of Wisconsin-Milwaukee
May 2019

ABSTRACT

A TWO-STAGE MODEL FOR OPTIMAL OPERATION OF MULTI-ENERGY HUB SYSTEM FOR RESILIENCE ENHANCEMENT AGAINST NATURAL DISASTERS

by
Yanan Zhang

The University of Wisconsin-Milwaukee, 2019
Under the Supervision of Dr. Lingfeng Wang

The climate change leads to more natural disasters which can lead to two results, one is that some generation and transmission infrastructures of energy will endure serious damages, and another is that cities and districts will probably be exposed to potentially large-scale blackouts. The pressures of energy and environment problems have prompted people to reflect on existing energy consumption patterns and begin to study the comprehensive utilization of various types of energy such as electricity, gas and heat. The concept of energy hub (EH) has emerged. It is a key hub within multi-energy network.

A Two-stage model for the operation of multi-energy hub system for resilience enhancement in natural disasters was established in this thesis. The system includes three different energy hub systems, each EH consists of electric transformer, Combined Cooling, Heating and Power (CCHP), Energy Storage System (ESS) and chiller which are responsible for energy conversion and transfer. Each EH is connected to the main electric network and natural gas network. There are also transmission lines and pipelines connected between them for energy communication.

The purpose of this model is to reduce the load shedding as much as possible while ensuring the maximum economic benefits including operation costs and load curtailment punishing fees of both two stages, so that each EH system can make a reasonable energy supply externally and maintain stable operation internally.

When disaster happens, the system will go through two stages, first stage is the one before disaster and second stage is the one when disaster occurs. The choices made by the system will be different at these two stages, including selling and purchasing value from the main network, storing and releasing energy value of ESS, conversion ratio for different energies within EH and the load shedding value of demand side because each stage has different transmission rate and load demand.

Three case studies have been done. YALMIP toolbox of MATLAB has been used to solve these problems. In case study one, the result shows that the total cost of two-stage model reduced by about 25% compared to the separate stage model, and load curtailment, especially electricity, was reduced sharply. In case study two, after load priority setting, load curtailment fee has been reduced obviously by 8.2%, shedding value of significant load has been reduced up to 26.9%. In case study three, the total cost of coordinated 3-EH model has been reduced by 57.59% compared to the model without coordination, and each EH has saved cost by 32.92%, 69.38% and 53.21% respectively. The result shows great advantages of this model, by using the two stage the total cost and load curtailment value reduced significantly for both whole system and each EH.

© Copyright by Yanan Zhang, 2019
All Rights Reserved

TABLE OF CONTENTS

Chapter 1 Introduction of energy network.....	1
1.1 Research background	1
1.1.1 Multiple Energy Systems (MES).....	1
1.1.2 Research status	2
1.1.3 Energy system resiliency.....	5
1.2 Energy hub (EH)	6
1.2.1 Basic concept	6
1.2.2 Basic components of EH.....	7
1.2.3 Energy hub and multi-energy systems.....	8
1.2.4 Benefits of Energy hub	8
1.3 Research outline	10
1.3.1 Problem description	10
1.3.2 Major contributions	12
Chapter 2 Single energy hub model.....	13
2.1 Basic structure	13
2.1.1 CCHP model	15
2.1.2 Chiller model.....	19

2.1.3 Load model.....	20
2.1.4 Energy storage model.....	24
2.2 Scenario design	29
2.3 Problem description	30
2.3.1 Mathematical expression	30
2.3.2 Case studies	33
Chapter 3 Multi-energy hub model	41
3.1 Basic structure	41
3.2 Case study	42
3.2.1 Basic data	42
3.2.2 Mathematical expression	45
3.2.3 Case study results	47
Chapter 4 Conclusion and future work.....	55
4.1 Conclusion.....	55
4.2 Future Work	56
References	57

LIST OF FIGURES

Figure 1-1 Input-output port model for multiple energy system	6
Figure 1-2 Basic architecture of energy internet.....	8
Figure 2-1 Structure of one typical EH system.....	14
Figure 2-2 Electricity load curve of EHA.....	36
Figure 2-3 Price data.....	36
Figure 2-4 Load curtailment fees comparison	40
Figure 2-5 Load curtailment comparison between non-load priority mode and load priority mode.....	42
Figure 3-1 Three-energy hub system structure	43
Figure 3-2 Load curve of EHA	46
Figure 3-3 Load curve of EHB	47
Figure 3-4 Load curve of EHC	47
Figure 3-5 Operate mode that coordinate EHB&EHC, separate EHA	54
Figure 3-6 Operate mode that coordinate EHA&EHC, separate EHB	54
Figure 3-7 Operate mode that coordinate EHA&EHB, separate EHC	55

LIST OF TABLES

Table 2-1 Parameter of EHA.....	34
Table 2-2 Parameter of CCHP	34
Table 2-3 Two-stage optimization mode results/yuan	35
Table 2-4 Separated stage 1 results of normal mode/yuan.....	35
Table 2-5 Separated stage 2 results of normal mode/yuan.....	35
Table 2-6 Load curtailment punishing fee	38
Table 2-7 Electric load curtailment (load without priority)	39
Table 2-8 Electric load curtailment (load with priority)	39
Table 3-1 Parameter of EHA.....	39
Table 3-2 Parameter of EHB	39
Table 3-3 Parameter of EHC	39
Table 3-4 Objective result without coordination.....	39
Table 3-5 Objective result with coordination.....	50
Table 3-6 Objective result when coordinate EHB&EHC, separate EHA	51
Table 3-7 Objective result when coordinate EHA&EHC, separate EHB	52
Table 3-8 Objective result when coordinate EHB&EHC, separate EHC	53

ACKNOWLEDGEMENTS

First of all, I would like to express my gratitude to all those who helped me during the research and writing of this thesis. I greatly acknowledge the mentorship from my supervisor, Dr. Lingfeng Wang, who has given me numerous valuable suggestions in my academic studies. In the preparation of this thesis, he has spent much time listening to each presentation and has provided me with inspiring advice. He has been constantly sending me the literature and materials on related topics, which has given me a lot of inspiration in the research process. Without his patient instructions, insightful comments, and professional guidance, the completion of this thesis would not have been possible.

Second, I also owe a special debt of gratitude to Dr. Li Ma and Dr. Zhaoxi Liu, from whose devoted teaching and enlightening help I have benefited a lot while preparing for the thesis. They often talked to me about models and programming and gave me useful advice. Without their help, I couldn't have finished this thesis.

Third, I would like to thank the committee members, Dr. Jun Zhang and Dr. Zhi Zheng, for their time and great effort in serving on my defense committee.

I am also grateful to the financial support for this research. This work was supported in part by the National Science Foundation Industry/University Cooperative Research Center on Grid-connected Advanced Power Electronic Systems (GRAPES) under Awards GR-17-14 and GR-18-02, and in part by the National Science Foundation under Award ECCS1711617.

Then I should like to express my gratitude to my roommates as well as other classmates who came with me to participate in this exchange program. They have helped me a lot when I was in trouble. Without their companionship and care, I couldn't have been so happy and healthy in the United States for nine months.

Last, I should finally like to express my gratitude to my parents. They often call and chat with me, ask about my life and study and urge me to make progress. Without their concern and encouragement, I couldn't be confident to complete my studies and papers.

Chapter 1 Introduction of energy network

1.1 Research background

Energy is an important foundation of human survival and development, and the driving force for social and economic development. Every industrial revolution is closely related to the innovation of energy types and usage patterns, which promote the development and progress of human society. At present, the third industrial revolution is taking place worldwide. The Energy Internet is the core of the third industrial revolution and the direction of the future development of the energy industry.

1.1.1 Multiple Energy Systems (MES)

The introduction and development of the Energy Internet has profound influence on environment, economy, society, technology and political affairs. It is not only the development trend of the energy system itself, but also the urgent need for the external energy system. With the gradual consumption of traditional fossil energy sources and potential deprivation in environmental problems, the contradiction between future human development and the unsustainable structure of traditional energy sources is constantly sharpening, and the urgent demand for energy supply and structural transformation is increasing worldwide, which makes new energy structures and supply methods proposed.

The dual pressures of energy crisis and environmental pollution have prompted people to reflect on existing energy consumption patterns and begin to study the comprehensive utilization of various forms of energy such as electricity, gas and heat [1-3]. Fully considering

the coupling between different forms of energy such as electricity, heat and gas is an important foundation for building an energy Internet [4-7]. At this stage, various forms of energy in various regions are planned and operated independently.

However, the comprehensive management of various forms of energy may change the future form of energy management and achieve high efficiency in energy production and usage. In addition, this form of energy management leads to a result that various types of energy are increasingly coupled in production, transmission, consumption, etc. For example, in energy production, Combined Heat and Power (CHP) can generate heating energy and cooling energy at the same time of generating electric energy; in energy transmission, gas unit power generation is constrained by the capacity and transmission rate of gas pipeline [8-9]; on the energy consumption side, users can choose to consume different type of energy which can achieve the same effect, such as air conditioning and pipe heating. The strong coupling between multiple energy forms objectively forces people to explore Multiple Energy Systems (MES).

1.1.2 Research status

In the research on the comprehensive utilization of power grids and natural gas networks, the National Renewable Energy Laboratory attaches great importance to the theory and technology of multi-energy integrated systems. The US Department of Energy (DOE) proposed an Integrated Energy System (IES) development plan in 2001. Its research focus on increasing the proportion of renewable energy in the energy supply chain while ensuring the reliability of energy system operation and accelerate the application and promotion of multi-energy integration technologies such as electricity, heat and gas in related fields [9-10]. Switzerland

launched the research project “Vision of Future Energy Networks” in 2003. The biggest feature of the project is the comprehensive consideration of various energy forms to achieve multi-energy system integration to create synergies. The project mainly includes three aspects: the realization of Multi-Energy System modeling; the optimization of the system structure and operation strategy according to the established model; the implementation path diagram from the traditional energy network to the modern energy network [11].

In 2008, Professor Alex Q. Huang of North Carolina State University proposed the concept of the Energy Internet for the first time and launched the “Future renewable electric energy delivery and management (FREEDM) program”. [12-13], the ultimate goal is that in the electricity market, every household can play the role of transmission, distribution, and trading of electricity, which focuses on the distribution of the retail power market. In 2011, Jeremy Rifkin in the United States in the “Third Industrial Revolution” [14] deepen the future of “Energy Internet”, which is the integration of distributed renewable energy and traditional Internet so that multi-source information flow is as easy to transfer as the information flow of traditional Internet.

On May 29th, 2012, the European Union held a conference in Brussels entitled “Growth Task: The Third Industrial Revolution in Europe”. Antonio Tajani, Vice President of the European Council, clearly stated at the meeting that “The third industrial revolution will revolve around the energy Internet.” [15]. Germany is particularly active in the development of the Energy Internet and has pioneered the “E-Energy” program, which seeks to create a new

energy network that enables digital interconnection and computer control and monitoring in the entire energy supply system [16].

Some literatures also elaborate on the structure and function of the Energy Internet in the future human society. Literature [17] proposes that the basic framework of Energy Internet can be divided into two layers, namely “Internet-like networking of the energy system” and “Internet+”. According to the literature [18], the Energy Internet is a multi-energy coordinated complementary network based on renewable energy such as solar energy, wind energy, tidal energy, geothermal energy and biomass energy. According to the literature [19], in the Energy Internet, the energy generation systems and the utilization equipment constitute the “front end”, the energy transportation and conversion configuration constitutes the “network”, and the information network and the intelligent control system constitute the “cloud”. Diversified business and business models constitute “services”. They eventually form a flexible integrated system.

The ETH Zurich Institute first proposed the concept of an energy hub (EH) in the “Future Energy Network Vision” project in 2007 [20]. An energy hub is defined as an input-output port model that describes the exchange, coupling, and relationship between energy, load and network in a Multi-Energy System. The coupling matrix describing the input energy and the output load port can briefly represent various coupling relationships such as conversion, storage and transmission between various forms of energy such as electricity, heat and gas, and plays an important role in the planning and operation research of multi-energy systems.[21]

1.1.3 Energy system resiliency

The concept of resilience originally appeared in the power system. Many accidents in the world in recent years have highlighted the insufficiency and even fragile weakness of the power system for unpredictable extreme disaster events. For example, the earthquakes and tsunami in Japan, the terrorist attacks on the Metcalf substation in California, and the ice disaster in southern China in 2008 caused serious damage to the power system, causing large-scale and long-term power outages, seriously affecting the power supply of the load and residents' lives. Under this circumstance, building a resilient power system is very important for countries to build a stable and efficient smart grid. Extending to a multi-energy system, this conception refers to the ability of multi-energy carrier, such as electricity, heat and gas, to respond to and recover quickly in the face of extreme natural disasters.

The concept of resilience originated in the field of ecology and was later widely used to evaluate the ability of the system to withstand external disturbances and rapid recovery after disturbances. English Resilience is derived from the Latin word “resilio”, which means elasticity, rebound or recovery. Compared to traditional operational risks, resilience needs to be able to withstand small-probability extreme events that are unpredictable during the planning phase of the system, including the increasing number of natural and man-made attacks. This kind of “elasticity” clarifies the new requirements for the energy system: that is, it not only needs to enhance the system's resilience, but also emphasizes that in the face of unavoidable failures, the system can effectively use various resources to flexibly respond to

risks, adapt to changing environments, and maintain operating power as high as possible and restore system's performance quickly and efficiently.

1.2 Energy hub (EH)

1.2.1 Basic concept

The energy hub is like a black box. No matter how complicated the coupling relationship between electricity, heat and gas in a multi-energy system, all kinds of forms of energy input are needed, and finally transformed into other forms of energy as the output of the system. Therefore, such a multi-energy system can be abstracted into an input-output dual-port network as shown in Fig.1, and the middle part of the block is the energy hub module to be analyzed [22].

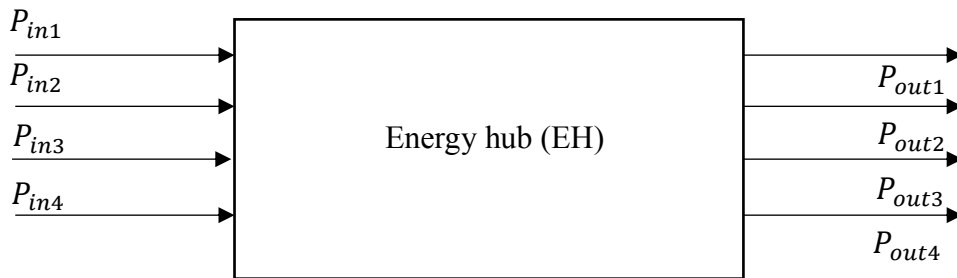

Figure-1-1 Input-output port model for multiple energy system

The P_{in} vector at the left end of the energy hub represents the original energy input of the multi-energy system, such as electric energy, natural gas, photovoltaic, wind energy and other distributed energy input energy, and the P_{out} vector at the right end represents the converted energy output, such as heat, electricity and cold energy, etc.

Therefore, the energy hub on the mathematical level is an input P_{in} to a function that outputs P_{out} :

$$P_{out} = f(P_{in}) \quad (1-1)$$

The function $f(\cdot)$ in the formula can take the transmission, conversion, storage and other aspects of various forms of energy into account [23].

An energy hub (EH) is a highly abstract concept, so as long as an energy system can be modeled reasonably, no matter how large the system is, it can be described by an energy hub. For example, a single residential area, commercial buildings (airports, hospitals, etc.), factories, a region or even a country's energy system [24].

1.2.2 Basic components of EH

The basic components of an energy hub are mainly divided into three parts [25]: energy transmission equipment, energy conversion equipment and energy storage equipment. The energy transmission equipment does not perform any energy conversion and is used to realize direct energy transmission, such as power transmission line, heat network pipeline and gas network pipeline. Energy conversion equipment is used to realize conversion and coupling between different energy forms, or the same energy form Inter-conversions, such as transformers, fuel cells, electric motors, steam and gas turbines and internal combustion engines, etc., which are generally integrated into CCHP. Energy storage devices are batteries, heat storage devices, cold storage devices and gas storage devices.

1.2.3 Energy hub and multi-energy systems

The construction of multi-energy systems will inevitably be a significant change in the current way of energy production, utilization and management. It will also break the barriers of energy production, transmission, storage and consumption, and achieve a breakthrough in energy production to free-consumption operation [26]. Figure 1-2 shows the basic framework of the multi-energy system, from the figure we can see that energy hubs play an important role in multi-energy systems, and they are the center of mutual transformation between multiple energy sources.

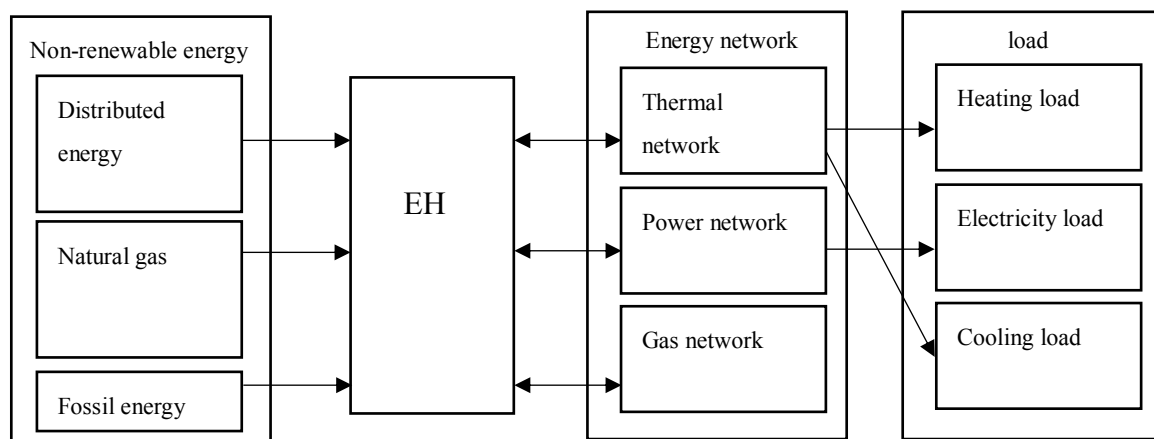

Figure 1-2 Basic architecture of energy internet

1.2.4 Benefits of Energy hub

Using energy hubs to model multi-energy systems and achieve synergistic optimization of various types of energy will fully consider the mutual complement of energy [27-28]. From

the perspective of optimization, the essence of comprehensive optimization of multi-energy systems is to transform the optimization problem of several independent subspaces into a larger global optimization problem. The major benefits of EH are listed in the following:

First of all, improving the economics of the system: Through energy complementation, efficient coordination between infrastructures can be achieved, and duplication of investment can be avoided, thereby reducing system investment costs. At the operational level, energy can be flexibly utilized in different systems to improve energy efficiency [29].

Second, improving the flexibility of the system: On the energy supply side, various forms of energy can be transformed into each other. On the energy consumption side, users can choose different forms of energy to achieve the same goal. This bilateral multi-energy complements the flexibility of the system. For example, during electricity peak time, energy suppliers can use renewable energy and CCHP to generate electricity. In addition, this efficient and flexible transformation can smooth the volatility of loads or new energy output.

Third, increasing the reliability and resilience of the system: Multi-energy systems have a rich supply of energy. On the one hand, various energy sources can be directly transmitted to the consumption side through conduction equipment, and on the other hand, energy supply can be realized through conversion of other energy forms. When one of the transmission lines fails, it can be supplemented immediately by other means to form a mutual aid of various forms of energy and improve the reliability of energy supply. This feature is especially suitable for periods of frequent natural disasters, which can greatly alleviate the shortage of supply of the

original single energy system, and greatly reduce the total cost and energy waste as well as enhance the resilience of the system.

Last of all, improving system complementarity: Multi-energy systems can complement each sub-energy system. For example, through the power system to achieve high-speed, low-loss, long-distance transmission of energy, and through the thermal system and natural gas system to achieve large-scale storage of energy, to stabilize the volatility of energy supply.

1.3 Research outline

1.3.1 Problem description

The climate change has leads to more severe and intense natural disasters over the last few decades. The generation and transmission infrastructure or facility of energy which is directly exposed to these natural disasters would have to endure serious damages more frequently, cities and districts will probably be exposed to potentially large-scale blackouts [24]-[25]. In the United States, natural disasters have caused 80% of major power outages during 2003-2012 [26] which resulted in about \$25 billion economic loss annually [27]. In China, the 2009 ice storm damaged the power grid severely in south China where millions of people suffered a week-long blackout [28]. The model built in this paper is proposed to accommodate random facility outages caused by natural disasters in integrated system/main grid. Not only the power system, but also the natural gas generation and delivery systems are easily to be affected by natural disasters, and different types of disaster will lead to different facility outages and different load curtailments.

Assume that all energy hub (EH) systems are connected to the main network, that is, integrated energy system, including the power and gas network. Each EH system, which is like a node in a power system, can be treated as a node in the integrated energy system, connecting to a bus and delivering energy to customers. Generators and gas wells are separate from EHs. Also, several EHs can be connected through power lines, heating and cooling transmission pipelines to provide energy support to adjacent EHs and complement defective loads when systems come to failure.

On the time scale, the entire optimization process is divided into two stages. Stage 1 refers to the one during which the system normally supplies the load before the disaster, and stage 2 refers to the one in which the system remediates according to all disaster situations that may occur during the disaster. Stage 2 includes several different scenarios, the difference between each scenario is that the degree of disaster that may occur is different. Each scenario corresponds to an occurrence probability, and the ability of a system to actually deliver energy after being destroyed. Through forecasting, decision makers can get relevant data about possible disasters in the previous stage of the disaster, and the ultimate goal of the second stage is that the expectation of this series of possible scenarios is optimal, which is the most secure solution.

Stage 1 mainly considers the normal operating cost of the system, no load shedding. Only normal electrical energy complements between different eh systems. Stage 2 mainly considers the operating cost of the system and the corresponding load shedding cost after the disaster occurs. In addition to complementary electrical energy, the EH system also complements the

cold and thermal energy, so that the important load of each system be retained so that system is as stable as possible.

The objective of this problem is to minimize the whole operation cost as well as the load curtailment of multi-EH system. The expectation of punishing fees of load curtailment and operation costs of all possible scenarios must be minimized so that the optimal solution the day before disaster can be made.

1.3.2 Major contributions

1) Focusing on the operation cost of energy storage equipment and its self-loss cost in both two stages, as the damage degree of disaster in stage 2 will have significant influence on the decision made by operators in stage 1. The operator must reasonably distribute the system energy including energy storing or releasing value, energy purchasing or selling value and load curtailment value of stage 1, while taking into account the optimization of the objective function of stage 2.

2) Energy remaining capacity, storing and releasing of energy storage system are considered in detail in the model, determining the purchase of electricity and gas, energy distribution, storage and load curtailment at the next moment.

3) Load priority is set so that under the premise that the total load curtailment is the same, the most important load can be reduced the least, and the users' side requirements can be best satisfied. Each EH has different importance weight, which means energy complementation can be made between different EHs according to different characteristics of load curves.

Chapter 2 Single energy hub model

2.1 Basic structure

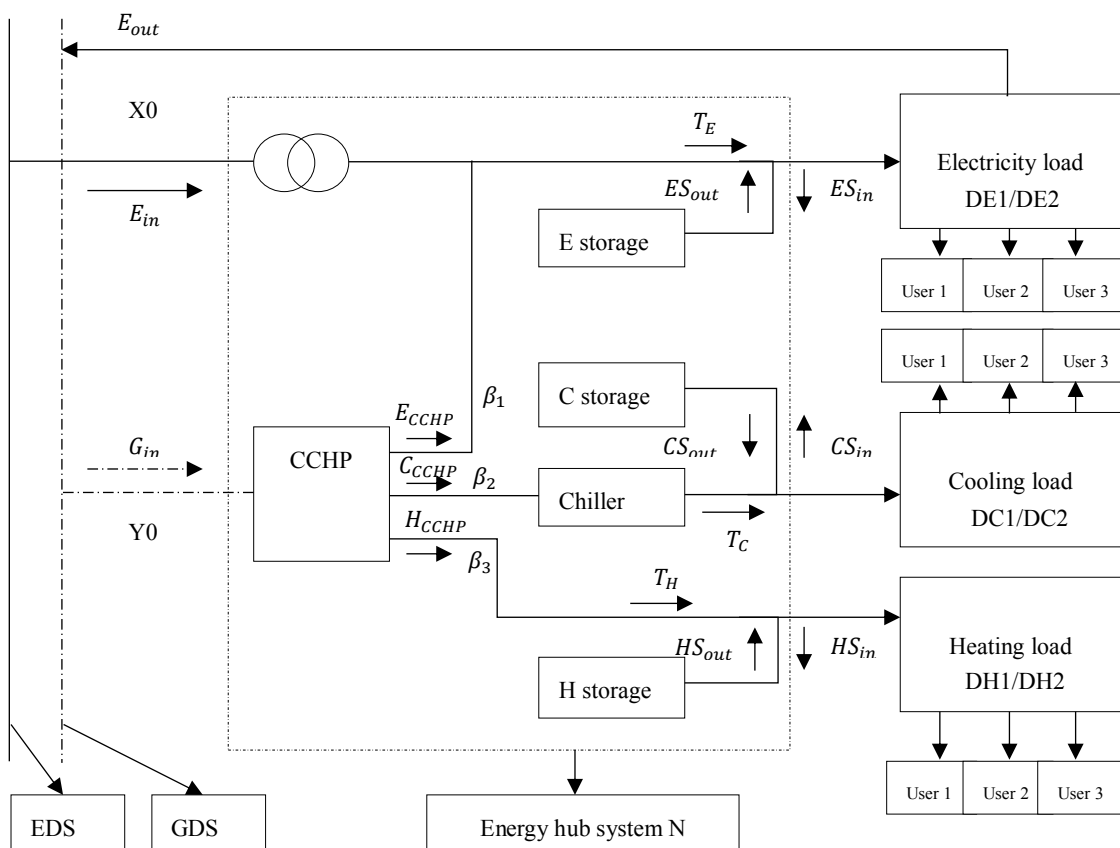

Figure 2-1 Structure of one typical EH system

Energy hub consists of three parts: Input, dispatch/transmission system and output. In this model, Input includes electricity from electricity distribution system (EDS) E_{in} , whose value is expressed by X_0 , and natural gas from gas distribution system (GDS) G_{in} , whose value is expressed by Y_0 . X_0 can be negative when the users' power is excessive so that the power is reversed to the main grid. X_0 and Y_0 include two parts respectively, X_{01} , X_{02} , and Y_{01} , Y_{02} .

X_{01} means the electricity purchasing value in stage 1 while X_{02} means the electricity purchasing value in stage 2, Y_{01} means the natural gas purchasing value in stage 1 while Y_{02} means the natural gas purchasing value in stage 2.

$$X_{02,i} = [X_{02,i,1} \quad X_{02,i,2} \quad \dots \quad X_{02,i,k} \quad \dots \quad X_{02,i,24}] \quad (2-1-1)$$

$$Y_{02,i} = [Y_{02,i,1} \quad Y_{02,i,2} \quad \dots \quad Y_{02,i,k} \quad \dots \quad Y_{02,i,24}] \quad (2-1-2)$$

where

$X_{02,i,k}$ is the electricity purchasing value from main grid in moment k of scenario i.

$Y_{02,i,k}$ is the natural gas purchasing value from main grid in moment k of scenario i.

Generator and gas well are connected to the main grid which coupled with EDS and GDS through buses and EHs. Output includes electricity, cooling and heating loads which can be delivered into different users with different load importance, which can be called load priority. Load priority is designed to protect the normal operation of the most important load of the users in the event of a disaster, when the energy is not fully supplied, and to take the lead in removing a part of the relatively unimportant load.

The middle part, which consists of energy conversion and transfer facilities, is represented by the coupling function $f(\cdot)$, which includes transformer, CCHP, chiller and energy storage of electricity, cooling and heating, respectively. CCHP, which convert a portion of natural gas into electricity and convert another portion of natural gas into heating and cooling energy, can be considered as distributed generator (DG) in power system. Energy storage system is a strong

backup support both for demand side and supply side. When the users' load cannot be satisfied, the EH system needs to use the remaining energy in the energy storage system while buying electricity and natural gas to the main network. When the users' load can be satisfied and the energy supply is surplus, the user will store the excess energy in the energy storage system and even send it back to the main power grid.

2.1.1 CCHP model

CCHP has its dispatch factors, β_1 , β_2 , β_3 , which represent electricity, cooling and heating output distribution respectively. They are not fixed but determined by the SOC of ESS and load demand at each moment.

$$\beta_1 + \beta_2 + \beta_3 = 1 \quad (2-1-3)$$

$$E_{CCHP} = \beta_1 \eta_{CCHP} Y_0 CV \quad (2-1-4)$$

$$C_{CCHP} = \beta_2 \eta_{CCHP} Y_0 CV \quad (2-1-5)$$

$$H_{CCHP} = \beta_3 \eta_{CCHP} Y_0 CV \quad (2-1-6)$$

where

E_{CCHP} , C_{CCHP} and H_{CCHP} are defined to represent the electricity, cooling and heating output value of CCHP which have a close relationship with dispatch factor β , β is an Intermediate variables, which will be offset in the later formula. Relationships between CCHP

outputs are explained in (2-1-7), which means that the electricity output and thermal demand, including heating and cooling, are restricted against each other [22].

$$E_{CCHP} = \left(\frac{H_{CCHP}}{\delta_{heat}} + \frac{C_{CCHP}}{\delta_{cool}} \right) \frac{\eta_{CCHP_E}}{\eta_{CCHP_T}} \quad (2-1-7)$$

$$\eta_{CCHP_T} = 1 - \eta_{CCHP_E} - \eta_{loss} \quad (2-1-8)$$

where

δ_{heat} is the heating coefficient.

δ_{cool} is the cooling coefficient.

η_{CCHP_E} is the transfer efficiency of electricity of CCHP.

η_{CCHP_T} is the transfer efficiency of thermal of CCHP.

η_{loss} is the heat loss factor of CCHP

$$\left(\frac{H_{CCHP}}{\delta_{heat}} + \frac{C_{CCHP}}{\delta_{cool}} \right) = Y_0 * CV * \eta_{CCHP_T} \quad (2-1-9)$$

$$E_{CCHP} = Y_0 * CV * \eta_{CCHP_E} \quad (2-1-10)$$

$$C_{CCHP_E} \geq E_{CCHP} \geq 0, C_{CCHP_C} \geq C_{CCHP} \geq 0, C_{CCHP_H} \geq H_{CCHP} \geq 0 \quad (2-1-11)$$

where

Y_0 is natural gas bought from main grid, that is gas input value, the unit is cubic meter.

CV is calorific value of natural gas, indicates the equivalent energy value of natural gas per cubic meter.

C_{CCHP_E} , C_{CCHP_C} , C_{CCHP_H} refer to the production capacity of electricity, cooling and heating in CCHP respectively.

The relationship between the CCHP input value of natural gas and the output value of heating energy and cooling energy is shown in equation (2-1-9), the relationship between the CCHP input value of natural gas and the output value of electricity is shown in equation (2-1-10). Equation (2-1-9) and (2-1-10) show specific energy balance between input and output of CCHP. Equation (2-1-11) expresses that the output of CCHP must not be negative while within production capacity constraints.

To determine β according to load demand, energy constraints are formed, which are shown in equation (2-1-12)-(2-1-14). In order to make the expression simple in the following formulas, T_E , T_C and T_H are used to represent the transmission energy in the system and they are all Intermediate variables.

$$T_E = E_{CCHP} + X_0 \quad (2-1-12)$$

$$T_C = C_{CCHP} * \eta_C \quad (2-1-13)$$

$$T_H = H_{CCHP} \quad (2-1-14)$$

where

η_C is the efficiency factor of chiller.

T_E , T_C , T_H are the transmission energy supplying electricity, cooling and heating energy to the users, T_E includes the electricity output of CCHP and the one bought from main grid.

On the demand side, the energy balance relationship can be expressed as,

$$T_{E,g,k,i} = E_{IN,g,k,i}\eta_{E,IN} - \frac{E_{OUT,g,k,i}}{\eta_{E,OUT}} + D_{E,g,k} - L_{eci,g,k} \quad (2-1-15)$$

$$T_{C,g,k,i} = C_{IN,g,k,i}\eta_{C,IN} - \frac{C_{OUT,g,k,i}}{\eta_{C,OUT}} + D_{C,g,k} - L_{cci,g,k} \quad (2-1-16)$$

$$T_{H,g,k,i} = H_{IN,g,k,i}\eta_{H,IN} - \frac{H_{OUT,g,k,i}}{\eta_{H,OUT}} + D_{H,g,k} - L_{hci,g,k} \quad (2-1-17)$$

where

$T_{E,g,k,i}$, $T_{C,g,k,i}$, $T_{H,g,k,i}$ refer to the electricity, cooling and heating transmission energy of scenario i in stage g and moment k respectively.

$E_{IN,g,k,i}/E_{OUT,g,k,i}$, $C_{IN,g,k,i}/C_{OUT,g,k,i}$, $H_{IN,g,k,i}/H_{OUT,g,k,i}$ refer to the energy stored (IN) and released (OUT) by electricity, cooling and heating energy storage system (ESS) of scenario i in stage g and moment k respectively. The specific content will be introduced in detail in the energy storage model section.

$\eta_{E,IN}$, $\eta_{C,IN}$, $\eta_{H,IN}$ refer to efficiency of energy charging of ESS.

$\eta_{E,OUT}$, $\eta_{C,OUT}$, $\eta_{H,OUT}$ refer to efficiency of energy releasing of ESS.

$D_{E,g,k}$, $D_{C,g,k}$, $D_{H,g,k}$ refer to the load demand of electricity, cooling and heating in stage g in moment k . g may have a value of 1 or 2.

$L_{eci,g,k}$, $L_{cci,g,k}$, $L_{hci,g,k}$ refer to the load curtailment value of electricity, cooling and heating of scenario i in stage g and moment k . When g equals to 1, which means the system is now in the optimization of stage 1, load curtailment is set to 0. The specific energy balance equations of stage 1 are as follows:

$$T_{E,k,i} = E_{IN,k,i} \eta_{E,IN} - \frac{E_{OUT,k,i}}{\eta_{E,OUT}} + D_{E1,k} \quad (2-1-18)$$

$$T_{C,k,i} = C_{IN,k,i} \eta_{C,IN} - \frac{C_{OUT,k,i}}{\eta_{C,OUT}} + D_{C1,k} \quad (2-1-19)$$

$$T_{H,k,i} = H_{IN,k,i} \eta_{H,IN} - \frac{H_{OUT,k,i}}{\eta_{H,OUT}} + D_{H1,k} \quad (2-1-20)$$

where

$\beta_1, \beta_2, \beta_3, T_E, T_C, T_H$ and $E_{CCHP}, C_{CCHP}, H_{CCHP}$ are all intermediate variables, when the equations are simplified, they will disappear. They exist only to make the expression of the formula concise and clear.

The core of the CCHP model is the conservation of energy between the power supply side and the load demand side. The production ratio of electrical and thermal energy in CCHP is affected by its internal structure on the one hand and by the change of the load curve on the other hand, so its constraints include internal (equation (2-1-7)-(2-1-8)) and external (equation (2-1-9)-(2-1-20)) two parts.

2.1.2 Chiller model

The CCHP system actually produces only two kinds of energy, thermal energy and electric energy, in which part of the thermal energy is directly supplied to the heating load, and the other part is supplied to the chiller to be converted into cooling energy to meet the users' cooling load, and a cooling storage device is added for adjustment.

$$T_C = C_{CCHP} * \eta_C \quad (2-1-21)$$

$$C_{CCHP} = \frac{\beta_2}{\beta_2 + \beta_3} * T_{CCHP} \quad (2-1-22)$$

$$T_{CCHP} = H_{CCHP} + C_{CCHP} \quad (2-1-23)$$

where

T_C is the output value of chiller.

C_{CCHP} is the input value of chiller, that is the effective cooling output of CCHP.

η_C is the transfer efficiency of chiller.

T_{CCHP} is total thermal output of CCHP, including heating and cooling.

2.1.3 Load model

Load demand from customer side in the first and second stage at moment k are as follows.

$$\mathbf{D}_E = \begin{bmatrix} D_{E1,1} & D_{E1,2} & \dots & D_{E1,k} & \dots & D_{E1,24} \\ D_{E2,1} & D_{E2,2} & \dots & D_{E2,k} & \dots & D_{E2,24} \end{bmatrix} \quad (2-1-24)$$

$$\mathbf{D}_C = \begin{bmatrix} D_{C1,1} & D_{C1,2} & \dots & D_{C1,k} & \dots & D_{C1,24} \\ D_{C2,1} & D_{C2,2} & \dots & D_{C2,k} & \dots & D_{C2,24} \end{bmatrix} \quad (2-1-25)$$

$$\mathbf{D}_H = \begin{bmatrix} D_{H1,1} & D_{H1,2} & \dots & D_{H1,k} & \dots & D_{H1,24} \\ D_{H2,1} & D_{H2,2} & \dots & D_{H2,k} & \dots & D_{H2,24} \end{bmatrix} \quad (2-1-26)$$

$D_{Eg,k}$ denotes electricity demand in stage g in moment k, the same as cooling and heating load, g varies from 1 to 2. The difference of net load between stage 1 and stage 2 is that the second stage has load curtailment which helps to enhance the system resiliency and stability when natural disaster happens.

In order to meet the demand to the greatest extent, guarantee the normal supply of important loads, the load is divided into three levels, each level corresponds to an importance multiplier a_j , which is used to measure the punishing fees added to the system operating cost after load curtailment. For the sake of convenience, a_j , the importance multiplier of the cold and hot electric load in each EH system is set to be the same.

$$\mathbf{D}_E = \begin{bmatrix} D_{E1,1} & D_{E1,2} & \cdots & D_{E1,k} & \cdots & D_{E1,24} \\ D_{E2,1} & D_{E2,2} & \cdots & D_{E2,k} & \cdots & D_{E2,24} \end{bmatrix} = \sum_{j=1}^3 \mathbf{D}_{ej} \quad (2-1-27)$$

$$\mathbf{D}_C = \begin{bmatrix} D_{C1,1} & D_{C1,2} & \cdots & D_{C1,k} & \cdots & D_{C1,24} \\ D_{C2,1} & D_{C2,2} & \cdots & D_{C2,k} & \cdots & D_{C2,24} \end{bmatrix} = \sum_{j=1}^3 \mathbf{D}_{cj} \quad (2-1-28)$$

$$\mathbf{D}_H = \begin{bmatrix} D_{H1,1} & D_{H1,2} & \cdots & D_{H1,k} & \cdots & D_{H1,24} \\ D_{H2,1} & D_{H2,2} & \cdots & D_{H2,k} & \cdots & D_{H2,24} \end{bmatrix} = \sum_{j=1}^3 \mathbf{D}_{hj} \quad (2-1-29)$$

$$\mathbf{D}_{ej} = \begin{bmatrix} D_{ej,1,1} & D_{ej,1,2} & \cdots & D_{ej,1,k} & \cdots & D_{ej,1,24} \\ D_{ej,2,1} & D_{ej,2,2} & \cdots & D_{ej,2,k} & \cdots & D_{ej,2,24} \end{bmatrix} \quad (2-1-30)$$

$$\mathbf{D}_{cj} = \begin{bmatrix} D_{cj,1,1} & D_{cj,1,2} & \cdots & D_{cj,1,k} & \cdots & D_{cj,1,24} \\ D_{cj,2,1} & D_{cj,2,2} & \cdots & D_{cj,2,k} & \cdots & D_{cj,2,24} \end{bmatrix} \quad (2-1-31)$$

$$\mathbf{D}_{hj} = \begin{bmatrix} D_{hj,1,1} & D_{hj,1,2} & \cdots & D_{hj,1,k} & \cdots & D_{hj,1,24} \\ D_{hj,2,1} & D_{hj,2,2} & \cdots & D_{hj,2,k} & \cdots & D_{hj,2,24} \end{bmatrix} \quad (2-1-32)$$

$$D_{E1,k} = \sum_{j=1}^3 D_{ej,1,k} \quad (2-1-33)$$

$$D_{E2,k} = \sum_{j=1}^3 D_{ej,2,k} \quad (2-1-34)$$

$$D_{C1,k} = \sum_{j=1}^3 D_{cj,1,k} \quad (2-1-35)$$

$$D_{C2,k} = \sum_{j=1}^3 D_{cj,2,k} \quad (2-1-36)$$

$$D_{H1,k} = \sum_{j=1}^3 D_{hj,1,k} \quad (2-1-37)$$

$$D_{H2,k} = \sum_{j=1}^3 D_{hj,2,k} \quad (2-1-38)$$

Expression (2-1-27)-(2-1-38) represent the conception of load demand and different load level settings in this model. \mathbf{D}_{e1} , \mathbf{D}_{e2} , \mathbf{D}_{e3} denote the actual value of primary load, secondary load and tertiary load respectively, whose importance is decreasing one by one. The components in vector \mathbf{D}_{e1} are called $D_{e1,1,k}$, which means electricity load demand of the first priority in moment k of stage 2, for example. The same as cooling and heating energy load demand. In a word, the load demands in the users' side are divided into 3 levels which represent users of different levels, each load level includes 2 stage values.

a_1 , a_2 , a_3 correspond to \mathbf{D}_{e1} , \mathbf{D}_{e2} , \mathbf{D}_{e3} in turn which will be used in the following objective function to express different punishing fees. The same as heating and cooling load, corresponding to factor b_j and c_j , j varies from 1 to 3. Load curtailment cost function and constraints are as follows:

$$W_{cur 2} = \eta_1 L_{eci,2,k} + \eta_2 L_{cci,2,k} + \eta_3 L_{hci,2,k} \quad (2-1-39)$$

$$L_{eci,2,k} = \sum_{j=1}^3 a_j * l_{ej,i,2,k} \quad (2-1-40)$$

$$L_{cci,2,k} = \sum_{j=1}^3 b_j * l_{cj,i,2,k} \quad (2-1-41)$$

$$L_{hci,2,k} = \sum_{j=1}^3 c_j * l_{hj,i,2,k} \quad (2-1-42)$$

$$0 \leq L_{eci,2,k} \leq D_{E2,k} \quad (2-1-43)$$

$$0 \leq L_{cci,2,k} \leq D_{C2,k} \quad (2-1-44)$$

$$0 \leq L_{hci,2,k} \leq D_{H2,k} \quad (2-1-45)$$

$$l_{ej,i,2,k} \leq D_{ej,2,k} \quad (2-1-46)$$

$$l_{cj,i,2,k} \leq D_{cj,2,k} \quad (2-1-47)$$

$$l_{hj,i,2,k} \leq D_{hj,2,k} \quad (2-1-48)$$

where

$W_{cur 2}$ is the total load curtailment cost in stage 2.

η_1, η_2, η_3 refer to the punishing factors of electricity, cooling and heating load curtailment.

$L_{eci,2,k}, L_{cci,2,k}, L_{hci,2,k}$ refer to the weighted value of load curtailment in moment k.

$a_j/b_j/c_j$ is the importance multiplier which stand for the punishing fees added to the system operating cost after load curtailment. The larger j, the less important the load is.

$l_{ej,i,2,k}, l_{cj,i,2,k}, l_{hj,i,2,k}$ refer to actual load value for each level of electricity, cooling and heating load in scenario i, moment k of stage 2.

$D_{E2,k}/D_{C2,k}/D_{H2,k}$ refer to the load demand

Expression (2-1-39) refers to the objective function of load curtailment punishing fees.

Each type of energy corresponds to specific multiplier η which denotes different value of electricity, cooling and heating energy. Expression (2-1-40)-(2-1-42) mean that weighted value

of load curtailment was divided into three grades, multiplier a, b and c represent the power output value of the load, which can represent economic loss caused by load cutting. Expression (2-1-43)-(2-1-45) mean that load curtailment must be smaller than the total load demand. Expression (2-1-46)-(2-1-48) mean that the amount of load cutting at each level must be less than the total load at that level.

2.1.4 Energy storage model

Energy storage system plays the role of peak load shifting. When the energy supply of the main network is insufficient, energy storage can replace the generator and the natural gas well to become the supply side. When the main network energy supply is sufficient, the energy storage can become the load side and store the redundant energy temporarily, when the load side needs it, the main network power supply is added to supplement the load, thereby improving the network operation efficiency and saving the total cost. The energy storage system is an important means of balancing and regulating energy in the energy network, it is a key part of energy hub module. During the optimization process, the energy storage and discharge values at each moment are the only independent variables, whether the amount of electricity and gas purchased from the main network or the distribution ratio of electricity, heating and cooling in the production process of CCHP, are controlled by energy storage variables. The remaining capacity of energy storage [34] can be expressed as:

In stage 1, the energy storage models are as follows,

$$E_{S,k+1} = E_{S,k}(1 - \mu_{E,IN}) + E_{IN,k+1}\eta_{E,IN} - \frac{E_{OUT,k+1}}{\eta_{E,OUT}} \quad (2-1-49)$$

$$0 \leq E_{IN,k}\eta_{E,IN} \leq E_S^{max} z_{se1} \quad (2-1-50)$$

$$0 \leq \frac{E_{OUT,k}}{\eta_{E,OUT}} \leq E_S^{max}(1 - z_{se1}) \quad (2-1-51)$$

$$0 \leq E_{S,k} \leq E_{S1}^{max} \quad (2-1-52)$$

$$C_{S,k+1} = C_{S,k}(1 - \mu_{C,IN}) + C_{IN,k+1}\eta_{C,IN} - \frac{C_{OUT,k+1}}{\eta_{C,OUT}} \quad (2-1-53)$$

$$0 \leq C_{IN,k}\eta_{C,IN} \leq C_S^{max} z_{sc1} \quad (2-1-54)$$

$$0 \leq \frac{C_{OUT,k}}{\eta_{C,OUT}} \leq C_S^{max}(1 - z_{sc1}) \quad (2-1-55)$$

$$0 \leq C_{S,k} \leq C_{S1}^{max} \quad (2-1-56)$$

$$H_{S,k+1} = H_{S,k}(1 - \mu_{H,IN}) + H_{IN,k+1}\eta_{H,IN} - \frac{H_{OUT,k+1}}{\eta_{H,OUT}} \quad (2-1-57)$$

$$0 \leq H_{IN,k}\eta_{H,IN} \leq H_S^{max} z_{sh1} \quad (2-1-58)$$

$$0 \leq \frac{H_{OUT,k}}{\eta_{H,OUT}} \leq H_S^{max}(1 - z_{sh1}) \quad (2-1-59)$$

$$0 \leq H_{S,k} \leq H_{S1}^{max} \quad (2-1-60)$$

where

$E_{S,k}/C_{S,k}/H_{S,k}$ is the state of charge (SOC) of electricity, cooling and heating energy storage at moment k.

$\mu_{E,IN}/\mu_{C,IN}/\mu_{H,IN}$ is the self-loss rate of electricity, cooling and heating energy storage, it represents the capacity change problem that occurs when the energy storage device gradually ages with time.

$E_{IN,k+1}/C_{IN,k+1}/H_{IN,k+1}$ refer to the storing energy of electricity, cooling and heating energy at moment k+1.

$E_{OUT,k+1}/C_{OUT,k+1}/H_{OUT,k+1}$ refer to the releasing energy of electricity, cooling and heating energy at moment k+1.

$\eta_{E,IN}/\eta_{C,IN}/\eta_{H,IN}$ refer to efficiency of energy charging.

$\eta_{E,OUT}/\eta_{C,OUT}/\eta_{H,OUT}$ refer to efficiency of energy releasing.

$E_S^{max}/C_S^{max}/H_S^{max}$ means each time's charging and discharging capacity of electricity, cooling and heating storage.

$E_{S1}^{max}/C_{S1}^{max}/H_{S1}^{max}$ means total capacity of electricity, cooling and heating storage.

$z_{se1}/z_{sc1}/z_{sh1}$ is the binary variable in stage 1 which denotes the operation state of electricity, cooling and heating storage system, storage system work in the charging mode when its value is 1 and vice versa.

Expression (2-1-49)-(2-1-52) denote the electricity storage constraints. Expression (2-1-49) shows the relationship of energy storage device's SOC between moment k and moment k+1, which is related to the self-loss coefficient μ_{IN} , the efficiency of energy charging η_{IN} and discharging η_{OUT} , and the amount of each time's charge and discharge. Expression (2-1-50)-(2-1-52) shows the operation constraints of each time's charging and discharging and total capacity.

In stage 2, the energy storage models are in the following,

$$E_{S,i,k+1} = E_{S,i,k}(1 - \mu_{E,IN}) + E_{IN,i,k+1}\eta_{E,IN} - \frac{E_{OUT,i,k+1}}{\eta_{E,OUT}} \quad (2-1-61)$$

$$0 \leq E_{IN,i,k}\eta_{E,IN} \leq E_S^{max} z_{se2,i} \quad (2-1-62)$$

$$0 \leq \frac{E_{OUT,i,k}}{\eta_{E,OUT}} \leq E_S^{max}(1 - z_{se2,i}) \quad (2-1-63)$$

$$0 \leq E_{S,i,k} \leq E_{S1}^{max} \quad (2-1-64)$$

$$C_{S,i,k+1} = C_{S,i,k}(1 - \mu_{C,IN}) + C_{IN,i,k+1}\eta_{C,IN} - \frac{C_{OUT,i,k+1}}{\eta_{C,OUT}} \quad (2-1-65)$$

$$0 \leq C_{IN,i,k}\eta_{C,IN} \leq C_S^{max} z_{sc2,i} \quad (2-1-66)$$

$$0 \leq \frac{C_{OUT,i,k}}{\eta_{C,OUT}} \leq C_S^{max}(1 - z_{sc2,i}) \quad (2-1-67)$$

$$0 \leq C_{S,i,k} \leq C_{S1}^{max} \quad (2-1-68)$$

$$H_{S,i,k+1} = H_{S,i,k}(1 - \mu_{H,IN}) + H_{IN,i,k+1}\eta_{H,IN} - \frac{H_{OUT,i,k+1}}{\eta_{H,OUT}} \quad (2-1-69)$$

$$0 \leq H_{IN,i,k}\eta_{H,IN} \leq H_S^{max} z_{sh2,i} \quad (2-1-70)$$

$$0 \leq \frac{H_{OUT,i,k}}{\eta_{H,OUT}} \leq H_S^{max}(1 - z_{sh2,i}) \quad (2-1-71)$$

$$0 \leq H_{S,i,k} \leq H_{S1}^{max} \quad (2-1-72)$$

where

$E_{S,i,k}/C_{S,i,k}/H_{S,i,k}$ is the state of charge (SOC) of electricity, cooling and heating energy storage at moment k of scenario i.

$\mu_{E,IN}/\mu_{C,IN}/\mu_{H,IN}$ is the self-loss rate of electricity, cooling and heating energy storage, it represents the capacity change problem that occurs when the energy storage device gradually ages with time.

$E_{IN,i,k+1}/C_{IN,i,k+1}/H_{IN,i,k+1}$ refer to the storing energy of electricity, cooling and heating energy at moment k+1 of scenario i.

$E_{OUT,i,k+1}/C_{OUT,i,k+1}/H_{OUT,i,k+1}$ refer to the releasing energy of electricity, cooling and heating energy at moment k+1 of scenario i.

$\eta_{E,IN}/\eta_{C,IN}/\eta_{H,IN}$ refer to efficiency of energy charging.

$\eta_{E,OUT}/\eta_{C,OUT}/\eta_{H,OUT}$ refer to efficiency of energy releasing.

$E_S^{max}/C_S^{max}/H_S^{max}$ means each time's charging and discharging capacity of electricity, cooling and heating storage.

$E_{S1}^{max}/C_{S1}^{max}/H_{S1}^{max}$ means total capacity of electricity, cooling and heating storage.

$z_{se2,i}/z_{sc2,i}/z_{sh2,i}$ is the binary variable in scenario i in stage 2 which denotes the operation state of electricity, cooling and heating storage system, storage system work in the charging mode when its value is 1 and vice versa.

Expression (2-1-61)-(2-1-72) are as same meaning as expression (2-1-49)-(2-1-60), the difference between these two series of equations is in the second stage, there are several scenarios. Each scenario has its own result, corresponding to the energy storage and releasing values in different disaster scenarios.

2.2 Scenario design

In stage 2, different scenarios mean different energy transmission rates, which is expressed as S_{E_i} and S_{G_i} , S_{E_i} refers to the electricity one, and S_{G_i} refers to the natural gas one, i is the index of scenario. The energy transmission rate refers to the energy transmission capacity of the transmission line connecting the main network and the EH module when the electricity network and the natural gas network purchase energy from the main network.

Each scenario corresponds to one specific type of disaster which will cause different degrees of damage or even disconnection of power transmission lines and natural gas pipelines.

$$S_{E_i} = [S_{E1,i} \quad S_{E2,i} \quad \dots \quad S_{Ek,i} \quad \dots \quad S_{E24,i}] \quad (2-2-1)$$

$$S_{G_i} = [S_{G1,i} \quad S_{G2,i} \quad \dots \quad S_{Gk,i} \quad \dots \quad S_{G24,i}] \quad (2-2-2)$$

where

$S_{Ek,i}$, $S_{Gk,i}$ vary from 0 to 1, representing the transmission rate caused by natural disasters. In extreme cases, $S_{Ek,i} = 0$ or $S_{Gk,i} = 0$ when full damage outage occurs, $S_{Ek,i} = 1$ or $S_{Gk,i} = 1$ when the outage doesn't occur. Disasters can cause damage to transmission lines/gas pipelines, which is represented by the value of energy inputs, so different scenarios correspond to different levels of input. In the constraint equations, S_{E_i} and S_{G_i} is the multiplier of the line's maximum transmission capacity, that is, under normal circumstances, capacity of

transmission line and pipeline are C_l and C_p , under failure scenarios, capacity of transmission line and pipeline are $C_l * S_{E_i}$ and $C_p * S_{G_i}$.

In this single EH optimization problem, the transmission efficiency matrix S_E and S_G are set as follows:

$$S_E = \begin{bmatrix} 0.25 & 0.2 & 0.2 & 0.2 & 0 & 0 & 0 & 0 & 0 & 0 & 0 & 0 & 0 & 0 & 0 & 0.1 & 0.15 & 0.22 & 0.25 & 0.3 & 0.4 & 1 & 1 & 1 & 1 \\ 0 & 0 & 0 & 0 & 0 & 0 & 0 & 0 & 0 & 0 & 0 & 0 & 0 & 0 & 0 & 0 & 0 & 0 & 0 & 0.1 & 0.15 & 0.26 & 0.3 & 0.4 \\ 0 & 0 & 0 & 0 & 0 & 0 & 0 & 0 & 0 & 0 & 0 & 0 & 0 & 0 & 0 & 0 & 0 & 0 & 0 & 0.1 & 0.23 & 0.3 & 0.4 & 0.45 & 0.5 \\ 0 & 0 \\ 0.8 & 0.8 & 0.8 & 0.8 & 0.8 & 0.8 & 0.4 & 0.4 & 0.2 & 0.2 & 0.1 & 0.1 & 0 & 0 & 0 & 0 & 0.2 & 0.2 & 0.3 & 0.3 & 0.6 & 0.6 & 0.7 & 0.75 \end{bmatrix} \quad (2-2-3)$$

$$S_G = \begin{bmatrix} 0 & 0 & 0 & 0 & 0 & 0 & 0 & 0 & 0 & 0 & 0 & 0 & 0 & 0 & 0.1 & 0.1 & 0.2 & 0.2 & 0.2 & 0.25 & 0.25 & 0.3 & 0.3 & 0.3 \\ 0 & 0 & 0 & 0 & 0.1 & 0.15 & 0 & 0 & 0 & 0 & 0 & 0 & 0 & 0 & 0 & 0 & 0 & 0.1 & 0.4 & 1 & 1 & 1 & 1 & 1 \\ 0 & 0 \\ 0.35 & 0.3 & 0.3 & 0.2 & 0.2 & 0.15 & 0.15 & 0.1 & 0.1 & 0.1 & 0 & 0 & 0 & 0 & 0 & 0 & 0.2 & 0.2 & 0.3 & 0.3 & 0.6 & 0.6 & 0.7 & 0.9 \\ 0 & 0 \end{bmatrix} \quad (2-2-4)$$

The row vector represents different scenario, and each row vector has 24 values which represent the energy transmission rate of each moment in this scenario.

2.3 Problem description

2.3.1 Mathematical expression

The proposed two stage problem is stated in a compact form:

Objective function:

$$f = \min\{W_{ope1} + E(W_{cur2} + W_{ope2})\} \quad (2-3-1)$$

The first part of the objective function W_{ope1} means the operation cost of first stage, the second part is $E(W_{cur2} + W_{ope2})$ which means the expectation value of the total cost of second stage, including load curtailment punishing fees W_{cur2} and operation cost W_{ope2} .

Subject to:

$$(2-1-1)-(2-1-20)$$

$$(2-1-21)-(2-1-23)$$

$$(2-1-39)-(2-1-48)$$

$$(2-1-49)-(2-1-72)$$

$$W_{ope1} = \max(\mathbf{X}_{01}, \mathbf{0}) * \mathbf{W}_1^T + \min(\mathbf{X}_{01}, \mathbf{0}) * \mathbf{Q}_1^T + \mathbf{Y}_{01} \mathbf{V}_1^T \quad (2-3-2)$$

$$W_{ope2} = \max(\mathbf{X}_{02,i}, \mathbf{0}) * \mathbf{W}_2^T + \min(\mathbf{X}_{02,i}, \mathbf{0}) * \mathbf{Q}_2^T + \mathbf{Y}_{02,i} * \mathbf{V}_2^T \quad (2-3-3)$$

$$X_{01} \leq C_T, X_{01} \leq C_l \quad (2-3-4)$$

$$0 \leq Y_{01} \leq C_p \quad (2-3-5)$$

$$X_{02,i} \leq C_T, X_{02,i} \leq C_l * S_{E_i} \quad (2-3-6)$$

$$0 \leq Y_{02,i} \leq C_p * S_{G_i} \quad (2-3-7)$$

where

$\mathbf{W}_1/\mathbf{W}_2$ is the vector of electricity purchasing price from main grid in stage 1 and in stage 2 respectively, $\mathbf{W}_1^T/\mathbf{W}_2^T$ is the transposition value of $\mathbf{W}_1/\mathbf{W}_2$.

$\mathbf{Q}_1/\mathbf{Q}_2$ is the vector of electricity selling price back to the main grid in stage 1 and in stage 2 respectively, $\mathbf{Q}_1^T/\mathbf{Q}_2^T$ is the transposition value of $\mathbf{Q}_1/\mathbf{Q}_2$.

V_1/V_2 is the vector of natural gas purchasing price from main grid in stage 1 and in stage 2 respectively, V_1^T/V_2^T is the transposition value of V_1/V_2 .

C_T is the maximum capacity of transformer.

C_l is the maximum capacity of electricity transmission line.

C_p is the maximum capacity of natural gas transmission pipeline.

Constraint (2-1-1)-(2-1-20) represent the energy dispatch within CCHP and energy balance between CCHP and the main grid. Equation (2-1-21)-(2-1-23) represent the input and output relationship of chiller. (2-1-39)-(2-1-48) represent the load energy balance between ES, CCHP and load demand, energy storage operation constraint between moments as well as single charge and discharge limits and total capacity of energy storage. (2-3-2)-(2-3-3) denote the operation cost in stage 1 and 2 respectively, W and Q mean electricity buying and selling price respectively, V means gas buying price, and the subscripts 1 and 2 indicate different stages. (2-1-39)-(2-1-42) represent the punishing fees of load curtailment in stage 2. $l_{e1i,k}$, $l_{e2i,k}$, $l_{e3i,k}$ denote three load level, they are deducted from D_{e1} , D_{e2} and D_{e3} respectively. (2-1-40)-(2-1-48) represent the maximum upper limits of load curtailment. The same as heating and cooling energy. Equation (2-3-4)-(2-3-7) represents capacity of transformer, transmission line and gas pipeline. Considering the possibility that electrical energy may be sent back to the grid, X_0 can be negative.

2.3.2 Case studies

2.3.2.1 Comparison between two-stage model and one-stage model

In this thesis, the EH system adopts a two-stage operation mode. In the period of frequent disasters, the stage before the disaster is called the first stage, and the stage when the disaster occurs is called the second stage. The two-stage operation mode refers to predicting the types of disasters and degrees of damage that may occur in the second stage and planning the operation mode of the first stage according to the goal of the lowest total cost of both stage 1 and stage 2. In the second stage, the optimization goal is based on the current actual situation. The independent variable of optimization is about the energy storage operation, including the operating state (charging or discharging) and the energy storing or releasing energy value at each moment. Other variables include the amount of electricity and natural gas purchased from the main grid and the main natural gas network, and the amount of load curtailment in the second stage.

The one-stage optimization model does not take into account the overall target problem after the two stages are coordinated. The purpose of this case study is to prove that the two-stage operating mode does have a significant effect on reducing total cost and total energy consumption compared to the one-stage optimized operating mode.

Information of basic data is shown as follows:

Table 2-1 Parameter of EH_A

ES_{max}	800 kwh	ES_{max1}	2000 kwh
CS_{max}	150 kwh	CS_{max1}	400 kwh
HS_{max}	100 kwh	HS_{max1}	200 kwh
C_l	1000 kwh	C_p	300 kwh
a_1	15 yuan/kwh	C_{CCHP_C}	250 kwh
a_2	8 yuan/kwh	C_{CCHP_H}	110 kwh
a_3	3 yuan/kwh	pdf	[0.2 0.3 0.3 0.1 0.1]

Table 2-2 Parameters of CCHP

η_{CCHP_E}	η_{CCHP_T}	$\eta_{E,IN}$	$\eta_{E,OUT}$	
0.4	0.55	0.9	0.9	
$\mu_{E,IN}$	η_C	δ_{heat}	δ_{cool}	η_{loss}
0.05	0.85	0.8	1.2	0.05

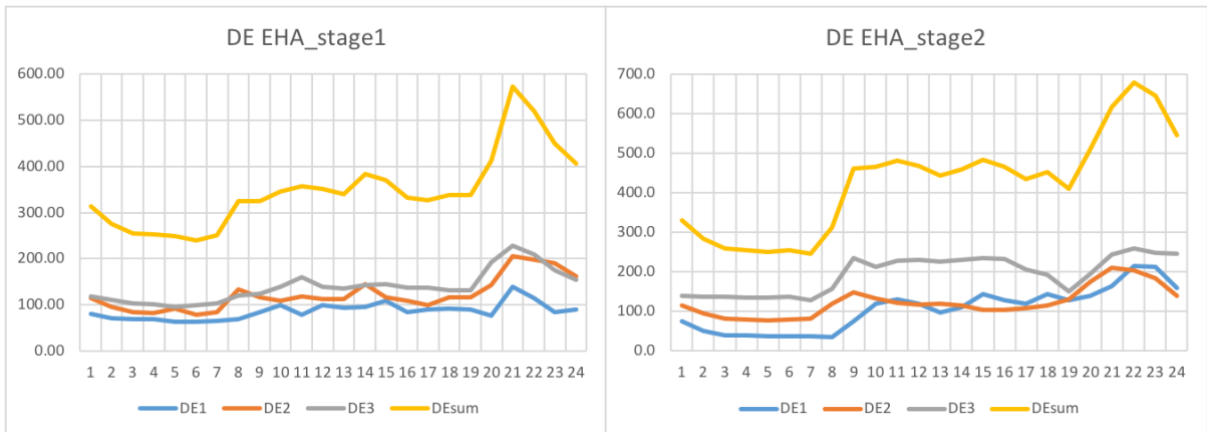

(a)

(b)

Figure 2-2 Electricity load curve of EH_A

MATLAB YALMIP toolbox was used to solve this problem. The optimization results are shown in table 2-3.

Table 2-3 Two-stage optimization mode results/yuan

C_{e1}	5483.04	C_{cut}	68799.16
C_{e2}	1574.89	C_{cut_c}	647.03
C_{g1}	1116.11	C_{cut_e}	66160.79
C_{g2}	546.62	C_{cut_h}	1991.34
Sum cost of stage 1 & 2		77519.82	

Table 2-4 Stage 1 results of one-stage optimization mode/yuan

C_{e1}	3736.43	E_0	0.00
C_{g1}	1176.95	C_0	271.69
Sum cost of stage 1	4913.38	H_0	138.91

Table 2-5 Stage 2 results of one-stage optimization mode/yuan

C_{e2}	1648.26	C_{cut}	96157.30
C_{g2}	537.50	C_{cut_c}	541.48
Sum cost of stage 2	98343.07	C_{cut_e}	93455.57
Sum cost of stage 1 & 2	103256.45	C_{cut_h}	2160.25
Δ (total value difference between 2 modes)	25736.63	Total cost increase percentage/%	24.92%



Figure 2-3 Price data

The table shows the total cost of integrated model reduced by about 25%, and load curtailment, especially electricity, was reduced sharply. Noticing that the electricity purchasing cost of integrated model in stage 1 is higher than the separated model, that is because ES must store more energy to respond to the problem of insufficient energy supply during disaster stage, but instead the demand side was affected less by the advance consideration.

In doing this case, transmission efficiency caused by different scenarios (S_E/S_G), scenario possibility (pdf), output value of different load (α_j), capacity and self-loss rate of ESS are the main factors that affect the results. When S_E/S_G include more 0 or value close to 0, which means the scenario is more serious than others, or the pdf of serious scenario, which means the serious failure has a greater possibility to happen, has been set lower, the greater the advantage of the two-stage method will be.

2.3.2.2 Comparison between model considering load priority and without considering priority

The power load shall be classified according to the requirements for power supply reliability and the degree of loss or influence caused by the interruption of power supply to the political and economic, and may be classified into level 1 load, level 2 load and level 3 load. Different levels of load have corresponding output value per kWh, that is electricity production value. The value of electricity production refers to the income that can be obtained after consuming kilowatt-hour of electricity. The value varies from a few to several tens. The determination of this value is related to the economic loss caused by a specific load being removed. The greater the electrical output value of the load of this level, the bigger the importance of multiplier a_j in this paper. Similar to the cooling and heating load.

If the load priority is not set, the load shedding will be random when the disaster strikes, and the important load curtailment may be more than the secondary load cutting, which is detrimental to the stability of the user side. After grading the load demand, the level 1 and the level 3 load will be first removed when the disaster occurs, the critical load, that is the level 1 load, will be retained to the maximum extent, and the cost of cutting the load will be minimized. The purpose of this case study is to prove that load priority setting is very helpful in minimizing the objective total cost.

The case study results are shown as follows:

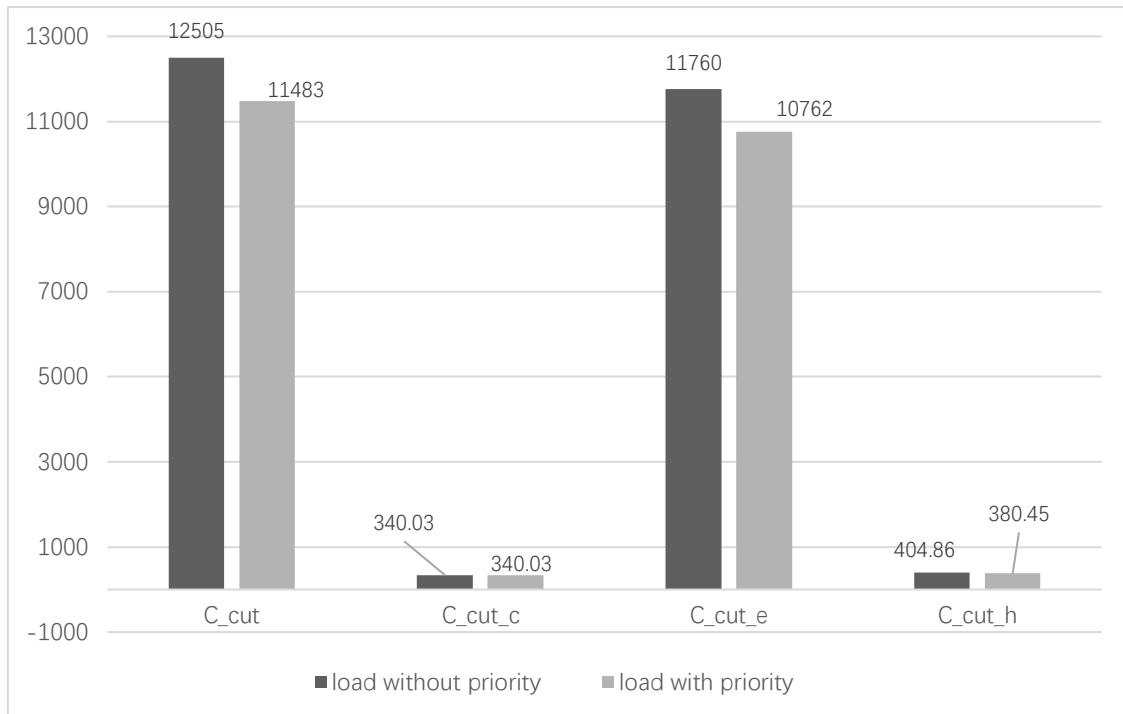

Figure 2-4 Load curtailment fees comparison

Table 2-6 Load curtailment punishing fee

load without considering priority / yuan		Load considering priority / yuan	
C_{cut}	12505	C_{cut}	11483
C_{cut_c}	340.0345	C_{cut_c}	340.0345
C_{cut_e}	11760	C_{cut_e}	10762
C_{cut_h}	404.855	C_{cut_h}	380.4476

Table 2-6 and figure 2-4 shows that after load priority setting, curtailment has been reduced obviously. Figure 2-4 and table 2-6 show that after load priority setting, the important load is retained to the maximum extent, while the unimportant load is preferentially removed.

Table 2-7 Electric load curtailment (load without considering priority)

load level	Scenario 1	Scenario 2	Scenario 3	Scenario 4	Scenario 5
1	0	72.42%	99.99%	0	58.98%
2	0	31.25%	99.99%	0	26.197%
3	0	44.8%	100%	0	38.18%
Total load shedding	0	49.62%	99.99%	0	41.19%

Table 2-8 Electric load curtailment (load considering priority)

load level	Scenario 1	Scenario 2	Scenario 3	Scenario 4	Scenario 5
1	0	56.15%	93.65%	0	32.069%
2	0	45.57%	98.47%	0	41.19%
3	0	50.73%	100%	0	58.24%
Total load shedding	0	50.8%	97.27%	0	43.22%

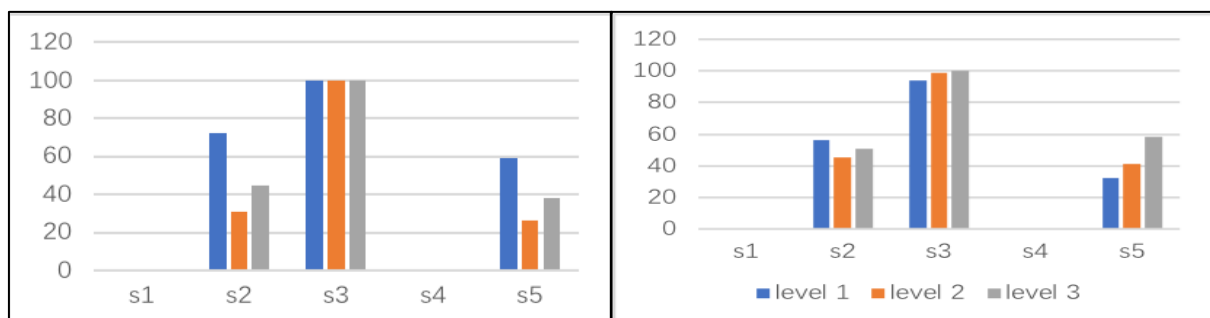

(a)

(b)

Figure 2-5 Load curtailment comparison between mode without considering load priority (a) and considering load priority (b)

Take electricity load of EH_A for example. The load curtailment was expressed as percentage of the total load of that level because during some case studies before, the absolute value of load curtailment has been proved not very accurate and representative when the important load is much larger than less important load so that the system would cut a large scale of important load while the low level load has already been curtailed to zero. Using expression of percentage will be more reasonable for the comparison.

It can be seen very clearly that in scenario 2,3 and 5, cutting rate of level 1 loads have been reduced up to about 27%, and cutting rate of level 3 loads have been increased up to 20%, but the total cutting rates don't change much. The result shows that setting load priority can significantly optimize load curtailment distribution, high level load can be supplied to the maximum extent, while low level load will be preferentially cut. The result also applies to heating and cooling loads.

Chapter 3 Multi-energy hub model

3.1 Basic structure

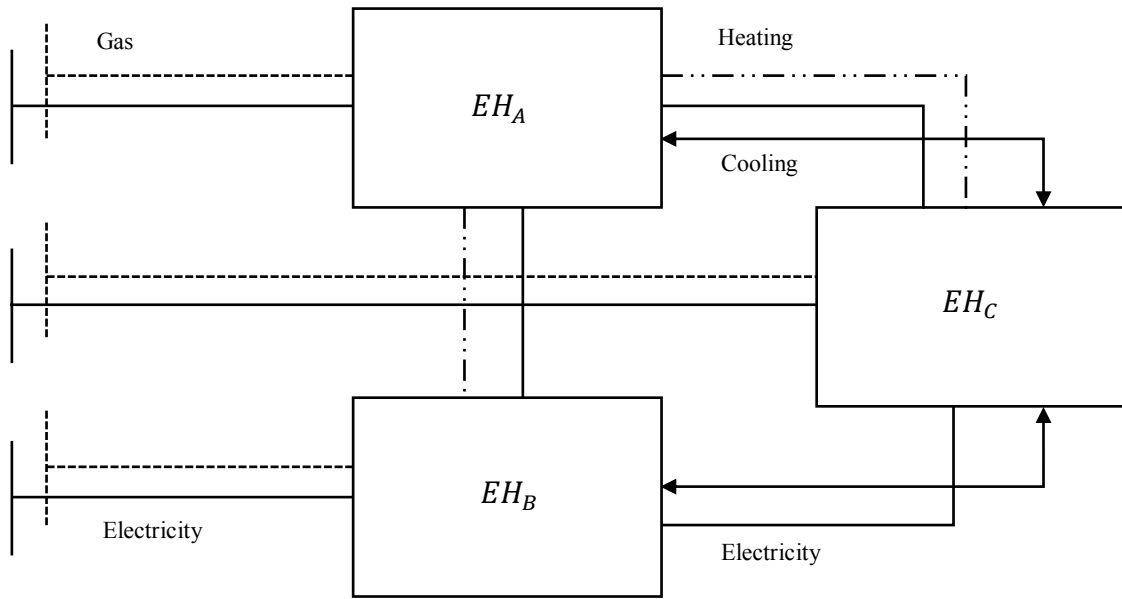

Figure 3-1 Three-energy hub system structure

Structure of three-EH system is as figure 3-1. The dotted line means the gas grid transmission pipeline, while the solid line means the electricity grid line. The double dotted line, double arrow line and solid line denotes heating, cooling and electricity exchange within the system.

In this system, electricity outputs of each EH are assumed to be transmitted and complemented between all EHs. Cooling outputs are assumed to be transmitted and complemented between EH_A and EH_C , EH_B and EH_C . Heating outputs are assumed to be transmitted and complemented between EH_A and EH_C , EH_A and EH_B . Each energy hub has

direct communication lines with the main power grid and the main natural gas network to facilitate the purchase of energy directly from the main network when necessary.

Assuming that electricity can be interconnected through different energy hubs both in stage 1 and stage 2, heating and cooling energy of EH_A , EH_B and EH_C will only be allowed to interconnect with each other in stage 2. The reason is under normal operating conditions, cooling and heating supplied by the CCHP inside EH should be sufficient and no replenishment from other EH is required. Structure within each energy hub is as same as the single energy hub model part.

3.2 Case study

3.2.1 Basic data

Table 3-1 Parameters of EH_A

ES_{max}	800 kwh	ES_{max1}	2000 kwh
CS_{max}	150 kwh	CS_{max1}	400 kwh
HS_{max}	100 kwh	HS_{max1}	200 kwh
C_l	1000 kwh	C_p	300 kwh
a_1	15 yuan/kwh	C_{CCHP_C}	250 kwh
a_2	8 yuan/kwh	C_{CCHP_H}	110 kwh
a_3	3 yuan/kwh		

pdf	[0.2 0.3 0.3 0.1 0.1]
S_E_A	$\begin{bmatrix} 0.25 & 0.2 & 0.2 & 0.2 & 0 & 0 & 0 & 0 & 0 & 0 & 0 & 0 & 0 & 0 & 0 & 0.1 & 0.15 & 0.22 & 0.25 & 0.3 & 0.4 & 1 & 1 & 1 & 1 \\ 0 & 0.1 & 0.15 & 0.26 & 0.3 & 0.4 \\ 0 & 0 & 0 & 0 & 0 & 0 & 0 & 0 & 0 & 0 & 0 & 0 & 0 & 0 & 0 & 0 & 0 & 0 & 0 & 0.1 & 0.23 & 0.3 & 0.4 & 0.45 & 0.5 \\ 0 & 0 \\ 0.8 & 0.8 & 0.8 & 0.8 & 0.8 & 0.8 & 0.4 & 0.4 & 0.2 & 0.2 & 0.1 & 0.1 & 0 & 0 & 0 & 0 & 0.2 & 0.2 & 0.3 & 0.3 & 0.6 & 0.6 & 0.7 & 0.75 \end{bmatrix}$
S_G_A	$\begin{bmatrix} 0.25 & 0.2 & 0.2 & 0.2 & 0 & 0 & 0 & 0 & 0 & 0 & 0 & 0 & 0 & 0 & 0 & 0.1 & 0.15 & 0.22 & 0.25 & 0.3 & 0.4 & 1 & 1 & 1 & 1 \\ 0 & 0.1 & 0.15 & 0.26 & 0.3 & 0.4 \\ 0 & 0 & 0 & 0 & 0 & 0 & 0 & 0 & 0 & 0 & 0 & 0 & 0 & 0 & 0 & 0 & 0 & 0 & 0 & 0.1 & 0.23 & 0.3 & 0.4 & 0.45 & 0.5 \\ 0 & 0 \\ 0.8 & 0.8 & 0.8 & 0.8 & 0.8 & 0.8 & 0.4 & 0.4 & 0.2 & 0.2 & 0.1 & 0.1 & 0 & 0 & 0 & 0 & 0.2 & 0.2 & 0.3 & 0.3 & 0.6 & 0.6 & 0.7 & 0.75 \end{bmatrix}$

Table 3-2 Parameters of EH_B

ES_{max}	1000 kwh	ES_{max1}	2500 kwh
CS_{max}	200 kwh	CS_{max1}	500 kwh
HS_{max}	150 kwh	HS_{max1}	450 kwh
C_l	1500 kwh	C_p	300 kwh
a_1	35 yuan/kwh	C_{CCHP_C}	333 kwh
a_2	15 yuan/kwh	C_{CCHP_H}	118 kwh
a_3	3 yuan/kwh		
pdf	[0.2 0.2 0.1 0.3 0.2]		
S_E_B	$\begin{bmatrix} 0.2 & 0.25 & 0.3 & 0.3 & 0.2 & 0.1 & 0 & 0 & 0 & 0 & 0.25 & 0.35 & 0.2 & 0.4 & 0.45 & 0.1 & 0.15 & 0.4 & 0.8 & 1 & 1 & 1 & 1 & 1 & 1 \\ 0 & 0 & 0 & 0 & 0 & 0.1 & 0.1 & 0 & 0 & 0 & 0 & 0 & 0 & 0.1 & 0.2 & 0.23 & 0 & 0 & 0 & 0.1 & 0.3 & 0.5 & 0.6 & 0.7 & 0.7 \\ 0 & 0 \\ 0 & 0.2 & 0.2 & 0.3 & 0.3 & 0.3 \\ 0.1 & 0.13 & 0.15 & 0.25 & 0.3 & 0.35 & 0.2 & 0.13 & 0.1 & 0.1 & 0.1 & 0.1 & 0 & 0 & 0 & 0 & 0 & 0.4 & 0.5 & 0.7 & 0.7 & 0.75 & 0.75 & 0.8 & 0.9 \end{bmatrix}$		
S_G_B	$\begin{bmatrix} 0 & 0 \\ 0 & 0 & 0.5 & 0.5 & 0.3 & 0.25 & 0 & 0 & 0.3 & 0.5 & 0.7 & 0.95 & 1 & 1 & 1 & 1 & 1 & 0.3 & 0.4 & 1 & 1 & 1 & 1 & 1 & 1 \\ 1 & 1 \\ 0 & 0 & 0 & 0.2 & 0.24 & 0.3 & 0.34 & 0 & 0 & 0 & 0 & 0 & 0 & 0 & 0 & 0 & 0 & 0.2 & 0.3 & 0.6 & 0.6 & 0.7 & 0.9 \\ 0.1 & 0.1 & 0.2 & 0.1 & 0 & 0 & 0 & 0 & 0 & 0 & 0 & 0 & 0 & 0 & 0 & 0 & 0 & 0.2 & 0.4 & 0.5 & 0.8 & 0.85 \end{bmatrix}$		

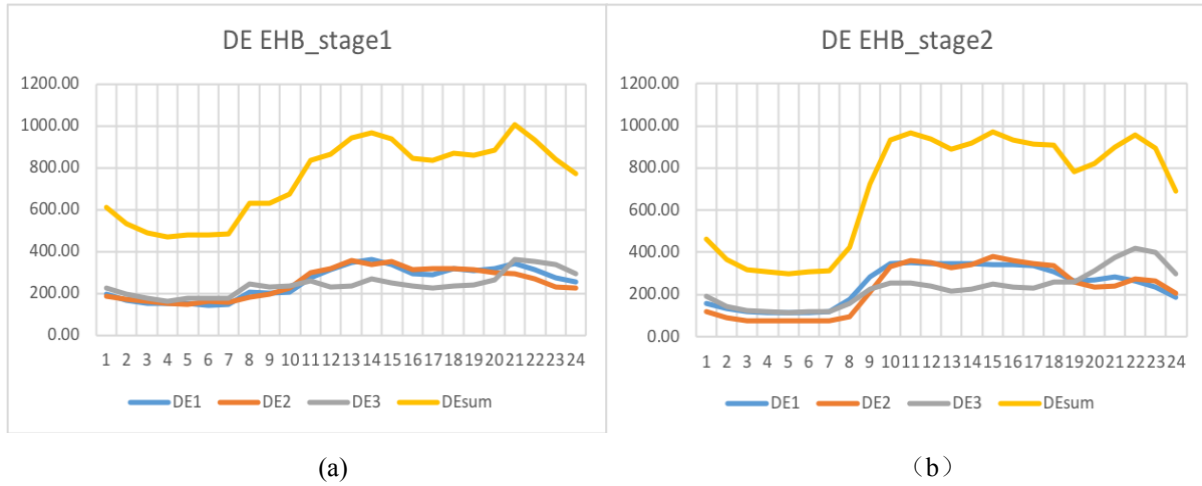

Figure 3-3 Load curve of EHB

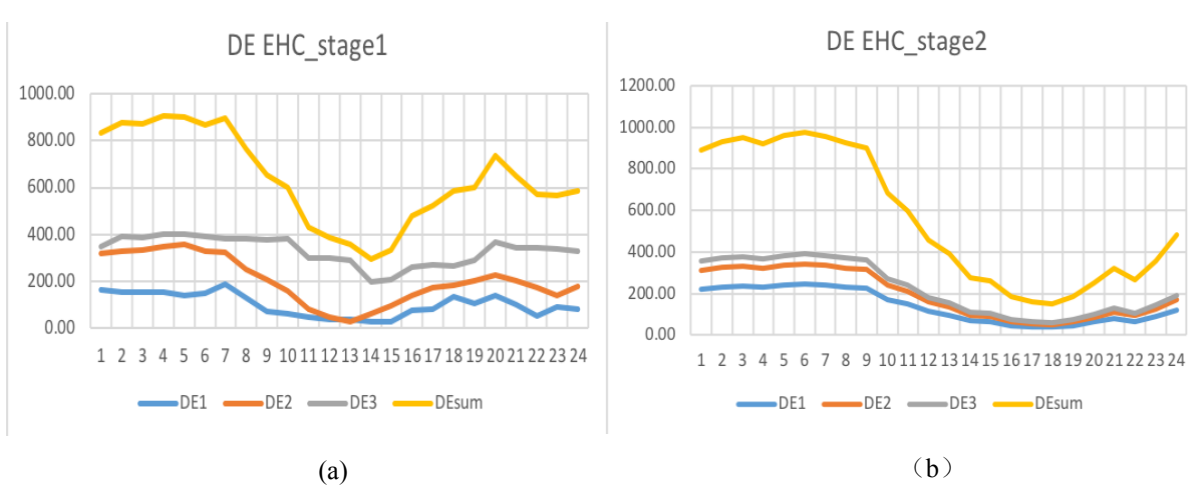

Figure 3-4 Load curve of EHC

3.2.2 Mathematical expression

Objective function:

$$f = \min\{\sum_{n \in N}(W_{ope1,n} + E(W_{cur2,n} + W_{ope2,n}))\} \quad (3-2-1)$$

Index n denotes EH's name, N represents the set of EHs included in this system.

Difference in constraints is that the transmission energy between EHs are added into the energy balance equations.

$$D_{E,n} + E_{IN,n}\eta_{E,IN} - \frac{E_{OUT,n}}{\eta_{E,OUT}} - L_{eci,n} + \sum TE_{lr} = Y_0 * CV * \eta_{CCHP_E} + X_0 \quad (3-2-2)$$

$$\left(D_{C,n} + C_{IN,n}\eta_{C,IN} - \frac{C_{OUT,n}}{\eta_{C,OUT}} - L_{cci,n} + \sum TC_{lr} \right) * \frac{1}{\delta_{cool}} + \left(D_{H,n} + H_{IN,n}\eta_{H,IN} - \frac{H_{OUT,n}}{\eta_{H,OUT}} - L_{hci,n} + \sum TH_{lr} \right) * \frac{1}{\delta_{heat}} = Y_0 * CV * \eta_{CCHP_T} \quad (3-2-3)$$

$$-C_{TLe,n} \leq TE_{lr,n} \leq C_{TLe,n} \quad (3-2-4)$$

$$-C_{TLC,n} \leq TC_{lr,n} \leq C_{TLC,n} \quad (3-2-5)$$

$$-C_{TLh,n} \leq TH_{lr,n} \leq C_{TLh,n} \quad (3-2-6)$$

Expressions (3-2-2)-(3-2-3) represent the energy balance of load nodes, TE_{lr} , TC_{lr} , TH_{lr} denote the transmission energy between different EHs, energy flow direction is from node 1 to node r , transmission line capacities are defined as $C_{TLe,n}$, $C_{TLC,n}$, $C_{TLh,n}$. Load curtailment $L_{eci,n}$ in stage 1 is set to be zero.

EHs are considered as nodes in the system, so the number of EH_A , EH_B and EH_C are 1,2 and 3 respectively. What can be easily seen in figure 2 is that electricity is shared by 3 lines, cooling energy is shared between node 1-3 and 2-3, while heating energy is shared between node 1-2 and 1-3. When natural disaster happens, ES will make an optimal operation plan in advance according to the disaster prediction situation of stage 2, if there are complementary

load curves in different EHs, energy exchange will be performed on transmission lines, which greatly reduces the dependence of EH on the external grid. By doing this, the total cost of the whole system can be relatively low on the premise of ensuring the lowest load curtailment.

3.2.3 Case study results

Use MATLAB YALMIP toolbox to solve this problem. The main work is do the comparison between model with and without coordination, and do a cost distribution.

Table 3-4 Simulation results without coordination

	EH_A	EH_B	EH_C
C_{cut}	68799.11	192770.73	128756.16
C_{cut_e}	66160.74	182220.72	108854.53
C_{cut_c}	647.03	5267.92	19438.34
C_{cut_h}	1991.34	5282.09	463.29
C_e	7057.93	18925.61	7970.14
C_{e1}	5483.04	13766.26	5748.35
C_{e2}	1574.89	5159.35	2221.79
C_g	1662.73	2892.10	4070.55
C_{g1}	1116.11	1866.73	2865.60
C_{g2}	546.62	1025.37	1204.95
Total cost of each EH	77519.77	214588.44	140796.86
Total cost of all EHs	432905.07		

Table 3-5 Simulation results with coordination

	EH_A	EH_B	EH_C
C_{cut}	39821.07	51138.36	48713.82
C_{cut_e}	39117.71	46805.36	44554.53
C_{cut_c}	256.20	2388.04	3751.72
C_{cut_h}	447.16	1944.96	407.57
C_e	10456.05	11725.82	12368.38
C_{e1}	8950.59	7864.15	7437.19
C_{e2}	1505.46	3861.68	4931.19
C_g	1720.73	2849.16	4799.47
C_{g1}	1074.01	1779.89	2879.12
C_{g2}	646.72	1069.28	1920.36
Total cost of each EH	51997.84	65713.35	65881.67
Total cost of all EHs	183592.86		

where

C_{cut} is the total load curtailment fees of EH_A , EH_B and EH_C .

$C_{cut_e}/ C_{cut_c}/ C_{cut_h}$ is the electricity, cooling and heating energy load curtailment fees of EH_A , EH_B and EH_C respectively.

C_e/ C_g is the total electricity and gas purchasing fees from main network.

C_{e1}/ C_{e2} is electricity purchasing fees in stage 1 and stage 2 respectively.

C_{g1}/ C_{g2} is natural gas purchasing fees in stage 1 and stage 2 respectively.

Result shows that the total cost of coordinated three-EH model has been reduced by 57.59% compared to the model without coordination. Each EH has saved cost by 32.92%, 69.38% and 53.21% respectively. After observation through the tables, load cutting fee reducing is the one that contributed most to the total cost saving, each EH has saved load cutting fees by 42.12%, 73.47% and 62.17% respectively.

Table 3-6 Simulation results when EH_B and EH_C operate coordinately, EH_A runs separately

	EH_A	EH_B	EH_C
C_{cut}	222917.99	140667.24	156789.06
C_{cut_e}	215905.66	126591.64	116053.95
C_{cut_c}	706.80	5490.25	40263.16
C_{cut_h}	6305.52	8585.35	471.96
C_e	6907.93	11560.77	16427.00
C_{e1}	5332.48	7999.53	11660.10
C_{e2}	1575.45	3561.23	4766.90
C_g	1896.50	2883.45	4954.96
C_{g1}	1339.21	1813.76	3278.60
C_{g2}	557.28	1069.69	1676.35
Total cost of each EH	231722.41	155111.46	178171.02
Total cost of all EHs	565004.89		

Table 3-7 Simulation results when EH_A and EH_C operate coordinately, EH_B runs separately

	EH_A	EH_B	EH_C
C_{cut}	51171.21	355197.88	156739.00
C_{cut_e}	48753.54	336362.99	140025.74
C_{cut_c}	637.80	10037.90	16428.38
C_{cut_h}	1779.87	8796.99	284.88
C_e	5624.48	19892.01	9877.27
C_{e1}	4266.35	14712.82	6069.95
C_{e2}	1358.13	5179.19	3807.32
C_g	2033.77	2857.51	5223.79
C_{g1}	1350.86	1859.17	3230.16
C_{g2}	682.91	998.35	1993.63
Total cost of each EH	58829.47	377947.40	171840.07
Total cost of all EHs	608616.94		

Table 3-8 Simulation results when EH_A and EH_B operate coordinately, EH_C runs separately

	EH_A	EH_B	EH_C
C_{cut}	101521.44	335382.81	282668.55

C_{cut_e}	98835.72	320076.55	228018.96
C_{cut_c}	710.72	10037.90	54177.64
C_{cut_h}	1974.99	5268.36	471.96
C_e	12446.94	14363.87	7785.65
C_{e1}	10899.78	9171.83	5529.43
C_{e2}	1547.16	5192.04	2256.22
C_g	1881.40	2924.86	4547.20
C_{g1}	1311.37	1830.18	3183.03
C_{g2}	570.03	1094.69	1364.17
Total cost of each EH	115849.79	352671.55	295001.40
Total cost of all EHs	763522.74		

Table 3-6, 3-7, 3-8 show the result when a single EH was separated from the system while the other two are still in the coordinated mode.

The structure of these three modes can be expressed in figure 3-5, 3-6, 3-7 below:

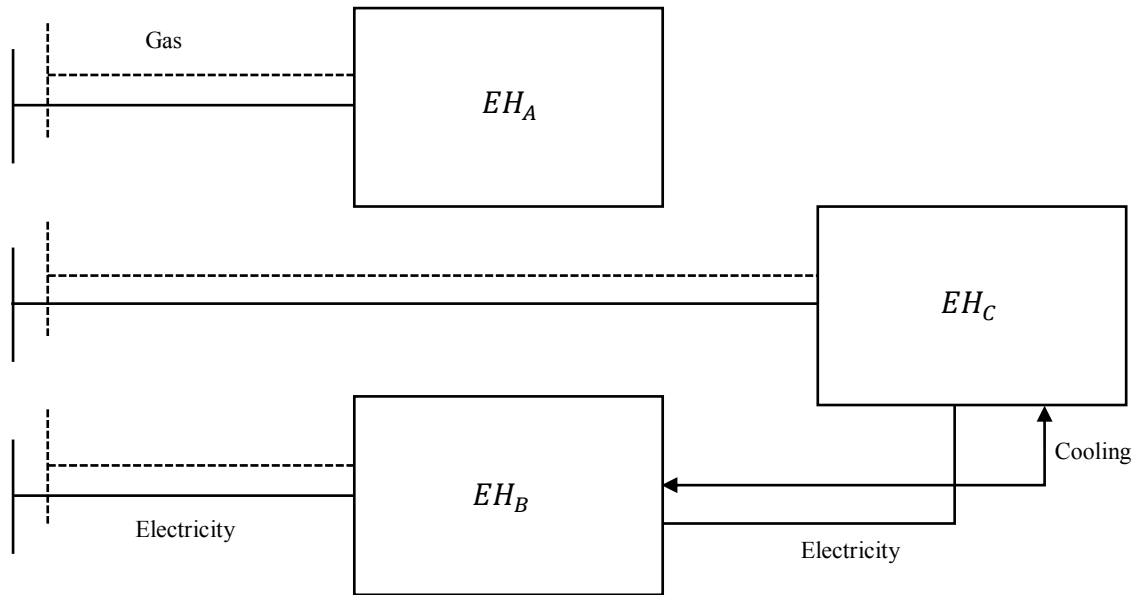

Figure 3-5 EH_B and EH_C operate coordinately, EH_A runs separately

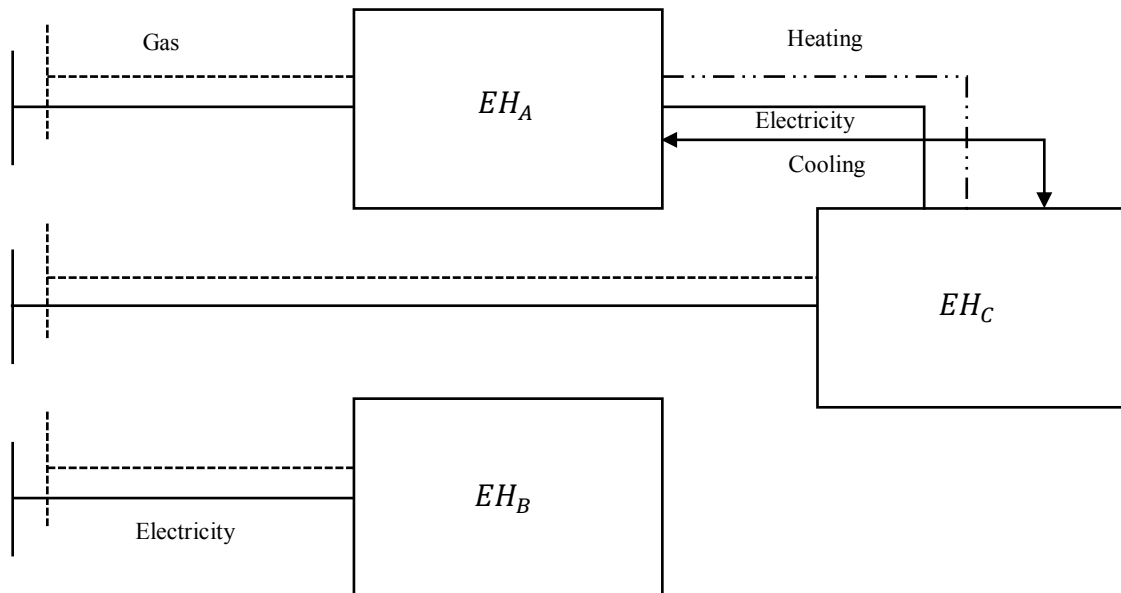

Figure 3-6 EH_A and EH_C operate coordinately, EH_B runs separately

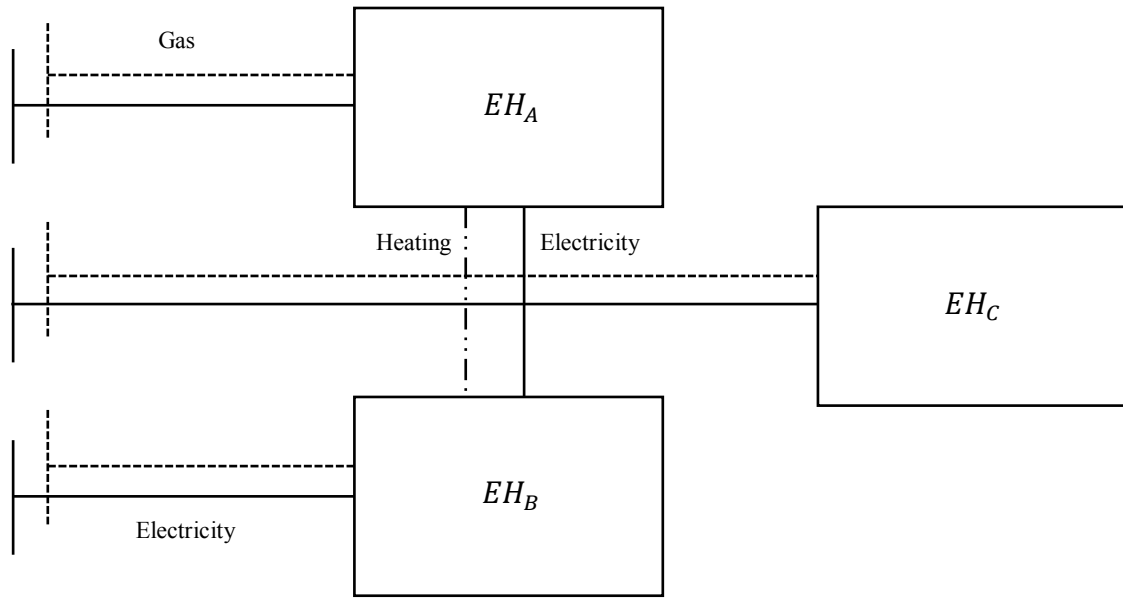

Figure 3-7 EH_A and EH_B operate coordinately, EH_C runs separately

It can be found through calculation that, the total cost of the three mode have been increased by 67.51%, 69.83% and 75.95% compared to the result of whole coordination mode.

Define C_{add} as the reducing cost between result of model with and without coordination as equation (3-2-7) shows, C_{add_i} as reducing cost between result of model with other coordination mode and whole coordination mode as equation (3-2-8) shows, in which i varies from 1 to 3, as there are 3 EHs in the system. ρ_i represents the cost reducing factor, which can express the contribution of each EH in one system as equation (3-2-9) shows. C_{co_i} represents the total cost saved due to the participation of EH i as equation (3-2-10) shows.

$$C_{add} = C_{noco} - C_{co} \quad (3-2-7)$$

$$C_{add_i} = C_{co/i} - C_{co} \quad (3-2-8)$$

$$\rho_i = \frac{C_{add_i}}{\sum_{i=1}^3 C_{add_i}} \quad (3-2-9)$$

$$C_{co_i} = C_{noco} - \rho_i * C_{add_i} \quad (3-2-10)$$

Through calculation, we have:

$$C_{add} = 249312.21 \text{ yuan} \quad (3-2-11)$$

$$\rho_A = 0.275, \rho_B = 0.307, \rho_C = 0.418 \quad (3-2-12)$$

$$C_{co_A} = 327972.36 \text{ yuan} \quad (3-2-13)$$

$$C_{co_B} = 302603.6 \text{ yuan} \quad (3-2-14)$$

$$C_{co_C} = 190315 \text{ yuan} \quad (3-2-15)$$

As the result shows, EH_C has the biggest contribution to the total cost reducing, which means when disaster happens, EH_C can give more support to other EHs and to the whole system, price of energy exchange within multi-EH system can be determined by this result to make more profits for each EH and give reasonable support to other EHs to further enhance reliability and resiliency of the system.

Chapter 4 Conclusion and future work

4.1 Conclusion

Energy hub is the key for coupling individual energy networks. It is very important for the resiliency enhancement of power system and natural gas network. In response to natural disasters, the two-stage optimized operation mode can effectively reduce the total operating costs before and after the disaster. Setting load priority results in a more optimized load curtailment distribution, unimportant load can be preferentially cut and the requirement of demand side can be satisfied better. EH can be considered as a small or big society, different EH has its unique load curve, energy storage system and distributed generator, it's feasible for several EHs to interconnect through energy both in the normal condition and disaster scenarios, and it indeed can reduce the total operation cost and load curtailment, enhance the system's resiliency and stability.

The main distribution of this research is as follows:

First, focusing on the operation cost of energy storage equipment and its self-loss cost in both two stages, as the damage degree of disaster in stage 2 will have significant influence on the decision made by operators in stage 1. The operator must reasonably distribute the system energy including energy storing or releasing value, energy purchasing or selling value and load curtailment value of stage 1, while taking into account the optimization of the objective function of stage 2.

Second, Energy remaining capacity, storing and releasing of energy storage system are considered in detail in the model, determining the purchase of electricity and gas, energy distribution, storage and load curtailment at the next moment.

Third, Load priority is set so that under the premise that the total load curtailment is the same, the most important load can be reduced the least, and the users' side requirements can be best satisfied. Each EH has different importance weight, which means energy complementation can be made between different EHs according to different characteristics of load curves.

4.2 Future Work

Future work will be the connection between EH system and power grid and gas network and do partition of the whole system. The entire power system is coupled to the natural gas system via energy hubs. In the coupled system, there are both EH domains and individual power system nodes and gas system nodes. The purpose of partitioning is to enable flexible coupling of the coupling system in the face of different types and destruction level of disasters, ensuring stable and sufficient operation in each area, while minimizing energy transmission losses within each area as well as the energy transmission value between different areas. The amount of energy transfer is as small as possible to meet the requirements of regional independent operation. Further, how the EHs could be used to enhance the energy system resiliency in the face of cyber-physical attacks will also be explored.

References

- [1] Krause T, Andersson G, Fröhlich K. (2011). Multiple-energy carriers: modeling of production, delivery, and consumption. *Proceedings of the IEEE*, 99(1), 15-27.
- [2] Yang L, Ming W, Haiming Z. (2015). Study on some key problems related to regional multi energy system based on universal flow model. *Power System Technology*, 39(8), 2230-2237.
- [3] Hongjie J, Dan W, Xiandong X. (2015). Research on some key problems related to integrated energy systems. *Automation of Electric Power Systems*, 39(7), 198-207.
- [4] Fei X, Yong M, Lei C. (2014). Combined electricity-heat operation system containing large capacity thermal energy storage. *Proceedings of the CSEE*, 34(29), 5063-5072.
- [5] Yiru D, Jian W. (2015). Modeling and optimization of integrated energy system considering synergy among energy, material and emission elements. *Journal of Tongji University: Natural Science*, 43(2), 265-272.
- [6] Xiandong X, Hongjie J, Xiaolong J. (2015). Study on hybrid heat-gas-power flow algorithm for integrated community energy system. *Proceedings of the CSEE*, 35(14), 3634-3642.
- [7] Alstone P, Gershenson D, Kammen D M. (2015). Decentralized energy systems for clean electricity access. *Nature Climate Change*, 5, 305-314.
- [8] Zhang X J, Karady G G, Ariaratnam S T. (2014). Optimal allocation of CHP-based distributed generation on urban energy distribution networks. *IEEE Transactions on Sustainable Energy*, 5(1), 246-253.
- [9] Saldarriaga C A, Hincapie R A, Salazar H. (2013). A holistic approach for planning natural gas and electricity distribution networks. *IEEE Transactions on Power Systems*, 28(4), 4052-4063.
- [10] Quelhas A, Gil E, McCalley J D. (2007). A multiperiod generalized network flow model of the U. S. integrated energy system: Part I-model description. *IEEE Transactions on Power Systems*, 22(2), 829-836.
- [11] Geidl M. (2007). Integrated modeling and optimization of multi-carrier energy systems. *Zürich: ETH*.
- [12] Favre-Perrod P. (2005). A vision of future energy networks. *2005 IEEE Power Engineering Society Inaugural Conference and Exposition in Africa*, Durban: IEEE, 13-17.
- [13] Huang A Q, Crow M L, Heydt G T. (2011). The future renewable electric energy delivery and management (FREEDM) system: the energy internet. *Proceedings of the IEEE*, 99(1), 133-148.
- [14] Huang A. (2010). FREEDM system-a vision for the future grid. *Proceedings of 2010 IEEE Power and Energy Society General Meeting*, Providence: IEEE, 1-4.

- [15] Rifkin J. (2012). The third industrial revolution: how lateral power is transforming energy, the economy, and the world. *Survival*, 2(2), 67-68.
- [16] European Commission. (2013). *Recorded conference "Mission growth: Europe at the lead of the new industrial revolution"*, Retrieved from <http://ec.europa.eu/avservices/video/player.cfm?ref=85716>.
- [17] Federal Ministry of Economics and Energy of Germany. (2013, June 26). Retrieved from <http://www.e-energy.de/en/index.php>.
- [18] Hongbin S, Qinglai G, Zhaoguang P. (2015). Energy internet: concept, architecture and frontier outlook. *Automation of Electric Power Systems*, 39(19), 1-8.
- [19] Guodong R, Yingling S. (2015). Research on the concept of energy Internet and its operation framework. *Technology Innovation and Application*, 36, 36-37.
- [20] Fang Y, Cuifen B, Yibin Z. (2015). Research on the value and implementation framework of energy internet. *Proceedings of the CSEE*, 35(14), 3495-3502.
- [21] Geidl M, Koeppl G, Favre-Perrod P. (2007). Energy Hubs for the future. *IEEE Power and Energy Magazine*, 5(1), 24-30.
- [22] Carradore L, Bignucolo F. (2008). Distributed multi-generation and application of the energy hub concept in future networks. *43rd International Universities Power Engineering Conference*, Padova: IEEE, 1-5.
- [23] Krause T, Kienzle F, Liu Y, et al. Modeling interconnected national energy systems using an energy hub approach. *2011 IEEE Trondheim Power Tech*, Trondheim: IEEE, 2011:1-7.
- [24] Chen Q, Liu D, Lin, J. (2015). Business models and market mechanisms of energy internet. *Power System Technology*, 39(11), 3047–3053.
- [25] Estrada F, Botzen L, and Tol R. (2015). Economic losses from US hurricanes consistent with an influence from climate change, *Nature Geoscience*, 8, 880–884.
- [26] National Academy of Sciences U.S.A, National Research Council. (2012). *Disaster Resilience: A National Imperative*. Washington, D.C.: The National Academies Press.
- [27] Kenward A, Raja U. (2013). Blackout: Extreme weather, climate change and power outages. Executive Office of the President. U.S.A., *Economic Benefits of Increasing Electric Grid Resilience to Weather Outages*.
- [28] Sheikhi A, Ranjbar A M, Safe F. (2011). A novel method to determine the best size of CHP for an energy hub system. *2011 2nd International Conference on Electric Power and Energy Conversion Systems (EPECS)*, Sharjah: IEEE, 1-7.
- [29] Geidl M, Andersson G. (2007). Optimal coupling of energy infrastructures. *2007 IEEE Lausanne Power Tech*. Lausanne: IEEE, 1398-1403.

- [30] Yi W, Ning Z, Chongqing K. (2015). Summary and Prospect of Research on Optimization Planning and Operation of Energy Hubs in Energy Internet. *Proceedings of the CSEE*, 35(22), 5669-5681.
- [31] Lu J, Zeng M, Zeng X, Fang Z, Yuan J. (2015). Analysis of ice-covering characteristics of China Hunan. *IEEE Trans.*, 51(3), 1997-2002.
- [32] Li M, Nian L, Jianhua Z, Lingfeng W. (2018). Real-time Rolling Horizon Energy Management for the Energy-Hub-Coordinated Prosumer Community from a Cooperative Perspective. *IEEE Transactions on Power Systems*, not been fully edited, DOI 10.1109/TPWRS.2018.2877236.
- [33] Fangze L, Longhua Y, Tao Z, Wei Z. (2018). Model ling and Optimization of Multi-energy Coupling Hub for Micro-energy Network. *Automation of Electric Power Systems*, 42(14), 91-98.
- [34] Xiaoqing X, Weimin K, Yun Y. (2012). Superstructure-based optimal planning of cogeneration systems with storage. *Proceedings of the CSEE*, 32(32), 8-14.
- [35] Xingyue L, Hongbin W. (2015). A control strategy and operation optimization of combined cooling heating and power system considering solar comprehensive utilization. *Automation of Electric Power Systems*, 39(12), 1-6.
- [36] Jiakun F, Qing Z, Xiaomeng A, Zhe C, Jinyu W. (2018). Dynamic Optimal Energy Flow in the Integrated Natural Gas and Electrical Power Systems. *IEEE Transactions on Sustainable Energy*, 9(1), 188-198.
- [37] Cong L, Mohammad S, Jianhui W. (2011). Coordinated scheduling of electricity and natural gas infrastructures with a transient model for natural gas flow. *Chaos: An Interdisciplinary Journal of Nonlinear Science*, 21(2).
- [38] Yan M, He Y, Shahidehpour M, Ai X, Li Z, Wen J. Coordinated Regional-District Operation of Integrated Energy Systems for Resilience Enhancement in Natural Disasters. *IEEE Transactions on Smart Grid*.
- [39] Ahčin P, Šikić M. (2010). Simulating demand response and energy storage in energy distribution systems. *2010 International Conference on Power System Technology, Hangzhou*, 1-7.
- [40] Zhang X, Shahidehpour M, Alabdulwahab A, Abusorrah A. (2015). Optimal Expansion Planning of Energy Hub with Multiple Energy Infrastructures. *IEEE Transactions on Smart Grid*, 6(5), 2302-2311.
- [41] Barani M, Aghaei J, Akbari M. A., Niknam T, Farahmand H, Korpås M. Optimal Partitioning of Smart Distribution Systems into Supply-Sufficient Microgrids. *IEEE Transactions on Smart Grid*.
- [42] Jingxiang Z, Huanna N, Xiaoxue Z. Island partition of distribution network with microgrid based on the energy at risk. *IET Generation, Transmission & Distribution*, 11(4), 830-837.
- [43] Chai Y, Guo L, Wang C, Zhao Z, Du X, Pan J. (2018). Network Partition and Voltage Coordination Control for Distribution Networks with High Penetration of Distributed PV Units. *IEEE Transactions on Power Systems*, 33(3), 3396-3407.