



TRAFFIC OPERATIONS ASSET MANAGEMENT SYSTEMS

**PART 2: SUMMARY OF PROCEEDINGS
FOR THE 2008 NATIONAL PEER
EXCHANGE TRAFFIC OPERATIONS ASSET
MANAGEMENT SYSTEMS (TOAMS)**

Project 08-14
July 2008

Midwest Regional University Transportation Center
College of Engineering
Department of Civil and Environmental Engineering
University of Wisconsin, Madison



Authors: Teresa M. Adams, Jason Bittner, Dadit Hidayat
University of Wisconsin-Madison

Principal Investigator: Teresa M. Adams, Ph.D.
Professor, Department of Civil and Environmental Engineering, University of Wisconsin-Madison

DISCLAIMER

This research was funded by the Midwest Regional University Transportation Center. The contents of this report reflect the views of the authors, who are responsible for the facts and the accuracy of the information presented herein. This document is disseminated under the sponsorship of the Department of Transportation, University Transportation Centers Program, in the interest of information exchange. The U.S. Government assumes no liability for the contents or use thereof. The contents do not necessarily reflect the official views of the Midwest Regional University Transportation Center, the University of Wisconsin, the Wisconsin Department of Transportation, or the USDOT's RITA at the time of publication.

The United States Government assumes no liability for its contents or use thereof. This report does not constitute a standard, specification, or regulation.

The United States Government does not endorse products or manufacturers. Trade and manufacturers names appear in this report only because they are considered essential to the object of the document.

EXHIBIT B

Technical Report Documentation Page

1. Report No. MRUTC 08-14	2. Government Accession No.	3. Recipient's Catalog No. CFDA 20.701	
4. Title and Subtitle Traffic Operations Asset Management Systems Part 2: Summary of Proceedings	5. Report Date July 2008		6. Performing Organization Code
	7. Author/s Teresa M. Adams, Jason Bittner, Dadit Hidayat		
9. Performing Organization Name and Address Midwest Regional University Transportation Center University of Wisconsin-Madison 1415 Engineering Drive, Madison, WI 53706	8. Performing Organization Report No. MRUTC 08-14		
	10. Work Unit No. (TRAIS)		
12. Sponsoring Organization Name and Address Wisconsin Department of Transportation Hill Farms State Transportation Building 4802 Sheboygan Avenue Madison, WI 53707	11. Contract or Grant No. 0092-08-35		
	13. Type of Report and Period Covered Final Report [11/20/07 – 9/30/08]		
14. Sponsoring Agency Code			
15. Supplementary Notes Project completed for the Midwest Regional University Transportation Center with support from the Wisconsin Department of Transportation.			
16. Abstract In April 2008, 25 people—from 10 states DOTs, AASHTO, and the University of Wisconsin at Madison—gathered at the Statewide Traffic Operations Center (STOC), in Milwaukee, Wisconsin, for the 2008 National Peer Exchange on Traffic Operations Asset Management System (TOAMS). Participants successfully worked together to create—and to lay the groundwork for creating: (1) a network of peers who can share information and ideas on TOAMS; (2) understanding of current TOAMS practices; (3) articulation of a national agenda and next steps for TOAMS. A common definition is used by participants to standardize the discussions. On one hand, Traffic Operations assets (TOA) are defined as transportation equipment infrastructure that is active and more dynamic than traditional transportation facilities. On the other hand, Traffic Operations Asset Management (TOAM) is a systematic process of maintaining, upgrading, and operating physical assets of ITS devices and other traffic operations hardware and systems. The following recommendations emerged at the end of the peer exchange to encourage the effective application of TOAMS. <ol style="list-style-type: none"> 1. A national standard for technological level and configuration, which addresses strategies for performance changes and incorporating technological trends, including concerns of TOA compatibility. 2. A national standard for maintenance, which addresses life-span and life-cycle costs for traffic operations and operational performance. 3. An AASHTO guide to traffic operations, which will include: <ul style="list-style-type: none"> – Scan and synthesis of practices including contracting approaches and management skills – Self assessment and/or peer review on processes or programs conducted – Set of guidance “brochures” 			
17. Key Words traffic operations, asset management, obsolescence planning, software development, maintenance contracting	18. Distribution Statement No restrictions. This report is available through the Transportation Research Information Services of the National Transportation Library.		
19. Security Classification (of this report) Unclassified	20. Security Classification (of this page) Unclassified	21. No. Of Pages 100	22. Price -0-

Form DOT F 1700.7 (8-72)

Reproduction of form and completed page is authorized.

TABLE OF CONTENTS

EXECUTIVE SUMMARY	1
Definition of TOAMS.....	1
Current Practices on TOAMS.....	1
Recommendations.....	2
The 2008 National Peer Exchange on TOAMS Planning Committee.....	3
1. INTRODUCTION	4
Project Overview	4
2. WELCOME AND OVERVIEW	5
3. RESULTS OF TOAMS SURVEY OF STATE AGENCIES	6
4. STATE EXPERIENCES AND EXPECTATIONS	8
5. CASE STUDIES	9
Michigan Department of Transportation (MDOT).....	9
Oregon Department of Transportation (ODOT).....	11
Colorado Department of Transportation (CDOT)	12
Virginia Department of Transportation (VDOT).....	13
6. GAPS IDENTIFICATION AND NEEDS ASSESSMENT	14
Obsolescence Planning	16
Software Systems.....	19
Maintenance Contracting and Labor Expertise.....	20
7. INVESTMENT STRATEGIES	22
8. FINDINGS AND RECOMMENDATIONS	23
Findings.....	23
Recommendations.....	24
9. ACKNOWLEDGEMENTS	25

LIST OF APPENDICES

- Appendix 1 Agenda
- Appendix 2 Participant biographies
- Appendix 3 Breakout resource sheets
- Appendix 4 Survey questionnaire
- Appendix 5 Presentation of survey result; Teresa M Adams
- Appendix 6 Case Study Michigan Department of Transportation; Greg Krueger
- Appendix 7 Case Study Oregon Department of Transportation; Galen McGill
- Appendix 8 Case Study Colorado Department of Transportation; Ken De Pinto
- Appendix 9 Case Study Virginia Department of Transportation; Jeff Price
- Appendix 10 Presentation: Obsolescence; Teresa M. Adams
- Appendix 11 Presentation: Maintenance Contracting; Felix Zambrano
- Appendix 12 Summary Presentation for Peer Exchange

LIST OF FIGURES

- Figure 1 Room 311A-B Statewide Traffic Operations Center
- Figure 2 Geographic Distribution of Survey Respondents
- Figure 3 Geographic Distribution of Peer Exchange Participants
- Figure 4 General Planning Framework
- Figure 5 Traffic Operations Life Cycle
- Figure 6 System Engineering “V” Diagram
- Figure 7 Groups interaction within TOAMS activities

LIST OF ABBREVIATIONS

AASHTO	American Association of State Highway and Transportation Officials
Caltrans	California Department of Transportation
CCTV	Closed-Circuit Television
CDOT	Colorado Department of Transportation
DOF	Department of Finance
DOT	Department of Transportation
FAA	Federal Aviation Administration
FHWA	Federal Highway Administration
ID	Identification
IMMS	Integrated Maintenance Management System
IT	Information Technology
ITS	Intelligent Transportation System
LOS	Level of Service
MDOT	Michigan Department of Transportation
MRUTC	Midwest Regional University Transportation Center
ODOT	Oregon Department of Transportation
OS	Operating System
PBF	Project Budget Forecaster
RWIS	Road Weather Information System
STOC	Statewide Traffic Operations Center
TMC	Traffic Management Center
TOA	Traffic Operations Asset
TOAM	Traffic Operations Asset Management
TOAMS	Traffic Operations Asset Management Systems
TOSNET	Traffic Operations System Networks
VDOT	Virginia Department of Transportation
VMS	Variable Message Sign
WAN	Wide Area Network
WisDOT	Wisconsin Department of Transportation

EXECUTIVE SUMMARY

In April 2008, 25 people—from 10 states DOTs, AASHTO, and the University of Wisconsin at Madison—gathered at the Statewide Traffic Operations Center (STOC), in Milwaukee, Wisconsin, for the 2008 National Peer Exchange on Traffic Operations Asset Management System (TOAMS). Participants successfully worked together to create—and to lay the groundwork for creating—the following:

- A network of peers who can share information and ideas on TOAMS
- Understanding of current TOAMS practices
- Articulation of a national agenda and next steps for TOAMS

Definition of TOAMS

The TOAMS Peer Exchange participants used a common definition to standardize the discussions. Traffic Operations assets (TOA) are defined as transportation equipment infrastructure that is active and more dynamic than traditional transportation facilities. Unlike pavement and bridge infrastructures, TOA—such as signs, signals, and ITS devices—respond and control current traffic conditions. The concept involves tangible and intangible components—for example communication links, networks, servers, fiber optics, data, and software versions—that require a different set of technical expertise.

Traffic Operations Asset Management (TOAM) is therefore a systematic process of maintaining, upgrading, and operating physical assets of ITS devices and other traffic operations hardware and systems. This system management combines a number of approaches (engineering, business management, and economic) and the latest computer-aided technology.

Current Practices on TOAMS

The peer exchange offered opportunities to learn about many different states' practices on TOAMS. From a *survey* of state agency accomplished before the peer exchange, a number of *teleconferences* for peer exchange planning, as well as *conversation* throughout the peer exchange, the peer exchange group discovered how heavily the adoption of asset management principles on construction and maintenance of pavement

and bridges influence TOAMS implementation. This influence, however, led to a number of critical issues related to the effectiveness of the varied TOA. While a number of issues were addressed and future agendas were suggested during the peer exchange, the question of how these concerns would foster a more efficient planning process, *especially when requesting the maintenance budget for TOA*, remained unclear.

States asked questions and shared successes around several key themes:

- *Connecting investment and performance.* How can we best communicate the connection between dollars spent and traffic operations performance? How can we address issues of life expectancy in TOA? Can we establish a minimum LOS for TOA? Can maintenance ensure system reliability?
- *Improving planning process.* What time horizon is suitable for TOAMS? How can ITS and IT groups collaborate in TOAMS? How can we address concerns of data stewardship in a comprehensive plan?
- *Promoting public-private partnership.* How can we promote partnership between public and private sectors? Can industries be leveraged to address compatibility issues?

Recommendations

Peer exchange participants developed the following recommendations to encourage the effective application of TOAMS.

1. *A national standard for technological level and configuration.* This recommendation addresses strategies for performance changes and incorporating technological trends, including concerns of TOA compatibility. By following this recommendation, it is expected that industries can be leveraged to collaborate during production of devices or systems. Possible advancement of technology somewhat slows the implementation of new technologies and hampers standardization, however, it is thought that a national standard will help ensure more effective planning processes, leading to more predictable advancements of technology.

2. *A national standard for maintenance.* This recommendation addresses life-span and life-cycle costs for traffic operations and operational performance. It is much related to the establishment of a historical data on TOA replacement and a minimum level of service (LOS) of TOA. These establishments will help ensure more effective decision making processes in TOA maintenance.
3. *An AASHTO guide to traffic operations.* From a perspective of DOT officials it is helpful to have a single comprehensive TOAMS synthesis that can be used in an executive decision environment as a tool for traffic operations. This mainly concerns the number of research reports available, to the point that DOT officials often feel overwhelmed. The guide will include:
 - Scan and synthesis of practices including contracting approaches and management skills
 - Self assessment and/or peer review on processes or programs conducted
 - Set of guidance “brochures”

The 2008 National Peer Exchange on TOAMS Planning Committee

Teresa Adams, University of Wisconsin-Madison

Dean Beekman, Wisconsin Department of Transportation

Jason Bittner, University of Wisconsin-Madison

Scott Bush, Wisconsin Department of Transportation

John Corbin, Wisconsin Department of Transportation

Douglas Dembowski, Wisconsin Department of Transportation

Stacey Glass, Alabama Department of Transportation

Gregory Krueger, Michigan Department of Transportation

Galen McGill, Wisconsin Department of Transportation

Charles Meyer, American Association of State Highway and Transportation Officials

Jeff Price, Virginia Department of Transportation

1. INTRODUCTION

The 2008 National Peer Exchange on Traffic Operations Asset Management Systems (TOAMS) was held at the Statewide Traffic Operations Center (STOC), Milwaukee Intermodal Station, in Milwaukee, Wisconsin, on April 21-22, 2008. This document is the official proceedings of the peer exchange, containing all materials presented and discussed during the event. In general, the document is organized chronologically during the two day event.

Figure 1 Room 311A-B Statewide Traffic Operations Center



Source: Dadit Hidayat

Project Overview

Asset management principles have been increasingly adopted by transportation agencies to identify various investment strategies and optimize the expenditure of public funds. A large percentage of transportation budgets are targeted toward the construction and maintenance of pavements and bridges. Based on this financial commitment, management systems for pavements and bridges have been developed and widely adopted throughout the United States and elsewhere.

To improve the safety and efficiency of transportation systems, public agencies are striving to enhance the operations components of their roadway networks. States have deployed emerging Intelligent Transportation Systems (ITS) and other traffic operation technologies and now recognize the need for up-to-date asset management tools and strategies. Management systems for transportation operations, though, have not been

developed or implemented as extensively as management systems for pavements and bridges.

The scope of the project includes an assessment of current asset management systems for operations infrastructure including ITS, traffic signalization, and associated network and information architecture. The research effort brings together transportation professionals to discuss and advance the state of the practice for traffic operations asset management. The project will culminate with a recommendation of concepts leading to development of a next generation Traffic Operations Asset Management System (TOAMS). The information will be used to formulate a phase 2 proposal to create and administer a multi-state pooled-fund pilot of next generation TOAMS.

2. WELCOME AND OVERVIEW

John Corbin, Wisconsin Department of Transportation's (WisDOT's) State Traffic Engineer, welcomed all the participants. He also thanked Kelly Langer, WisDOT's System Operations and Electrical Engineering Section Manager, as the host of the peer exchange at the Statewide Traffic Operations Center (STOC), in Milwaukee. Corbin illustrated his initial ideas about this project, ultimately hoping to have "better information in what is involved in operating and maintaining, particularly, traffic operations infrastructure." Sign inventory and maintenance, and a growing relationship between the public and private sectors were among the major areas emphasized. He detailed the project during the AASHTO Subcommittee on Maintenance and Subcommittee on Systems Operation and Management (SSOM) meeting (Madison, WI July, 15-19, 2007). At the July 2007 meeting, the project was broadened to capture immediate issues currently present in traffic operations infrastructure maintenance. Two central questions become the core ideas of the peer exchange and related research efforts:

- What framework makes TOAMS unique?
- What needs to be done at the national level to support effective TOAMS?

Thus, the 2008 National Peer Exchange attempted to answer core questions through discussions on:

- asset management areas related to freeway operations

- the state of the practice
- programs and systems to best maintain and operate traffic operations devices
- a framework for evaluating alternative concepts and partnerships needed to maintain and operate technical systems

Jason Bittner, Deputy Director of Midwest Regional University Transportation Center (MRUTC), University of Wisconsin-Madison, delivered a project overview and illustrated the format of the peer exchange. He indicated that all materials, discussions, and summary will be documented in two versions, a document introducing the summary and a PowerPoint presentation (filename.PPT), both distributed to all participants. The PowerPoint presentation is expected to be a tool for participants who are interested in communicating with other peers about the peer exchange program and development of maintenance systems.

3. RESULTS OF TOAMS SURVEY OF STATE AGENCIES

Teresa Adams, Principal Investigator for TOAMS project, Director of MRUTC, and Professor of Civil and Environmental Engineering at the UW-Madison, presented results of a survey on the state of the practice. The complete survey is included in the appendix #4. She also pointed out that the survey was further developed as part of a student project activity of the Department of Civil and Environmental Engineering, UW-Madison. Figure 2 shows geographic distribution of survey respondents. Major observations generated from the survey are:

- *Assets and Systems.* The survey indicated that all responding state transportation agencies manage closed-circuit television (CCTV) cameras and road weather information systems (RWIS). The survey also revealed that most of state transportation agencies manage pavement sensors, loop detectors, variable message sign (VMS) controllers, and signal system. In addition, only a few state transportation agencies managed Automated Crash Notification Systems.
- *Formal Procedures.* On the benefits of implementing formal procedures for TOAMS, state transportation agencies indicated that these procedures were needed for estimating personal needs, managing maintenance records, assessing

system deficiencies, life cycle cost analysis, performance monitoring, and managing the spare parts inventory.

- *Data Inventory.* Five types of inventory data were asked, whether state transportation agencies keep inventory data on their traffic operations assets:
 - characteristics/capabilities
 - maintenance requirements
 - maintenance cost history
 - repair/failure history
 - age/condition

The survey suggested that less than a half of the state transportation agencies keep these inventory data on their traffic operations assets.

- *Strategy on Maintenance.* The survey revealed that corrective maintenance type of strategies was commonly used by state transportation agencies, rather than preventive, inspection, or replacement strategies.
- *Assessment Method.* The survey showed that the functioning condition of traffic operations assets was mostly assessed through system monitoring, rather than field inspection or customer complaints.
- *Operational Issues.* State transportation agencies indicated a number of operational issues associated with TOAMS. Most of these operational issues were associated with conducting training to enhance technical maintenance skills, improving contractor responsiveness, reducing repair or replacement costs, repairing/replacing equipment, and standardizing components.
- *System Initiatives.* State transportation agencies also indicated that system initiatives should address issues of expanding system capabilities, coordinating agencies across jurisdiction, and adjusting/upgrading existing infrastructure system.

Figure 2 Geographic Distribution of Survey Respondents



Figure 3 Geographic Distribution of Peer Exchange Participants



4. STATE EXPERIENCES AND EXPECTATIONS

This session was dedicated to hearing participant experiences and expectations from the peer exchange; Figure 3 shows geographic distribution of peer exchange participants.

This information was used to direct discussions during the peer exchange by addressing these issues. Some of the expectations included:

- How to include Intelligent Transportation Systems (ITS) or traffic operations in the asset management program, including types of assets in the inventory, matrix integration in the business application, and how to use this information in planning process?
- What system or data requirements are needed in order to integrate operations and maintenance in a single interface?
- What organizational or policy issues occurred in the field?
- How can traffic operations performance measures translate into budget allocation?
- How to mitigate conflicts between ITS and planning processes as related to funding allocation for deployment; what innovations can be implemented in optimizing traffic operations performance?
- How do we know that the traffic operations assets we have deployed are in good condition and fully functional?
- What components should be included and what improvement can be made in traffic operations maintenance contracting? (A state representative indicated using the same maintenance contracting strategy for the last 8 years.)

- How asset management is implemented in the traffic operations field; some examples being: getting credible information from asset management, storing data analysis, and making innovations in traffic operations from a perspective of asset management?
- How to change the state legislature, DOT officials, and/or others' mindset in justifying what is needed in traffic operations asset management? (namely, state legislatures, DOT officials, etc.)
- How to build a strong commitment between the operations group and the maintenance group?
- How to address an effective balance between in-house staff and contracted staff?
- What tools can be used to identify trade-offs in traffic operations between dispatching maintenance and life cycle collection data?

5. CASE STUDIES

The four case studies from different states were presented in the peer exchange. They are from Michigan Department of Transportation (MDOT), the Oregon Department of Transportation (ODOT), the Virginia Department of Transportation (VDOT), and the Colorado Department of Transportation (CDOT). Briefs about their presentations are highlighted below, while the PowerPoint presentations are included in the appendix #6-9.

Michigan Department of Transportation (MDOT)

Greg Krueger, Program Manager for the statewide ITS program, demonstrated for the first time, publicly, the Program Budget Forecaster System (PBF). MDOT recently implemented the architecture of ITS statewide. The plan featured software created to track the costs of the initial construction, and more importantly the future costs associated with operations and maintenance. By including all of the projected costs for the entire state system, the PBF can graph the projected costs and the projected budget, both of which are scaled to include inflation and interest. Ideally, this software would allow for problems with the budget to be identified early on so that changes could be made to

balance the budget. This program is still brand new, so it was stressed that improvements will be implemented before this system is put into use.

Using the PBF would assist all DOTs to recognize ITS budget issues well in advance, as stated above. The simulation of projected cost gives a numerical and graphical representation showing the relationship between future planned expenditures and the budget received. Krueger added that this tool will be a good check when planning future projects as it will show funds available after necessary maintenance activities using this system are completed. In addition, assigning crews to carryout each project and assigning an ID tag to consolidate all possible ITS maintenance needs in one program are being added to the PBF tool.

This system is not complete, and therefore has room for improvement. However, since it has never been tested, the problems are not completely identified. From the discussion, one problem suggested itself varient terminology used in the software; for example PBF's "System Manager" refers to the ITS inspector not the construction manager.

Selected Questions & Answers

Q: Do you have a model you based on when designing this tool?

A: Michigan pulled a lot of information from the FHWA cost tracking tool. But the cost trackin tool was only designed for tracking maintenance cost, such as preventive maintenance and cleaning camera booms. This tool was not designed for heavy maintenance or replacement. In addition to maintenance cost, the PBF tool manages replacement cost.

Q: Technological cost is cheaper as time goes by, are you seeing this in your PBF tool?

A: Yes and No. Yes the cost will go down, but no it is not considered in this PBF tool. Despite the *actual* average cost will be about the same, the new technology will have more features and more advantages we can take from.

Oregon Department of Transportation (ODOT)

Galen McGill, ITS Manager, discussed his role in tracking the cost and repair of operations assets. McGill noted the common inability to shift funds between assigned uses such as bridge construction or bridge preservation, so the need for a planned budget is essential. A tool developed to solve this problem came from *Micromain XM*TM, originally designed as facility management software. Purchasing this software included the source code, which was modified to fit the specific needs of the state. *Micromain XM* tracks information on every location of ITS assets and the maintenance history. Also included are worker time info and preventative maintenance analysis.

Using *Micromain XM* enables DOTs to better track employee time on each assignment. Built into the system are easy plug-ins for assigning parts used and labor time for each site. This helps organize labor time when filling out time sheets and also increases accountability. Another feature of this program that can be emulated is the mobility. *Micromain XM* is not only available on the web from any computer, but also can be accessed from pocket PCs using a free application. This tracks, in real time, the repairs being made and reduces paper forms. A final benefit of this software is the ability to see real time backlog status.

The *Micromain XM* system is currently limited to ITS operation and maintenance. While there are talks of expanding the software to all traffic signals, the program does not have the same details and specifications the current traffic signal database contains. This is an area that will likely be pursued to tie the systems together. Another improvement will be to program the system to send reminders regarding preventative maintenance.

Selected Questions & Answers

Q: For this kind of customized software, do you have problems in updating or upgrading the software?

A: It is an issue Oregon will need to think about. At this point, Oregon has not needed to update or to upgrade the customized software. All customization steps are well documented, which will be used in doing the same customization to the newer version of the software.

Q: Do you have to customize the software separately for a pocket pc version and for a laptop version?

A: There are various levels of customization. Oregon customized the system database, instead of customizing the software to meet the tools (pocket pc, laptop, or desktop).

Colorado Department of Transportation (CDOT)

Ken DePinto, ITS Branch Manager, discussed the current use of ITS in Colorado. The newly developed 511 traveler information system was highlighted for having a 400% increase in annual call volume. The 511 system compiles travel information, allowing travelers to make more informed decisions when choosing a route, which helps with overall system efficiency. Also mentioned were the various ITS devices used to give better choices to the user, which is made possible by the connection of data with web sites. The maintenance system is not well connected and documented, but it consists of seven workers. By July 2008, they aim to have nine workers on the project.

One common element that emerged from the presentation is the notion that trip times and traffic volume to the users is invaluable. The advantages of using ramp metering in Colorado, providing accurate, were well documented in the presentation, showing 10-30% improvements in travel time, average speed, and volume. A longer study with more pronounced results was performed on the Eisenhower Johnson Tunnel, West of Denver, Colorado, showing 20% improvement by using traveler information and doing preventative maintenance during a set two weeks every year.

Colorado is however challenged with some common activities related to the use and maintenance of ITS. First, De Pinto indicated that there is no way to track maintenance completed and total hours used. Anecdotally, maintenance workers claim to have more work than they can handle, but this is not documented. De Pinto also added, in a state with highly variable weather and road types, use of the 511 system is growing rapidly and will soon approach the capacity limitations, leading to a new debate on software systems and constraints. Second, the lack of a database with all of the ITS equipment available makes assessing the systems needs difficult.

Selected Questions & Answers

Q: Does your SAP system produce a map showing the exact location of devices or segment of highway need for maintenance?

A: No, it doesn't. The Colorado state highway patrol will provide information on specific location of devices need for maintenance. So, there is a chance for confusion when identifying the location.

Virginia Department of Transportation (VDOT)

Jeff Price, Assistant Director of Operations Planning, presented his economist viewpoint of the practices of asset management in Virginia. Virginia, having the third largest road system in the country, has developed a schedule and performance based approach to traffic operations maintenance. This has translated into software management, but the regions operate on different systems such as Integrated Maintenance Management System (IMMS) and *MicroMain XT*. Virginia has adapted to the challenge of accommodating the largest naval base in the country by operating bridges that allow large ship passage. Also, to aid with hurricane evacuation, the interstate system has been fitted to allow for all lanes to travel away from the ocean, which is heavily reliant on ITS.

VDOT has developed several systems. One of these is the inventory system, which geo-references all ITS components for tracking. This system also bar codes ITS units to make event tracking and maintenance easier. The repair data and maintenance is all tracked in a database to determine unit costs and replacement. This system allows for an easy way to track preventative maintenance and create a schedule. Another useful feature is the ability to put priority of the maintenance needs in the system, giving a timeline for when the task needs to be finished. This inventory system can be used to compile data and create an effective repair schedule, including creating a hierarchy of needs and an order of importance.

There are some challenges that VDOT faces, the largest of which is statewide unity on asset management. While each region is able to track maintenance and inventory, the software used for each is different. These differences create compatibility issues and makes determining statewide needs cumbersome. The use of preventive maintenance is slowly gathering attention as the old system of "fixing only what is

broken” holds. Finally, Price noted that an accepted method of using benefit to cost ratios to determine outsourcing and best options is not fully operational yet.

Selected Questions & Answers

Q: What index do you use for cost estimation?

A: Virginia used the Producer Price Index (PPI) for street highway construction, with zero labor statistics. There is another index for facility maintenance. But the problem is it includes building, which is not as relevant to highway industries.

Q: What types of database you use in this system?

A: Virginia built both transactional and archival in a single database. One of the problems is now the database becomes more transactional database as it stores every transaction activities.

6. GAPS IDENTIFICATION AND NEEDS ASSESSMENT

This section summarizes discussions held during the gaps identification and needs assessment session on Tuesday April 22, the second day of the peer exchange. The objective of the session was to share some of the thoughts which emerged during the three breakout sessions (obsolescence planning, software systems, and maintenance contracting/labor expertise) with other participants, and to identify gaps as well as to assess needs for the implementation of TOAMS. John Corbin led the session by introducing a simplified illustration from planning levels to operations levels in state transportation agencies (Figure 4). Corbin emphasized the current challenge for traffic operations in interpreting a short range transportation plan (SRTP; 5-8 years plan) into statewide services.

Figure 4 General Planning Framework

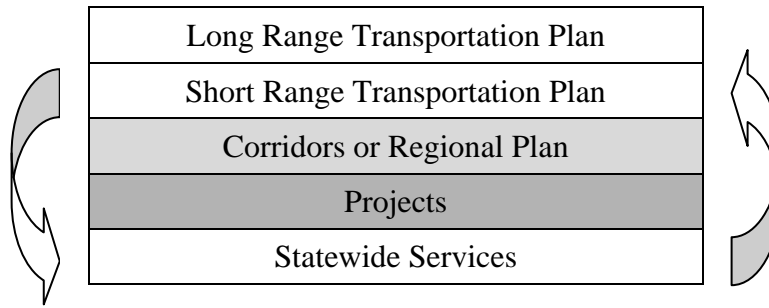

Furthermore, Corbin offered a second illustration about traffic operations life cycle. One of the concerns during the discussion was how the unique characteristics of traffic operations problems can be translated into life cycle processes. Furthermore, how can these unique characteristics identify a traffic operations life cycle from, for example, a bridge life cycle? During the session, one of participants suggested to review system engineering “V” diagram from Federal Highway Administration (FHWA) in Figure 6, and to consider overlapping the diagram with the traffic operations life cycle in Figure 5.

Figure 5 Traffic Operations Life Cycle

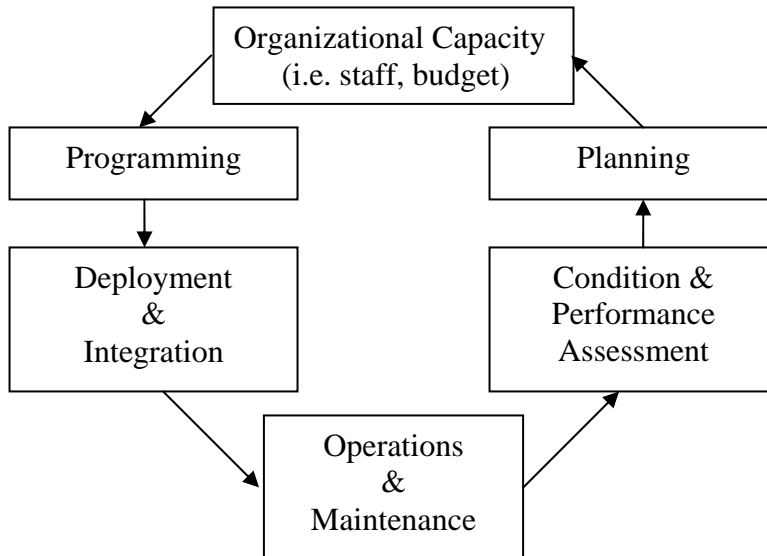
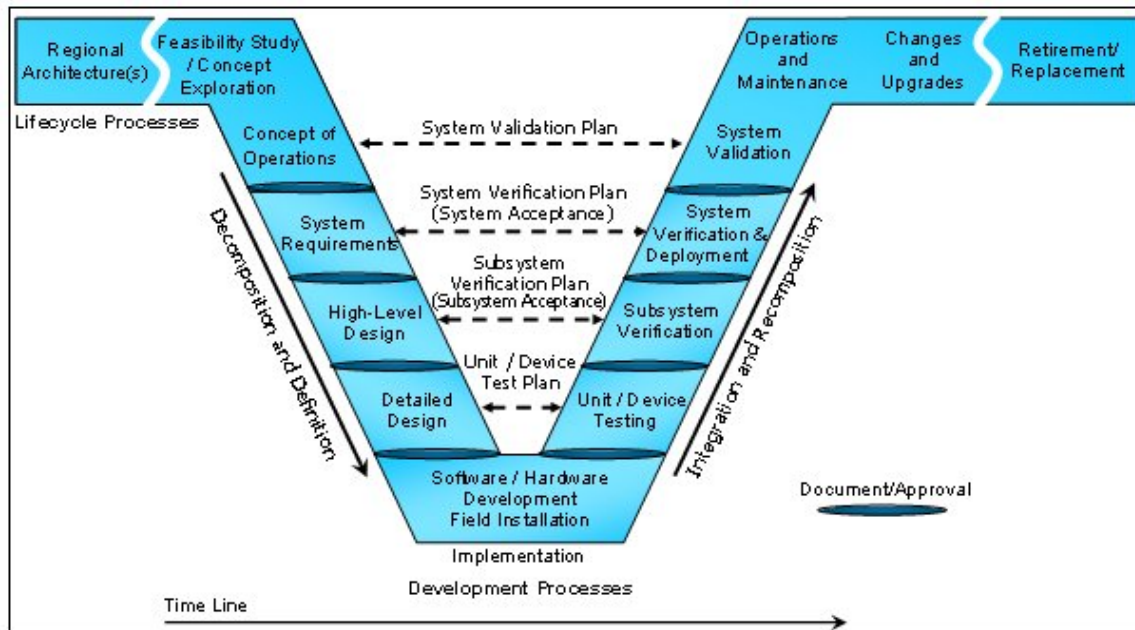

Figure 6 System Engineering “V” Diagram



Source: Office of Operations, FHWA

In the following sections, three central areas of the session are summarized. These sections capture discussions during the breakout sessions, with additional from the gaps identification and needs assessment session.

Obsolescence Planning

Teresa Adams started an obsolescence planning breakout session with a presentation based on previous work by Andrew Lemer entitled “Infrastructure Obsolescence and Design Service Life” (1997). The PowerPoint presentation is included as appendix #10. Obsolescence is a condition of being antiquated, old-fashioned, or out-of-date. The driving factors for obsolescence are:

- technological changes,
- regulatory changes,
- economic/social changes
- value/behavioral changes.

An analogy to compare traffic operations assets and physical assets was discussed to illustrate what happens when they become obsolete. When a new technology is developed for a cell phone, the technology will displace obsolete cell-phones, for example, in only 3 years. However, a new technology in bridge structure or model will not displace existing bridges. Rather, this new technology will be applied as an *upgrade* to the existing facilities. On a different note, a long range plan may not be suitable to plan obsolescence for traffic operations, especially because it is difficult to determine the type of technologies that will become available in the next 20 years. A 10 year time horizon may be more appropriate to plan obsolescence for traffic operations, considering more predictability in advancements of related technology.

The terminology of service life (or life expectancy) that is used to determine how long particular assets will last may not be easily translated to traffic signals and/or other traffic operations assets. Service life in traffic operations assets tends to be a false phrase, because it is difficult to define. Replacement in traffic operations is rarely made systematically as happens in, for example, pavement and bridge maintenance and rehabilitation. Rather, a replacement is incrementally made based on parts that are no longer functioning. In other words, replacement is not made because the time period ends but because the obsolete equipment is no longer functioning. Thus, there should be recognition that traffic operations asset replacement is spread out over time, resulting from difficulties in determining life expectancy.

A discussion of traffic operations devices or systems replacement is too “simplistic and transparent” if it is based on how much it costs to build particular systems, or to install particular devices. Because of life expectancy uncertainties, it may be important to consider the trend of what needs to be prepared, how much repairs are likely to be, and how these needs fit into a maintenance program.

In order to anticipate the absence of support for ITS devices or systems from manufacturing companies, industries should be encouraged to work together to develop standardized compatibility for devices or systems, throughout the ITS. The discussion centered around compatibility on coding and system architecture. To illustrate, when a company is no longer manufacturing assets, or providing maintenance supports, users can still use the same type of assets from other companies. Not only does this partnership

solve compatibility issues, it also ensures technological backwards compatibility in traffic operations assets/systems.

For TOA maintenance, it is important to explore the benefits from an economic perspective *between preventive and corrective maintenance*. For replacement, on the other hand, *a minimum Level of Service (LOS) needs to be defined*. Further, historical data related to replacement—that is, advancement technologies and replacement cycles—needs to be maintained, including what specific factors drive the replacement.

In order to ease traffic operations businesses, three aspects were highlighted during the discussions:

- developing a set of decision and communication tools so that each policy action related to traffic operations can be made through structured mechanisms
- tying system performance with ITS investment so that it is recognizable how investment in traffic operations can significantly impact system performance
- showing the importance of system reliability resulting from maintenance so that decisions on maintenance are tailored to an overall performance of traffic operations

It was noted that an example from state current practices of business approaches in communicating traffic operations issues with state legislature is needed. California DOT (Caltrans) offered their Baseline Inventory that may be similar in this context. The Baseline Inventory is a tool that Caltrans uses in communicating with the Department of Finance (DOF) in requesting additional resources.

In the area of software obsolescence, three common threads emerged. The following, in order of importance, are selected by the peer exchange participants:

1. *Operating Systems (OS) for central system and Wide Area Network (WAN)*. It is crucial to support the operation of a central hub for traffic operations assets and systems, and for communication with other agencies. In addition, the reliability of the central system needs to be managed in a uniform level nationally, as well as monitoring and measuring its performance in meeting standard operations.
2. *Communication fiber optics fields to a Traffic Management Center (TMC)*. It is important to ensure that system communication links all field devices to TMC.

3. *Field devices as input and output.* The operation of field devices should be optimized as both an input (recording field information) and an output (receiving central information) devices.

It was also noted during the discussion that in order to learn from some of the problems in the area of software obsolescence, it was necessary to look at other industries such as the Military or the Federal Aviation Administration (FAA), which may have similar issues especially related to central system communication as indicated in the first point of an earlier discussion.

Considering the challenge of securing funding for traffic operations, another issue was brought up: how meeting these needs can help ease the planning processes, especially when discussing the maintenance budget? The issue, however, is still unresolved. A budget decision involves a number of different aspects beyond the scope of traffic operations.

Two national standards were identified during the obsolescence planning discussion:

- *Technological level and configuration.* This standard is expected to address strategies on performance changes and technological trends
- *Maintenance.* This standard is expected to address life-span for traffic operations and operational performance

Software Systems

Don Schell (WisDOT) and Jason Bittner (MRUTC) co-led the software systems breakout session. The discussion was initiated with the issue that software development needs to closely involve potential users so that software solutions meet actual expectations. The active collaboration between information technology (IT) groups and ITS groups is expected to occur as early in the contracting stage as possible and continue all the way through implementation, to develop shared understandings between planners and users in the context of software development and utilization. In addition, in order to ensure the continuity of software uses, dedicated IT staffs are necessary in the ITS groups.

Software has to be able to track every individual device installed as well as to track archived data to identify any device's false in the systems. Further, it is necessary for software to be flexible so that it can be customized by either in-house staff or non-software developer vendors. Customization to meet particular user or project needs will eventually avoid unnecessary software replacements. Source code ownership can be a solution, which needs to be agreed to in a contracting stage.

There is a general tendency that ITS groups are avoiding IT groups. There is an unclear relationship, structurally, within an organization between IT and ITS, however, it is often found where ITS groups are asked to follow a protocol made by IT groups. Part of the national discussion needs to include debate on what roles do IT and ITS have, and how they should be coordinated, or not, within the corridors of traffic operations? What implications do we have for traffic operations? This kind of problem can occur not only in a small scope in a transportation agency, but also in a bigger scope, in some cases, where ITS is considered as part of the state IT strategic plan.

Issues on data stewardship are becoming apparent from both technical and business perspectives. Several states noted that comprehensive plan development within operations planning has included such concerns.

Two state transportation agency practices in system integration were featured during the discussion:

- MDOT has integrated almost all systems within the agency in a single database using an Oracle system.
- WisDOT has integrated a few databases; for example: device manager, inventory location and system information, and core system and maintenance database.

Maintenance Contracting and Labor Expertise

This session started with a presentation from Caltrans by Felix Zambrano and Todd Szymkowski (UW-Madison) led a discussion during a combined breakout session addressing maintenance contracting and labor expertise.

In his presentation, Zambrano highlighted how Caltrans manages maintenance contracting for Traffic Operations System Network (TOSNET), where he is the regional

TOSNET coordinator (RTC). TOSNET’s repair maintenance contract focuses on repairing and maintaining the communication infrastructure, network systems, and all associated equipment that comprise TOSNET. It is billed at a 24 x 7 on-call hourly rate, with a multi year contract (3 years) for 8 districts currently served by TOSNET. Further, Caltrans has a designated Maintenance Contract Manager (MCM), who issues work orders to the Contractor. In addition, the Traffic Operations group creates Trouble/Repair tickets and then provides a prioritized list to the district MCM. RTC administers the implementation of the contract and acts as the liaison between the district MCM, Traffic Operations, and the Contractor. Lastly, the Contractor provides journeyman telecommunications technicians who are paid in accordance with the State general prevailing wage rate.

Szymkowski initiated a discussion on how one group should interact with other groups from a perspective of labor expertise within TOAMS activities (Figure 7). A total of 8 TOAMS activities are specified. Based on the discussion, a state is expected to have lead roles (L) in 5 TOAMS activities. Three other activities are expected to be led by three other groups: contracted vendors for application development, contractor on-site for TOAM training, and a university or other agency monitoring performance. A few supporting roles (S/s) are indicated as well for 3 TOAM activities.

Figure 7 Groups interaction within TOAMS activities

	State	Contractor Vendor	Contractor On-Site	Other Agency (University, State IT, etc)
1. Planning and Programming	L			
2. TOAMS Design / Project Management	L	s	S	s
3. Application Development	S	L		
4. Database Development	L			
5. Software Administration/Maintenance	L		S	
6. TOAMS Training			L	
7. TOAMS users	L			
8. Performance Monitoring				L

L: lead role; **S:** primary supporting role; **s:** secondary supporting role

Further discussion on labor expertise and maintenance contracting was about the relationship between state DOT and the contractors. Each state has different approaches in maintaining and developing these public private relationships. Therefore, an optimum combination of contractor and state workforces that can provide an effective program should be integrated in a synthesis of best practices.

An official maintenance contracting guide is essential in providing a clear direction for DOT during the processes. The guide should include:

- Scanning and synthesis of practices including contracting approaches and management skills
- Self assessment and/or peer review on processes or programs conducted
- Set of guidance “brochures”

With a number of different research efforts, state DOTs have experienced some difficulties learning from these research reports. In order for a better use of TOAMS related publications, it is desirable to have a single comprehensive TOAMS synthesis that can be used in an executive decision environment as a tool for traffic operations in general, maintenance contracting in particular. This synthesis can possibly be available as an official AASHTO guide to traffic operations.

Predicting the availability of technologies is important so that informed decisions on traffic operations planning can be made.

Further, a national cooperative effort on technological forecasting is needed. Based on the technology forecasted, both operational and organizational impacts should also be estimated.

7. INVESTMENT STRATEGIES

Jason Bittner led the session to investigate major themes for investment in TOAMS. Initiated by Mark Woltmann (WisDOT) with thoughts from a financial management perspective, some major themes were discussed.

There has to be a clear motivation for an investment to meet business case values in traffic operations, which eventually require different traffic operations devices or systems; these values are cost effective values, which will address issues around

performance (i.e., congestion relief, safety, security), and stewardship capability values (i.e., staff specialization and skills).

Investment should be able to facilitate a better partnership between ITS groups and IT groups. To begin, a clear structural level within an organization needs to be clarified between the groups for effective communication.

An invitation to the private sector to participate in traffic operations investment should be considered. A few private investments have been made in physical facilities. The same efforts could be implemented in traffic operations assets.

8. FINDINGS AND RECOMMENDATIONS

Findings

Up-to-date asset management tools are needed for TOA considering the increasing financial commitment made in supporting the operations of roadway networks. However, unique characteristics of TOA have not been well recognized and challenge public officials in developing effective strategies or policies from planning to implementation at statewide levels. Discussion in the peer exchange indicated that many strategies and policies currently used for TOAMS have been regularly used by public officials including legislatures to guide construction and maintenance of traditional transportation infrastructure in the past—especially for pavements and bridges. In fact, the implementation of these strategies and policies led to a number of critical issues causing the effectiveness of the operations of TOA.

Based on the survey of state agencies, a number of teleconferences prior this actual peer exchange, and deliberations at the the peer exchange itself, a number of critical issues of TOAMS were indentified and further described. These issues are categorized in three key themes:

- *Connecting investment and performance.* How can we best communicate the connection between dollars spent and traffic operations performance? How can we address issues of life expectancy in TOA? Can we establish a minimum LOS for TOA? How can maintenance ensure system reliability?

- *Improving planning process.* What time horizon is suitable for TOAMS? How can ITS and IT groups collaborate in TOAMS? How can we address concerns of data stewardship in a comprehensive plan?
- *Promoting public-private partnership.* How can we promote partnership between public and private sectors? Can industries be leveraged to address compatibility issues?

While a number of issues were addressed and future agendas were suggested during the peer exchange, the question of how these would effect to a more efficient planning process, especially when requesting maintenance budget for TOA, remained unclear. Further discussion involving officials working on budgeting issues is needed.

Recommendations

Peer exchange participants developed the following recommendations to advance the effective application of TOAMS. We expect to share these recommendations to state agencies, universities, and other transportation resources.

1. *A national standard for technological level and configuration.* This recommendation addresses strategies of performance changes and technological trends, including concerns of TOA compatibility. Possible advancement of technology issues may arise, somewhat slowing the implementation of new technologies, etc. , however, it is thought that a national standard will help ensure more effective planning processes, leading to more predictable advancements of technology.
2. *A national standard for maintenance.* This recommendation addresses life-span for traffic operations and operational performance. It is intimately related to the establishment of a historical database of TOA replacement and a minimum LOS of TOA. These establishments will help ensure more effective decision making processes in TOA maintenance.
3. *An AASHTO guide to traffic operations.* From a perspective of DOT officials, it is helpful to have a single comprehensive TOAMS synthesis that can be used in an executive decision environment as a tool for traffic operations. This is mainly

considering a number of research reports available, where DOT officials often feel overwhelmed. The guidance will include:

- Scan and synthesis of practices including contracting approaches and management skills
- Self assessment and/or peer review on processes or programs conducted
- Set of guidance “brochures”

9. ACKNOWLEDGEMENTS

The program committee, authors, and participants thank the Wisconsin Department of Transportation for their hospitality when hosting the peer exchange at the Statewide Traffic Operations Center, in Milwaukee, Wisconsin. This included Jackie Mishefske, Lisa Billerbeck, Dean Beekman, Kelly Langer. The authors also thank the planning committee for their hard work in preparing the event, Susan Karcher and Dadit Hidayat.

SUMMARY OF PROCEEDINGS
2008 NATIONAL PEER EXCHANGE
TRAFFIC OPERATIONS ASSET MANAGEMENT SYSTEMS (TOAMS)

APPENDIX 1

AGENDA



AGENDA

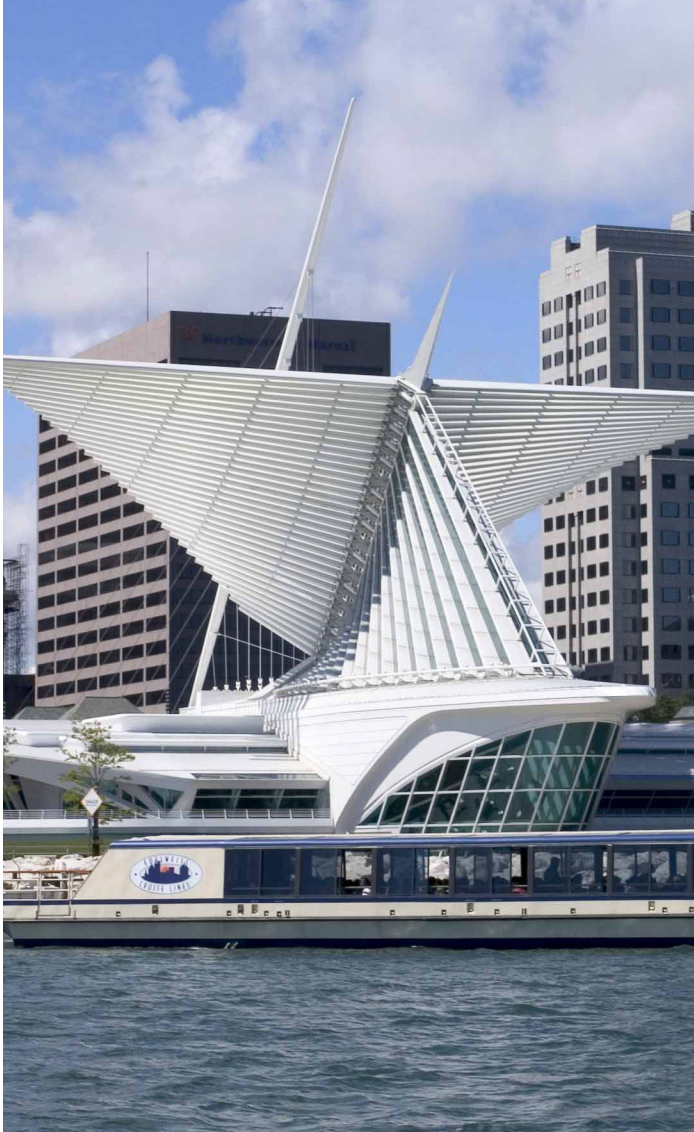

2008 NATIONAL PEER EXCHANGE

TRAFFIC OPERATIONS ASSET MANAGEMENT SYSTEMS (TOAMS)

APRIL 21 - 22, 2008

STATEWIDE TRAFFIC OPERATIONS CENTER
MILWAUKEE INTERMODAL STATION
433 W. ST. PAUL AVENUE
MILWAUKEE, WISCONSIN

SPONSORED BY THE TRANSPORTATION ASSET
MANAGEMENT POOLED FUND RESEARCH PROGRAM

HOSTED BY WISCONSIN DEPARTMENT OF
TRANSPORTATION





2008 NATIONAL PEER EXCHANGE TRAFFIC OPERATIONS ASSET MANAGEMENT SYSTEMS (TOAMS)

APRIL 21 – 22, 2008
STATEWIDE TRAFFIC OPERATIONS CENTER
MILWAUKEE INTERMODAL STATION
433 W. ST. PAUL AVENUE
MILWAUKEE, WISCONSIN

SPONSORED BY ASSET MANAGEMENT POOLED FUND RESEARCH PROGRAM
HOSTED BY WISCONSIN DEPARTMENT OF TRANSPORTATION

GOAL

The national peer exchange workshop on TOAMS will develop a framework for developing and evaluating alternative concepts and partnerships for improving the management, maintenance, and operations of ITS related equipment and systems.

PEER EXCHANGE OBJECTIVES

- Learn from state best practices & peer exchange
- Identify gaps and assess needs for additional research, new methods, improved practices and next steps
- Develop investment strategies for communicating with decision makers

DAY ONE – APRIL 21, 2008

Start	Stop	Activity (<i>location</i>)	Speaker/Facilitator
9:00	9:15	Introduction <i>Room 311A-B</i>	
9:15	9:45	Tour: <i>Statewide Traffic Operations Center</i>	Lisa Billerbeck, Wisconsin
9:45	10:30	Need and Purpose of the Peer Exchange <i>Room 311A-B</i> ♦ Welcome: Purpose and Process ♦ Project Overview ♦ Findings of National Survey	John Corbin, Wisconsin Jason Bittner, UW-Madison Teresa Adams, UW-Madison
10:30	10:45	Break	
10:45	11:45	State Experiences & Expectations <i>Room 311A-B, 5 minutes each</i>	All state participants
11:45	12:45	Lunch	
1:00	2:30	Case Study Presentations <i>Room 311A-B</i> ♦ Michigan Department of Transportation ♦ Oregon Department of Transportation ♦ Discussion on Cases	Greg Krueger, Michigan Galen McGill, Oregon
2:30	2:45	Break	
2:45	4:15	Breakouts ♦ Software Systems <i>Room 307</i> ♦ Obsolescence Planning <i>Room 301</i>	Don Schell, Wisconsin Teresa Adams, UW-Madison
4:30	5:00	Day 2 Overview <i>Room 311A-B</i>	Jason Bittner, UW-Madison
5:00		Group Dinner and Continued Dialogue (Dinner at 6:00pm) <i>The Wicked Hop, 345 N. Broadway Street</i>	



2008 NATIONAL PEER EXCHANGE TRAFFIC OPERATIONS ASSET MANAGEMENT SYSTEMS (TOAMS)

APRIL 21 – 22, 2008
STATEWIDE TRAFFIC OPERATIONS CENTER
MILWAUKEE INTERMODAL STATION
433 W. ST. PAUL AVENUE
MILWAUKEE, WISCONSIN

SPONSORED BY ASSET MANAGEMENT POOLED FUND RESEARCH PROGRAM
 HOSTED BY WISCONSIN DEPARTMENT OF TRANSPORTATION

DAY TWO - APRIL 22, 2008

Start	Stop	Activity	Speaker/Facilitator
8:00		Coffee and Conversation	
8:30	9:00	Open Facilitated Discussions <i>Room 311A-B</i>	Jason Bittner, UW-Madison
9:00	10:30	Case Study Presentations <i>Room 311A-B</i> ♦ Colorado Department of Transportation ♦ Virginia Department of Transportation ♦ Discussion on Cases	Ken DePinto, Colorado Jeff Price, Virginia
10:30	11:00	Break	
11:00	12:15	Breakouts ♦ Labor Expertise <i>Room 301</i> ♦ Maintenance Contracting <i>Room 307</i> - California Department of Transportation	Todd Szymkowski, UW-Madison Dean Beekman, Wisconsin Felix Zambrano, California
12:15	1:00	Lunch	
1:00	2:00	Identify Gaps and Assess Needs <i>Room 311A-B</i>	Scott Bush, Wisconsin
2:00	3:15	Investment Strategies Discussion <i>Room 311A-B</i>	Mark Woltmann, Wisconsin
3:15	3:30	ADJOURN	Jason Bittner, UW-Madison

TRAVEL SAFELY

Upcoming Meetings of Interest for 2008:

- FHWA Smart Roadsides Workshop *Jacksonville, Florida* (April 29-May 1)
- Freeway and Tollway Operations Conference *Fort Lauderdale, Florida* (June 15-19)
- AASHTO Subcommittee on Systems Operations and Management *San Francisco, California*
(August 10-13)
- Mid-Continent Transportation Research Forum *Madison, Wisconsin* (August 13-15)
- ITE Annual Meeting & Exhibit *Anaheim, California* (August 17-20)
- National Rural ITS Conference *Anchorage, Alaska* (September 3-5)
- 15th World Congress on ITS *New York City, New York* (November 16-20)

PARTICIPANTS

2008 NATIONAL PEER EXCHANGE TRAFFIC OPERATIONS ASSET MANAGEMENT SYSTEMS (TOAMS)

TERESA ADAMS, *UW-Madison*
DEAN BEEKMAN, *Wisconsin*
LISA BILLERBECK, *Wisconsin*
JASON BITTNER, *UW-Madison*
SCOTT BUSH, *Wisconsin*
JOHN CORBIN, *Wisconsin*
DOUG DEMBOWSKI, *Wisconsin*
KEN DEPINTO, *Colorado*
DADIT HIDAYAT, *UW-Madison*
GREG KRUEGER, *Michigan*
BILL LEGG, *Washington*
GALEN MCGILL, *Oregon*
CHARLES MEYER, *AASHTO*
JEFF PRICE, *Virginia*
JAMES ROETHIG, *Idaho*
DON SCHELL, *Wisconsin*
TODD SZYMKOWSKI, *UW-Madison*
PAULO VILLELA, *New York*
AARON WEATHERHOLT, *Illinois*
MARK WOLTMANN, *Wisconsin*
FELIX ZAMBRANO, *California*

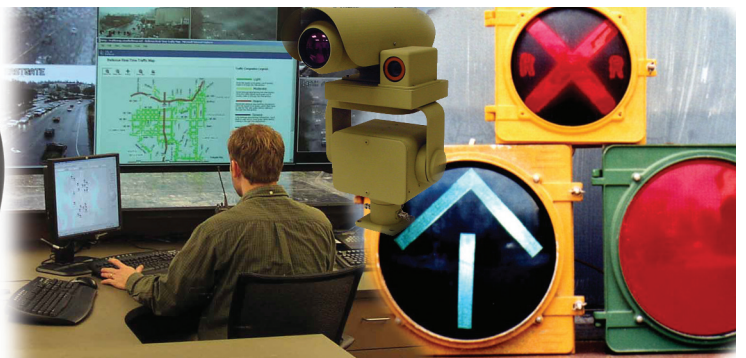

SUMMARY OF PROCEEDINGS
2008 NATIONAL PEER EXCHANGE
TRAFFIC OPERATIONS ASSET MANAGEMENT SYSTEMS (TOAMS)

APPENDIX 2
PARTICIPANT BIOGRAPHIES



2008 NATIONAL PEER EXCHANGE TRAFFIC OPERATIONS ASSET MANAGEMENT SYSTEMS (TOAMS)

APRIL 21 – 22, 2008

STATEWIDE TRAFFIC OPERATIONS CENTER
MILWAUKEE INTERMODAL STATION
433 W. ST. PAUL AVENUE
MILWAUKEE, WISCONSIN

SPONSORED BY ASSET MANAGEMENT POOLED FUND
HOSTED BY WISCONSIN DEPARTMENT OF TRANSPORTATION

TERESA ADAMS is a Professor of Transportation Engineering and City Planning in the Department of Civil and Environmental Engineering at the University of Wisconsin–Madison. She is Director of the Midwest Regional University Transportation Center (MRUTC) and Director of the National Center for Freight and Infrastructure Research and Education (CFIRE), both funded by the USDOT. Dr. Adams has 17 years experience working with state and federal transportation agencies on transportation infrastructure asset management. She is principal investigator for the Traffic Operations Asset Management Systems (TOAMS).

JASON BITTNER is the Deputy Director of the Wisconsin Transportation Center (WisTrans) at the University of Wisconsin. He is also an Associate Researcher in the National Center for Freight and Infrastructure Research and Education (CFIRE). Previous to his work in freight, Jason was a researcher and program manager for the Midwest Regional University Transportation Center at the University of Wisconsin. His research there included analysis of state and local transportation asset management, including performance measurement and maintenance quality assurance. He was the Program Chair for New Directions in Asset Management and Economics: 7th National Conference on Transportation Asset Management. Jason also holds a lecturer appointment in the Department of Civil and Environmental Engineering at the University of Wisconsin and teaches Introduction to the American Political Process and Public Policy Process at Edgewood College in Madison.

SCOTT BUSH manages the Compass program for the Wisconsin Department of Transportation. "Compass" is the WisDOT maintenance quality assurance program that currently tracks data on pavements, shoulders, drainage, roadsides, traffic control and safety devices, winter operations and bridges. Scott has been at WisDOT for 15 years and has also worked for a Metropolitan Planning Organization and a consulting firm.

JOHN CORBIN is the state traffic engineer for the Wisconsin Department of Transportation (WisDOT), and has also served as a freeway operations engineer and ITS program manager in the metropolitan Milwaukee area. Before joining WisDOT 10 years ago, he worked as a traffic control engineer for the city of Milwaukee and as a construction engineer for the Illinois DOT. Corbin chairs the Institute of Transportation Engineers' Traffic Incident Management Committee and AASHTO's Traffic Incident Management Task Force. He is a member of the American Society of Civil Engineers' Traffic Operations Committee, the TRB Freeway Operations Committee, the IEEE Incident Management Working Group, and the ITS America Public Safety Forum. Corbin has a bachelor's degree in transportation engineering from the University of Wisconsin and a master's degree in civil and environmental engineering through the University of Illinois



2008 NATIONAL PEER EXCHANGE TRAFFIC OPERATIONS ASSET MANAGEMENT SYSTEMS (TOAMS)

APRIL 21 – 22, 2008
STATEWIDE TRAFFIC OPERATIONS CENTER
MILWAUKEE INTERMODAL STATION
433 W. ST. PAUL AVENUE
MILWAUKEE, WISCONSIN

SPONSORED BY ASSET MANAGEMENT POOLED FUND
HOSTED BY WISCONSIN DEPARTMENT OF TRANSPORTATION

and the University of Wisconsin. He is a registered professional engineer in Wisconsin, and is nationally certified as a professional traffic operations engineer.

KEN DEPINTO has over 23 years experience in the transportation industry. He has worked in all facets of transportation which include traffic planning, traffic operations, project design and project construction. Ken is currently the Intelligent Transportation Systems (ITS) Branch Manager for CDOT. The ITS Branch handles the collection and dissemination of traveler information statewide for CDOT. This is a relatively new position for Ken and he has been in this position for almost two years. Ken has extensive experience in traffic maintenance and operations and contract administration.

DADIT HIDAYAT has worked for the Wisconsin Transportation Center (WisTrans) at the University of Wisconsin-Madison for 2 years, as a graduate student assistant. He received his masters of science degree in Urban and Regional Planning, and is currently working on a doctorate program in the Nelson Institute for Environmental Studies, both at the UW-Madison. During his time with WisTrans, he worked with the WisDOT's highway program, developing a framework to enhance WisDOT's prior approach for evaluating the emerging development pressure along State Trunk Highway (STH) segments. He also studied the implementation of Wisconsin Information System for Local Roads (WISLR) in local governments as part of the Transportation Management and Policy graduate certificate program at the UW-Madison.

GREG KRUEGER, P.E. is the Michigan Department of Transportation's (MDOT's) Program Manager for the statewide Intelligent Transportation Systems (ITS) program. Currently, he is overseeing all development, deployment, operations and maintenance of ITS throughout the State of Michigan. Greg has been involved in numerous ITS projects across the country, including the development of a 75-mile expansion of the Michigan ITS Center system, the Pueblo, Colorado Freeway Management System, Denver High Occupancy Vehicle Control system and the deployment of various traffic signal systems. He received in Bachelor of Science degree in Civil Engineering from Colorado State University and his masters of science degree in Civil Engineering, with an emphasis on Traffic Engineering from Texas A&M University.

BILL LEGG is the State ITS Operations Engineer for the Washington State Department of Transportation. In this role he is responsible for the coordinated operations of the department's seven traffic management centers and the operations of the statewide incident management program. Additional responsibilities include management of the department's statewide wireless communications network and land mobile radio system and the agencies Commercial Vehicle Services (CVS) division. The CVS division



2008 NATIONAL PEER EXCHANGE TRAFFIC OPERATIONS ASSET MANAGEMENT SYSTEMS (TOAMS)

APRIL 21 – 22, 2008

STATEWIDE TRAFFIC OPERATIONS CENTER
MILWAUKEE INTERMODAL STATION
433 W. ST. PAUL AVENUE
MILWAUKEE, WISCONSIN

SPONSORED BY ASSET MANAGEMENT POOLED FUND
HOSTED BY WISCONSIN DEPARTMENT OF TRANSPORTATION

provides commercial vehicle permitting and operates the states' Commercial Vehicle Information Systems Network (CVISN) and its Weigh in Motion (WIM) systems. Bill also oversees and coordinates operations of the departments 511 phone system with web based traveler information systems and manages the agency's AMBER Alert program.

GALEN MCGILL has been the Intelligent Transportation Systems Manager for the Oregon Department of Transportation since the inception of the ITS Program in 1998. He has worked for ODOT for 20 years in various positions all related to technology development and implementation. Galen is a registered professional engineer. He has a Bachelor's degree in electrical engineering from Oregon State University and an MBA degree from Willamette University's Atkinson Graduate School of Management.

CHARLES MEYER is an eight-year Traffic Operations Engineer with the Colorado Department of Transportation. Charles came to CDOT after serving nine years in the US Coast Guard (under the US DOT at the time). While at CDOT, Charles helped the State's Traffic, Safety, and Operations Offices to transition into CDOT's new enterprise resource planning system by coordinating collection and use of traffic and operations infrastructure asset data. He is currently a Fellow with the American Association of State Highway Transportation Officials (AASHTO) in Washington, D.C. working in the areas of Operations, Safety, Traffic Engineering, and Maintenance. Charles is a registered P.E. and P.T.O.E. He will return to the mountain trails of Colorado with his wife and two kids this summer.

JEFF PRICE is the Assistant Director of Operations Planning at the Virginia Department of Transportation (VDOT). He is responsible for directing and coordinating the annual statewide needs assessment for maintenance and operations; coordinating development and implementation of performance measures for maintenance and operations; developing business requirements for systems to support performance based asset management; and data steward for all System Operations data. He has been with VDOT for over five years. Prior to working for VDOT, he spent two years working as an economist with the USDA Office of the Chief Economist, and about nine years working as a cultural resource management consultant (a.k.a. archeologist). He has a PhD in economics and a Masters in anthropology. He has done many presentations at TRB, AASHTO, and other meetings on performance measures, data business planning, and asset management.

JAMES ROETHIG is the Electronics Digital Equipment Specialist, mobility services – highway operations, for the Idaho Transportation Department (ITD). He has been with ITD for 10 years. During that time, he has been involved with traffic signal timing and development, procedural improvements for highway-rail crossings and signal timing, implementation of



2008 NATIONAL PEER EXCHANGE TRAFFIC OPERATIONS ASSET MANAGEMENT SYSTEMS (TOAMS)

APRIL 21 – 22, 2008

STATEWIDE TRAFFIC OPERATIONS CENTER
MILWAUKEE INTERMODAL STATION
433 W. ST. PAUL AVENUE
MILWAUKEE, WISCONSIN

SPONSORED BY ASSET MANAGEMENT POOLED FUND
HOSTED BY WISCONSIN DEPARTMENT OF TRANSPORTATION

Roadway Weather Information Systems (RWIS), Highway Advisory Radio Systems (HAR), Closed Circuit TV (CCTV), and Dynamic Message Signs (DMS) implementation and maintenance. James is an active member of International Municipal Signal Association (IMSA) as a Level III Technician and Instructor. He hosted the IMSA-NW Section's Annual Conference in 2003. In his spare time, James teaches electronic classes at ITT-Tech, rebuilds houses, gardens, administers Amateur Radio (HAM) Licenses, participates in HAM Radio civil emergency services (RACES & ARES), volunteers for the Special Olympics Worldwide Winter Games, mediates for the Boise County Court, and enjoys backcountry touring, backpacking and fly fishing.

TODD SZYMKOWSKI has 14 years of planning, design, construction inspection, integration, research and evaluation of traffic operations projects and intelligent transportation systems as a project manager/engineer. For the last 5 years Todd has served as the Wisconsin Traffic Operations and Safety (TOPS) Laboratory Program Manager and Deputy Director at the University of Wisconsin-Madison. Main responsibilities include coordinating multiple traffic operations and safety engineering related research activities. Representative projects include development of a Transportation Operations Data Hub, development of a Road Weather Safety Audit Initiative, and multiple roadway safety countermeasure projects. Prior to joining UW-Madison, Todd worked in the private sector for over seven years and the Wisconsin Department of Transportation at the MONITOR Traffic Operations Center for two years. From 2000-2002, Todd led day-to-day operational efforts in a small branch consulting firm office in Madison, Wisconsin.

PAULO VILLELA obtained his BS in Civil Engineering in 1979 and a specialization in Petroleum Engineering in 1980 in his native Brazil. After a ten year career there, first as a Drilling Engineer in a drilling contract project, then as a Civil Engineer for a large Utility Company and finally as the Engineer in Charge of a multi-million dollar offshore drilling contract, Mr. Villela joined NYS Department of Transportation in 1990 as a Civil Engineer in the Materials Group. He moved then to a Regional Construction Group and worked in bridge and highway construction project inspection. Later, he worked as Design Squad Leader in the Geotechnical Engineering Bureau and then in the Rail Safety Bureau as Project Manager overseeing Rail Safety projects and a Communication Based Train Control project. Mr. Villela also developed the Department's Design Guidelines for Interconnection of Grade Crossing Warning Devices and Traffic Signal Systems. He is currently the Asset Manager for the Department's Traffic Signal Program.

AARON WEATHERHOLT is the Engineer of Traffic Operations for the Illinois Department of Transportation in the Central Bureau of Operations in Springfield. He has worked for IDOT in various construction, design, planning and traffic engineering



2008 NATIONAL PEER EXCHANGE TRAFFIC OPERATIONS ASSET MANAGEMENT SYSTEMS (TOAMS)

APRIL 21 – 22, 2008

STATEWIDE TRAFFIC OPERATIONS CENTER
MILWAUKEE INTERMODAL STATION
433 W. ST. PAUL AVENUE
MILWAUKEE, WISCONSIN

SPONSORED BY ASSET MANAGEMENT POOLED FUND
HOSTED BY WISCONSIN DEPARTMENT OF TRANSPORTATION

capacities since 1989 and is a registered professional engineer in Illinois. As the Engineer of Traffic Operations, he is responsible for statewide policies and standards for signing, pavement marking, traffic signals, ITS maintenance, work zone traffic control and, railroad grade crossing and traffic signal interconnect systems. Aaron represents the Illinois Department of Transportation as a member of the National Committee on Uniform Traffic Control Devices, the American Association of State Highway and Transportation Officials Subcommittee Traffic Engineering, and the American Traffic Safety Services Association. Aaron has a Bachelor of Science in Civil Engineering from the University of Missouri - Rolla. He is a graduate of the inaugural class of the Operations Academy Senior Management Program.

MARK WOLTMANN has worked for the Wisconsin Department of Transportation for over 28 years. During this time, he has worked predominantly with the highway program, performing budgetary, financial, and policy-related duties. Mark is currently the chief of the Program Management Section in the Bureau of Highway Operations with responsibilities for financial management as well as program development and analysis.

FELIX ZAMBRANO, P.E. started career in Caltrans 27 years ago as an Electrician in Maintenance department and then worked his way up to become an Electrical Engineer by going to school and working full time simultaneously. Felix started working as an Electrical Engineer in 1986 with the Highway Operations department where he was involved with preparing the design and specifications of one of the first Traffic Operations Systems project in California. In 1991 to 1999, Felix worked with Traffic Systems Electrical design office as an Associate Electronics Engineer and was Project Engineer in various Traffic Operations projects. Then, Felix transition to Associate Telecommunications Engineer in 1999 to 2002 where he was involved in the design and construction oversight of the new Traffic Management Center for District 4 (Bay Area) and also provided support to the TMC network/servers communication system. In April 2001, he became a licensed Professional Engineer in Electrical Engineering. In 2002, Felix moved to the IT department's Wide Area Network group as System Software Specialist II. Beginning in February 2006, Felix started working with the Maintenance Division as Regional Traffic Operations System Network (TOSNET) Coordinator and responsible in preparing TOSNET service contracts, managing the contract implementations and providing Engineering and technical assistance to the Electrical Maintenance and Traffic Operations staff.

SUMMARY OF PROCEEDINGS
2008 NATIONAL PEER EXCHANGE
TRAFFIC OPERATIONS ASSET MANAGEMENT SYSTEMS (TOAMS)

APPENDIX 3
BREAKOUT RESOURCE SHEETS

BREAKOUT RESOURCE SHEET

OBsolescence PLANNING

DESCRIPTION

Obsolescence can answer the question of “How long should an infrastructure last?” Obsolescence does not indicate the item is not functional; it simply does not measure up to current needs or expectations. The four categories that can influence obsolescence:

- *Technological changes*: previously built and it is not compatible with new technology;
- *Regulatory changes*: new law, new standards;
- *Economic or social changes*: urban spread, new land developments can not be accommodated into current roads;
- *Values or behavior changes*: societal commitment to private auto travel, or in the case of commercial drivers, the need to travel in congested areas.

ELEMENTS OF BEST PRACTICES

- Comprehensiveness of monitoring systems
- Performance characterization; through effectiveness, reliability and cost
- Routine reassessments of the utility of the systems
- Establishment of a vision for the overall system rather than attempting to put the proverbial square peg in around hole

POTENTIAL BEST PRACTICES

- *South Carolina DOT*; Implementing a comprehensive ITS maintenance program
- *Utah DOT*; ATMS maintenance, and annual inspection program for traffic signals
- *Virginia DOT*; Building business architecture to address all the components needed (data, technology, systems, processes, organization, and strategic goals)

BARRIERS OR CHALLENGES TO BE ADDRESSED

- Strong partnership between researchers (who conduct studies on life cycles of infrastructure) and practitioners (who are experienced to give judgments about onset obsolescence)
- Measurable and documented knowledge on obsolescence by practitioner community
- Ability to abandon systems that are no longer effectively enhancing the transportation experience

BREAKOUT RESOURCE SHEET

SOFTWARE SYSTEMS

DESCRIPTION

A wide range of software, from sophisticated enterprise-wide systems such as SAP and Oracle, all the way down to simple Excel spreadsheets, has been used in transportation sector. In addition to proprietary software, or commercial off-the shelf (COTS) software, the utilization of in-house software systems are also advanced to support agency day-to-day businesses. In general, based on the characteristics of the systems, two types of software systems are available: integrated software systems and specialized software systems.

The application of software systems can indicate to what extent agencies are applying the asset management principles. A systematic approach to collecting, storing, analyzing, and using information is needed in order to make informed decisions.

ELEMENTS OF BEST PRACTICES

- Efficiency and effectiveness on the use of proprietary software or in-house software
- Knowledge transfer and maintenance on proprietary software
- Indicator to measure significant savings in procurement and maintenance of proprietary software
- Integration of software system with other management system
- Data driven decision making

POTENTIAL BEST PRACTICES

- *Oregon DOT*; Implementing management software for ITS
- *Virginia DOT*; Implementing COTS packages to perform asses and inventory management

BARRIERS OR CHALLENGES TO BE ADDRESSED

- Control over future changes to proprietary software
- Maintain business relationship with external sources that develop the software
- Reduce cost in in-house software development and maintenance
- Integrate with other elements of measurement systems
- Facilitate data storage

BREAKOUT RESOURCE SHEET

MAINTENANCE CONTRACTING

DESCRIPTION

Outsourcing of maintenance activities is normally done if either: the available maintenance capacity is insufficient to meet peak demand (short-term contracting out); or the expected volume is too small and the randomness of the maintenance related to a particular skill too large to justify at least one professional on standby (strategic contracting out). A number of conditions will need to be established in order to make long-term savings from these activities.

- *Scale*; Contracting should be considered when the agency is either too small or too large to take advantage of optimal economies of scale, provided, of course, that the contractor can capture these scale of economies.
- *Scope*; Contracting is a viable option when the contractor can benefit from economies of scope while the agency cannot.
- *Organization*; Contracting is often considered when governance structure is overgrown, however, structural reform is also necessary.
- *Competition*; More of the cost savings will be passed on to the client when the contractors, including government entities, compete for the contract.
- *Managing Contracting Out*; the costs of the contract process need to be properly calculated so that they are less than the costs of continued internal production.

ELEMENTS OF BEST PRACTICES

- Clear definition about maintenance activities between those to be kept in-house and those to be outsourced
- Structured mechanism for contractor selection
- Maintain a collaborative relationship between agency and contractor

POTENTIAL BEST PRACTICES

- *CalTrans DOT*; Outsource maintenance on statewide basis with some regional specialization
- *Idaho DOT*; Selecting good contractor, and outsourcing ITS maintenance
- *New York State DOT*; *vendor selection*
- *Oregon DOT*; Aligning maintenance funding for ITS with capital construction funding
- *Utah DOT*; Open-end maintenance contracts for lighting

BARRIERS OR CHALLENGES TO BE ADDRESSED

- Make contracts that are easy to measure, understand, and reproduce
- Define both the missions and the measures of contracts
- Monitor contractors beyond measurements specified in contracts
- Work collaboratively, not adversarially, with contractors

BREAKOUT RESOURCE SHEET

LABOR EXPERTISE

DESCRIPTION

The overlap of asset management and traffic operations in the management of operations components of roadway networks require particular skills that can address both aspects simultaneously and efficiently. However, the randomness of the maintenance-related businesses in traffic operations is too large to justify the skills needed. On one hand, agencies cannot continuously rely on outsource services or products because they might slowly lose control over their own service deliveries. On other hand, limited budget is available to advance agency knowledge and expertise. This ties closely to contracting maintenance activities.

ELEMENTS OF BEST PRACTICES

- Collaboration and cooperation with private agencies and other public agencies for knowledge transfer
- Post service delivery or product development relationship
- Training programs
- Needs assessments
- Adopting specific activities to encourage use of existing skill sets (e.g. IT lecture series)

POTENTIAL BEST PRACTICES

- *Wisconsin DOT*; collaboration and cooperation between in-house staffs and privatized maintenance contractors

BARRIERS OR CHALLENGES TO BE ADDRESSED

- Establish systematic knowledge transfer between agencies and private sectors
- Advance outsourcing to identify new development on products and services
- Encourage partnership in the area of transportation operations
- Develop training series for maintenance staff that are affective and time efficient, and meet knowledge areas needed

SUMMARY OF PROCEEDINGS
2008 NATIONAL PEER EXCHANGE
TRAFFIC OPERATIONS ASSET MANAGEMENT SYSTEMS (TOAMS)

APPENDIX 4
SURVEY QUESTIONNAIRE

Agency Profile

1. Location of the agency * required

2. Name of your agency * required

3. Type of Agency

- Federal
 State
 Local

4. Does your agency use proprietary software for TOAMS?

- No
 If Yes, How important is the software? (1=High, 5=Low)

5. Does your agency use in-house developed software for TOAMS?

- No
 If Yes, How important is the software? (1=High, 5=Low)

6. Check all the components your agency manages

	Manages	Don't have
511 Telephone Dial-in Service	<input type="checkbox"/>	<input type="checkbox"/>
Advanced Traffic Management System	<input type="checkbox"/>	<input type="checkbox"/>
Advanced Traveler Information System	<input type="checkbox"/>	<input type="checkbox"/>
Automated Crash Notification System	<input type="checkbox"/>	<input type="checkbox"/>
CCTV Cameras (traffic surveillance)	<input type="checkbox"/>	<input type="checkbox"/>
Incident Management System	<input type="checkbox"/>	<input type="checkbox"/>
Loop Detectors (traffic count, occupancy and speed)	<input type="checkbox"/>	<input type="checkbox"/>
Pavement Sensors (temperature)	<input type="checkbox"/>	<input type="checkbox"/>
Road Weather Information System	<input type="checkbox"/>	<input type="checkbox"/>
Signal System (signal heads, controllers)	<input type="checkbox"/>	<input type="checkbox"/>
VMS Controllers	<input type="checkbox"/>	<input type="checkbox"/>

8. Does your agency have any of the following formal process applied to the components listed? Check all that apply

	Automated Crash Notification System	Advanced Traveler Information System	Advanced Traffic Management System	Incident Management System	Road Weather Information System
Budget planning for maintenance and replacement	<input type="checkbox"/>	<input type="checkbox"/>	<input type="checkbox"/>	<input type="checkbox"/>	<input type="checkbox"/>
Communications Network Management	<input type="checkbox"/>	<input type="checkbox"/>	<input type="checkbox"/>	<input type="checkbox"/>	<input type="checkbox"/>
Dedicated staff	<input type="checkbox"/>	<input type="checkbox"/>	<input type="checkbox"/>	<input type="checkbox"/>	<input type="checkbox"/>
Estimate personnel needs	<input type="checkbox"/>	<input type="checkbox"/>	<input type="checkbox"/>	<input type="checkbox"/>	<input type="checkbox"/>
Field equipment inventory	<input type="checkbox"/>	<input type="checkbox"/>	<input type="checkbox"/>	<input type="checkbox"/>	<input type="checkbox"/>
Maintenance record and management	<input type="checkbox"/>	<input type="checkbox"/>	<input type="checkbox"/>	<input type="checkbox"/>	<input type="checkbox"/>
Make assessment on deficiencies	<input type="checkbox"/>	<input type="checkbox"/>	<input type="checkbox"/>	<input type="checkbox"/>	<input type="checkbox"/>
Make purchase decision(s)	<input type="checkbox"/>	<input type="checkbox"/>	<input type="checkbox"/>	<input type="checkbox"/>	<input type="checkbox"/>
Perform life-cycle cost analysis	<input type="checkbox"/>	<input type="checkbox"/>	<input type="checkbox"/>	<input type="checkbox"/>	<input type="checkbox"/>
Performance monitoring	<input type="checkbox"/>	<input type="checkbox"/>	<input type="checkbox"/>	<input type="checkbox"/>	<input type="checkbox"/>
Propose new improvement project	<input type="checkbox"/>	<input type="checkbox"/>	<input type="checkbox"/>	<input type="checkbox"/>	<input type="checkbox"/>
Schedule maintenance repair and/or replacement	<input type="checkbox"/>	<input type="checkbox"/>	<input type="checkbox"/>	<input type="checkbox"/>	<input type="checkbox"/>
Spare parts inventory	<input type="checkbox"/>	<input type="checkbox"/>	<input type="checkbox"/>	<input type="checkbox"/>	<input type="checkbox"/>
Written Guidelines	<input type="checkbox"/>	<input type="checkbox"/>	<input type="checkbox"/>	<input type="checkbox"/>	<input type="checkbox"/>
Others	<input type="checkbox"/>	<input type="checkbox"/>	<input type="checkbox"/>	<input type="checkbox"/>	<input type="checkbox"/>

Asset Use and Data Collected

9. For each asset, what data do you keep on your inventory? (check all that apply)

	Characteristics / Capabilities	Maintenance Requirements	Maintenance Cost History	Repair / Failure History	Age / Condition
511 Telephone Dial-in Service	<input type="checkbox"/>	<input type="checkbox"/>	<input type="checkbox"/>	<input type="checkbox"/>	<input type="checkbox"/>
Advanced Traffic Management System	<input type="checkbox"/>	<input type="checkbox"/>	<input type="checkbox"/>	<input type="checkbox"/>	<input type="checkbox"/>
Advanced Traveler Information System	<input type="checkbox"/>	<input type="checkbox"/>	<input type="checkbox"/>	<input type="checkbox"/>	<input type="checkbox"/>
Automated Crash Notification System	<input type="checkbox"/>	<input type="checkbox"/>	<input type="checkbox"/>	<input type="checkbox"/>	<input type="checkbox"/>
CCTV Cameras (traffic surveillance)	<input type="checkbox"/>	<input type="checkbox"/>	<input type="checkbox"/>	<input type="checkbox"/>	<input type="checkbox"/>
Incident Management System	<input type="checkbox"/>	<input type="checkbox"/>	<input type="checkbox"/>	<input type="checkbox"/>	<input type="checkbox"/>
Loop Detectors (traffic count, occupancy and speed)	<input type="checkbox"/>	<input type="checkbox"/>	<input type="checkbox"/>	<input type="checkbox"/>	<input type="checkbox"/>
Pavement Sensors (temperature)	<input type="checkbox"/>	<input type="checkbox"/>	<input type="checkbox"/>	<input type="checkbox"/>	<input type="checkbox"/>
Road Weather Information System	<input type="checkbox"/>	<input type="checkbox"/>	<input type="checkbox"/>	<input type="checkbox"/>	<input type="checkbox"/>
Signal System (signal heads, controllers)	<input type="checkbox"/>	<input type="checkbox"/>	<input type="checkbox"/>	<input type="checkbox"/>	<input type="checkbox"/>
VMS Controllers	<input type="checkbox"/>	<input type="checkbox"/>	<input type="checkbox"/>	<input type="checkbox"/>	<input type="checkbox"/>

10. How frequently your agency use the following components and systems (1 = Daily , 5 = Yearly or Never)

	1	2	3	4	5
511 Telephone Dial-in Service	<input type="radio"/>	<input type="radio"/>	<input type="radio"/>	<input type="radio"/>	<input type="radio"/>
Advanced Traffic Management System	<input type="radio"/>	<input type="radio"/>	<input type="radio"/>	<input type="radio"/>	<input type="radio"/>
Advanced Traveler Information System	<input type="radio"/>	<input type="radio"/>	<input type="radio"/>	<input type="radio"/>	<input type="radio"/>
Automated Crash Notification System	<input type="radio"/>	<input type="radio"/>	<input type="radio"/>	<input type="radio"/>	<input type="radio"/>

	1	2	3	4	5
CCTV Cameras (traffic surveillance)	<input type="radio"/>	<input type="radio"/>	<input type="radio"/>	<input type="radio"/>	<input type="radio"/>
Incident Management System	<input type="radio"/>	<input type="radio"/>	<input type="radio"/>	<input type="radio"/>	<input type="radio"/>
Loop Detectors (traffic count, occupancy and speed)	<input type="radio"/>	<input type="radio"/>	<input type="radio"/>	<input type="radio"/>	<input type="radio"/>
Pavement Sensors (temperature)	<input type="radio"/>	<input type="radio"/>	<input type="radio"/>	<input type="radio"/>	<input type="radio"/>
Road Weather Information System	<input type="radio"/>	<input type="radio"/>	<input type="radio"/>	<input type="radio"/>	<input type="radio"/>
Signal System (signal heads, controllers)	<input type="radio"/>	<input type="radio"/>	<input type="radio"/>	<input type="radio"/>	<input type="radio"/>
VMS Controllers	<input type="radio"/>	<input type="radio"/>	<input type="radio"/>	<input type="radio"/>	<input type="radio"/>

System Monitoring

11. What maintenance policies are used for the following components and systems? (check all that apply)

	Preventive Maintenance (Replacement due to experience)	Corrective Maintenance (Replacement when a failure occurs)	Inspection Maintenance (Replacement when an inspection reveals problems)	Replacement (When component is obsolete)
511 Telephone Dial-in Service	<input type="checkbox"/>	<input type="checkbox"/>	<input type="checkbox"/>	<input type="checkbox"/>
Advanced Traffic Management System	<input type="checkbox"/>	<input type="checkbox"/>	<input type="checkbox"/>	<input type="checkbox"/>
Advanced Traveler Information System	<input type="checkbox"/>	<input type="checkbox"/>	<input type="checkbox"/>	<input type="checkbox"/>
Automated Crash Notification System	<input type="checkbox"/>	<input type="checkbox"/>	<input type="checkbox"/>	<input type="checkbox"/>
CCTV Cameras (traffic surveillance)	<input type="checkbox"/>	<input type="checkbox"/>	<input type="checkbox"/>	<input type="checkbox"/>
Incident Management System	<input type="checkbox"/>	<input type="checkbox"/>	<input type="checkbox"/>	<input type="checkbox"/>
Loop Detectors (traffic count, occupancy and speed)	<input type="checkbox"/>	<input type="checkbox"/>	<input type="checkbox"/>	<input type="checkbox"/>

	Preventive Maintenance (Replacement due to experience)	Corrective Maintenance (Replacement when a failure occurs)	Inspection Maintenance (Replacement when an inspection reveals problems)	Replacement (When component is obsolete)
Pavement Sensors (temperature)	<input type="checkbox"/>	<input type="checkbox"/>	<input type="checkbox"/>	<input type="checkbox"/>
Road Weather Information System	<input type="checkbox"/>	<input type="checkbox"/>	<input type="checkbox"/>	<input type="checkbox"/>
Signal System (signal heads, controllers)	<input type="checkbox"/>	<input type="checkbox"/>	<input type="checkbox"/>	<input type="checkbox"/>
VMS Controllers	<input type="checkbox"/>	<input type="checkbox"/>	<input type="checkbox"/>	<input type="checkbox"/>

12. What is your method for determining if the following systems are working?

	Monitoring System	Field Survey	Customer Complaint
511 Telephone Dial-in Service	<input type="radio"/>	<input type="radio"/>	<input type="radio"/>
Advanced Traffic Management System	<input type="radio"/>	<input type="radio"/>	<input type="radio"/>
Advanced Traveler Information System	<input type="radio"/>	<input type="radio"/>	<input type="radio"/>
Automated Crash Notification System	<input type="radio"/>	<input type="radio"/>	<input type="radio"/>
CCTV Cameras (traffic surveillance)	<input type="radio"/>	<input type="radio"/>	<input type="radio"/>
Incident Management System	<input type="radio"/>	<input type="radio"/>	<input type="radio"/>
Loop Detectors (traffic count, occupancy and speed)	<input type="radio"/>	<input type="radio"/>	<input type="radio"/>
Pavement Sensors (temperature)	<input type="radio"/>	<input type="radio"/>	<input type="radio"/>
Road Weather Information System	<input type="radio"/>	<input type="radio"/>	<input type="radio"/>
Signal System (signal heads, controllers)	<input type="radio"/>	<input type="radio"/>	<input type="radio"/>
VMS Controllers	<input type="radio"/>	<input type="radio"/>	<input type="radio"/>

13. Does your agency use any of the following components to monitor level of service (LOS) ?

	Roadway LOS	Intersection LOS	Not Used (N/A)
CCTV Cameras (traffic surveillance)	<input type="checkbox"/>	<input type="checkbox"/>	<input type="checkbox"/>
Loop Detectors (traffic count, occupancy and speed)	<input type="checkbox"/>	<input type="checkbox"/>	<input type="checkbox"/>
Manual Data Collection Program	<input type="checkbox"/>	<input type="checkbox"/>	<input type="checkbox"/>

14. Does your agency monitor compliance with MUTCD standards?

- No
- If Yes, please specify how (software, manual, etc)

15. How are customers able to notify the agency about malfunctioning traffic operations assets?

- Phone
- Online
- Mail
- Not Able to Notify

Issues and Priorities

16. Rate the current importance of these operational issues for your transportation agency?
(1=Very Important, 5=Not Important)

	1	2	3	4	5
Conduct trainings to enhance technical maintenance skills	<input type="radio"/>	<input type="radio"/>	<input type="radio"/>	<input type="radio"/>	<input type="radio"/>
Contracting for system maintenance	<input type="radio"/>	<input type="radio"/>	<input type="radio"/>	<input type="radio"/>	<input type="radio"/>
Improve contractor responsiveness	<input type="radio"/>	<input type="radio"/>	<input type="radio"/>	<input type="radio"/>	<input type="radio"/>
Physical condition assessment	<input type="radio"/>	<input type="radio"/>	<input type="radio"/>	<input type="radio"/>	<input type="radio"/>
Reallocate staff to improve efficiency of operation	<input type="radio"/>	<input type="radio"/>	<input type="radio"/>	<input type="radio"/>	<input type="radio"/>
Reduce repairment or replacement costs	<input type="radio"/>	<input type="radio"/>	<input type="radio"/>	<input type="radio"/>	<input type="radio"/>

	1	2	3	4	5
Repair / Replace equipment	<input type="radio"/>	<input type="radio"/>	<input type="radio"/>	<input type="radio"/>	<input type="radio"/>
Standardize components	<input type="radio"/>	<input type="radio"/>	<input type="radio"/>	<input type="radio"/>	<input type="radio"/>
Upgrade central system	<input type="radio"/>	<input type="radio"/>	<input type="radio"/>	<input type="radio"/>	<input type="radio"/>
Upgrade individual systems	<input type="radio"/>	<input type="radio"/>	<input type="radio"/>	<input type="radio"/>	<input type="radio"/>

17. How does your agency rate the importance of the following initiatives? (1 = Very Important 5 = Not Important)

	1	2	3	4	5
Adjust / Upgrade existing infrastructure system	<input type="radio"/>	<input type="radio"/>	<input type="radio"/>	<input type="radio"/>	<input type="radio"/>
Coordinate agencies across jurisdictions	<input type="radio"/>	<input type="radio"/>	<input type="radio"/>	<input type="radio"/>	<input type="radio"/>
Deploy more system management on ITS facilities	<input type="radio"/>	<input type="radio"/>	<input type="radio"/>	<input type="radio"/>	<input type="radio"/>
Develop a computerized system management module	<input type="radio"/>	<input type="radio"/>	<input type="radio"/>	<input type="radio"/>	<input type="radio"/>
Expand system capabilities	<input type="radio"/>	<input type="radio"/>	<input type="radio"/>	<input type="radio"/>	<input type="radio"/>
Improve technology interaction of ITS system technology	<input type="radio"/>	<input type="radio"/>	<input type="radio"/>	<input type="radio"/>	<input type="radio"/>
More infrastructure system installation	<input type="radio"/>	<input type="radio"/>	<input type="radio"/>	<input type="radio"/>	<input type="radio"/>
Multi agencies coalition, both transportation and non-transportation agencies	<input type="radio"/>	<input type="radio"/>	<input type="radio"/>	<input type="radio"/>	<input type="radio"/>
Prioritizing and scheduling maintenance of ITS systems and components	<input type="radio"/>	<input type="radio"/>	<input type="radio"/>	<input type="radio"/>	<input type="radio"/>

Respondent Information and Interests

18. Who filled out this survey? * required

Name and title

Email

19. Who filled out this survey?

Phone

Fax

20. Would your state send a representative, if travel is funded, to the Transportation Operations Asset Management Systems Peer Exchange and Workshop in Milwaukee, Wisconsin in February 2008?

- No
- If Yes, please list name, title, address, email, phone, and fax

21. Are you interested in presenting or discussing your states' TOAMS program experiences, successes or challenges?

- No
- If Yes, please indicate topic areas.

22. What has your agency done that others can learn from? (Best Practices?)

TOAM Resources

We are requesting TOAMS tools/resources from all state transportation agencies. We will be compiling all materials onto a website. We will contact you to arrange for the collection of these items.

23. Please indicate the TOAMS tools or documents your agency may share with others (check all that apply)

- Inventory management tools
- System Documentation (research report on system development)
- System performance (charts, tables, graphs to illustrate system performance)
- Training materials
- Other, please specify

SUMMARY OF PROCEEDINGS
2008 NATIONAL PEER EXCHANGE
TRAFFIC OPERATIONS ASSET MANAGEMENT SYSTEMS (TOAMS)

APPENDIX 5

**PRESENTATION ON PROJECT OVERVIEW:
JASON BITTNER**



2008 NATIONAL PEER EXCHANGE

**TRAFFIC OPERATIONS
ASSET MANAGEMENT
SYSTEMS (TOAMS)**

APRIL 21 - 22, 2008

STATEWIDE TRAFFIC OPERATIONS CENTER
MILWAUKEE INTERMODAL STATION
433 W. ST. PAUL AVENUE
MILWAUKEE, WISCONSIN

SPONSORED BY THE TRANSPORTATION ASSET
MANAGEMENT POOLED FUND RESEARCH PROGRAM
HOSTED BY WISCONSIN DEPARTMENT OF
TRANSPORTATION

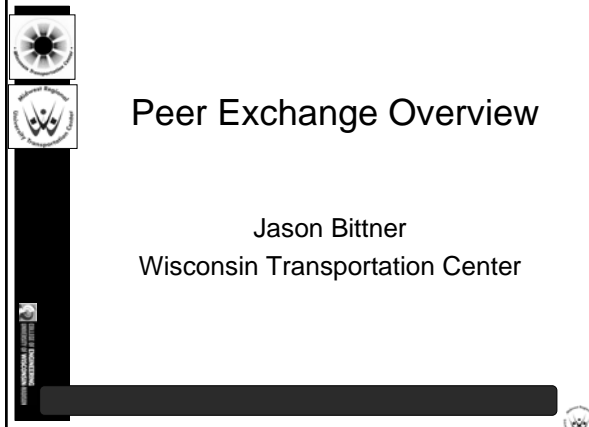

Peer Exchange Overview

Jason Bittner
Wisconsin Transportation Center

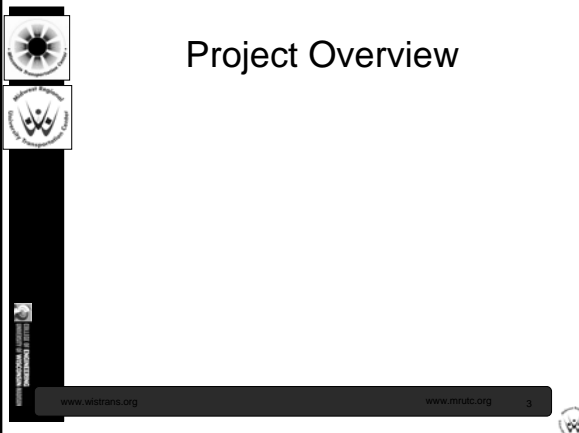

Project Overview

www.wstrans.org www.mutc.org 3

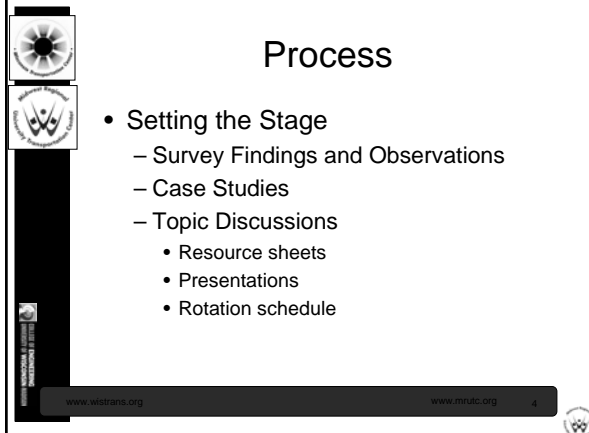

Process

- Setting the Stage
 - Survey Findings and Observations
 - Case Studies
 - Topic Discussions
 - Resource sheets
 - Presentations
 - Rotation schedule

www.wstrans.org www.mutc.org 4

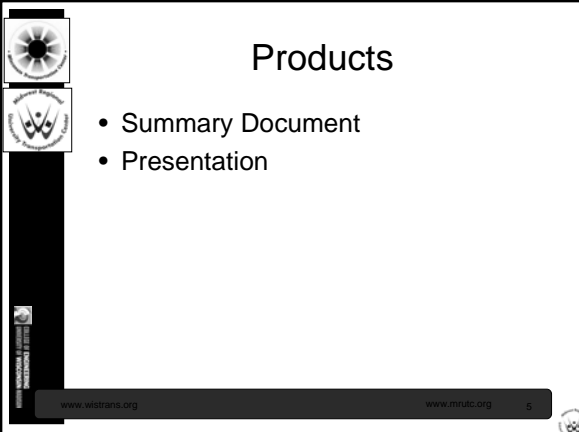

Products

- Summary Document
- Presentation

www.wstrans.org www.mutc.org 5

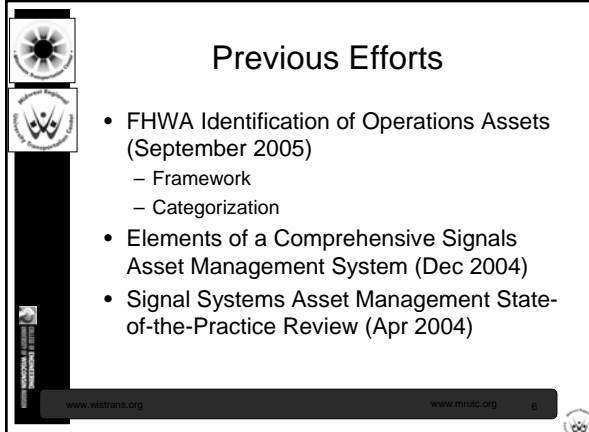

Previous Efforts

- FHWA Identification of Operations Assets (September 2005)
 - Framework
 - Categorization
- Elements of a Comprehensive Signals Asset Management System (Dec 2004)
- Signal Systems Asset Management State-of-the-Practice Review (Apr 2004)

www.wstrans.org www.mutc.org 6



Project

- Approved in April 2007
- MRUTC and TAM Pooled Fund
 - WisDOT Lead
- Develop snapshot on where we need to go from here

www.wistrans.org www.mruc.org



Assignments

- Order Dinner
- Identify gaps and strategies
- Engage and ask questions

www.wistrans.org www.mruc.org



2008 NATIONAL PEER EXCHANGE

TRAFFIC OPERATIONS ASSET MANAGEMENT SYSTEMS (TOAMS)

APRIL 21 - 22, 2008



STATEWIDE TRAFFIC OPERATIONS CENTER
MILWAUKEE INTERMODAL STATION
433 W. ST. PAUL AVENUE
MILWAUKEE, WISCONSIN

SPONSORED BY THE TRANSPORTATION ASSET
MANAGEMENT POOLED FUND RESEARCH PROGRAM
HOSTED BY WISCONSIN DEPARTMENT OF
TRANSPORTATION

SUMMARY OF PROCEEDINGS
2008 NATIONAL PEER EXCHANGE
TRAFFIC OPERATIONS ASSET MANAGEMENT SYSTEMS (TOAMS)

APPENDIX 6



**PRESENTATION OF SURVEY RESULT:
TERESA M ADAMS**

Traffic Operations Asset Management Systems (TOAMS)



Findings on National Survey

Teresa Adams
University of Wisconsin-Madison



Outline

- TOAMS
- Survey of State of Agency
- Observations



What do we mean by TOA?

- Active and dynamic
 - Signs, signals, and ITS devices
- Related tangible and intangible components
 - Communications links, networks, servers, fiber optics, data, software versions
- Monitoring and condition assessment characteristics
 - “bath tub” mortality curve
 - Average time to failure
 - Technical obsolesces
 - Field maintenance





TOAM

- What is Traffic Operations Asset Management?
 - A systematic process of maintaining, upgrading, and operating physical assets of ITS devices and other traffic operations hardware and systems.
- Combines
 - Engineering, business management, economics, and the latest computer-aided technology.





Survey of State Agencies

State Survey

- Purpose
 - Assess and provide information on the national status of TOAMS
 - Gauge areas of interest and potential participation in the peer exchange
 - Collect resources for online distribution

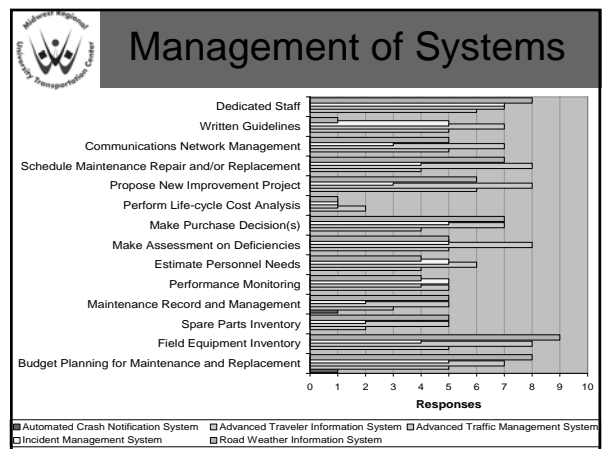
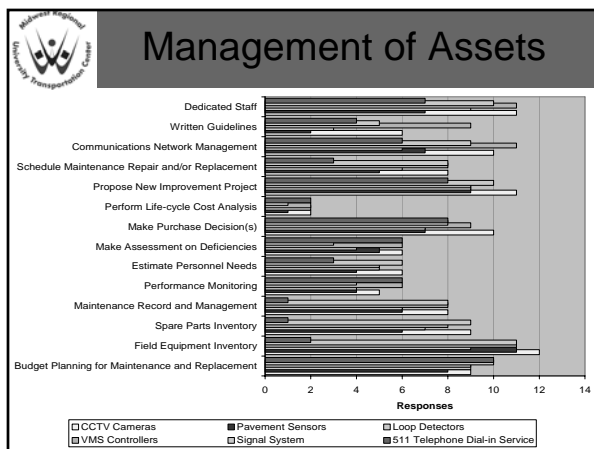
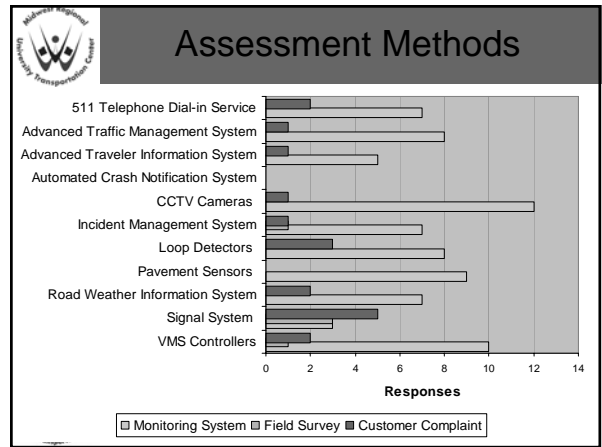
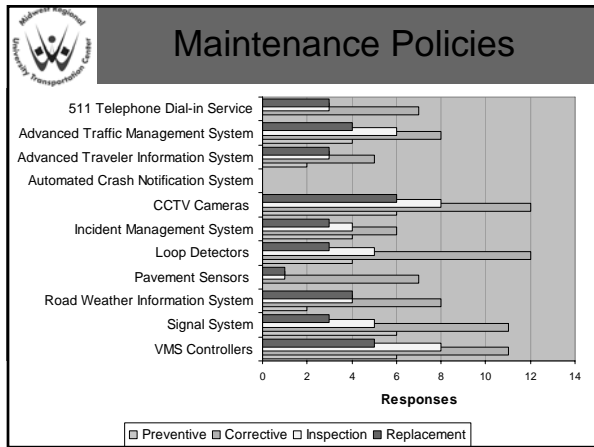
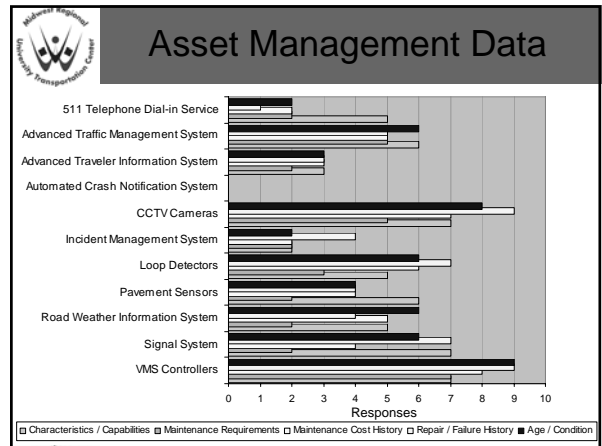
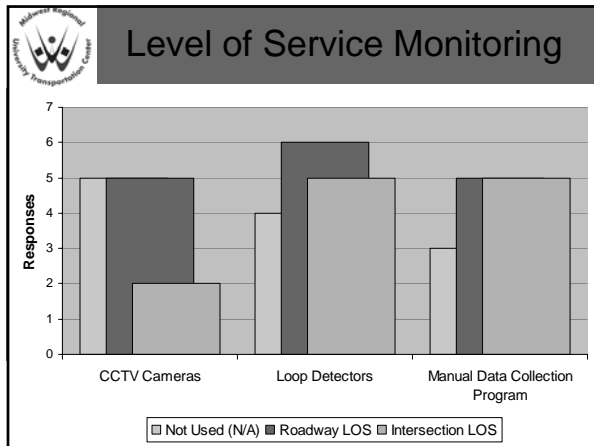

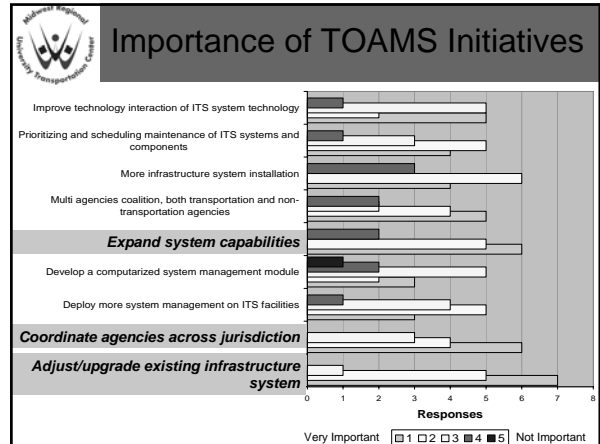
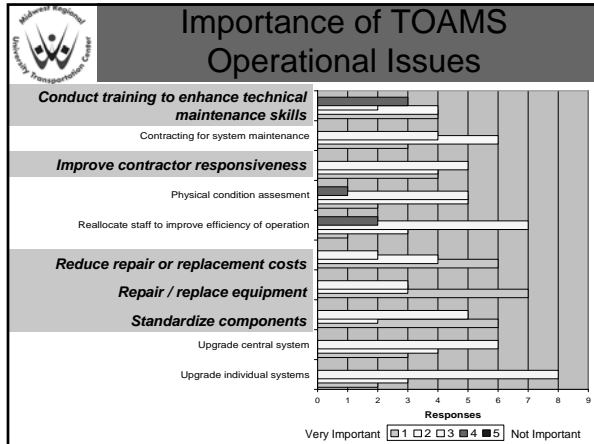

- ### Observations
- Assets and Systems
 - All agencies manage CCTV cameras and RWIS
 - Most manage pavement sensors, loop detectors, VMS controllers and signals
 - Few manage Automated Crash Notification Systems
 - Formal procedures are needed for
 - Estimating personnel needs
 - Managing Maintenance records
 - Assessing system deficiencies
 - Life cycle cost analysis
 - Performance monitoring
 - Managing the spare parts inventory

- ### Observations
- Less than 1/2 of the agencies keep inventory date on their traffic operations assets
 - Agencies most commonly used corrective maintenance (rather than preventive, inspection or replacement strategies)
 - Agencies assess the functioning condition of traffic operations asset through system monitoring (rather than field inspection or customer complaints)

- ### Observations
- Most Important Operational Issues
 - Conduct training to enhance technical maintenance skills
 - Improve contractor responsiveness
 - Reduce repair or replacement costs
 - Repair / replace equipment
 - Standardize components
 - Most Important System Initiatives
 - Expand system capabilities
 - Coordinate agencies across jurisdiction
 - Adjust/upgrade existing infrastructure system

Thank you

Acknowledgements

Andrea Bill
 Jason Bittner
 Dadit Hidayat
 Luis Laracuento
 Kelvin Santiago

SUMMARY OF PROCEEDINGS
2008 NATIONAL PEER EXCHANGE
TRAFFIC OPERATIONS ASSET MANAGEMENT SYSTEMS (TOAMS)

APPENDIX 7

**CASE STUDY MICHIGAN DEPARTMENT OF TRANSPORTATION:
GREG KRUEGER**

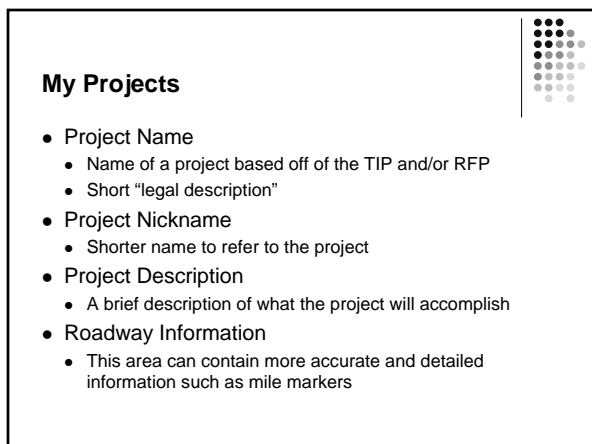
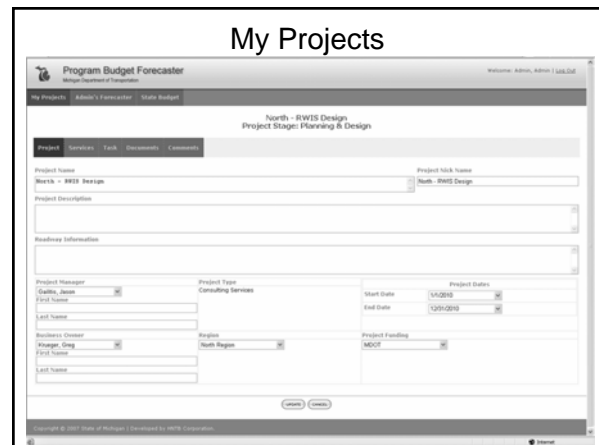
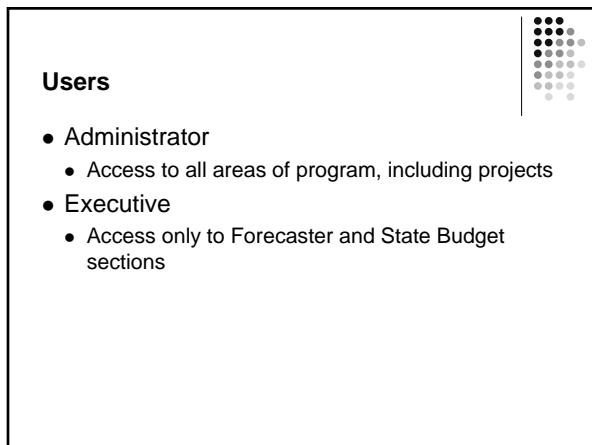
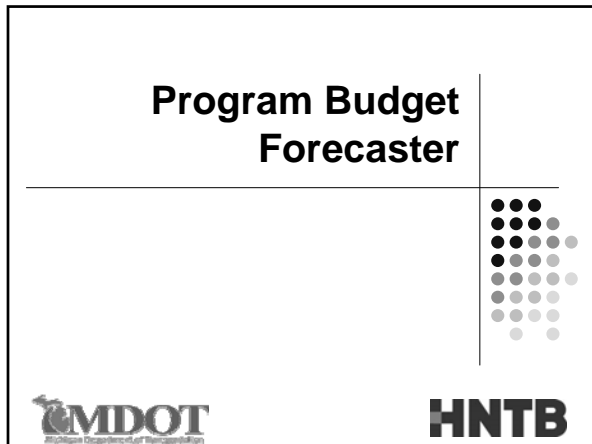

Project Forecasting

- Design Amount
- Construction Amount
- Construction Engineering Amount
- System Manager Amount
- Total Amount



State Budget

Program Budget Forecaster
Michigan Department of Transportation

State Budget

Year	Budget Date	Budget Amount	Created By	Created Date	Updated By	Updated Date
2015	1/1/2015	\$11,500,000.00	Admin, Admin	2/13/2009	Admin, Admin	2/13/2009
2014	1/1/2014	\$11,500,000.00	Admin, Admin	2/13/2009	Admin, Admin	2/13/2009
2013	1/1/2013	\$11,500,000.00	Admin, Admin	2/13/2009	Admin, Admin	2/13/2009
2012	1/1/2012	\$11,500,000.00	Admin, Admin	2/13/2009	Admin, Admin	2/13/2009
2010	1/1/2010	\$9,000,000.00	Admin, Admin	2/13/2009	Admin, Admin	2/13/2009
2009	1/1/2009	\$9,000,000.00	Admin, Admin	2/13/2009	Admin, Admin	2/13/2009
2008	1/1/2008	\$9,000,000.00	Admin, Admin	2/13/2009	Admin, Admin	2/13/2009

Forecaster

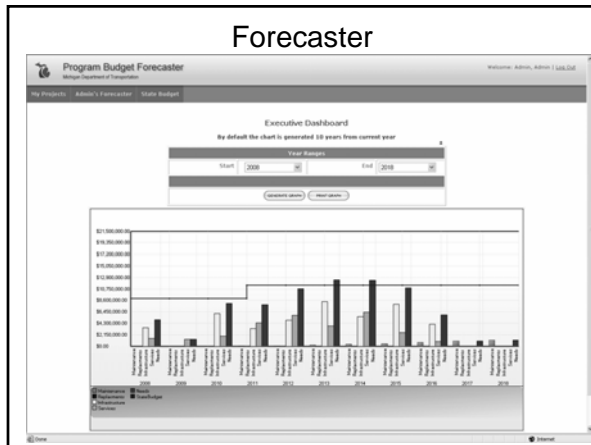

Forecaster

- Maintenance
 - cost to preserve equipment
- Replacements
 - cost to replace equipment that has reached end of life
- Infrastructure
 - cost to deploy infrastructure equipment
- Services
 - cost of operations-based activities not involved in construction
- Needs
 - total cost of previous three components

Project Needs Percentages

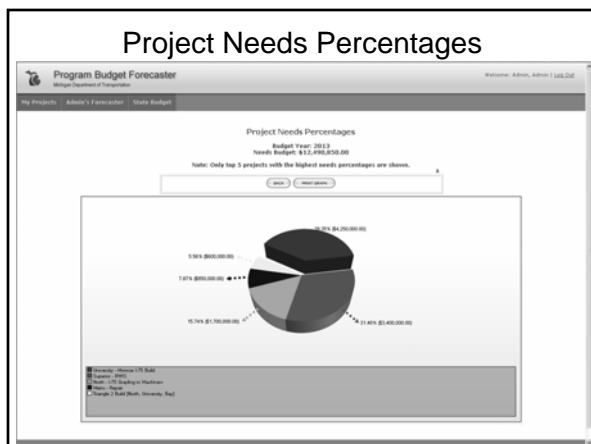

Project Needs Percentages

- Becomes available when needs are projected to overcome state budget
- Displays top five highest spending projects

SUMMARY OF PROCEEDINGS
2008 NATIONAL PEER EXCHANGE
TRAFFIC OPERATIONS ASSET MANAGEMENT SYSTEMS (TOAMS)

APPENDIX 8

**CASE STUDY OREGON DEPARTMENT OF TRANSPORTATION:
GALEN MCGILL**

Oregon Department of Transportation

Operations Asset Management at ODOT

Galen McGill, PE
ITS Manager
April 21, 2008

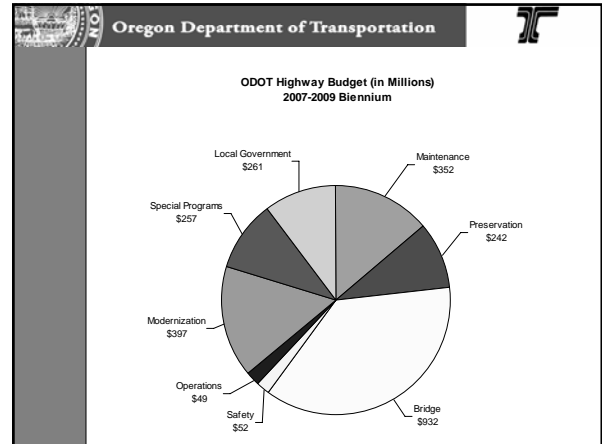

Oregon Department of Transportation

Budget Categories

- Operations
 - Transportation Operations Centers
 - Dedicated Incident Response
 - ITS Program Mgmt
 - Signal Maintenance Program Mgmt
 - Capital Construction for all Traffic Operations assets
- Special Programs
 - Signal, Sign, Illumination Program Mgmt
- Maintenance
 - Maintenance & Operations for all Traffic Operations Assets
 - Incident Response by Maintenance

Oregon Department of Transportation

Ops Capital Budget Process

- Replacement needs
 - Features based
 - Based on feature inventory and expected life
 - Currently no condition data
- Growth
 - Adding features due to traffic growth
- Strategic Investment
 - Improved system operations
 - Regional ITS plans

Oregon Department of Transportation

Operations Assets

Asset	Quantity	Life
Ramp Meters	141	30
Cameras	203	10
Variable Message Signs	71	20
Highway Advisory Radio	20	10
Weather Stations	70	15
Weather Warning Systems	12	15

Oregon Department of Transportation

Operations Assets

Asset	Quantity	Life
Signals	1300	40
Loops	30,000	10
Major Signs	14,762	15
Minor Signs	144,185	15
Illumination	21,000	40
Tunnel lighting systems	9	40

Oregon Department of Transportation

Ops Maintenance Budget Process (ITS Only)

- Centrally Managed – ITS Program
- Statewide Budget
 - Server Replacement
 - Software Maintenance & License fees
 - Program coordination
- Region Budget
 - Based on inventory and average cost per type of asset
- Feature growth - shift budget from capital program to Maintenance
 - 1.7% of capital construction amount for annual O&M

Oregon Department of Transportation

ITS Maintenance Management System

- Micromain
 - Maintenance Management software
 - Cost = \$10,000
 - Source code access for customization
- Features
 - ITS Asset Inventory
 - Manage ITS Maintenance Work
 - Issue/track work orders
 - Preventative maintenance & inspection
 - E-mail/pager notification
 - Timesheets
 - Parts management
 - Reports

Oregon Department of Transportation

System Components

- MicroMain XM
 - Enterprise Client/Server system
- XM Web
 - Web based work order entry & status monitoring
- XM Reports
 - Reporting utility
- Mobile
 - Pocket PC App
 - Download work orders & PM/inspection tasks

Oregon Department of Transportation

Asset Information

Oregon Department of Transportation

Asset Details

Oregon Department of Transportation

Parts List

Part	Description	Qty
Power Supply, PS-1, LedStar	Power Supply	1
VMS, Controller, LCA-19, LedStar	Controller	1
VMS, Controller, CT-23, LedStar	Sign Controller	1
VMS, Exhaust Fan Assy, FAV-29, LedStar	Exhaust Fan Assembly	1
VMS, Fan Sensor, CS-13, LedStar	Fan Sensor	1
VMS, Laptop interface module, ISO15, LedStar	Laptop interface module	1
VMS, LED Board, LDC-27503R31, LedStar	LED Board for Led Star PHS P0024XD	1
VMS, LED Matrix Module, LMM-51, LedStar	LED Matrix Module	1
VMS, Lightning Suppressor, TML-15, LedStar	Lightning Suppressor	1
VMS, LMM Power Supply, PPS-28, LedStar	LMM Power Supply	1
VMS, Logic Control Assy, LCA-21, LedStar	Logic Control Assembly	1
VMS, Photo Sensor, PST-12, LedStar	Photo Cell	1
VMS, RS485 Terminator Assy, TMA-13, LedStar	RS485 Terminator Assembly	1
VMS, RS485 Terminator Assy, TMA-14, LedStar	RS485 Terminator Assembly	1

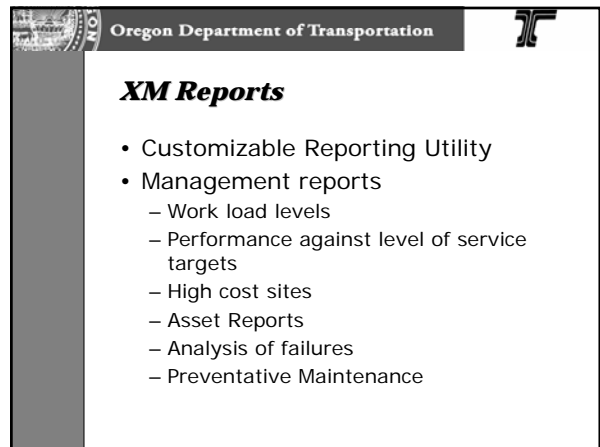
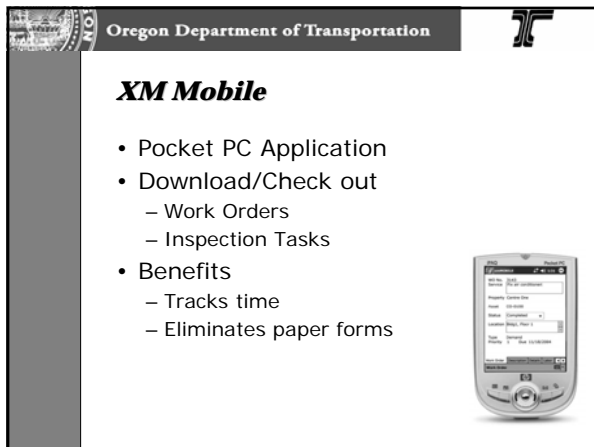
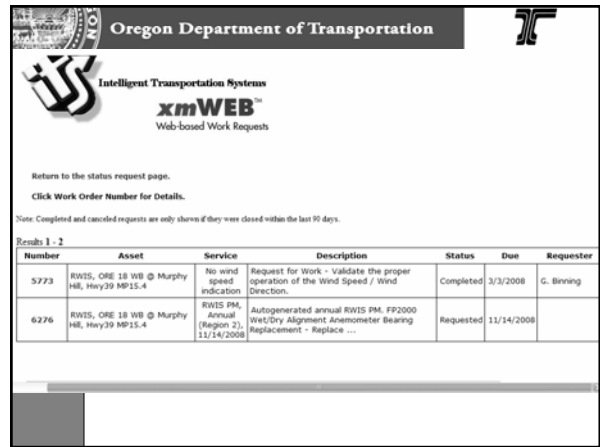
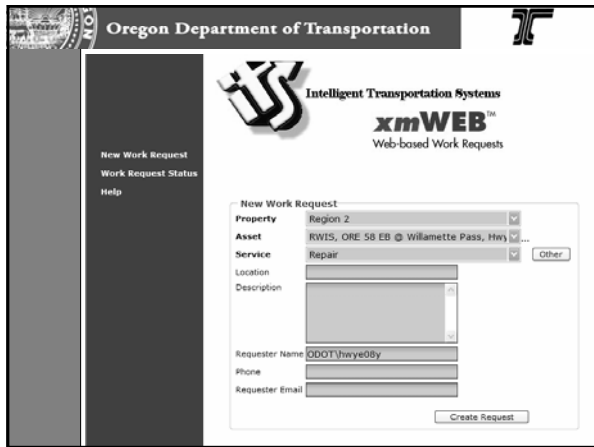
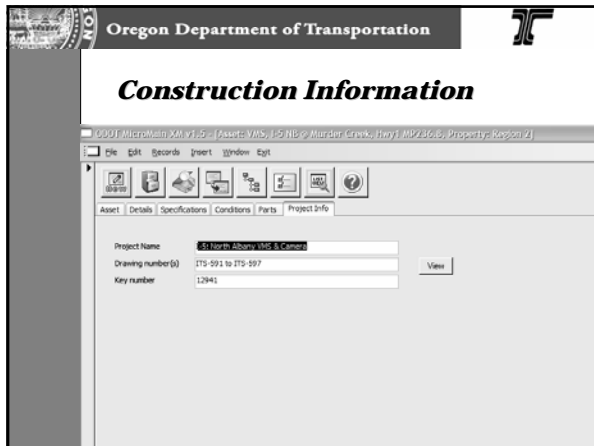

Total Work Orders Region 1		Average Number of Days Between			
Month	Number of work orders	Requested and Issued	Issued and completed	Requested and completed	
Jan-2008	68	26.26	12.89	39.93	
Feb-2008	58	9.95	4.63	14.71	
Mar-2008	118	20.74	17.60	38.34	
Apr-2008	53	12.16	13.48	25.64	
Region Totals:	297	18.37	13.28	31.82	

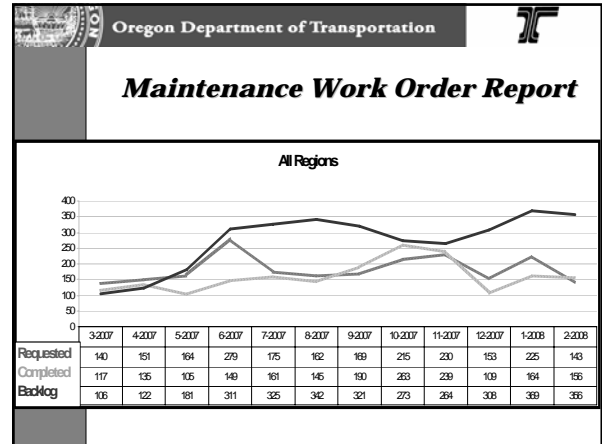

SUMMARY OF PROCEEDINGS
2008 NATIONAL PEER EXCHANGE
TRAFFIC OPERATIONS ASSET MANAGEMENT SYSTEMS (TOAMS)

APPENDIX 9

**CASE STUDY COLORADO DEPARTMENT OF TRANSPORTATION:
KEN DE PINTO**

CDOT ***Presents*** ***I***ntelligent ***T***ransportation ***S***ystems April 2008

1

What is ITS?

- ITS is an application of technology and advanced computer processing to provide services such as:
 - Traveler Information
 - Traffic Management
 - Incident Management

2

Background

- Colorado Transportation Management Center Duties
 - 24/7 Operation
 - Provide Statewide Traveler Information
 - Dispatch Courtesy Patrol
 - Maintain and Operate VMS's/DMS's, CCTV's, Fiber Backbone, 511, etc.
 - Partnerships With Media, Cities, OEM, Counties, Other.



3

An Overview of Intelligent Transportation Systems

- 511
- Partners/Data Sharing
- Trip Travel Time/Speed Maps
- How Do We Operate the Equipment
- Collection and Dissemination of Information
- COTRIP.org (web)
- Maintenance
- Other Miscellaneous Items
- Case Studies

4

511 Traveler Information

- FCC established telephone number for traveler information
- All landline & wireless carriers have switched to allow for 511 service
- CDOT Implemented statewide 511 in Sept 2006



5

Current Capacity

(Capable of answering 138 simultaneous calls)

- Annual call volumes 2005-2007
 - approximately 400 % increase
 - 2007 – 1,722,459
 - 2006 – 1,074,653
 - 2005 – 426,623
- December 2007 (Snap Shot)
 - Highest monthly call volume to date - 451,557
 - On December 31st the system handled 67,301 calls
 - All 138 lines were continually busy between 5 am and 5 pm
 - Larger than Kansas annual average of 400,000
 - Nearly double the annual call volume of Sacramento/Northern California of 250,000
- 2008 call volume for January and February - 732,572
 - 15 % increase from Jan/Feb 2007
 - March call count (3/1-3/6) - 87,514
 - March 2nd (Sunday) call volume was 48,174

6

Call Volumes (January 2005 – February 2008)

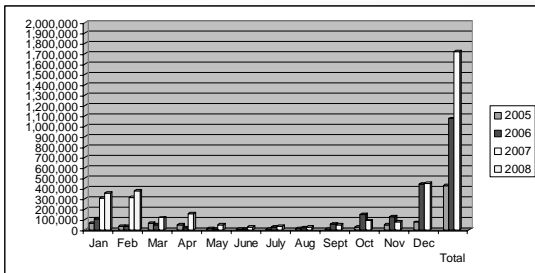

7

Partners/Data Sharing

- Over 100+ Partners
- Depending on the function or service, agreements are in place
- Types of Partners
 1. Internal
 2. State Agencies
 3. Local Agencies
 4. Regional/National Agencies
 5. Media
 6. Private Sector

8

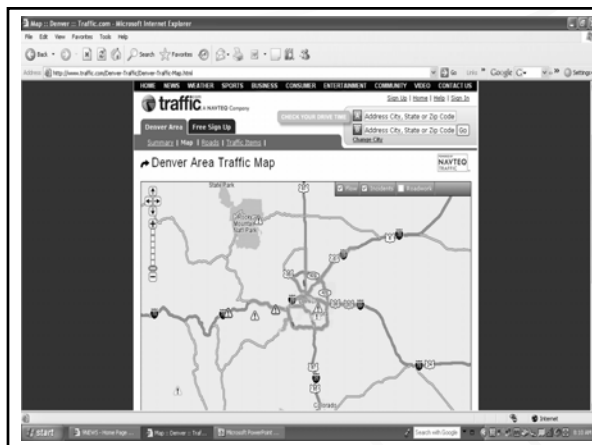

I-70 Trip Travel Time Corridor Characteristics

- Trip Travel Time (Approximately 100 miles – Denver International Airport to Vail)
- Recreational Traffic
- Major commercial vehicle corridor
- Typical Peak Traffic (Friday, Saturday and Sunday)
- Drive Time 3-4 hours on weekends
- Posted Speed Limit 65 MPH
- Alternate Routes - 100 plus mile detours
- Incidents Are Common



10

Purpose Of the Travel Time Application



- Alleviates Driver Frustration
- Provides Drivers Information Prior to Making Travel Plans
- Sent to Communities via Internet (cotrip.org), Phone (511) and Cable TV (video feed to news stations)
- Spreads Out The Peak Periods
- Reduces Secondary Incidents

11

Detection Devices



12

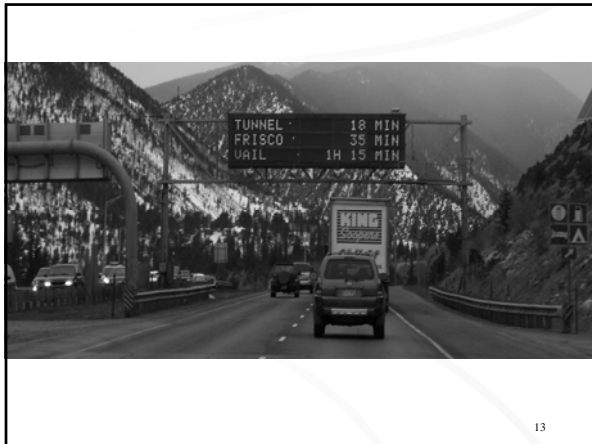

13

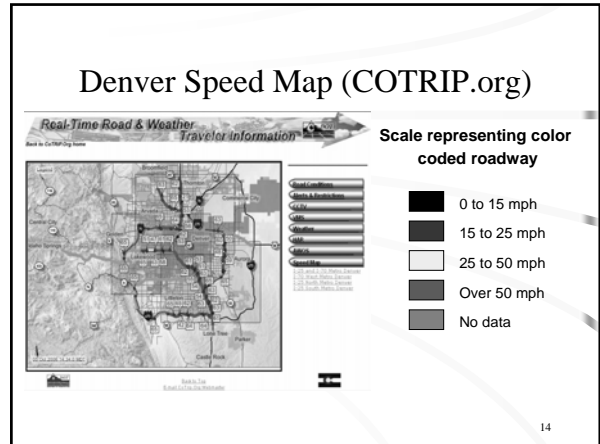

14

How Do We Operate The Equipment?

- Centers
 - Colorado Transportation Management Center (CTMC)
 - Hanging Lake Tunnel (HLT)
 - Eisenhower Johnson Tunnel (EJT)
 - Colorado Springs Transportation Management Center
- Software
 - Custom
 - Off The Shelf
- Communication
 - Fiber Optics (500 plus miles)
 - Cell Phone
 - CDMA
 - Wireless
 - Leased Telephone Lines
 - T1 Telephone Lines

15

Collection and Dissemination of Information

- Dynamic Message Signs
- Interactive Voice Response (IVR)/511
- WEB Site (www.cotrip.org)
- ITS Kiosks
- Broadcast Fax System
- PDA, Cell Phones and E-Mail
- Radio and Television

16

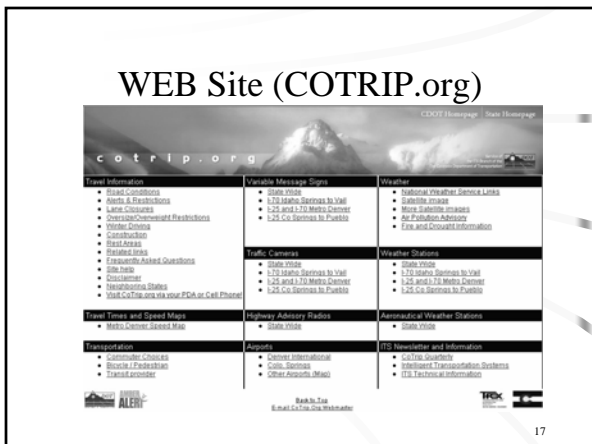

17

Colorado Traffic Management Center

- Transportation Management Operators
- Public Information Officers

18

Generate Alarms

- Segment has speed less than 15 mph for 4 minutes, and / or
- Segment has occupancy of over 50% for 4 minutes
- Share data with cities (Denver, Lakewood)

The screenshot shows a software interface with a summary of alarm counts and a detailed table of events.

Line	Alarm	Alarm Type	Alarm Time	Description	Search	Accession	Resolution
1	21.01	Segment Speed (Congest)	09/22/07 08:14:00 AM	0192121 - on 104th Ave to Thurston Pass. Speed less than 15 mph for the past 4			
2	21.02	Segment Speed (Congest)	09/22/07 08:14:00 AM	0192121 - Thurston Pass to on 104th Ave. Speed less than 15 mph for the past 4 m			
3	21.03	Power Outage	09/22/07 08:49:00 AM	This system has detected a LSC Power Outage on the following I-495, 92.04-97.02.1			

19

How is ITS Equipment Maintained?

- Budget
- Existing Maintenance System
- CDOT's SAP System (Future)
- Sample of Devices (qty)



20

Budget

- \$8.7 Million for maintenance, capital replacement and operations
- \$2.9 Million for utilities, CDOT personal service, software licenses, communications dispatch, etc
- Staffing is 20 CDOT employees and 20-25 contract employees

21

Existing Maintenance System

- Reactive Maintenance
- No true asset management system
- Pole equipment twice daily to check health and then generate maintenance reports
- Crew is made up of 1 CDOT manager and 7 contract employees
- Budget is about \$1.6 Million for contract maintenance salaries and vehicles

22

SAP System

- Inventory is complete
- Work order process is being finalized
- About 1200 devices have been inventoried
- Track labor, materials & equipment and life cycle costs
- Level of Service Reporting
- Ability to report preventative maintenance items (scheduled work)

23

Dynamic Message Signs

- Statewide: 200+



24

Web Shots

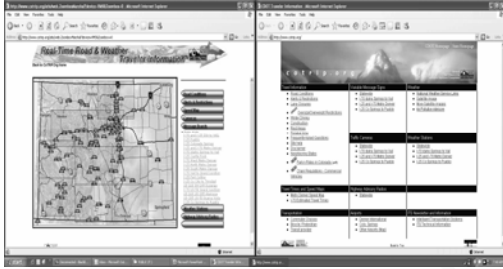

25

Closed-Circuit TVs

- Statewide: 350+



26

Web Shot

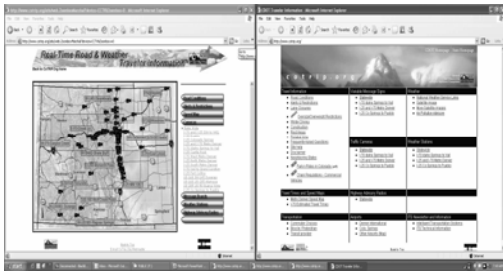

27

Side-Fire Radars

- Statewide: 78



28

Travel Time Indicators

- Statewide: 30+
- Toll Tag Transponders (400,000+)



29

Ramp Meters

- Statewide: 89



30

Weather Stations

- 120+ Statewide



31

Questions

32

What Guides Our Future ITS Investment?

- Strategic plans & Architecture for each CDOT Region and Statewide



33

Case Studies that Measure System Performance

- Case Studies
- Before and After Analysis
- Computer Simulations
- Surveys



34

Eisenhower Johnson Tunnel Maintenance: A Case Study

- Benefits
 - Maintenance activities are performed for 2 weeks in September every year
 - Information on Dynamic Message Signs, Highway Advisory Radio's, Website, Media outlets etc.
 - Percent of traffic reduction attributable to traveler information on I-70 at the Tunnel- 20%

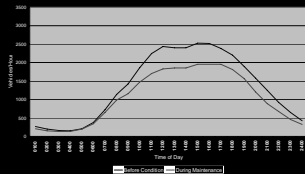

35

Ramp Metering Benefits

- Before/After Studies conducted for new locations (in coordination w/Region 6)
 - **I-25 Southbound (104th Avenue to 84th Avenue)**
 - Nearly two minutes reduction in travel time (~20%)
 - Average speed increased by nearly 9 mph (~31 %)
 - **C-470 Westbound (Bowles Avenue to Quincy Avenue)**
 - Nearly 30 seconds reduction in travel time (~10%)
 - Average speed increased by nearly 7 mph (~13%)
 - Throughput increased by nearly 900 vehicles (~8 %)

36

I-70 Mountain Corridor Incident Management: A Case Study

- **Benefits**

- Over 32,000 vehicles provided with en-route incident information
- Percent of traffic reduction attributable to traveler information on I-70 at Idaho Springs: 20%
- Total delay averted: 2,799 vehicle hours
- Average delay avoided per vehicle: 1.4 hours
- Savings of time to drivers: Over \$40,000

37

SUMMARY OF PROCEEDINGS
2008 NATIONAL PEER EXCHANGE
TRAFFIC OPERATIONS ASSET MANAGEMENT SYSTEMS (TOAMS)

APPENDIX 10

**CASE STUDY VIRGINIA DEPARTMENT OF TRANSPORTATION:
JEFF PRICE**



TOAMS - Case Study

Jeff Price

TRB Peer Exchange – Transportation Operations Asset Management Systems
Milwaukee, WI

April 22, 2008



VDOT System Operations Is A Performance Based Program

Maintenance targets physical condition and asset preservation





- Pavement repairs
- Bridge deck maintenance
- Guard rail repair
- Drainage

Operations targets safety and mobility

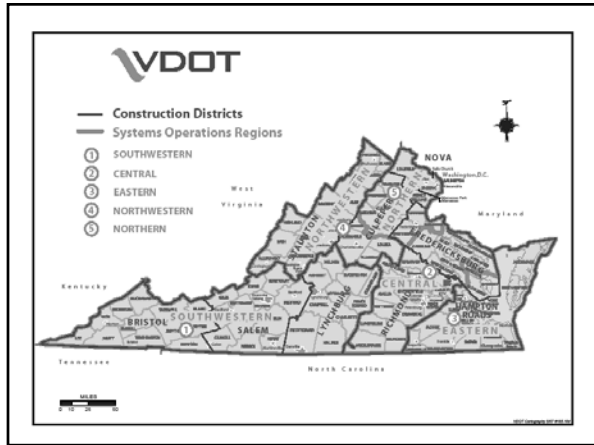

- Traffic signal timing
- Facility Operations
- Incident/Emergency response
- Rest areas

Delivered through Projects and Services

Statewide Operations Asset Inventory

Traffic Management Centers	5
Signals	2833
Callbox	28
CCTV	372
Continuous Count Stations	320
Fog Detectors	2
Highway Advisory Radio	33
HOV Gates	30
License Plate Readers	24
RWIS/ SmartRWIS	52
Traffic Sensors	1416
Dynamic Message Signs	617
Lane Use Signals	520
River/Mountain Tunnels	6
Ferries (routes)	4
Safety Rest Areas/ Welcome Centers	52

VDOT

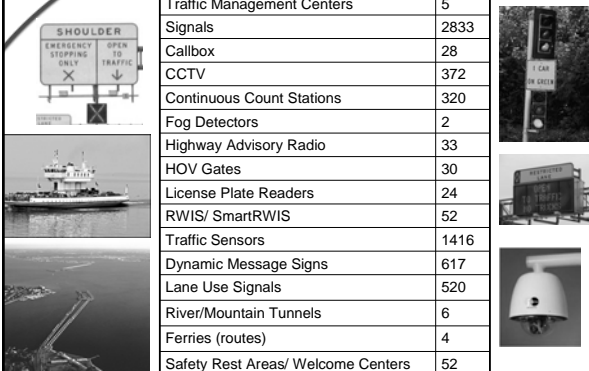
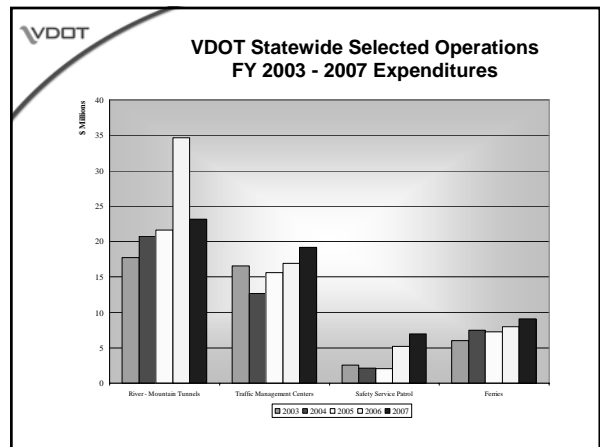
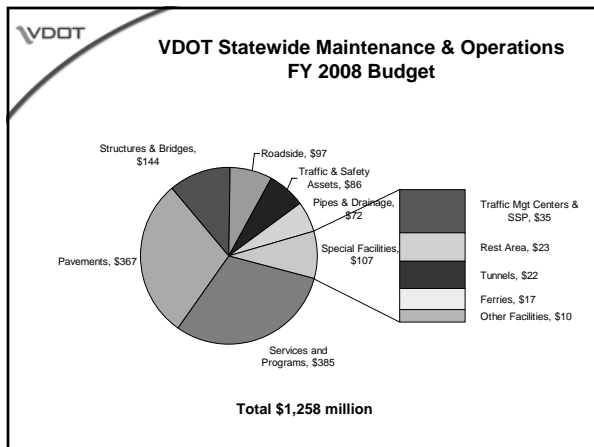
Why is Operations Asset Maintenance Important?

Disruptions in the performance of assets reduces the ability of the TMC to function

- Loss in system capacity
- Increased safety risk
- Congestion and economic loss
- Public may lose faith in the value of ITS program and investments
- EROC chart:

Current Field Device Operational Availability*

Component	Total	Not Working	Working	System Availability
CCTV	199	0	199	100%
CMS	168	18	150	89%
GATES	5	0	5	100%
HAR	6	0	6	100%
DET***	171	18	153	89%

* Represents last weeks equipment availability as of Friday @ 1400
 ** Represents CMS signs with legibility limitations
 *** Represents individual detector stations

VDOT

Operations Asset Maintenance Approaches

- Schedule based
 - Scheduled Preventive Maintenance
 - Predictive failure response
- Performance based
 - Life cycle cost analysis
 - Expected remaining service life
 - Reliability requirements
 - Map needs to Concept of Operations
- Real Time performance monitoring
 - Emergency/Responsive to system monitors

VDOT

Methods Used For Statewide ITS Budgeting

Categories Assessed:

- Ordinary maintenance
- Preventative/Corrective maintenance
- Maintenance Replacement
- Operations – power, communications, operators
- Operational improvement – new installations

Methods:

- Schedule based with life cycle replacement – signals, cameras, dynamic message signs, count stations, traffic sensors,
- Historic expenditures – gates, RWIS, fog detectors, HAR, lighting, lane use signals, call boxes,

VDOT

TOAM Best Practices Include:

- ✓ Track all work/maint. activities – ideally in a Maintenance Management System
 - ✓ NROC uses IMMS, EROC uses MicoMain, others have requested similar systems
 - ✗ No source of statewide data for planning & budgeting
- ✓ Develop and maintain component/parts inventory with cost database
 - ✓ All 5 Regions have this in one form or another
 - ✗ No source of statewide data for planning & budgeting
- ✓ Analyze staffing requirements
 - ✓ NROC and EROC systems include work flow mgt with staffing component

VDOT

TOAM Best Practices Include:

- ✓ Develop a TOAM training program
 - ✓ Each Region has, to some extent
 - ✗ No statewide TOAM training program
- ✓ Develop a maintenance prioritization process
 - ✓ NROC and EROC have formal processes
 - ✗ Statewide Long Range Plan will address prioritization
 - ✗ Develop and maintain ITS architecture and standards
 - ✗ Standards exist to some extent in each Region, but statewide architecture and standards are not yet fully developed or adopted
- ✓ Verify and validate data and systems
 - ✓ Regions validate their data in their systems
 - ✗ Effort underway to establish statewide data and system requirements

VDOT

TOAM Best Practices Include:

- ✓ Inventory by asset or major component
 - ✓ Nearly all VDOT operations asset inventory is geo-referenced by each Region
 - ✗ No statewide source of geo-referenced inventory data
- ✓ Scheduled preventative maintenance
 - ✓ Each Region manages its own PM schedule
 - ✗ Statewide PM policies and schedules not developed
- ✓ Predicted corrective maintenance
 - ✓ Regions have good idea how much CM will be needed
 - ✗ Budget planning for some assets is based on historic expenditures not predicted completions

VDOT

Things to Consider When Planning

- Account for maintenance and replacement cost when planning new installations
- Define measures and targets to meet operational goals
- Account for special equipment and skills needed
- Design data and systems that link maintenance and operations



VDOT

Things to Consider: Procuring Maintenance Services

- Recruiting personnel with right skills and experience
 - Electricians, communications, and computer specialists needed
 - May require different salaries
 - Existing skills and staff in house?
 - Salary or hiring restrictions may make it easier to hire contractor
- Use In-House staff or Outsource?
 - Still need knowledge within the agency
 - Agency supplied equipment?
 - Right people available to manage a contractor?
 - Are maintenance and performance expectations clearly specified in the contract?
 - Require recordkeeping – inventory, bar coding, work history

VDOT

Challenges

- Understanding and modeling B/C of maintenance strategies
- Statewide data and methods for:
 - Monitoring performance
 - Assessing needs
 - Securing funding for ITS maintenance
- Assigning responsibilities
- Developing policies and procedures
- Deciding whether & what to outsource
- Staffing and training
- Integration of data from many sources
- Automating performance monitoring

VDOT

Inventory Management

- Geo-referenced – Know what you have and where it is
 - Determine level of detail needed to assess needs, plan, budget and manage each asset
 - Track where parts reside
 - Bar coding makes event tracking easier
- Track all repair and replacement work on each asset
 - How does the inventory size and condition change over time?
 - Used as input to modeling impact of PM, determining unit costs, warranties, and planned obsolescence and replacement
- Business Process for taking in new inventory and keeping records on existing inventory
 - How is inventory data created, verified, and edited?
 - What is the Change Management process for data?

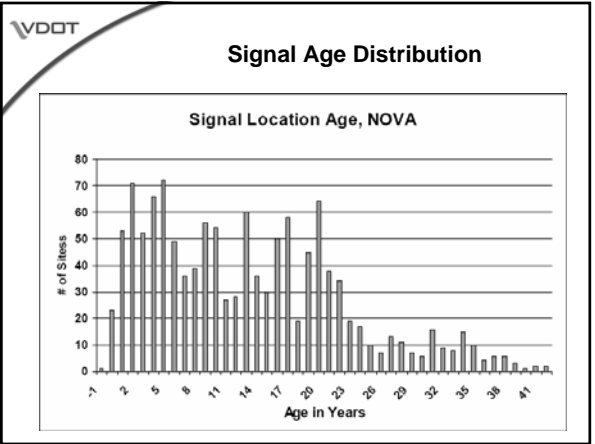
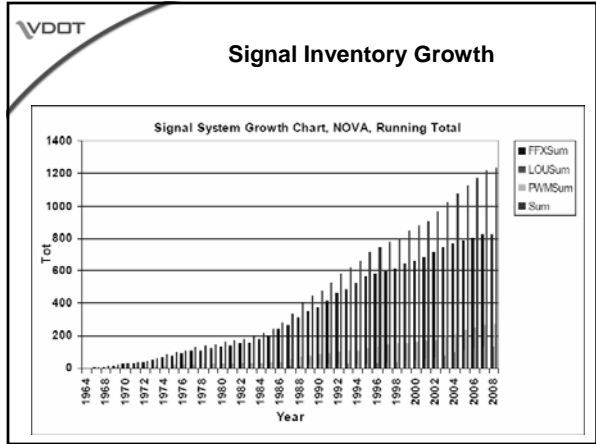

VDOT

Performance Monitoring

- Determine performance metrics and business processes based on Concept of Maintenance
- Document data flow, meta-data, and system requirements
- Build or buy system with specified requirements
- Implement, verify, validate

VDOT

Operations Asset Performance Measures

- Number of field device repairs made by type of repair
- Field device operational availability
- Mean time between failure (MTBF)
- Mean time to repair (MTTR)
- % of priority 1 and 2 repairs made within time targets
- Number of trouble calls; Number of trouble calls requiring OT
- Total maintenance response OT hours and OT cost
- System communication reliability
- Total cost to maintain system by asset, by location

VDOT

Display Examples:

Average Corrective Repair Duration

Asset Type	2006	2007
DET	13	18
HR	18	22
BLDG	43	52
HR	43	52
HR	18	22
HR	18	22
HR	18	22
HR	18	22
HR	18	22
HR	18	22
HR	18	22

Average Maintenance Times by Priority (in hours) Eastern Region

Priority	2006	2007
Priority 1 (within 4 hrs)	~2	~3
Priority 2 (within 24 hrs)	~8	~10
Priority 3 (within 72 hrs)	~18	~25

Number of PM Repairs Made by Equipment Type

Type	56 Week Average
CCTV	3.2
CMS	6.6
GATES	0.5
HAR	1.4
DET	12.1
BLDG	4.0

% of Repairs Completed Within Timeframes

Timeframe	2006	2007
% of Priority 1 Repairs Completed in Less Than 4 Hours	~85%	~90%
% of Priority 2 Repairs Completed in Less Than 24 Hours	~75%	~80%

*PMs for the category of "DET" are for Detector Cabinets, not Detector Stations

VDOT

TOAM System Requirements

- Allow dynamic link to a Data Store to push or pull information
 - Geo-referenced asset inventory
 - Work history with labor, equipment, materials, hours, costs
 - Condition/performance history
 - Projects, budgets, traffic, incidents, weather
- Provide real-time view of system status
- Allow data entry by multiple parties – in house and contractors using hand held devices if desired
- Analytical capabilities- i.e. root cause analysis, impact of asset down time on delay and safety; life cycle cost, impact of PMs on reliability, etc..
- Enable work flow management- i.e. requests, tickets, resources
- Planning and budgeting tools
- Powerful reporting capabilities – queries, charts, graphics, etc..

VDOT

Biggest Issues Currently

- Lack of statewide approach
- Lack of integration with device monitoring systems
- Old practices entrenched – lack of appreciation for PM
- Better methods to estimate B/C of assets and operations
- System design consistency and compatibility
- Lack of data standards and consistent use
- Lack of field tools to support data acquisition

VDOT

Thank you

SUMMARY OF PROCEEDINGS
2008 NATIONAL PEER EXCHANGE
TRAFFIC OPERATIONS ASSET MANAGEMENT SYSTEMS (TOAMS)

APPENDIX 11

**PRESENTATION ON OBSOLESCENCE PLANNING:
TERESA M. ADAMS**

Obsolence

Teresa Adams
University of Wisconsin-Madison

Obsolence

- Condition of being antiquated, old-fashioned, or out-of-date
- Inability to meet performance requirements or expectations that are changing

Factors Causing Obsolence

- Technological change
- Regulatory changes
- Economic / social changes
- Value / behavioral changes

Source: Lemer, A.C. (1996) "Infrastructure Obsolence and Design Service Life." *J. of Infrastructure systems*. Vol. 2 No. 4.

Characterizing Obsolence

- Performance
 - Effectiveness, reliability, and cost
- Failure
 - When performance fall below unacceptable levels
- Failure through obsolence
 - Higher expectations occur due to newer facilities/products, and increased experience

Physical vs. Service Lives

- Physical Lives: time it takes for infrastructure to wear out/fail
 - Predicting this may be irrelevant
- Service life: time actually used

General Representation of Performance and Service Life

The graph plots Performance (P) on the vertical axis against Time (t) on the horizontal axis. The curve begins with a vertical rise labeled 'commissioning'. It then levels off at a high performance level, labeled 'optimum performance'. This is followed by a gradual decline, and finally a sharp drop-off. A horizontal dashed line represents the 'minimum acceptable performance' level. The time interval from the start of the sharp decline to the point where performance reaches the minimum acceptable level is marked as 'design service life (T^D)'.

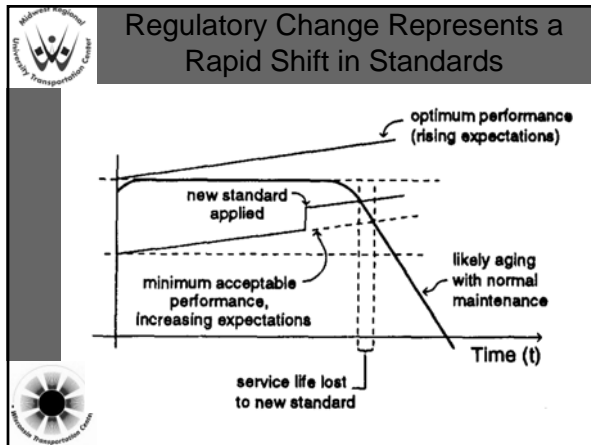
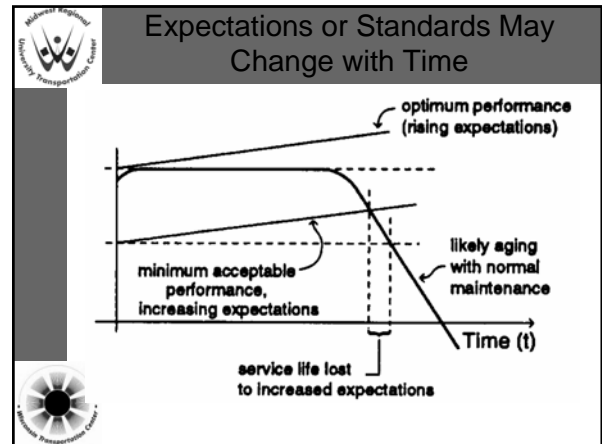
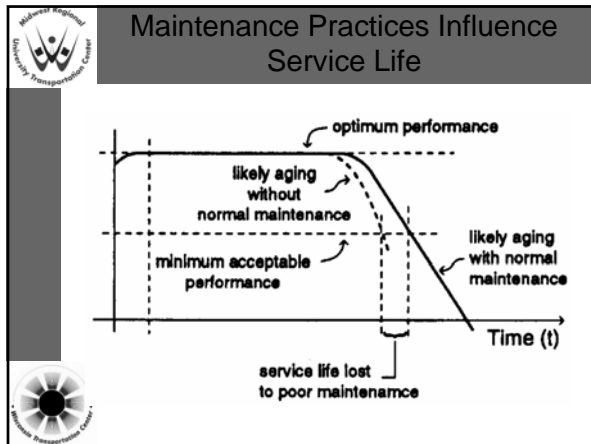

- ### Obsolescence & Service Life
- Long service lives make the spread of technological innovation a slow process
 - Short service lives may lead to reduced reliability and physical life (planned obsolescence)

- ### Strategies to Delay Obsolescence
- Plan and design for flexibility to respond to obsolescence-inducing change
 - Construct to assure the system does not fall short of required performance
 - Monitor change during operations and maintenance and act to slow degradation
 - Refurbish and retrofit early to accommodate change

SUMMARY OF PROCEEDINGS
2008 NATIONAL PEER EXCHANGE
TRAFFIC OPERATIONS ASSET MANAGEMENT SYSTEMS (TOAMS)

APPENDIX 12

**PRESENTATION ON MAINTENANCE CONTRACTING:
FELIX ZAMBRANO**

CALIFORNIA DEPARTMENT OF TRANSPORTATION

TRANSPORTATION SYSTEM MANAGEMENT

DIVISION OF MAINTENANCE
STEVE TAKIGAWA – DIVISION CHIEF

DIVISION OF RESEARCH AND INOVATION
LARRY ORCUTT – DIVISION CHIEF

OFFICE OF RADIO COMMUNICATIONS
FERDINAND MILANES – OFFICE CHIEF

PRESENTED BY
Felix Zambrano, PE

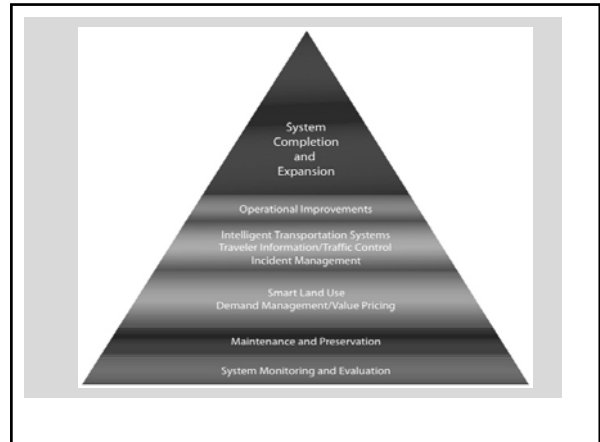

Governor Schwarzenegger's Strategic Growth Plan

- **Proposition 1B** (\$19.9 billion)
Highway Safety, Traffic Reduction, Air Quality, and Port Security
- **Corridor Mobility Improvement Account** (\$4.5 billion)
- Established requirement for corridor system management plans to preserve mobility gains



Caltrans Regional TMCs

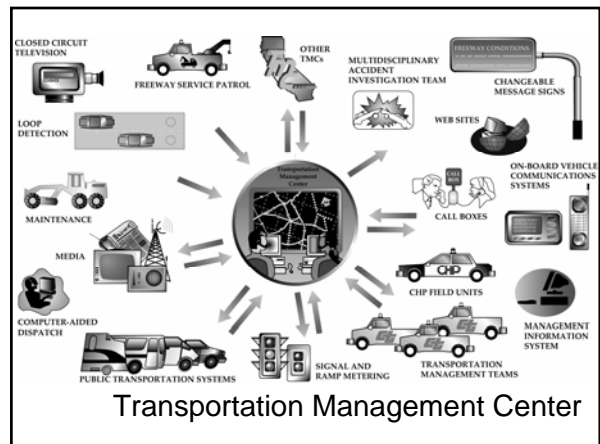

TMS Elements:	Existing (Total)	Planned	Existing + Planned
CCTV	1448	1714	3162
Fixed CMS	672	573	1245
Fixed HAR	131	151	282
Weather Information System	151	164	315
Fiber Optic Comm (Miles)	799	1788.9	2587.9
Metered Ramp Locations (Total)	2261	1670	3931
Ramp Meters (Operational)	2019	-----	-----
Ramp Meters (Non-Operational)	240	-----	-----
Detection (cabinet) Total	4158	4338	8496
Detection: mainline with meters	2248	1670	3918
Detection: mainline only	1910	2668	4578
Census Stations	524	-----	-----

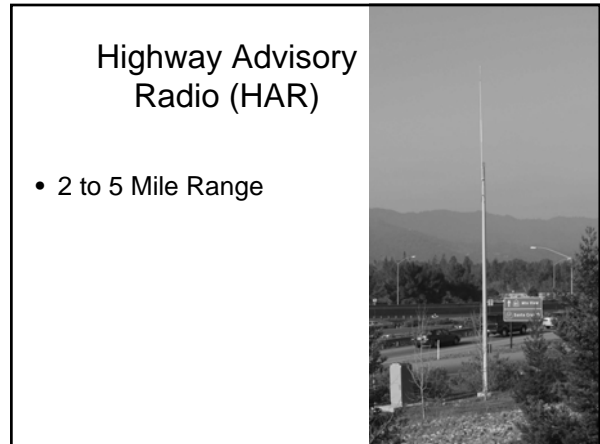
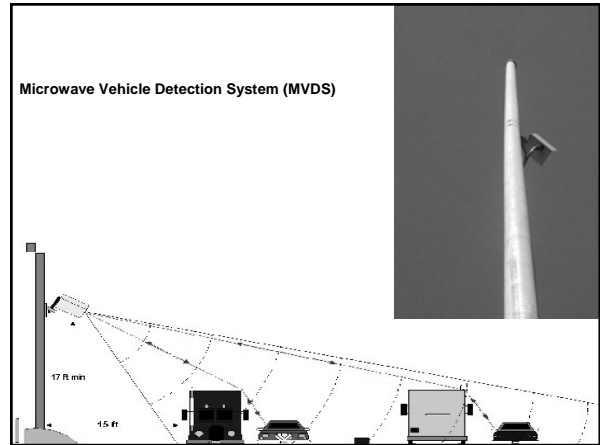
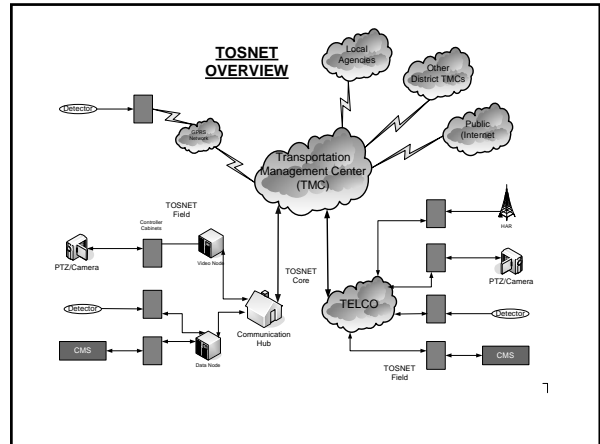



Ramp Metering Strategies

- Maintain Freeway at Maximum Performance
- HOV Incentives
- Break up platoons
- Make merging safer

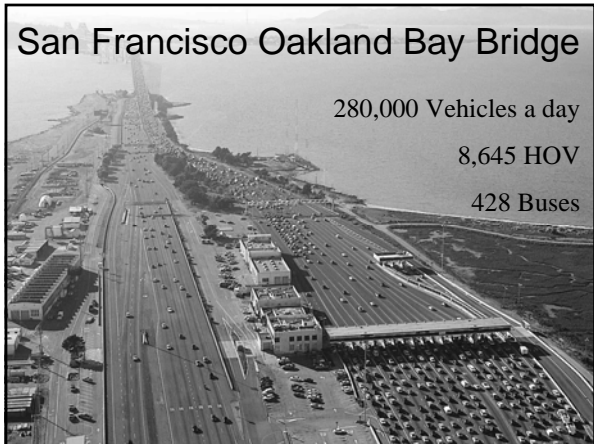
CALTRANS TOSNET Contract Services

Background:

- TOSNET – Traffic Operations System Network
- Started in FY 98/99 with \$4.5 million budget
- Originally administered by Traffic Ops
- Transitioned to HQ Maintenance Division beginning FY2006
- Currently serves districts 3,4,6,7,8,10,11 and 12

TOSNET Contract Types

- TOSNET Repair Maintenance Contract:
 - 24 x 7 on-call hourly rate agreement to repair and maintain the communication infrastructure, network systems and all associated equipment that comprise the Traffic Operations System Network (TOSNET)
 - Multi-year award contract (3 years). One contract for each of Caltrans' districts 3,4,6,7,8,9,10,11 and 12. Managed by the designated district Maintenance Contract Manager (MCM) who issues work orders to the Contractor
 - Traffic Ops create Trouble/Repair tickets then provide a prioritized list to district MCM
 - Regional TOSNET Coordinator (RTC) administers the implementation of the contract and act as the liaison between the district MCM, Traffic Ops and the Contractor
 - Contractor provides journeyman Telecommunications Technicians who are paid in accordance with the State general prevailing wage rate.

TONET Contract types (continued)

- Fiber and Copper Cable Plant Restoration contract:
 - 24 x 7 on-call or as needed basis agreement to repair, restore and test major breaks or damage to the State owned Fiber and Copper outside cable plants
 - 2-year contract. One statewide contract for all 12 districts.
- Hub or Controlled Environmental Vaults (CEVs) contract:
 - Contractor provides corrective and preventive facility type maintenance to TMS communication hubs or CEVs
 - Electrician – Inside wireman is the prevailing wage classification required for this contract

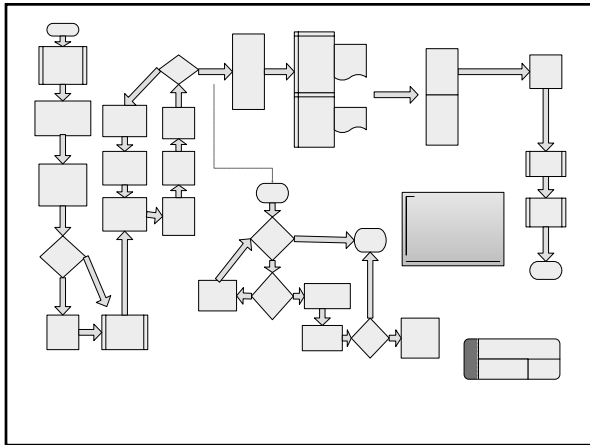

TOSNET REPAIR/TROUBLE TICKET TRACKING SOFTWARES



View Existing Tickets (In Progress)

TICKET ID	REQUESTOR	ISSUE	Element ID	Additional INFO	PRIORITY
20080305-002	Lang, Tyler	DETMS	TM-037	Design spread sheet and begin taking cabinet inventories	Medium
20080410-001	Lang, Tyler	DIRMS	RM-223	Begin installing 7.21 chips into ramp meter locations on 168 and 180	Medium
20080408-003	De Alba, Jose	CCTV	CC-023	Upgrade line and equipment for Telepacific	High

(TC)
Close
Trouble
Ticket

(MCM/TC)
Complete/
Close Work
Order forrr

Records 1 to 3 of 3

(TC)
ID Tosnet links for
repair, prioritize and
issue repair list to
MCM

(TC/MCM)
Notify MCM that
link is not working

(TC/MCM)
Test and
Confirm link
operation

(MCM)
Receive prioritized
repair list
And identify repeat
or recurring
problems

(MCM)
Notify TC that
work is no
complete

(MCM)
Contact TC
to test link
operation

(TC)
Execute Work
Order

(TC)
Notify MCM
after Work
Order is

TC prepares
monthly
Invoices and
send copies
to MCM and
RTC

Monthly
Invoices

Review
Monthly
Invoices and
Complete
Work
Orders

(AP)
Process
Payment

Start QA
Process

Acronyms

TC – Traffic Operations
TMC – Traffic Management Center

SCC
(State
Controller
Office)

Caltrans Questions and Issues

- TMS field elements reached End-of-Life (EOL)
 - Replacement funding source: Capital or Maintenance?
 - Need to know how other States are dealing with this issue
- Electrician retention or hiring problem
 - Can't compete with private salaries
 - Qualification standard
- Standardized Trouble/Repair ticket tracking system
 - Do other states have a unified Maintenance management system that manages both State staff and Contractor work order and performance measurement?

Caltrans Questions and Issues (continued)

- Performance Measurement tools
- Defining Traffic Ops and Maintenance Roles
- Training Electrical maintenance staff on how to maintain and/or troubleshoot/repair new technology communication and TMS equipment

