

THE THERMAL CONDUCTIVITY OF BISMUTH IN TRANSVERSE MAGNETIC
FIELDS, AT LOW TEMPERATURES

A thesis submitted to the Graduate School of
the University of Wisconsin in partial fulfill-
ment of the requirements for the degree of Doctor
of Philosophy.

by

Edwin John Knapp

Date. August 7, 1930

403875

FEB - 3 1934

~~IWX~~~~K727~~

AW

K7272

#4628130

THE THERMAL CONDUCTIVITY OF BISMUTH IN TRANSVERSE MAGNETIC
FIELDS, AT LOW TEMPERATURES

INTRODUCTION

The effect of a transverse magnetic field on the thermal conductivity of bismuth has been investigated several times. Righi¹ and Leduc² found that the conductivity decreases, Nernst could find no change, von Etingshausen³ found decreases of 2 to 5 percent with fields of 9000 gauss, Blyth⁴ found a decrease of 1/2 percent, Ward⁵ also found the effect to be very small. Because the effect does not reverse when the field is reversed, it has often been concluded that the change in thermal conductivity is proportional to the square of the field strength, but Kapitza⁶ shows that such a conclusion may be wrong. Livens,⁷ following the free electron theory of conduction developed by Drude and Lorentz, concluded that the effect is proportional to the square of the field strength and that the field should increase the conductivity. An increase has never been observed. Sommerfeld,⁸ Bloch,⁹ and others¹⁰ have applied the Fermi-Dirac statistics to the old Drude-Lorentz theory, but as yet the new statistics have not been applied to exactly this problem.

Since the effect of a magnetic field on the electrical conductivity is very much greater at low temperatures than it

is at room temperature and since electrical conduction and thermal conduction are so closely related, the author felt that at low temperatures the effect of a magnetic field on the thermal conductivity of bismuth might be large enough to be determined with more accuracy so that its variation with field strength could be observed. The work here described has confirmed this expectation.

APPARATUS

Many of the most approved methods of measuring thermal conductivity require apparatus too bulky to fit in the limited space between the pole pieces of an electromagnet, so it was decided to eliminate heat losses by evacuating the space about the specimen and the heat source.¹¹ Thus condensation of water from the atmosphere on the cold parts of the apparatus was also avoided. The apparatus is shown in Fig. 1. The entire case containing the specimen was made of brass. The parts of the upper half including the threaded disc were soldered together; then the lower half was assembled in the same way. The specimen, B, was produced by casting the bismuth in a Pyrex tube in which the pressure was 10^{-3} mm of mercury. The casting was removed by filing and cracking the glass. It was then turned to the desired dimensions (11 mm in length and 8.70 mm in diameter). The castings were found to be composed of large crystals, a single crystal face often covering about one-half of the area of cross-section. Due to the size of these crystals and to the ease of cleavage along the principal cleavage

plane, it is easy to tear a part of the crystal from the specimen if too deep a cut is taken in turning the bismuth. This material may be machined very beautifully by taking a light cut. The specimen was fixed to two copper cylinders, c and c', with Wood's metal, the Wood's metal being first carefully worked over the surface of the copper. The upper end of c' was shaped so that it would come into good contact with the disc d, when c' was firmly screwed into d. A heating coil, H, of #28 "Therlo" wire was wound directly on c and glued to it with shellac. Two or three coats of shellac, baked on, held the heating turns very firmly to c. The leads to the heater were #22 copper wires. The wires composing a thermocouple were spot-welded together and three different ways of attaching them to the specimens have been used at different times:

(A) Holes 0.5 mm in diameter and 0.51 cm apart were drilled into the bismuth cylinder, care being taken to have the line joining the two holes as nearly parallel to the axis of the specimen as possible. Each junction was then inserted into its hole and a short length of copper wire which fitted the hole snugly was covered with shellac and inserted so as to press the junction firmly to the bismuth.

(A') Each junction was covered with a small bead of solder which did not quite fill the hole in the bismuth. Then these beads were coated with thin layers of melted shellac and fastened into the holes with ordinary shellac, and in later trials, with soft wax. Thus the junctions were insulated electrically from the specimen.

(B) A small hole was drilled 1.5 mm below the upper surface of c and another 1.5 mm above the lower surface of c'. The junctions were then soldered into these holes in the copper cylinders.

At first, copper-constantin couples of about #30 wire were used, but these were discarded because it was found that the thermo-electromotive force of copper-constantin is influenced by the magnetic field. This effect has long been known to exist in couples in which wires of iron, nickel, or cobalt were used,¹² but it was not known that the magnitude of the effect in constantin would be great enough to prohibit its use in the present work. The author could find no data on the influence of magnetic fields on the thermo-electromotive force of couples employing constantin. It may be true that at the higher temperatures at which previous work on the effect of magnetic fields on thermal conductivity was done by others, this change of thermo-electromotive force with magnetization is smaller than it is at the temperatures used in the present work. Some of the investigators mentioned previously used copper-constantin, but none of them mention this difficulty.

In all the work here reported on, platinum-palladium couples were used and it was found that the magnetic field did not alter their thermoelectric power. These wires were 0.08 mm in diameter. The thermocouples used were calibrated by comparison with a pentane thermometer certified by the U.S. Bureau of Standards. To insulate the thermocouple wires, short

lengths of very small glass tubing were strung on each wire. A thread running along these beads and fixed to each one was fastened to the brass wire, w, projecting from c'. This thread supported the slight weight of the glass and permitted the leads subsequently to be pulled through the brass tube, t, without injury to the junctions. The specimen, with the cylinders c and c' fixed to it was then screwed firmly into the disc w. The leads were then drawn through t and out through the wax seals. The joint, n, had to be quite carefully soldered with Wood's metal. Very little difficulty was encountered in attaining pressures of 10^{-6} mm of mercury in spite of the fact that the apparatus was assembled twelve to fifteen times due to other difficulties.

RESULTS

The conductivity, k, was determined in fields ranging from zero to 11,100 gauss. The average temperature, when the field is applied, is not the same as it is with no field, so that a part of the change in conductivity observed when the field is applied will be due to the change in the average temperature of the specimen. To get the change in conductivity which is due to the field alone, the author's values of k with no field are plotted to large scale as a function of temperature, Fig. 3, and the value of k_0 , the conductivity with no field at the temperatures obtaining when the field is present, is taken from this graph. Then the relative decrease in conductivity due to the magnetic field is calculated from the relation,

$$(1) \quad \frac{\Delta k}{k_0} = \frac{k_0 - k_H}{k_0}$$

in which k_0 is the conductivity in the absence of the field and k_H the conductivity when the field is applied.

The author's values of k and of $\frac{\Delta k}{k_0}$, calculated from (1), are given in Table 1. Fig. 2 is plotted only to show how the author's values of the conductivity, with no applied field, compare with those of previous workers. In Fig. 4, $\frac{\Delta k}{k_0}$ is plotted as a function of the field strength.

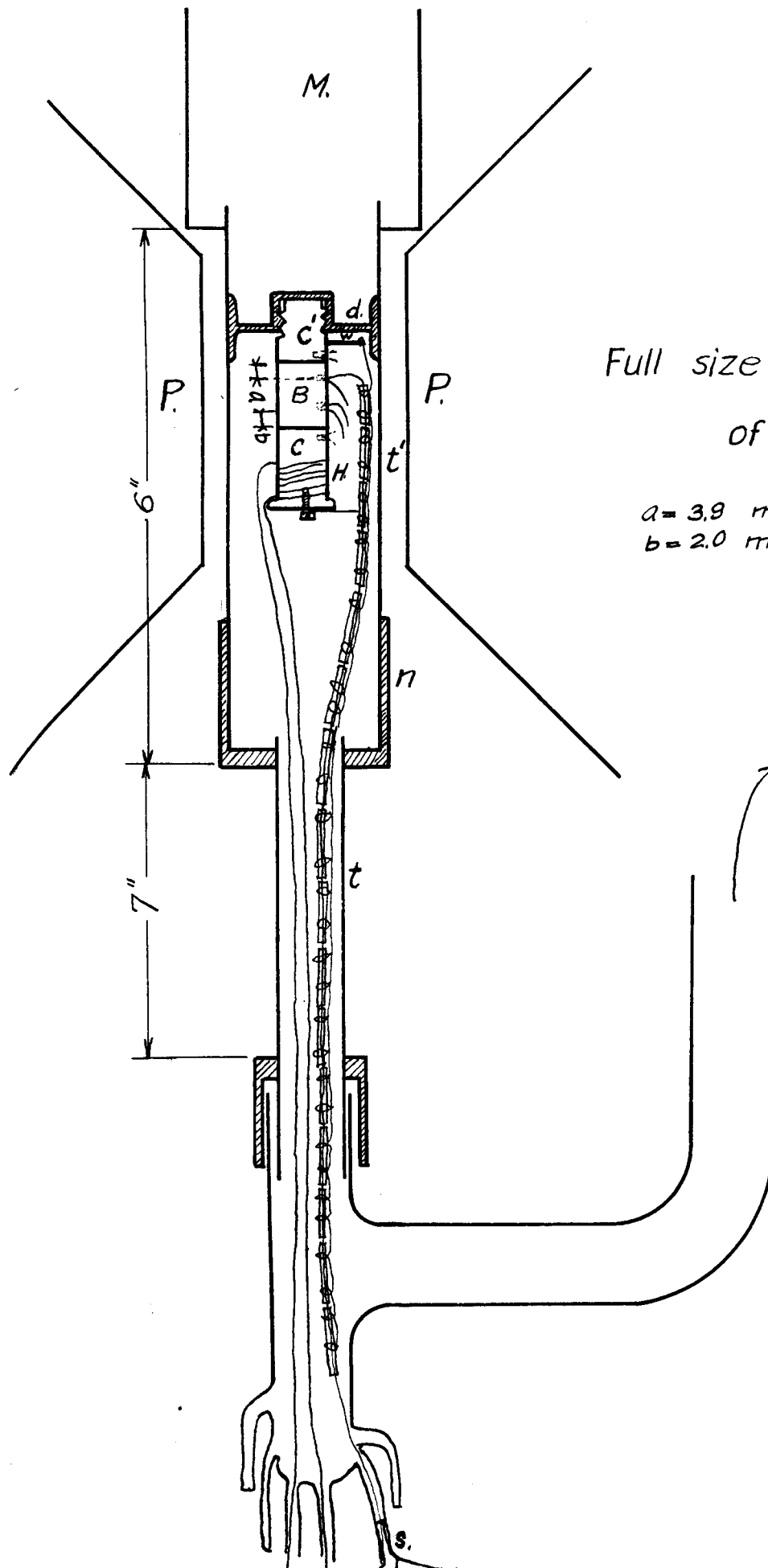

FIG. 1

Full size excepting lengths
of t and t' .

$a = 3.9$ mm.
 $b = 2.0$ mm.

To pumps
and gauge.

TABLE I

	H	E	I	T ₁	T ₂	T ₂ -T ₁	T _a	k	k ₀	$\frac{\Delta k}{k_0}$
1	0	2.46	0.77	-156.7	-146.4	10.3	-151.0	.0387		
2	0	2.46	0.77	-161.0	-151.0	10.7	-166.0	.0372		
3	0	2.46	0.77	-148.0	-137.5	10.5	-142.5	.0379		
4	11100	2.46	0.77				-157.0			31.0
5	8400	2.46	0.77				-160.0			28.3
6	0	2.46	0.77	-45.5	-28.0	17.5	-36.7	.0246		
7	0	2.24	1.08	-161.3	-135.5	25.8	-148.4	.0410		
8	8400	2.24	1.08	-161.6	-122.0	39.6	-141.8	.0267	.0384	30.0
9	4450	2.24	1.08	-161.5	-128.0	33.5	-144.7	.0315	.0388	19.3
10	0	1.92	0.94	-166.0	-146.4	19.6	-151.2	.0402		
11	1250	1.92	0.94	-167.0	-145.7	23.1	-156.7	.0370	.0414	10.6
12	4450	1.92	0.94	-167.0	-142.6	24.4	-154.8	.0323	.0410	21.2
13	3250	1.91	0.94	-176.1	-153.2	22.9	-164.6	.0344	.0432	20.3
14	0	1.92	0.94	-176.0	-159.0	17.4	-167.5	.0438		
15	1250	1.91	0.94	-176.4	-156.4	20.0	-166.4	.0394	.0436	9.7
16	0	1.91	0.94	-170.0	-151.5	18.5	-160.7	.0422		
17	11100	1.91	0.94	-171.8	-145.3	26.5	-158.5	.0297	.0418	28.9
18	0	1.92	0.94	-174.3	-156.3	18.0	-165.3	.0432		
19	6400	1.91	0.94	-174.0	-149.6	24.4	-161.8	.0323	.0425	24.0
20	0	2.98	1.46	-152.0	-99.0	53.0	-125.0	.0359		
21	6400	2.97	1.46	-150.8	-83.6	67.2	-117.2	.0279	.0346	19.7
22	11100	2.97	1.45	-150.5	-78.4	72.1	-114.5	.0260	.0342	24.0
23	8400	2.97	1.45	-150.8	-80.6	70.2	-115.7	.0268	.0344	22.0
24	4450	2.96	1.45	-150.5	-87.5	63.0	-119.0	.0298	.0356	16.3
25	0	2.96	1.45	-150.0	-96.5	53.5	-123.2	.0353		
26	1250	2.96	1.45	-149.5	-94.0	55.5	-121.7	.0338	.0351	3.8
27	2250	2.96	1.45	-150.5	-92.0	58.5	-120.5	.0321	.0351	8.6
28	3250	2.96	1.45	-150.8	-90.6	60.2	-120.7	.0312	.0352	11.3
29	5000	2.96	1.45	-151.0	-85.6	65.4	-118.3	.0288	.0348	17.2
30	0	2.96	1.45	-92.0	-38.2	53.8	-65.0	.0338		
31	0	1.65	0.71	+29.0	+47.0	18.0	+38.0	.0232 *		

In the table above,

- H = Magnetic Field Strength.
- E = Voltage applied to Heating Coil.
- I = Current in Heating Coil.
- T₁ = Temperature of Upper Junction.
- T₂ = Temperature of Lower Junction.
- T_a = $\frac{T_1 + T_2}{2}$

k₀ = Thermal Conductivity with no field corresponding to the Temperature at which the Conductivity was determined in the presence of the Field.

$\frac{\Delta k}{k_0}$ = Change in Conductivity (percent) due to field.

*To make this determination, the dup M, Fig. 1, was kept filled with ice and water.

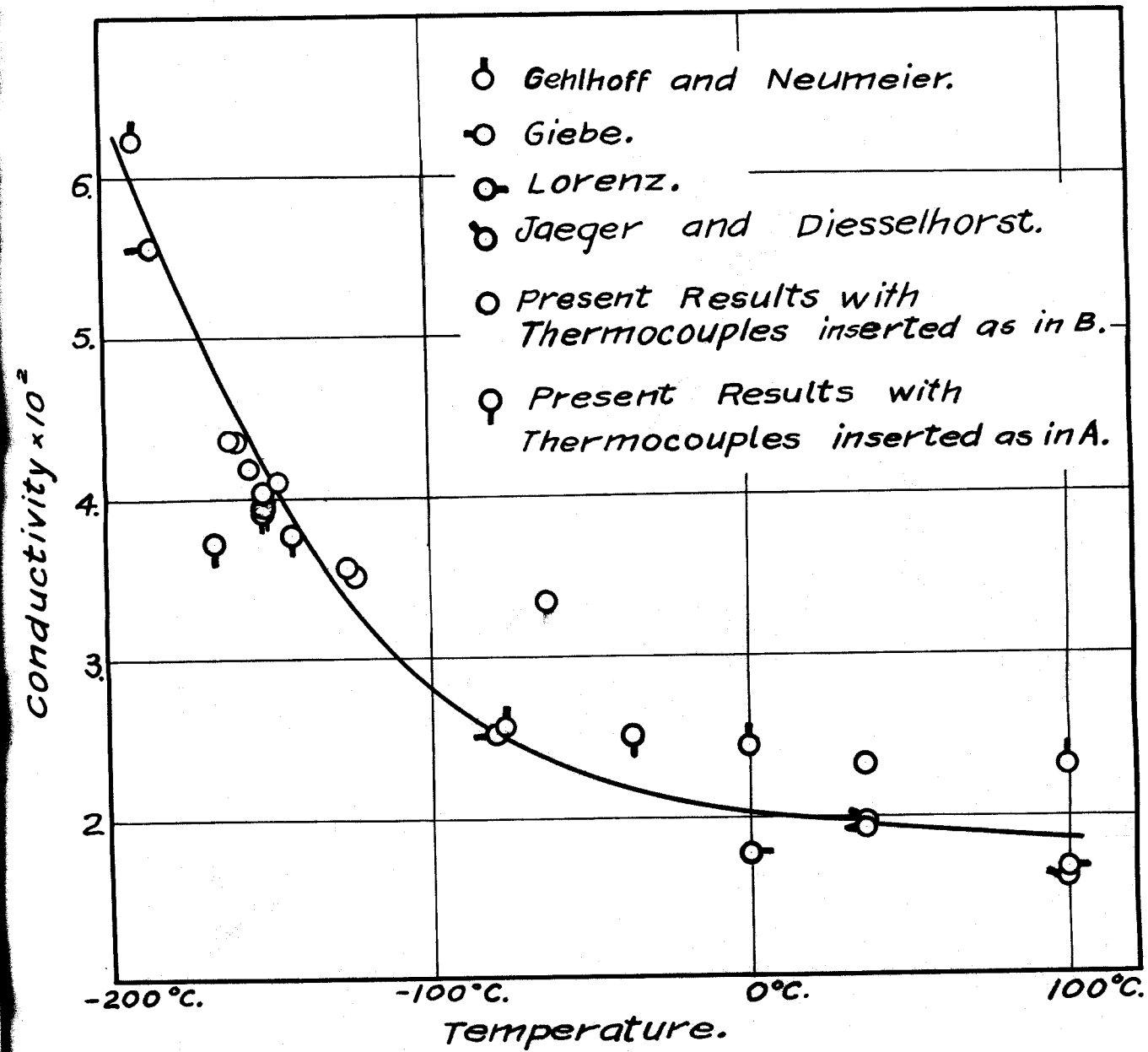

Fig. 2.

UNIVERSITY OF WISCONSIN

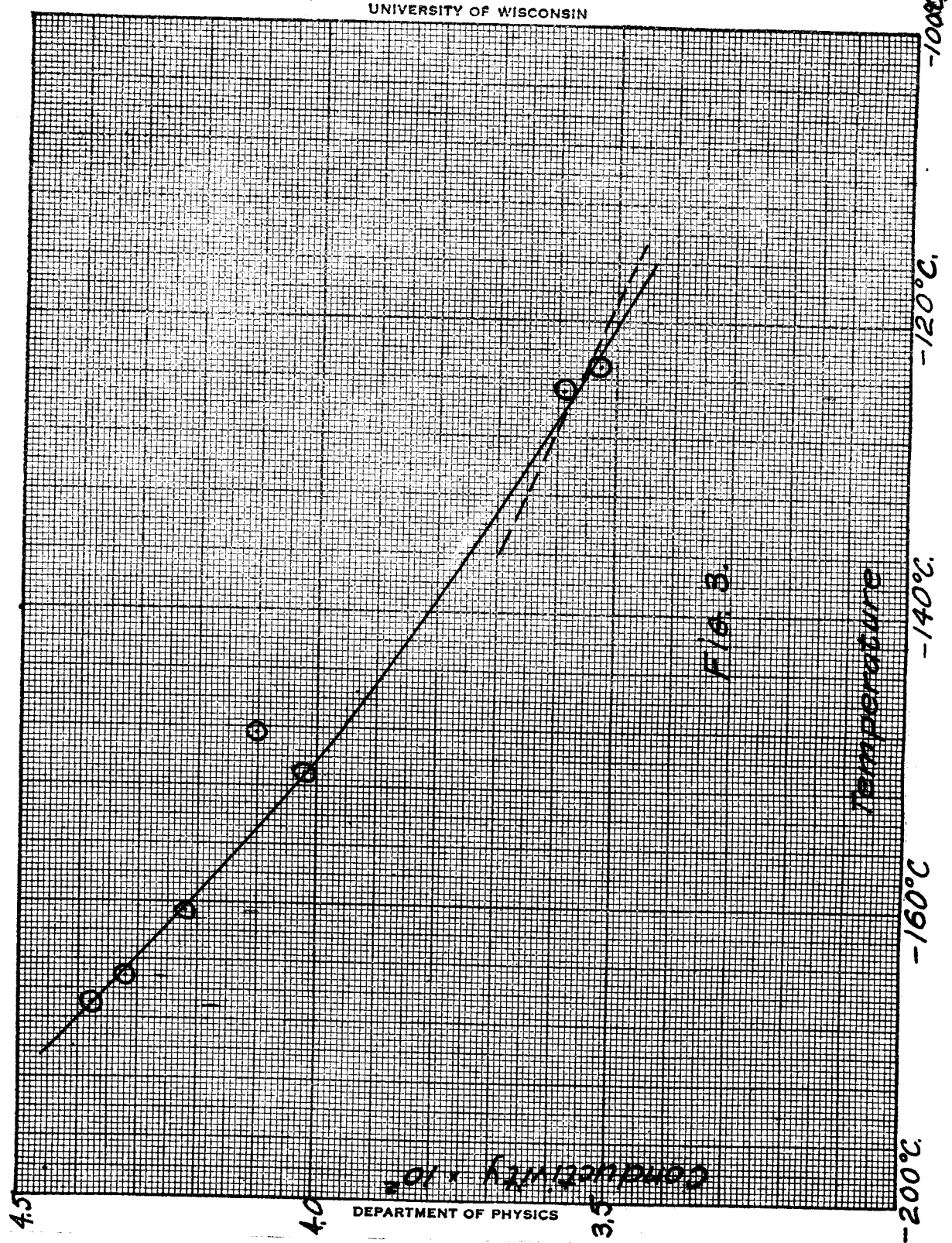
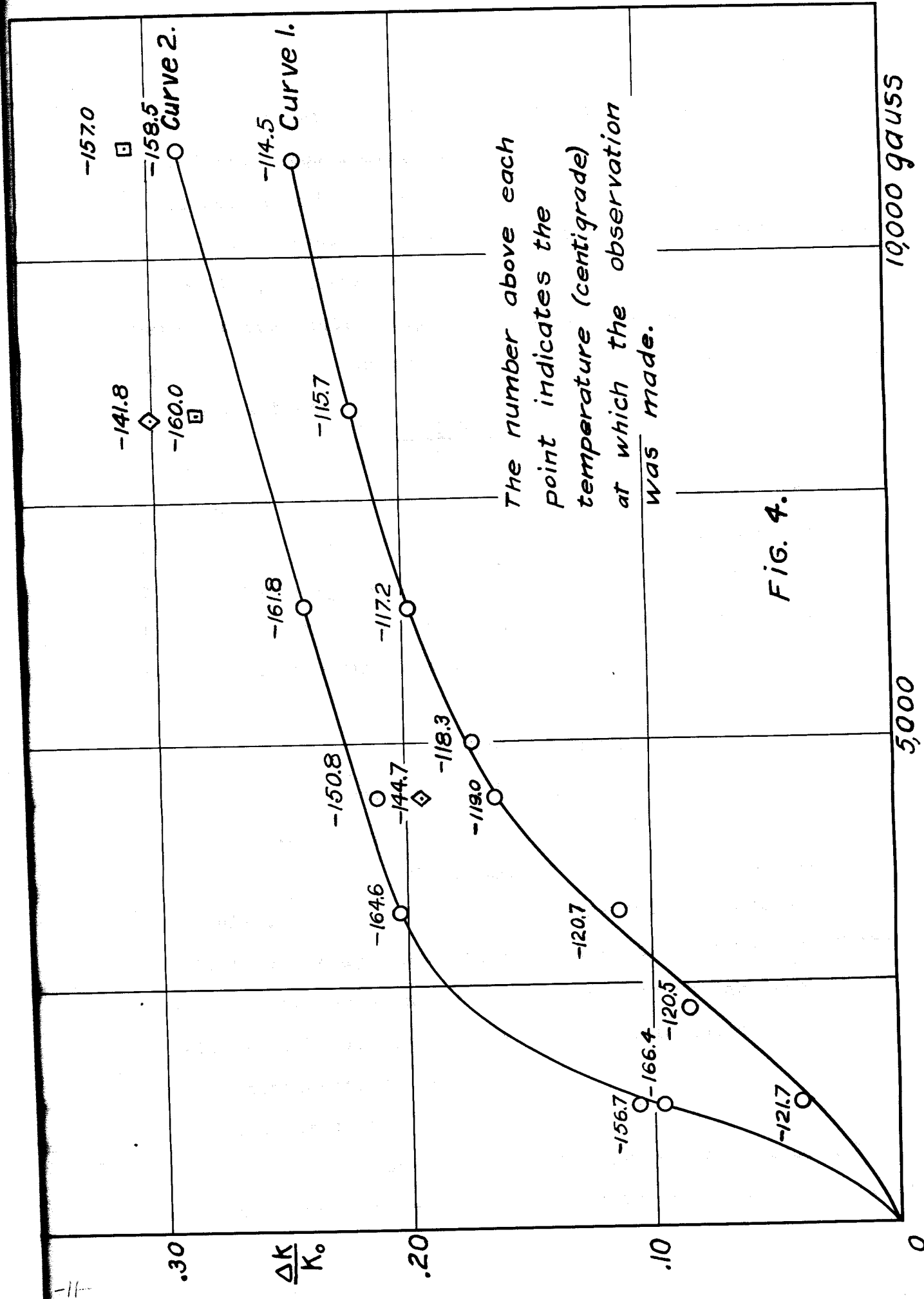

Fig. 3.

DEPARTMENT OF PHYSICS

CONDUCTIVITY x 10⁶

Temperature



The number above each point indicates the temperature (centigrade) at which the observation was made.

FIG. 4.

Magnetic Field Strength.

19000 gauss

5000

To determine the conductivity, the cup M was kept filled with liquid air, air being added about every minute so as to keep nearly the same amount of air in the cup during the complete run. A constant amount of heat was generated in the coil H, and the temperatures registered by the couples were observed until they had remained constant for at least twenty minutes. The conductivity was then calculated by means of the relation,

$$(2) \quad K = \frac{Q L}{A(T_2 - T_1)}$$

K being the conductivity, Q the number of calories per second generated in the heating coil, A the area of cross-section of the specimen, T_2 the temperature at the lower junction, T_1 the temperature at the upper junction, and L the distance between the two junctions.

SOURCES OF ERROR

A. Heat Losses From the Heating Coil.

In calculating the conductivity, with or without the field, by means of the simple relation (2), one assumes that all of the heat generated in the coil is lost by conduction through the specimen. The observed values of the conductivity, both in the presence and in the absence of the field, will be affected by extraneous heat losses. These will now be considered in detail.

1. Convection.

Convection losses may be assumed to be ignorable since a fifty-fold decrease in the pressure (5×10^{-6} to about

10⁻⁷) caused no observable difference in the resulting values of k .

2. Conduction along leads to heating coil.

The errors due to conduction along the leads to the heating coil will affect the author's values of k . Unfortunately, the temperature of the coil is not known so that corrections for conduction along the leads cannot be accurately made, but we can get some idea of the magnitude of the errors thus involved.

First, let us assume that the leads to the heating coil are in contact with the case at a point near to the lower end of t' . To determine the temperature of the lower end of t' (Fig. 1) a copper-constantin thermocouple composed of #24 wires was soldered to a thin 2 x 3 cm sheet of copper, the wires being insulated except over the area in which they were in contact with the small copper sheet. This sheet was then inserted between the case and the lagging covering the case so that the junction was in contact with t' at a point about 2 cm above the lower end of the tube t' . Pressure was then applied on the lagging at this point by means of a small clamp. The temperature of this thermo-junction was found to be -41°C after the cup had been kept full of air for 2 hours. This method of determining the temperature of the lower end of t' was then repeated with a modified thermocouple in which the #24 copper wire of the previous couple was replaced by a #30 copper wire. This modification was introduced to reduce the amount of heat conducted to the junction by its leads and thus

to see if wires composing the thermocouple conducted enough heat to the junction in contact with the case to affect the temperature registered by the couple. The temperature registered by this modified junction, when it was in contact with the case, differed by less than one degree from that recorded by the first couple thus employed.

The distance along the leads from the lower end of t' to the heating coil was about 12 cm. Now we can make corrections (based upon various assumptions as to the temperature of the heater) to the author's values of k.

These corrections to those values of k which are plotted in Fig. 3 are given in Table II.

TABLE II

Input	Ave. Temp. of Specimen	Temp. of c	Temp. of heater	Correction for conduction along leads
1.04 cal/sec	-124°C	-99°C	0° hotter than c	+3.1%
			58° " " "	0%
			120° " " "	-3.4%
0.43 cal/sec	-160°C	-145°C	0° " " "	14%
			50° " " "	7%

Let us next assume that the leads are nowhere in good thermal contact with the case, and in a good vacuum it is very likely true that even if the leads were to touch t there would be very poor thermal contact between the leads and the case. The energy gained by the heating coil due to conduction along the leads would then have to be conducted

along about 30 cm of the leads and the temperature drop along this length of the leads would be about equal to room temperature minus the temperature of the heating coil. Then the required corrections to those values of k which are plotted in Fig. 3 are given in Table III.

TABLE III

Input	Ave. Temp. of Specimen	Temp. of c	Temp. of heater	Correction for conduction along leads
1.04 cal/sec	-124°C	-145°C	0° hotter than c	+1.4%
			120° " " "	0%
			230° " " "	-1.4%
0.43 cal/sec	-124°C	-99°C	0° " " "	+5.2%
			100° " " "	+2.0%

In estimating the corrections given in Table II and Table III, no account was taken of the heat which the leads gain from the case by means of radiation. The leads were covered with cotton insulation and shellac. The emissivity of the surface of this covering was quite high, but the case surrounding the leads was fairly well polished so that there will not be very much radiation loss from the leads. The difference between the temperature of a given point on the lead and that of a nearby point on the case was about zero at the lower end of t . At points above the lower end of t , this difference in temperature will depend upon the temperature of the heating coil which is not known. However, radiation from the leads to the heater will not greatly affect the estimates given in Tables II and III. If one desired to determine

actual values of k , it would be well worth while to reduce the amount of radiation from the leads, but in the present work it is desired only to compare the thermal conductivity of bismuth in the presence of the magnetic field with the thermal conductivity of bismuth in the absence of the field, so it is only necessary that the heat losses from the heating coil be the same with the field on as they are with the field off.

Conduction along the leads thus alters the rate at which heat is given off by the heating coil so that (neglecting the small amount of heat radiated from the leads) a positive correction of not more than 5.2% should be applied to those values of k which were calculated from the data of experiments in which the input was 0.43 cal/sec. With an input of 1.04 cal/sec, the required correction lies between +1.4% and -1.4%. The author's values of k determined at -125°C (input = 1.04 cal/sec) lie quite well on the curve, Fig. 2, and those values of k which were observed at temperatures of from -150°C to -167°C lie somewhat below the curve, Fig. 2. These facts indicate that the limits of the experimental errors due to conduction along the leads are roughly those estimated above if the curve, Fig. 2, represents the true conductivity of the specimen used by the author.

We may note that the temperatures of c , during a given series of experiments (Table I) varies somewhat among successive observations in which a given amount of heat was supplied by means of the heating coil. This variation in the

temperature of c introduces only very slight differences in the corrections to the values of k. Thus the values of k for temperatures between -150°C and -165°C (Fig. 3) will all be shifted upward by nearly the same amount by a positive correction to k. The two values at -125°C will also be equally affected by a correction for conduction along the leads.

3. Radiation losses from the heating coil.

Corrections for radiation, like corrections for conduction along the leads to the heating coil, can be estimated only very roughly since the temperature of the heating coil is not known. Let us consider the case in which radiation losses would be greatest, i.e., the case in which it is assumed that the heater is 230° hotter than c, and let us suppose that the inner surface of the case and also the surface of the heater had an emissivity of about $1/2 \times 10^{-12}$ cal/sec/degree⁴ (i.e., roughly half of the emissivity of a black body):

$$\text{Then temp. of c} = 230^{\circ}\text{C} - 99^{\circ}\text{C} = 131^{\circ}\text{C} = 404^{\circ}\text{ Abs.}$$

$$\text{Ave. temp. of case} = \frac{-180^{\circ}\text{C} - 41^{\circ}\text{C}}{2} = -110^{\circ}\text{C} = 163^{\circ}\text{ Abs.}$$

$$\text{Radiating area of heating coil} = 2 \text{ cm}^2$$

$$\text{Emissivity of surface of heater} = 1/2 \times 10^{-12} \text{ cal/sec.degree}^4$$

Then the rate of loss of heat due to radiation by the heating coil is, in cal/sec,

$$\begin{aligned} q &= 2 \times 1/2 \times 10^{-12} [(400)^4 - (160)^4] \\ &= 2 \times 1/2 \times 10^{-12} [256 \times 10^8 - 6.6 \times 10^8] \\ &= 250 \times 10^{-4} \\ &= .0250 \text{ cal/sec.} \end{aligned}$$

or 2.4% of the input

Since the inner surface of the case is made of brightly polished brass, this estimate is probably too high. Because they increase as the fourth power of the temperature, radiation losses would cause considerable error if the present apparatus were used at higher temperatures.

The apparent error in the author's value of k at -65°C can be attributed to heat losses only if one assumes that the heating coil was several hundred degrees hotter than the cylinder on which it was wound. To determine k at -65°C an auxiliary cup was placed in the upper cup of the apparatus so that the liquid air would not come into contact with the top of the disc d . The temperatures registered by the thermocouples inserted into the cylinders c and c' when the auxiliary cup was used and when a constant amount of heat was generated in the heating coil varied about ten times as much as those observed with the previous experimental conditions, but even so much fluctuation (about 2°C) probably would not account for the entire deviation of this value of k from the mean of the results obtained by previous workers.

If the error due to energy gained by the heating coil by means of radiation and conduction along the leads is the same with the field on as with the field off, and obviously one may assume that this is essentially true, the result sought

$$\frac{\Delta k}{k_0} = \frac{k_0 - k_H}{k_0}$$

(k_0 is the conductivity with no field, k_H the conductivity in

the presence of the magnetic field) is not affected, since the numerator and the denominator would both be affected by the same factor.

The errors due to conduction and to radiation could be reduced and the accuracy with which it is possible to calculate them could be increased by making certain modifications in the apparatus used by the author. If smaller resistance wire of higher specific resistance were used in the heating coil, the resistance of the coil could be increased so that a given amount of heat could be supplied with less current, and the leads to the heater could be reduced in size. In this way, conduction along the leads would be reduced. Another improvement would be to fasten the insulated coil to the cylinder on which it is wound, with Wood's metal, so as to secure good thermal contact between the coil and the cylinder c. If this contact were a good one even when the pressure was reduced to 10^{-6} mm of mercury, one could assume that the temperature of the coil was nearly the same as that recorded by the thermocouple which is inserted into c, and thus one could make corrections for radiation and for conduction along the leads to the heating coil with some degree of accuracy. The use of Wood's metal in this way would reduce radiation losses in two ways. First, it would reduce the difference between the temperature of the heater and that of the cylinder so that the temperature of the radiating surface would be reduced; and second, it would

offer a surface of smaller emissive power. It would also be desirable to silver the cylinder c, and the interior and the exterior surfaces of the case.

B. Lateral Heat Losses.

In the present work, it is especially important to guard against any flow of heat through the exposed (cylindrical) surface of the specimen. Any lateral loss of heat through this surface would distort the flow of heat in the bismuth and thus might alter the effect of the magnetic field upon the latter flow of heat. The author believes that with the present apparatus these heat losses are nearly as small as they can be made. (See discussion of the low temperature experiments of Kannuluik and Laby, l.c.) The agencies which might introduce lateral heat losses from the surface of the specimen will now be considered.

1. Convection.

Convection losses from the exposed surface of the specimen may be considered negligible because of the observations noted on page 12.

2. Radiation.

Energy exchanges (by means of radiation) between the case and the specimen are small because the surface of the specimen is a poor radiator and because the temperature of the case and that of the specimen are both low. The heating coil is somewhat warmer than its surroundings and will radiate to some extent. However, very little of the

energy radiated by the heater would come directly to the specimen, and that which did so would strike the bismuth at almost grazing incidence. Thus we may conclude that the cylindrical surface of the bismuth gains or loses very little heat by means of radiation.

3. Conduction along the thermocouple leads.

Conduction along the thermocouple leads has been reduced by the use of very fine wire (0.08 mm in diameter) in the construction of the thermocouples. It is further reduced by the fact that, from the junction to the wax seals, (a distance of about 30 cm) the thermocouple leads are surrounded by a well evacuated space so that they can gain very little heat along this length.

C. Errors Due to Non-linearity of Conductivity-Temperature Curve, Fig. 3.

The conductivity of bismuth is not a linear function of temperature, so errors are involved:

(a) In considering that the conductivity observed is the actual conductivity at the average temperature of the specimen.

(b) In neglecting the fact that when the magnetic field is applied the temperature range is extended so that the observed conductivity is not exactly the same as it would be if the same average temperature were attained without extending the temperature range.

Since the curvature of the conductivity-temperature graph, Fig. 3, is slight, the errors introduced by (a) and (b)

above are much smaller than the errors due to other causes and will be neglected.

D. Errors Peculiar to the Method of Inserting the Thermocouples.

The above sources of error are common to all the methods, A, A', and B, of fixing the thermocouple to the specimen. Difficulties and sources of error peculiar to the particular method of fixing the thermocouples to the specimen will now be discussed.

When the thermocouples are inserted into the specimen as in method A

(see Fig. 5) the small lengths of copper wire which were inserted into the holes in the bismuth will distort the heat flow in the specimen.

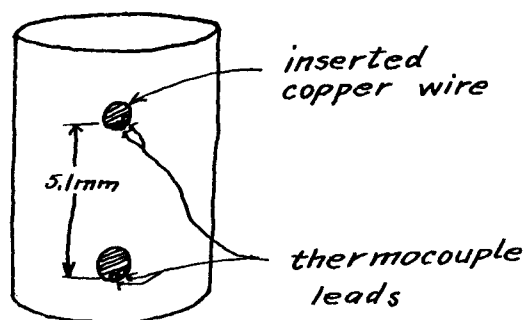

FIG. 5.

Also the diameter of the inserted wire (1/2 mm) is not ignorable in comparison with the distance between the holes (5.1 mm) so one cannot be sure just how great one should consider the separation of the points at which the temperatures have been measured by means of the thermocouples thus inserted. An error of 0.2 mm in the determination of L , equation 2, would cause an error of 4% in the author's values of k_0 and k_H which were observed with the thermocouples

inserted in this way.

With the thermocouples inserted as in A, it was found that the lower thermocouple recorded the same electromotive force regardless of the direction in which the field was applied, but the upper one did not. Subsequent examination showed that the two wires composing the upper thermocouple touched the bismuth at two points, separated longitudinally as well as tangentially. There may also have been a radial separation of the points of contact (i.e., one point of contact may have been closer to the axis of the specimen than the other). Thus extraneous galvanomagnetic effects were introduced. The tangential and the radial separations bring in the Nernst¹³ effect, and the longitudinal separation involves the effect studied by Smith¹⁴ and others (a thermomagnetic longitudinal potential difference). The origin of the effect observed by Smith has not been determined. It may be, ^{partly} *due to* a change of the thermo-electromotive force of junction between the potential lead and the bismuth. The Nernst effect has been found to reverse when the field is reversed, but the longitudinal effect does not. If both effects reversed when the field was reversed, it would be permissible to take the average of the E.M.F. of the junction with the field direct and with the field reversed to obtain the true temperature of the upper junction.

The importance of these extraneous effects is enhanced because it is necessary to avoid the use of thermocouples which are influenced by the magnetic fields. Thus all of the most sensitive thermocouples, since they involve

the use of ferromagnetic materials, must be avoided, and the importance of an extraneous effect is increased by the fact that the thermo-electromotive force of the junction is itself small. The upper couple behaved just as one would expect it to if both of the above effects were present (i.e., a large effect which reverses when the field is reversed and a smaller one which does not). With a constant flow of heat up the bismuth cylinder, the E.M.F. of the upper couple changed very much with reversal of the applied magnetic field, but the average of these two widely divergent readings differed only slightly from the E.M.F. corresponding to the temperature of the junction as obtained by means of the calculation indicated in the following paragraph. The temperature at the upper junction can be directly observed only in the absence of the magnetic field.

To calculate the temperature of this junction when the field is applied, one can assume that with a constant flow of heat up the bismuth cylinder, the temperature of the lower face of c' is not changed by the magnetic field. Then if the only effect of the field were to decrease the conductivity of the bismuth, the temperature recorded by both thermocouples would rise, and these increases in temperature would be proportional to the distances of the junctions from the cylinder, c' . Thus, knowing the rise in temperature produced at the lower thermocouple which was not affected by the extraneous galvanomagnetic effects mentioned above, one can calculate the rise at the upper couple by simple

proportion. Thus T_1 and T_2 , and hence also k_H may be determined. This method can be applied only if one can be sure that the temperature of c' did not change during the course of the experiment. In the determinations taken at two field strengths, the temperatures were recorded first with no field, then with the field on, and finally with the field off, and in these cases it is quite certain that the temperature of c' did not drift. The observations thus recorded are plotted as squares on Fig. 4 and Fig. 2.

The calculation of these points is subject to small errors; thus in calculating the rise in temperature of the upper thermocouple, no account was taken of the fact that the portion of the specimen above the upper thermocouple was colder than the rest of the specimen, so that the magnetic field probably produced a greater change in the conductivity of this part of the specimen than it did in the conductivity of the region lying between the two junctions. Thus the actual rise in temperature at the upper junction, when the magnetic field was applied, was probably greater than the rise calculated by means of the simple proportion indicated above. This source of error would cause the calculated value of $\frac{\Delta k}{k}$ to be too great. The ordinates of the two points plotted as squares, Fig. 4, should therefore be somewhat reduced. Also the change in conductivity due to the rise in temperature when the field was applied was ignored in the calculation of these two values of $\frac{\Delta k}{k_0}$. The thermocouples in this case were so close together (5.1 mm separation) that the temperature difference recorded by the

two thermocouples was very small, so that the error of observation of the change in this difference as the field is applied is quite large, and these two points merely show that with fields of 8400 and 11,100 gauss respectively the values of $\frac{\Delta k}{k_0}$ obtained with the thermocouples inserted into the bismuth as in A are approximately the same as those which were subsequently obtained with the thermocouples inserted as in B.

To eliminate these extraneous galvanomagnetic effects, the thermocouples were insulated from the bismuth as in A' above. The thermocouples inserted in this way, when vacuum conditions were very good, were found to record temperatures considerably higher than those observed when the junctions were inserted as in method A. When the pressure was increased to about one cm of mercury, the thermocouples recorded about the E.M.F. which they did in method A with the same heat flow, and the apparent conductivity was about six percent greater than the values obtained with the thermocouples inserted as in method A and with good vacuums. (See Bridgman, l.c.)

One could not be certain, however, that the E.M.F. at the junctions was controlled entirely by the temperatures of the specimen at the points at which they were inserted into the bismuth. If the junctions are insulated thermally from the specimen, conduction along the thermocouple leads may increase the temperature of the small junction. After four unsuccessful attempts to insulate the thermocouples

electrically and still get enough thermal contact with the bismuth, this scheme was discarded. At each trial, the junctions were found to be firmly glued into the holes so that under ordinary pressures it may be assumed that there was fair contact, but each time as the pressure was decreased to about 10^{-6} mm of mercury, it was found that there was apparently very poor contact.

This idea is borne out by some of the early observations in which great care was not exercised to get the best possible contact between the cylinder c' and the disc d. In these observations, when the cup was filled with air and observations were made with always the same heating current, the average temperature of the specimen was found to increase very slowly and quite uniformly over a period of about a week of pumping. After that, these temperatures did not essentially change from day to day. This indicates that the space between the threaded part of c' and the disc d gradually became evacuated so that the resistance to a flow of heat across this junction gradually increased.

The curious result, 31, Table I, may be due to something like this. The average temperature of the specimen during this run was -36°C . After the completion of this determination of k, the pressure was increased to about 2 cm of mercury (all other experimental conditions being kept fixed) and the average temperature of the specimen dropped to -150°C . When the apparatus was taken apart after this run,

it was found that c' was screwed into the disc only about one and three-fourths turns, while it took two and a half turns to secure good contact.

These observations would also lead one to believe that the heating coil may be quite a bit warmer than the cylinder to which it is glued with shellac. If one desired to be able to make a quite certain correction for the conduction of the heating leads, it would be desirable to fasten the ^{insulated}/heating coil to c with Wood's metal so that the temperature of the coil could be taken as nearly that of the lower thermocouple when the latter is inserted into c.

When the thermocouples were fixed as in method B, the total difference in temperature recorded by the thermocouples is the drop through 11 mm of bismuth, plus the drop through 3 mm of copper, plus the drop through the thin, uniform layer of Wood's metal. The drop through the copper would be about 1/120 of that through the bismuth and the drop through the thin layer of Wood's metal should be ignorable. Comparison of the value k in the absence of the magnetic field obtained by method A, with those obtained by method B, indicates that these small temperature drops may be neglected. An error introduced by ignoring them would cause the values of k as determined by this method to be lower than those obtained by method A, whereas they are, in fact, slightly higher.

E. Errors in Obtaining k_0 from Fig. 3.

It will be observed that at -125°C one cannot be certain of the slope of the curve, Fig. 3, from which k_0 is taken in the calculation of $\frac{\Delta k}{k_0}$. If one chooses a different slope as indicated by the dotted line, Fig. 3, the 24% change in conductivity, 13, Table I, would be increased to 24.4% and the 3.8% change, 26, Table I, would be practically unaffected. The other values of $\frac{\Delta k}{k_0}$ given in this series, 11 to 20, Table I, would be affected less than is the 24% change, since the temperatures at which k_H was observed in smaller fields were nearer to temperatures (-123 and -125) at which k was determined in the absence of the field. Thus only a slight uncertainty is introduced into curve 1, Fig. 4, because of the uncertainty of the slope of the curve, Fig. 3, at -125°C .

The determinations, 7 to 9, were taken hurriedly with a heating current of 1.08 amp. in order to see what temperatures would be recorded by the thermocouples with this value of the heating current. It was desired to attain the same average temperature of the specimen with method B as registered previously with the thermocouples inserted as in method A. After the determination, 21, Table I, was made, a magnetic field of 8400 gauss was applied to make observation 22. After the first three pairs of observations of the temperatures registered by thermocouples in this experiment, the temperature recorded by the lower couple suddenly dropped to a new value at which it remained steady

for five minutes. Then the magnetic field was reduced to 4450 gauss and determination 22, Table I, was made. Comparison with the other results plotted in Fig. 3 and in Fig. 4 indicates that the first part of this series of observations was affected by some extraneous influence. Thus the value of k , 21, Table I, is apparently too high, and the value of $\frac{\Delta k}{k_0}$, 22, Table I, is also apparently too high. The value of $\frac{\Delta k}{k}$, 23, Table I, when plotted in Fig. 4 falls between curve 1 and curve 2, and may be correct. The author is not able to state definitely the cause of the sudden drop in the temperature recorded by the lower thermocouple; but as stated before, this series of observations was made hurriedly; and it may be that the first observations of this series had been taken too soon after ice had been applied to the "cold" junctions of the thermocouples.

The apparent error in the experiments discussed in the preceding paragraph indicates that the temperatures registered by the thermocouples should be maintained constant for at least 20 minutes in any given experiment. This was done in those experiments which yielded the results plotted in curves 1 and 2, Fig. 4.

Since $\frac{\Delta k}{k_0}$ is a function of the temperature of the specimen as well as of the magnetic field strength, it would be desirable to have the average temperature of the specimen exactly the same in every determination plotted on one of the curves, Fig. 4. However, if one assumes that the variation of $\frac{\Delta k}{k_0}$ with temperature may be taken as approximately linear

over a temperature range of forty degrees, the difference between the mean temperature at which the results plotted on curve 1 were observed and the mean temperature at which those results plotted on curve 2 were observed, it can be shown that a difference in temperature of five degrees will not alter the values of $\frac{\Delta k}{k_0}$ by more than ^{the} experimental error. Thus we may consider that within the limit of experimental error the curves 1 and 2, Fig. 4, show how $\frac{\Delta k}{k_0}$ varies with field strength if the temperature of the specimen is kept constant.

DISCUSSION OF THE VALUES OF $\frac{\Delta k}{k_0}$ OBTAINED BY THE AUTHOR

The accuracy with which the points fall on the curves, Fig. 4, is at first surprising since it is well known that ordinary conductivity measurements do not yield such consistency, especially if the experimental conditions are very slightly altered. It must be remembered, however, that in a series of determinations, say those plotted in curve 1, Fig. 4, heat losses may be assumed to be small and to be constant, thus not affecting the curve, and errors made in determining the dimensions of the specimen do not affect the observation of the variation of conductivity with field strength. The position of the potentiometer slide which indicated the temperatures of the two thermo-junctions was observed with a good magnifying glass, and it was surprising to see how steady the readings were in view of the fact that

liquid air has a boiling point which depends upon how "fresh" the air is. To show this consistency, the last determination made, the observation with a field of 5000 gauss, curve 2, Fig. 4, is recorded in detail below. The corresponding reading with no field need not be recorded.

Time	Potentiometer slide (cm)	
	Lower Thermocouple	Upper Thermocouple
6:49 P.M.		11.46 cm
:50	7.42 cm	
:52		11.48
:53	7.42	
:54		11.47
:56	7.42	
:57		11.47
:58	7.43	
:59		11.47
7:00	7.43	
:03		11.47
:04	7.43	
:07		11.46
:08	7.42	

All of the readings from which the data for curves 1 and 2, Fig. 1, were calculated are about as consistent as the above. It was only necessary to wait long enough for steady temperatures to become established.

From zero to the point showing 16% increase in conductivity, curve 2 is similar in form to the curve which Kay and Higgins¹⁵ obtained with a single crystal, principal cleavage plane perpendicular to the axis of the specimen. For low fields the slope of their curve increases quite rapidly with field strength, but at higher fields the slope

decreases slowly with field strength. (In this comparison we invert their curve, since they have plotted k_H against field strength while the author has plotted $\frac{k_0 - k_H}{k_0}$ against field strength.) Working at 27°C, they had to use 9000 gauss to get a change of 16% and their variation between zero and 9000 gauss is very much like that part of curve 2 which lies between zero and 4500 gauss. With the cleavage plane parallel to the heat flow, Kay and Higgins obtained much smaller results and the curve did not indicate any reversal of curvature.

Curves 1 and 2, Fig. 4, are very similar in shape to Kapitza's¹⁶ curves, α_1 and α_2 , Fig. 16, which show the variation of the electrical resistance of poly-crystalline bismuth with magnetic field strength. Kapitza, however, used very much stronger fields to get this type of variation.

In one important respect, the results of Kay and Higgins are very interesting. The changes in conductivity which they observed are very much larger than any which had previously been observed. This contrast is similar to Kapitza's¹⁷ observation that in single crystals magneto-resistance is much greater than it is in poly-crystals. Kapitza also finds that the deviation from the square law $\frac{\Delta \sigma}{\sigma} = BH^2$ which he observed at very high fields appears sooner if a single crystal is used; and that the more perfect the crystal, the smaller is the field required to show this deviation and the greater is the change in electrical resistance due to the magnetic field. Since the crystals used by Kay and Higgins

had obviously been much abused in machining (they were very short and wide cylinders), it seems desirable to repeat their work, using as perfect crystals as can be obtained.

Observations at low temperatures with perfect crystals are very likely to exhibit interesting results in this field, as they did in Kapitza's work. It is interesting to note that the last four points on curve 1 and the last three of curve 2 show almost a linear increase with field strength, but there still is a little curvature. It would be very desirable to extend the work to higher field strengths to see if the curve continues on as a straight line as the field is further increased. A magnet has been built in this department which is capable of about 30,000 gauss with the pole separation required in this work (about 1.4 inches). With so great a field the portion of the curve in question could be extended over about five times its present range. This magnet is at present being used for other work, but it may be that in the future a favorable opportunity to use it without interfering with any other work will present itself.

CONCLUSION

From the present work, we may conclude:

1. That with decreasing temperature, the effect of magnetic fields on the thermal conductivity of bismuth increases greatly.

2. That as long as the field is not too great, $\frac{\Delta k}{k_0}$ apparently follows the theoretical square law, $\frac{\Delta k}{k_0} = BH^2$ but at greater fields the decrease in the thermal conductivity of bismuth is proportional to some power, less than the first, of H.

Unfortunately, bismuth has a complicated structure and in some respects is not well behaved. One would like to work with a metal which has a simpler structure and is thus easier to handle theoretically, but bismuth was selected because it gave the most promise of effects large enough to be studied. From the behavior of the upper couple when it was inserted into c, one can conclude that in copper the effect is small even at low temperatures, but of course the total drop in the copper was quite small, so that a small change in the conductivity would not be observable with the present apparatus.

In conclusion, the author wishes to thank Professors Mendenhall, Ingersoll, and Roebuck, and all others of this department who from time to time have offered suggestions, to express his desire to follow up some of the

interesting points discussed above, and to express the hope that some theoretical physicist will tackle the problem of the effect of a magnetic field on thermal conductivity. Sommerfeld⁹ has made a good start toward the solution of this problem but has not quite solved it. His work has stimulated many others, and it may be that someone will take up this problem.

REFERENCES

1. A. Rhigi, Am. Jour. Science, (3), 34, p. 228;
Jour. d. Phys., (2), 8, p. 609, 1889.
2. A. Leduc, Compt. Rendu, 104, p. 1783, 1887.
3. A. von Ettingshausen, Wied. Ann., 33, p. 129, 1888.
4. V. J. Blyth, Phil. Mag., (6), 5, p. 529, 1903.
5. F. A. Ward, Phil. Mag., (6), 48, p. 971, 1924.
6. P. Kapitza, Proc. Roy. Soc., (A), 123, p. 342, 1929.
7. G. H. Livens, Phil. Mag. (6), 30, p. 526, 1915.
8. A. Sommerfeld, Zeit. für Phys., 47, p. 1, 1928.
9. F. Bloch, Zeit. für Phys., 53, p. 216, 1929.
10. R. Peierls, Zeit. für Phys., 53, p. 255, 1929.
11. Bridgman, Proc. Amer. Acad., 61, p. 101, 1926; and
and Gruneisen and Goens, Zeit. f. Phys., 44, p. 615,
1927; and 46, p. 151, 1928; used apparatus very much
like that employed by the author in their experimental
comparison of conductivities. Kannuluik and Laby,
Proc. Roy. Soc., 121, p. 640, 1928, sought to determine
the actual value of the conductivity of a single
crystal of copper by the method employed by the author.
References to other thermal conductivity methods
which have been adapted to vacua are given in their
article.
12. Houllevigue, Jour. d. Phys. (3), 5, p. 53, 1896.
13. W. Nernst, Wied. Ann., 31, p. 760, 1887; Amer. Jour.
Science (3), 34, p. 53, 1896.
14. A. Smith, Phys. Rev. (2), 2, p. 383, 1913.
15. Kay and Higgins, Phil. Mag. (7), 8, p. 1056, 1929.
16. P. Kapitza, Proc. Roy. Soc. (A), 119, p. 401, 1929.
17. P. Kapitza, Proc. Roy. Soc. (A), 126, p. 683, 1930.
18. For a convenient summary of the work on related phenomena
see L. L. Campbell, "Galvanomagnetic and Thermomagnetic
Effects," Longmans, Green and Company, 1923.