

Analyzing the Effectiveness of Illustrations in Information and Communications

Technologies (Networking Emphasis)

Textbooks

by

Donald H. Gaber

A Research Paper
Submitted in Partial Fulfillment of the
Requirements for the
Master of Science Degree
in

Career and Technical Education

Approved: 2 Semester Credits

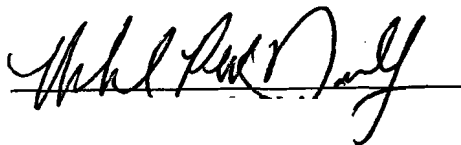
A handwritten signature in black ink, appearing to read "Michael R. Dandy", is written over a horizontal line.

The Graduate School

University of Wisconsin-Stout

July, 2007

**The Graduate School
University of Wisconsin-Stout
Menomonie, WI**

Author: Gaber, Donald H.
Title: *Analyzing the Effectiveness of Illustrations in Information and
Communications Technologies (Networking Emphasis)
Textbooks*

Graduate Degree/ Major: MS Career and Technical Education

Research Adviser: Donnelly, Michael P.W., Ph.D.

Month/Year: July 2007

Number of Pages: 96

Style Manual Used: American Psychological Association, 5th edition

ABSTRACT

Visual imagery plays an important role in learning. Research confirms the effectiveness of combining text and illustrations to promote enhanced learning from instructional media. However, many authors, publishers, and educators may not recognize what constitutes effective illustrations, or consider the tangible effect illustrations have on learning. Knowledge of elements that make illustrations effective is not formalized, so authors are often left to discover how to make effective illustrations by a process of trial-and-error combined with learning from examples.

The purpose of this study was to develop criteria for determining effective use of illustrations in information system textbooks. The researcher conducted a review of the literature from the domains of cognitive psychology and learning style research, technical writing, communication, and graphic illustration disciplines. This body of work served as the base in development of a scale for rating illustration effectiveness. The researcher then

utilized the rating scale by analyzing textbook illustrations from a university level program. A cluster sampling method was used, and consisted of the textbooks required for the networking emphasis component of the Information and Communication Technologies program at the University of Wisconsin-Stout.

The results indicated a wide range in the number, size, and effectiveness of illustrations for each textbook. However, the overall effectiveness rating indicated no significant difference between textbooks for the sample. From simple arrows and icons to complex graphs and schematic diagrams, creating effective illustrations requires consideration to human cognition characteristics and matching illustrations to the target audience.

The Graduate School
University of Wisconsin Stout

Menomonie, WI

Acknowledgments

I would like to thank Laura, my friend and wife of 27 years, for her support and encouragement during my graduate studies. I would also like to express gratitude to Dr. Howard Lee, my advisor and instructor who encourages and appreciates hard work, dedication, and serves as a role model for others in the teaching profession.

Many thanks to Dr. Michael Donnelly, my research advisor, for his expert advice and opinions, and for encouraging me to turn an average paper into a research endeavor, where the more I dug in, the more interesting it became; making for a great learning experience.

Dedicated to my Dad, whose humor we all miss :)

Richard E. Gaber 1930-2006

TABLE OF CONTENTS

	<i>Page</i>
.....	
ABSTRACT	ii
List of Tables	viii
List of Figures	ix
Chapter I: Introduction.....	1
<i>Background Information</i>	1
<i>Statement of the Problem</i>	5
<i>Purpose of the Study</i>	5
<i>Research Questions</i>	6
<i>Significance of the Study</i>	6
<i>Assumptions of the Study</i>	7
<i>Limitations of the Study</i>	8
<i>Definition of Terms</i>	8
<i>Methodology</i>	9
Chapter II: Literature Review	10
<i>Introduction</i>	10
<i>Defining Visual Imagery and Illustrations</i>	10
<i>Pictures, Images, and Photographs</i>	11
<i>Tables</i>	11
<i>Graphs, Charts, and Plots</i>	12
<i>Diagrams and Schematics</i>	14
<i>Shapes</i>	14
<i>Symbols</i>	15

<i>Flowcharts</i>	16
<i>Screenshots</i>	17
<i>The Role of Research</i>	18
<i>Effective versus Non-Effective Illustrations</i>	23
<i>Pictures, Images, and Photographs</i>	24
<i>Diagrams and Schematics</i>	26
<i>Flowcharts</i>	29
<i>Screenshots</i>	30
<i>Graphs</i>	32
<i>Tables</i>	37
<i>Common Components</i>	38
<i>Captions</i>	38
<i>Legends or Keys</i>	38
<i>Lines and Arrows</i>	39
<i>Clip Art</i>	40
<i>Summary</i>	40
Chapter III: Methodology	41
<i>Introduction</i>	41
<i>Selection and Description of the Sample</i>	41
<i>Instrumentation</i>	42
<i>Data Collection</i>	42
<i>Data Analysis</i>	43
<i>Limitations</i>	44
Chapter IV: Results.....	45

<i>Introduction</i>	45
<i>Purpose of the Study</i>	45
<i>Sample Information</i>	45
<i>Item Analysis</i>	46
<i>Discussion and Summary of Findings</i>	51
Chapter V: Discussion, Conclusions, and Recommendations	54
<i>Introduction</i>	54
<i>Summary</i>	54
<i>Conclusions</i>	55
<i>Recommendations</i>	58
References.....	60
Appendix A: Illustration rating scale instrument.....	67
Appendix B: Illustration rating examples.....	75

List of Tables

Table 1: Dunn and Dunn Model of Learning Style Preferences.....	20
Table 2: Definition of perceptual strengths	21
Table 3: Preferred visual illustrations for specific purposes.....	24
Table 4: ICT network emphasis required textbooks.....	41
Table 5: ICT network emphasis required textbooks.....	45
Table 6: Effectiveness statistics for each category	49
Table 7: Somewhat effective picture illustration results.....	76
Table 8: Effective picture illustration results.....	77
Table 9: Somewhat effective diagram illustration results.....	79
Table 10: Effective diagram illustration results.....	80
Table 11: Somewhat effective flowchart illustration results	82
Table 12: Effective flowchart illustration results.....	83
Table 13: Somewhat effective screenshot illustration results.....	85
Table 14: Effective screenshot illustration results.....	86
Table 15: Somewhat effective graph illustration results.....	87
Table 16: Effective graph illustration results.....	89
Table 17: Somewhat effective table illustration results.....	91
Table 18: Effective table illustration results	92
Table 19: Somewhat effective combination illustration results.....	94
Table 20: Effective combination illustration results.....	95

List of Figures

Figure 1: Terminology and location of key elements of a table	12
Figure 2: Terminology and location of key elements of a graph.....	13
Figure 3: Diagram of the human eye	14
Figure 4: Typical geometric shapes	15
Figure 5: Typical mathematical operators	15
Figure 6: Flowchart example from an information technology textbook.....	16
Figure 7: Screenshot illustrating the Word Count feature	17
Figure 8: Parts and steps illustrations	23
Figure 9: Electronic schematic diagram example from a textbook	28
Figure 10: Block diagram example from an information technology textbook.....	28
Figure 11: Terminology and construction options of flowcharts.....	29
Figure 12: Flowchart examples from an information technology textbook	31
Figure 13: Screenshots illustrating the Word Count feature.....	32
Figure 14: Data distortion example.....	34
Figure 15: Graph example exaggerating data	35
Figure 16: Graph example in proper context	35
Figure 17: Chartjunk examples	36
Figure 18: Grey shades examples	36
Figure 19: Graph indicating percentage of illustrations per textbook	46
Figure 20: Graph indicating average illustration size per page	47
Figure 21: Graph indicating number of individual types of illustrations.....	48
Figure 22: Graph indicating effectiveness rating for each category	49
Figure 23: Graph indicating overall effectiveness rating comparison.....	50

Figure 24: Somewhat effective picture illustration.....	75
Figure 25: Effective picture illustration.....	77
Figure 26: Somewhat effective diagram illustration.....	78
Figure 27: Effective diagram illustration.....	80
Figure 28: Somewhat effective flowchart illustration	81
Figure 29: Effective flowchart illustration.....	83
Figure 30: Somewhat effective screenshot illustration.....	84
Figure 31: Effective screenshot illustration	86
Figure 32: Somewhat effective graph illustration.....	87
Figure 33: Effective graph illustration.....	89
Figure 34: Somewhat effective table illustration.....	90
Figure 35: Effective table illustration	92
Figure 36: Somewhat effective combination illustration.....	93
Figure 37: Effective combination illustration.....	95

Chapter I: Introduction

Background Information

Ever since humans have been aware of their own learning, there have been questions regarding how they learn and retain specific knowledge. Long before the current alphabetic method of recording text was developed to record and transmit information, significant events were recorded using visual representations. For example, the Chauvet cave drawings depicting the significance of animals relative to human existence were discovered in the Ardèche valley in Southern France, and are estimated to be at least 30,000 years old (Balter, 2006). In the seventeenth century, Comenius published his "Didacta Magna," which stated that visualizing information was particularly important for effective learning (Schnotz, 2002). The human brain has a large capacity for information storage and retrieval; however, the process of storing and retrieving information, such as a student attempting to acquire knowledge using a textbook, varies from person to person. There has been a great deal of research in the cognitive psychology field to determine how the human mind encodes, stores, and retrieves knowledge.

A form of research that directly relates to how people comprehend and retain knowledge is the study of learning styles. Learning styles are defined as different strengths and preferences in the way a person takes in or processes information (Felder & Spurlin, 2005). The learning style definition used by Felder and Spurlin encompassed a variety of modalities that may include auditory, verbal, tactile, and visual; for the purpose of this study, the focus will be centered on the visual learning style in relation to visual imagery; specifically, illustrations used in textbooks.

Gardner developed the theory of Multiple Intelligences (1983), where he identified seven intelligence types relating to learning style, personality, and behavior. Of the seven, the spatial-visual intelligence category involves people's potential for recognizing and manipulating visual imagery and patterns as their dominant learning style.

The Dunn and Dunn Model of Learning Style Preferences, created by Dunn, Dunn, and Price (1990) is a complex model represented by five major categories, each consisting of different sensory and perceptual elements that affect our learning. According to Dunn and Dunn, perceptual strengths from the physiological category "may be the most important aspect of learning style" (1999, p. 15). The physiological category explains how visual stimuli as an element can improve the visual learner's ability to tap learning strengths (Dunn, 2000). Chapter two includes further discussion of the model.

Fleming developed the VARK categories of sensory modalities for learning, and the VARK learning style questionnaire. Fleming and Mills defined a visual learner as preferring graphical and symbolic ways of representing information (1992).

Over the past decade, interest in the relationship of text to visual imagery has become important to researchers and practitioners alike who acknowledge the need to understand the relationship between image and language, as technologies become part of the writer's toolbox (Benson, 1997). According to Benson, communication technologies have generated an explosion of possible ways in which text and visual imagery can be combined for many purposes.

An example of a communication technologies device is the personal computer, which has become increasingly common in educational institutions during the past 25 years. The personal computer offers a means of integrating not only text and visual

imagery, but audio and video capabilities that give teachers the potential to accommodate the various modalities of their students' learning style.

Research indicated that computers and software could be used to reach learning style preferences with dramatic results. However, many educators have yet to use computers to their fullest advantage (Geisert & Dunn, 1991).

Given all the available technology that can stimulate these learning styles, the Association of American Publishers stated that 90% of college professors surveyed by Zogby in 2006 still require or recommend a textbook for the courses they teach (cited in Scarazzo, 2006).

Research conducted throughout the 1970's and 1980's found that textbook illustrations enhanced learner's performance (Carney & Levin, 2002). During that time, Alan Paivio developed the Dual Coding Theory, defining two distinct learning systems: the verbal coding system adapted for text-based information emphasizing words, sentences, conversations, and the story system, where the imaginal coding system accentuates non-verbal information in the form of pictures, sensations, and sounds (cited in Paivio, Clark, & Lambert, 1988). Paivio predicted that when information is encoded into both systems in parallel, it is more easily recalled than information only coded in verbal or imaginal systems individually. Carney and Levin suggested that research conducted during the 1990's still support the assertion that illustrations in textbooks enhanced learning (2002).

The use of pictorial information in learning and instruction is centuries old, but today, instructional materials include more pictures, diagrams, and graphs than a few decades ago (Schnotz, 2002). The latter part of the 20th century has seen a considerable

increase in the use of images in textbooks (Kress, 1997). Evidence confirms that textbooks utilizing a high amount of imagery are more conducive to recalling information, and that imagery is important to memory and cognition (Sadoski, Goetz, & Rodriguez, 2000).

Given the significance of research indicating the value of combining text and visual imagery to enhance learning, the increased numbers of illustrations in textbooks is not surprising. A study of textbook selection criteria published by Nova University found that visual imagery was an important factor regarding textbook selection by professors for their courses (Bartlett, 1991). The quantity of illustrations may be criteria for authors, publishers, and faculty who select textbooks; however, the quality, relevance to textual content, and use of illustrations to facilitate deeper learning may be disregarded. Many textbook images are considered little more than decoration, and have no relationship to the text content (Carney & Levin, 2002). Harp and Mayer referred to interesting, but irrelevant images as “seductive illustrations” (1997, p. 92). They defined interesting to signify that readers would rate the material as entertaining and interesting. They defined irrelevant as not being related to a step in a cause-and-effect explanation, even though it may be related to the topic.

The preceding information suggests that research-based educational institutions such as the University of Wisconsin-Stout (UW-Stout) have access to, and may be aware of these methods and findings. UW-Stout is a member of the University of Wisconsin system, and is located in Menomonie, Wisconsin. The student enrollment consists of over 8,000 students, and close to 400 total faculty and staff (UW-Stout, 2007a). UW-Stout is a quality institution that embraces the latest research and technology, and integrates them into their curriculum and mission. In 2001, UW-Stout was the first university to be

awarded the prestigious Malcolm Baldrige National Quality Award, considered America's highest honor for achieving excellence in performance in higher education (UW-Stout, 2007b).

UW-Stout demonstrated its leadership in revolutionary instruction methods by fully implementing the digital laptop program in 2005. The initiative enables teachers and all on-campus students to utilize a computer laptop as a teaching and learning tool. UW-Stout utilizes modern technologies and methods that allow teachers to reach students with various learning styles. However, the use of standard textbooks is common practice for many courses.

The Information and Communication Technologies (ICT) program at UW-Stout has developed curriculum combining digital and textbook media to encourage deeper learning by a diverse range of students. This study intends to offer the ICT program insight into the effectiveness of textbooks required for the networking emphasis component of the program.

Statement of the Problem

Research confirms the effectiveness of combining text and illustrations in instructional media to promote enhanced learning. However, many authors, publishers, and educators who select textbooks for courses they teach, may not recognize what constitutes relevant, quality illustrations, or consider the tangible effect the illustrations have on learning.

Purpose of the Study

The primary purpose of this study is to develop criteria for determining effective use of illustrations in educational media. The secondary purpose is to analyze the

illustrations in the textbooks required for the networking component of the Information and Communications Technologies program during the 2006-2007 academic school year at UW-Stout. The results of this study could provide valuable information regarding the effectiveness of illustrations in textbooks, and assist in determining criterion for selection of textbooks for future courses.

Research Questions

This study sought answers to the following questions:

1. What is the definition of visual imagery, and its correlation to illustrations, in the context of an educational textbook?
2. What is the role of cognitive psychology in the development of effective illustrations?
3. What constitutes an effective versus non-effective illustration?
4. Which criteria will be useful in development of a rating scale for effective textbook illustrations?
5. How do the illustrations in the textbooks used for the networking component of the ICT program at UW-Stout measure on the developed rating scale?
6. Is there a significant difference in the rating between textbooks from varying authors or publishers?

Significance of the Study

This study is significant for the following reasons:

1. The analysis and rating of illustrations in this study will focus on information and communication technology textbooks. However, the rating scale may be utilized across various academic disciplines and may be applied to non-textbook media, such as digital or web-based content.

2. The researcher could find no studies measuring a correlation between the effectiveness of textbook illustrations to academic achievement in the information and communication technologies discipline. This study may serve as a base for follow-up research.

3. A number of faculty members at UW-Stout write or co-author textbooks in various disciplines. This study may serve as a guide when considering the inclusion of effective illustrations necessary to meet the needs of the intended audience.

Assumptions of the Study

The following assumptions are noted for this study:

1. It is assumed the textbooks required for the given courses used in this study, whether currently in use or discontinued, will be available to the researcher.
2. It is assumed that different types of illustrations are best suited for conveying different types of understanding.
3. It is assumed that the illustrations and text should compliment and address each other to meet the common goal of enhancing learning.
4. It is assumed that people using implied standards design textbook illustrations.
5. It is assumed that the literature review will result in the criterion necessary for the development of a researcher-designed rating instrument.

6. It is assumed that the motives for producing textbooks may vary, and the illustrations may reflect those motives.

Limitations of the Study

The following limitations are noted for this study:

1. The analysis and rating of illustrations in this study is limited to textbooks required for the networking component of the Information and Communications Technologies program offered by UW-Stout. Generalizations should not be made to other disciplines, programs, or institutions.

2. The researcher developed the rating scale used in determining the effectiveness of textbook illustrations in this study. The validity of the instrument is limited to the knowledge and information gathered and presented by the researcher.

Definition of Terms

During the course of the study, the following terms were recognized as potentially being unfamiliar to the general population or open to misinterpretation.

Cognitive psychology. The branch of psychology studying the mental processes involved in perception, learning, memory, and reasoning.

Modalities. In the context of learning style, sensory modalities are the five senses through which we take in experiences.

Non-serif. Fonts that do not use the little hooks (called serifs) on the ends of the font. Times New Roman typeface use serifs, where Verdana does not.

Quantitative. Involving the measurement of quantity or amount, normally expressed in numerical values.

VARK. The acronym VARK stands for Visual, Aural, Read/write, and Kinesthetic sensory modalities that are used for learning information (Fleming & Mills, 1992).

Methodology

Textbooks used for instruction for the networking component of the Information and Communications Technologies program at UW-Stout will be analyzed, and the illustrations will be rated using a scale to determine their potential effectiveness. The data gathered will be recorded and graphed.

Chapter II: Literature Review

Introduction

This chapter will begin by defining visual imagery and illustrations as they relate to educational media, followed by discussion of research and its role in the development of illustration usage. In addition, findings of effective versus non-effective illustrations will be reviewed, followed by the chapter summary.

Defining Visual Imagery and Illustrations

During the past 30 years, the advent of the information age, use of computers as an educational tool, and research in cognitive psychology has brought a resurgence of interest in visual imagery in educational media. Has computer technology and video phenomena created a dependency on visual stimulation, or has technology and research simply enabled us the means to rekindle our ancestral brain synapses, and learn as we did for thousands of years before written text? Either way, incorporating visual imagery into instructional media appears to be increasingly important, thus creating the need to define visual imagery in an educational context for the purpose of this study.

Barbe and Malone defined visual imagery as pictures, diagrams, graphs, and schematics, from the perspective of imagery use in media to reach visual learning styles (1981). Additional definitions of visual imagery as they applied to student learning preferences for textbook applications included symbols, tables (Felder & Spurlin, 2005), charts, shapes (Knowles, 1998), process charts or flow diagrams (Brasseur, 2003), and computer generated images known as screen captures (Pettersson, 1993). Many of these visual imagery expressions share the same meaning and may be interchangeable. The American Heritage® Science Dictionary (2002a, n.p.), defined chart and plot as being

synonymous with graph; schematic synonymous with diagram (American Heritage® Dictionary, 2000a, n.p.); and picture synonymous with image or photograph (2000c, n.p.). The preceding terminology will be defined in the following paragraphs. However, in order to simplify and clarify the study, the term illustration may be used when referring to any visual imagery expressions as described above. The American Heritage® Dictionary defined illustration as “material used to clarify or explain” (2000b, n.p.).

Pictures, Images, and Photographs

Pictures are defined as “a visual representations or images painted, drawn, photographed, or otherwise rendered on a flat surface” (The American Heritage® Dictionary of the English Language, Fourth Edition, 2000c, n.p.). In the context of use in a textbook, Wordnet® defined a picture as “an illustration used to decorate or explain a text” (2007, n.p.).

Tables

Tables are defined as “an arrangement of words, numbers, signs, or combinations of them, as in parallel columns, to exhibit a set of facts or relations in a definite, compact, and comprehensive form; a synopsis or scheme” (The American Heritage® Dictionary of the English Language, Fourth Edition, 2000e, n.p.). Graphic information expert Robert Harris defined tables as “charts with information arranged in rows and columns in some meaningful way” (1996, p. 387), and included a detailed illustration in his reference guide (Figure 1). Common uses of tables include analysis of data, reference for easy retrieval of data, scheduling, forms, and calendars.

Table heading: Title (Sales Predictions for 1996 Planning Meeting) and Subtitle (By Product Line)

Two or more levels of headings are sometimes referred to as decked.

Sometimes referred to as the stub heading

Row headings, row labels, stubs, sub items, line categories, categories, or captions

Subheadings

A line generally indicating a computation, such as a total, has occurred, if no or few horizontal lines are used in the body of the table, a single line is frequently used. If lines are used in the body, a double line may be used

Shaded area is referred to as field or body

Vertical axis

Horizontal axis

Sometimes referred to as the stub

Columns

Leader

The bottoms of columns are sometimes referred to as feet.

Spanner headings bridge two or more columns

Spanner rule

Subspanner headings

Subspanner rule

Column headings, column captions, column titles, column labels, or boxheads

The area where a column and row intersect (indicated here by the bold line) is called a cell.

Rows

Vertical grid lines or rules

Horizontal grid lines or rules

Base line

Product		Sales			
		1995 Estimate		1999 Forecast	
		Dollars (\$00)	% of total	Dollars (\$00)	% of total
Drills	Large	14.4	8.6	25.6	12.2
	Medium	28.2	16.9	45.6	21.7
	Small	40.8	24.5	76.4	36.4
Nail Drivers	Large	6.7	5.4	13.2	6.3
	Small	11.4	6.8	15.1	7.2
Torque Wrench	Large	6.2	3.7	8.1	2.8
	Small	8.9	5.3	11.3	5.4
Saws	Pneumatic	4.3	2.6	7.1	3.4
	Electric	5.9	3.5	6.6	2.4
Total		166.7	100.0	210.0	100.0

If multiple terms are used to describe the same thing, each of the terms are shown above. • When tables are used in specific applications, parts of the tables are sometimes given additional names related specifically to the application. For example, when used in a database, a column might be called a field and a row referred to as a record.

Figure 1. Terminology and location of key elements of a table

From *Information Graphics: a Comprehensive Illustrated Reference* (p. 387), by R. Harris, 1996, Atlanta, GA: Management Graphics. Copyright 1996 by Management Graphics. Reprinted with permission.

Graphs, Charts, and Plots

Graphs are defined as “a diagram showing the relationship of quantities, especially such a diagram in which lines, bars, or proportional areas represent how one quantity depends on or changes with another” (The American Heritage® Science Dictionary, 2002a, n.p.). Harris defined a graph or plot as “a chart that graphically displays quantitative relationships between two or more groups of information” (1996, p. 176). There are dozens of categories, subcategories, and combinations of different types of graphs. For the purpose of this study, Harris’ graph example will be sufficient (Figure 2).

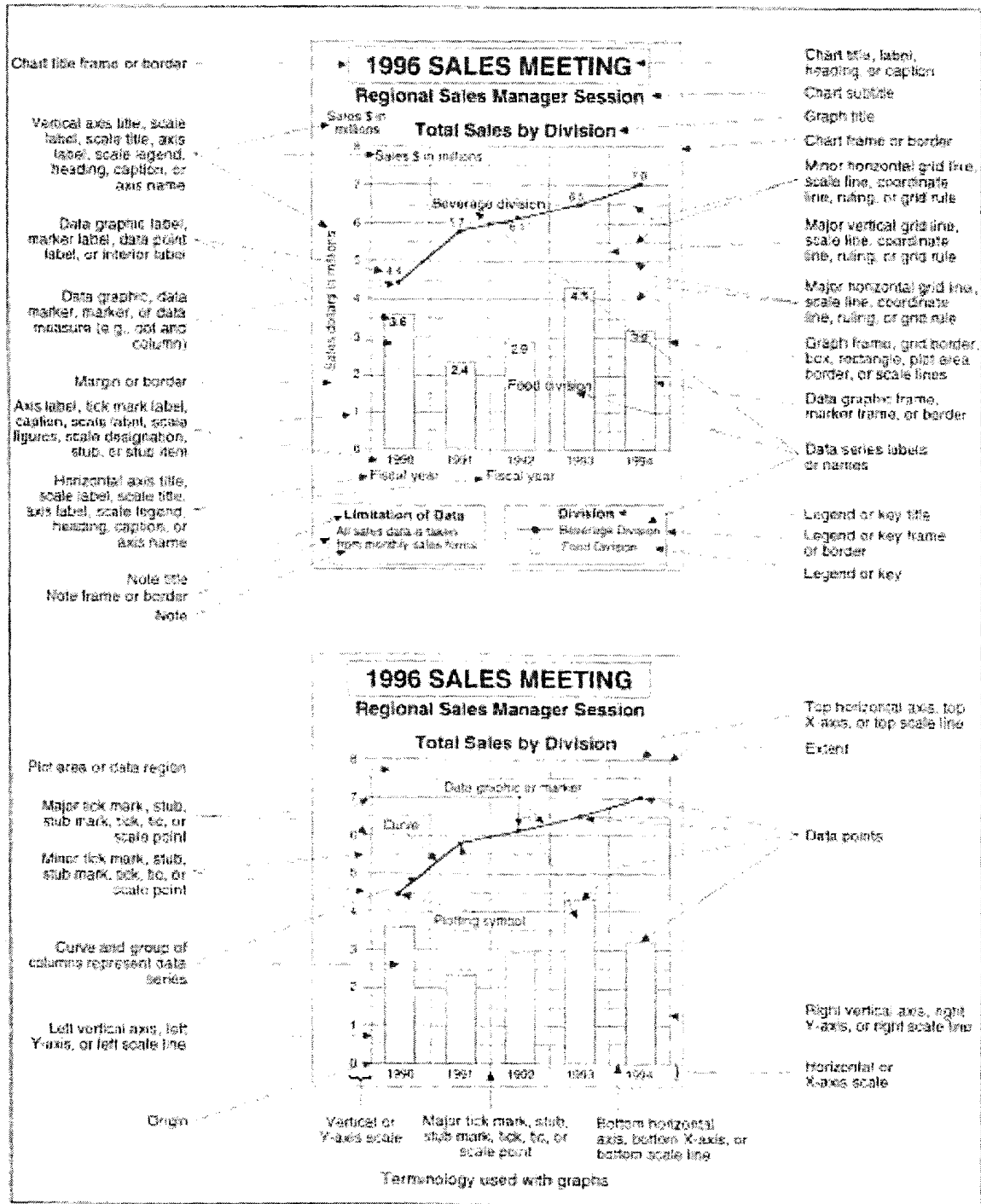

Figure 2. Terminology and location of key elements of a graph

From *Information Graphics: a Comprehensive Illustrated Reference* (p. 177), by R. Harris, 1996, Atlanta, GA: Management Graphics. Copyright 1996 by Management Graphics. Reprinted with permission.

Diagrams and Schematics

A diagram or schematic is defined as “a plan, sketch, drawing, or outline designed to demonstrate or explain how something works or to clarify the relationship between the parts of a whole” (The American Heritage® Dictionary of the English Language, Fourth Edition, 2000a, n.p.). An example of a diagram that displays the parts of a whole is the cross section of a human eye as defined by the National Eye Institute (Figure 3).

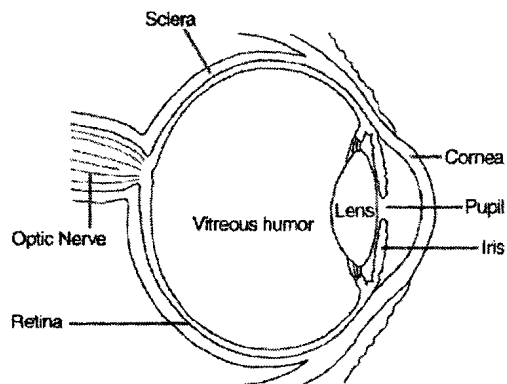

Figure 3. Diagram of the human eye

From the National Eye Institute website. Retrieved April 5, 2007 from:

www.nei.nih.gov/health/eyediagram/index.asp. Image designated as public domain.

Shapes

Shapes are defined as “the characteristic surface configuration of a thing; an outline or contour” (The American Heritage® Dictionary of the English Language, Fourth Edition, 2000d, n.p.). Individual components that make up various textbook illustrations may be chosen for their particular shape to add a desired effect. In the context of a textbook illustration, a shape may define a geometric figure with greater success than a verbal description alone (Figure 4).

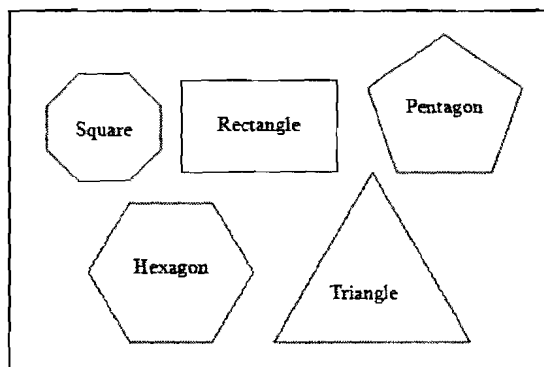

Figure 4. Typical geometric shapes created using Microsoft® Word

Microsoft product screen shot reprinted with permission from Microsoft® Corporation.

Symbols

Symbols are defined as “a conventional, printed, or written figure used to represent an operation, element, quantity, and relation, unit of measurement, phenomenon, or descriptor” (The American Heritage® Science Dictionary, 2002b, n.p.). The use of symbols in a textbook may encompass a broad range of uses. A typical use of symbols in a textbook may include an illustration of functions (Figure 5).

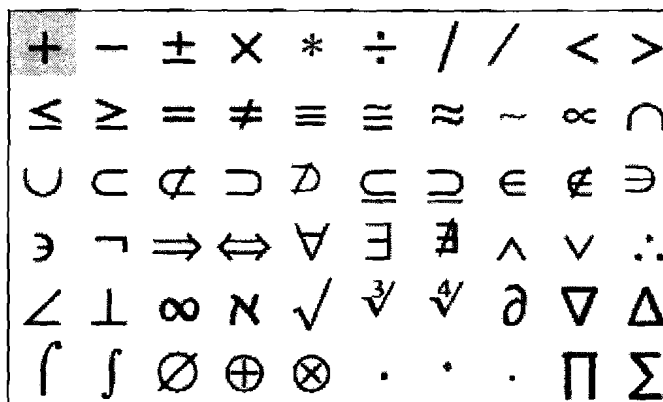

Figure 5. Typical mathematical operators created using Adobe® Photoshop®

Adobe product screen shot reprinted with permission from Adobe® Systems Incorporated.

Flow Charts

Process charts, flow diagrams, or flow charts, are typically synonymous, and are used to show, rather than tell what happens in a process to help readers reach a clearer understanding faster (Brasseur, 2003). Flow charts visually display interconnected information such as functions, steps, or processes in succession by utilizing text enclosed by symbols, and connected by lines or arrows (Harris, 1996). An example of flowchart usage in an information technology textbook is the control program, depicting a top-down approach to design in Figure 6.

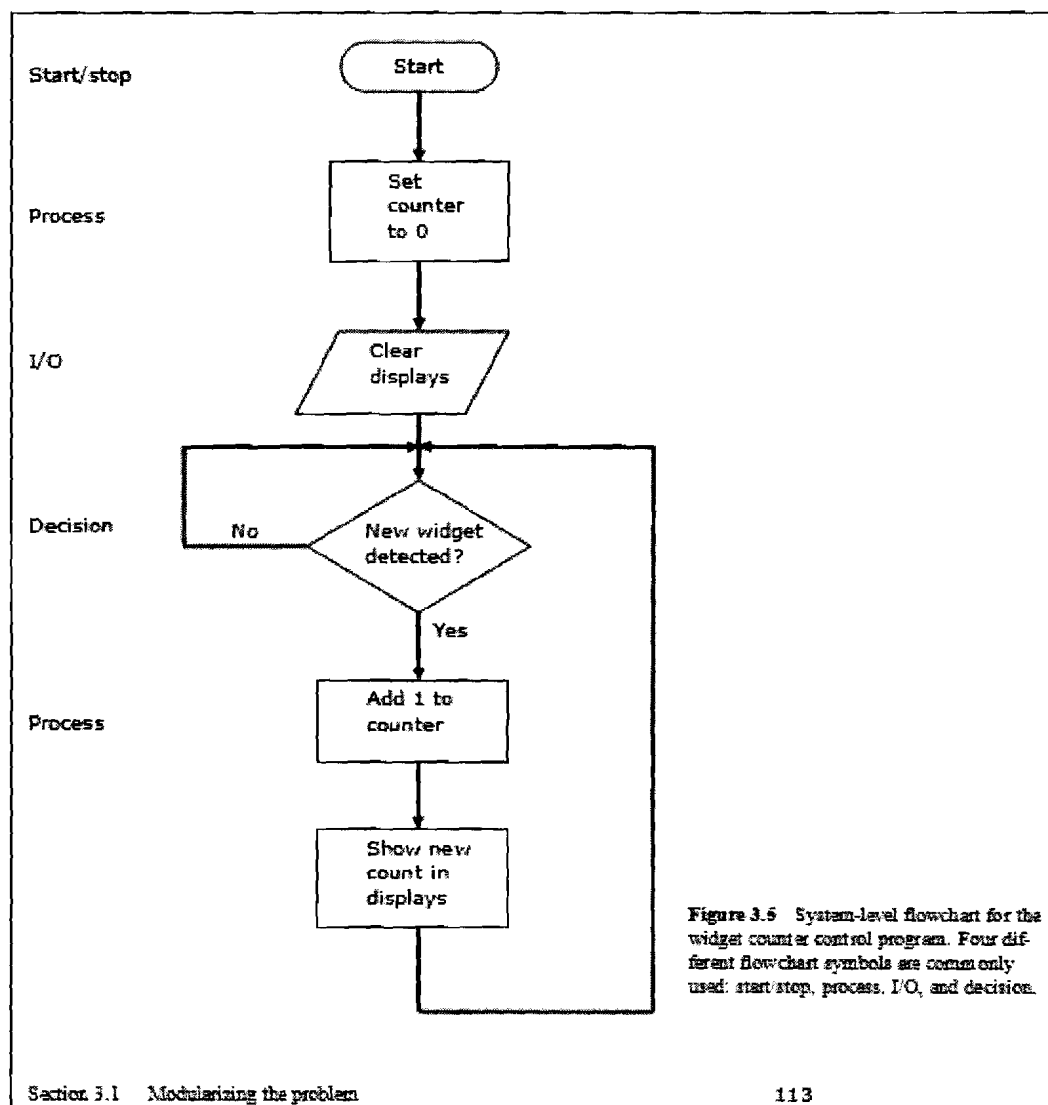

Figure 6. Flowchart example from an information technology textbook

From *The 8086/8088 Family: Design, Programming, and Interfacing* (p. 113), by J. E. Uffenbeck, 1987, Englewood Cliffs, NJ: Prentice Hall. Reproduced with permission from the author.

Screenshots

A screen shot is defined as “a reproduction of the current display on a computer screen, saved as a graphics file; also written [screenshot]; also called [screen capture]” (Webster's New Millennium™ Dictionary of English, Preview Edition, (v 0.9.6, 2006, n.p.). The use of screenshots to depict computer software functions is common in information technology textbooks. The researcher generated the example of a screenshot (Figure 7).

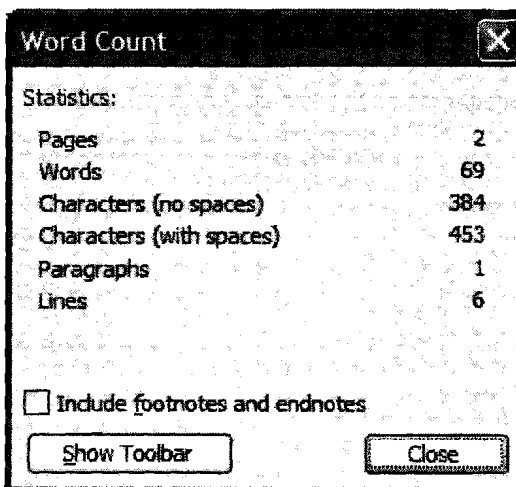

Figure 7. Screenshot illustrating the Word Count feature in Microsoft® Word
Microsoft product screen shot reprinted with permission from Microsoft® Corporation.

The preceding illustrations used to aid in the definition of visual imagery are examples of how text and illustrations combine to help define otherwise lengthy or

difficult to describe concepts. If one were to attempt to describe or communicate the preceding concepts or images to another person using only written text, the task might be quite challenging for both persons. When including illustrations in textbooks, one must consider the correct combination of data, lines, shapes, colors, descriptors, topic relevance, images or any combination thereof, to produce effective illustrations. The most important reason for including illustrations in educational materials should be to promote learning (Willows & Houghton, 1987).

The Role of Research

The study of visual imagery and its function has been ongoing in the cognitive psychology field since pre-1900 (Paivio, 1991). It was not until the early 1970's when Paivio's dual-coding theory became the first systematic objective approach to the study of text and imagery that attracted scientific attention to motivate imagery research by others. In simple terms, "the essence of dual-coding theory is that there are two distinct systems for the representation and processing of information" (Eysenck & Keane, 2000, p. 262). The verbal system deals with language in the form of text, and the separate, nonverbal system executes image-based processing.

Paivio stated that there have been many misinterpretations since he first published his theory in 1971 (1991). The verbal and nonverbal units, which he first referred to as verbal and imaginal coding, actually come in different modalities – "visual (printed words vs. visual objects), auditory (spoken words vs. environmental sounds), haptic (tactual and motor feedback from writing vs. manipulation of objects)" (p. 258), and other sensory responses (taste, smell, and emotion). Paivio stated these systems take in stimuli as verbal and nonverbal, but are frequently interpreted as simply verbal and visual, with the sensory

motor side overlooked. The theory is actually a multiple coding theory, with a special emphasis on the importance of verbal and nonverbal symbolic contrast.

Another assumption is that the two systems function independently of one another (Paivio, 1991). In order to help clarify this assumption, Paivio replaced his original verbal and imaginal coding system terminology by adopting the terms logogen (word generator), and imagen (image generator) from Morton (1969). Paivio described a logogen as a modality-specific component that acts as a built-in informational source or response generator (1991). For example, the word dog may have logogens that are represented by different modalities; hearing the word "dog," and seeing the letters "d-o-g," may invoke a mental visual image of a dog. The equivalent to logogens in the nonverbal system is imagens, described as sensorimotor modalities that act as an image generator. For example, seeing an image of a dog, whether real or pictorial, or touching a dog, would invoke a representation of a dog. The key concept to dual-coding is that both systems are functionally interconnected, and work together to process information.

The three main processes that describe Paivio's dual-coding theory are representational processing, where logogens are activated by linguistic stimuli (text) and imagens by nonverbal stimuli (visual images); referential processing, refers to the two systems working together; and associative processing, where the images or words are associated with an object (1991).

Paivio's initial experiments included subjects memorizing either a list of words or a set of pictures in an educational context (1971). Paivio found that pictures were remembered more readily than words, thus beginning a flurry of research by others in

related areas such as learning style and development of effective educational media by combining text and images.

Paivio's research findings aided many disciplines, including learning style research. Of the numerous studies, research on the Dunn and Dunn model of learning styles is more extensive than most preceding learning studies (Dunn & Dunn, 1993). They initiated their research on how individuals responded to alternative teaching methods in 1967 with the New York Department of Education. Among the theories of learning styles, Dunn and Dunn's Model of Learning Style Preferences (cited in Dunn, Dunn, & Price, 1990) defined a biological and developmental set of personal characteristics that affect learning. The model is represented by five major categories, called "stimuli," consisting of different sensory and perceptual elements that describe how students learn most efficiently based on their personal strengths (Table 1).

Table 1

Dunn and Dunn Model of Learning Style Preferences

Stimuli	Perceptual Elements
Environmental	Light, sound, temperature, room design
Emotional	Structured planning, persistence, motivation, and responsibility
Sociological	Pairs, peers, adults, self, group, and varied
Physiological	Perceptual strengths, mobility, intake, and time of day
Processing style	Global/analytic, impulsive/reflective, and right- or left-brain dominance

According to Dunn and Dunn, perceptual strengths from the physiological category "may be the most important aspect of learning style" (1999, p. 15). Perceptual strengths are categorized into four sensory modalities, which are defined in Table 2.

Table 2

Definition of perceptual strengths

Modality	Definition/ability
Auditory sense	Differentiate among sounds to reproduce symbols, letters, or words by hearing them.
Visual sense	Associate shapes and words to conjure up the image of a form by seeing it in their mind's eye.
Tactual sense	Associate word formations and meanings by involving a sense of touch.
Kinesthetic	Utilize real life experiences in order to recognize words and their meanings.

The Dunn and Dunn research identified that individual learners may utilize a combination of the four modalities to maximize learning potential. When students were introduced to new material through their perceptual preferences however, they learned more than when they were introduced through their least preferred modality (1993). Their research indicated the need to supplement textbooks with other modes of instruction for greater success. However, the inclusion of descriptive text combined with images, shapes, and explanatory illustrations have proven effective for increasing learner interest.

To determine illustration effectiveness, its purpose must be identified, and the function must be defined. Illustrations incorporate visual imagery to aid readers in the decoration, representation, organization, or interpretation of information (Levin, 1981). The decoration function utilizes text-irrelevant illustrations in an attempt to make the textbook more attractive, increase publisher sales, or an effort to increase student interest

in the material. For example, a drawing of a pine tree next to the description of a hiking trail (Carney & Levin, 2002), or the use of progressively larger clip-art images of a guy in a track suit representing revenue growth on a corporate graph (Tufte, 2006).

The representation function utilizes illustrations that help reinforce the content of the text (Levin, 1981). Where a decorative illustration shows little or no relationship to the textual information, a representative illustration directly relates to a good portion of the critical textual information. Figure 8 shows an example where the text describing the systematic progression of a car's braking process is reinforced by the image of the braking system.

The organizational function utilizes illustrations to present an organizational framework, giving text greater coherence (Levin, 1981). For example, the use of an illustrated map or an illustration depicting the steps involved in performing cardiopulmonary resuscitation (Carney & Levin, 2002).

Finally, the interpretational function uses illustrations to clarify hard-to-understand passages and abstract concepts within passages (Levin, 1981). The key function of an interpretational illustration is to help the reader understand information.

Research performed by Mayer and Gallini focused on illustration effectiveness and the interpretational function, which they called explanative illustrations (1990). In the study, three similar experiments were conducted where students read passages describing how scientific devices work. One of the experiments had students read a passage depicting the hydraulic braking system of an automobile. The first group read a passage that contained no illustrations. The second group read the passage that contained static illustrations depicting a diagram of the device with labels for each part (parts). The third

group read the passage that contained static illustrations explaining each major step (steps). The fourth group read the passage that contained dynamic illustrations, where the “on” or “off” states of the device, along with labels for parts and each action were depicted (parts-and-steps). The results of the study “indicated that the parts-and-steps illustrations consistently improved performance on recall of conceptual information and creative problem solving” (Mayer & Gallini, 1990, p. 715). Figure 8 represents an example of the parts and steps illustrations used in the study. Mayer (1989) stated that for illustrations to be effective in promoting understanding of scientific text, the explanatory illustrations must help the learner visualize a mental model of the system.

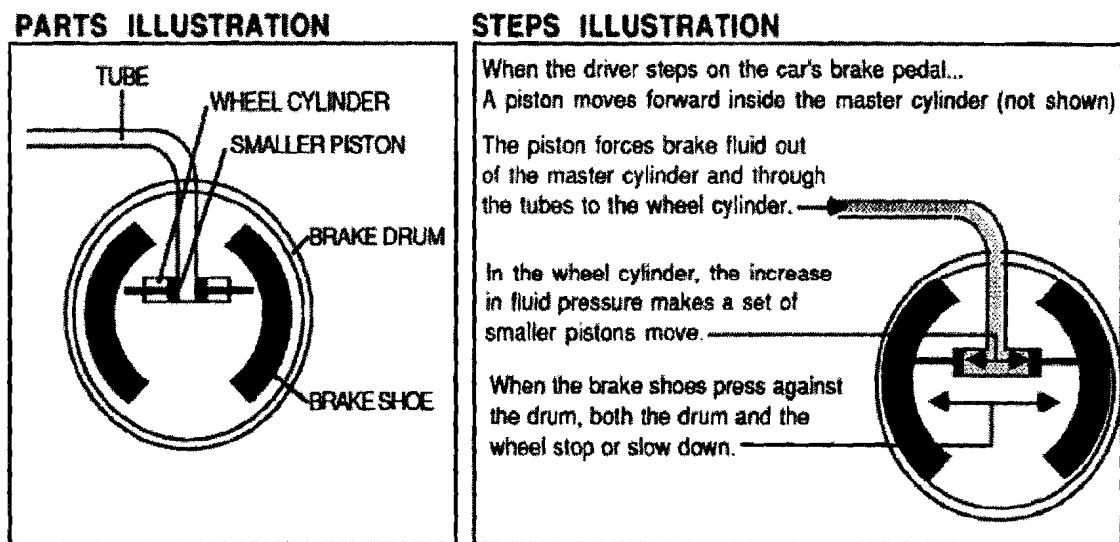

Figure 8. Parts and steps illustrations

From “When is an illustration worth ten thousand words?” by R. E. Mayer and J. K. Gallini, 1990, *Journal of Educational Psychology*, 82(4), p. 716. Copyright 1990 by American Psychological Association. Reprinted with permission.

Effective versus Non-Effective Illustrations

Cognitive psychology and learning style research demonstrates the advantages of including illustrations in educational media. However, to be effective, the illustrator must

consider their particular purpose and the abilities and preferences of the intended readers (Lannon, 2000). General audiences are likely to favor illustrations such as basic tables, diagrams, or graphs that direct their center of attention and interpret key points of the information. Expert audiences are likely to favor flowcharts, complex graphs, numerical tables, or schematics that enable them to interpret the information for themselves.

Table 3 depicts effective illustration choices for specific applications (Lannon, 2000, p. 264).

Table 3

Preferred visual illustrations for specific purposes

Purpose	Preferred Illustration
Organize numerical data	Table
Show comparative data	Table, bar graph, line graph
Show a trend	Line graph
Interpret or emphasize data	Bar graph, line graph, pie chart, map
Introduce an unfamiliar object	Photo, representational diagram
Show how parts are assembled	Photo, exploded diagram
Give instructions	Prose table, photo, diagrams, flowchart
Explain a process	Flowchart, block diagram
Describe a mechanism	Photo, representational diagram, or cutaway diagram

Pictures, Images, and Photographs

Considered the oldest form of visual imagery, people have been creating pictorial illustrations for at least 35,000 years (Carney & Levin, 2002). Painted images might have served as adjunct aids helping to define humankind development. Similarly, pictorial illustrations are an important, more recent development in educational media, serving to

aid learners by reinforcing the text. Images or pictures in educational media should serve to compliment text, and aid in reading to learn.

Simply looking at a picture in a textbook invokes a highly sophisticated mental processing system, and understanding how this system functions can help in creating effective illustrations (Kosslyn, Thompson, & Ganis, 2006). Kosslyn, Thompson, and Ganis identified four main functions or mechanisms that operate during visual processing and defined them as image generation, image inspection, image maintenance, and image transformation.

According to Kosslyn, Thompson, and Ganis, image generation begins upon initial observation of an image when the brain searches long-term associative memory for stored information of shapes to create an object map of the image in a visual buffer, or short-term memory (2006). If the shape is simple, a memory sub-system accessing long-term associative memory may quickly produce a representation and generate the image in the memory buffer. If the image is complex, like a picture of a bicycle or an object that has multiple components, the image process is repeated as necessary for each individual component to generate the whole image in the memory buffer.

The next step is the image inspection, where the now temporarily stored image in the buffer is inspected and encoded (e.g., if one were asked to describe the button on a computer mouse, they might visualize the whole mouse, and examine the button from there); (Kosslyn, Thompson, & Ganis, 2006). The image patterns are scanned and recognized by comparing the image to stored visual memories, where certain characteristics may “pop out,” or be inspected without scanning. Object-based images fade quickly, so image maintenance by means of re-activating the visual memory must occur

before the image can be transformed. Image transformation is complete when the reader can visualize the object as if they were able to physically manipulate it.

To be effective, the mental image during the transformation stage must be large and clear (Kosslyn, Thompson, & Ganis, 2006). To accomplish this, the pictorial illustration must have clear, sharp lines, and be large enough to reveal locations of distinct basic parts and their characteristics.

If a photograph is used as an illustration, technical communication expert John Lannon suggested the following guidelines (2000). Show the image at approximately the same angle that readers would use while actually identifying components or performing a procedure. Crop the photograph to remove unnecessary details. Label all the parts that readers need to identify. If the image is unfamiliar, include a familiar object or ruler to give a sense of scale. The key element for effectiveness of pictorial images is that they represent the function, rather than serve as decoration.

Inexpensive digital cameras and publishing software create a cost-effective, efficient means of incorporating pictures into media. The use of clear, precise photographs may not be the most effective means of reinforcing text, however (Lynch, 1990). Sociologist Michael Lynch indicated that scientific illustrations, when compared to photographs of the same object, simplify reality, better define the object, and provide an easily understandable view.

Diagrams and Schematics

Similar to pictures, diagrams may invoke Kosslyn, Thompson, and Ganis' theory of the complex visual processing system (2006). However, diagrams used simple shapes and lines that enable readers to increase retention of the image in short-term memory

(Brasseur, 2003). Clear and uncluttered diagrams or schematics are examples of scientific illustrations that may eliminate unnecessary details, and allowed the reader to focus on essential material (Lannon, 2000). Hand drafted or computer generated diagrams allowed the illustrator greater flexibility to manipulate and customize the image to meet the needs of the intended audience.

Common types of diagrams used in textbooks and manuals include exploded, cutaway, and block diagrams (Lannon, 2000). The exploded diagram depicts an object “pulled apart” to enable easy identification of its individual parts. To be effective, the illustrator may label the parts on the illustration if the number of parts is small enough to eliminate clutter or confusion (e.g., the diagram of the human eye in Figure 3). If the object contains many parts, using a numbering scheme and a parts list may be more effective. Cutaway diagrams enable illustrators to show the item with its exterior layers removed in order to reveal the internal components. Like the photograph guidelines, the angle of the object illustrated by the diagram should represent the best view for the reader. If the view is not immediately recognizable, the angle should be labeled as “top view,” “side view,” and so on.

“Block or schematic diagrams present the conceptual elements of a principle, process, or system to depict function instead of appearance” (Lannon, 2000, p. 262). Block diagrams may use lines or arrows to connect symbols, boxes, or shapes to aid readers in developing mental models of abstract concepts (Willows & Houghton, 1987).

An example of a schematic diagram that uses lines to connect components represented by symbols is the electronic schematic of an amplifier in Figure 9. Figure 10 illustrates a block diagram from an information technology textbook that utilized separate

blocks containing both text and images connected together by arrows to help build a mental model or clarify the concept of a “smart” VCR machine. Notice the inclusion of explanatory text within the arrows.

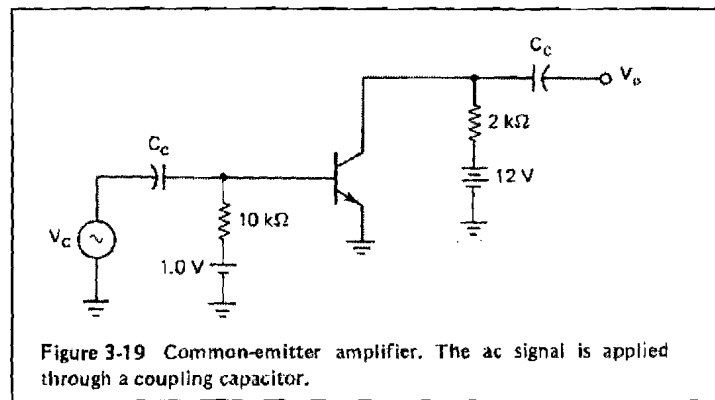

Figure 9. Electronic schematic diagram example from a textbook

From *Introduction to Electronics: Devices and Circuits* (p. 80), by J. E. Uffenbeck, 1982, Englewood Cliffs, NJ: Prentice Hall. Reprinted with permission from the author.

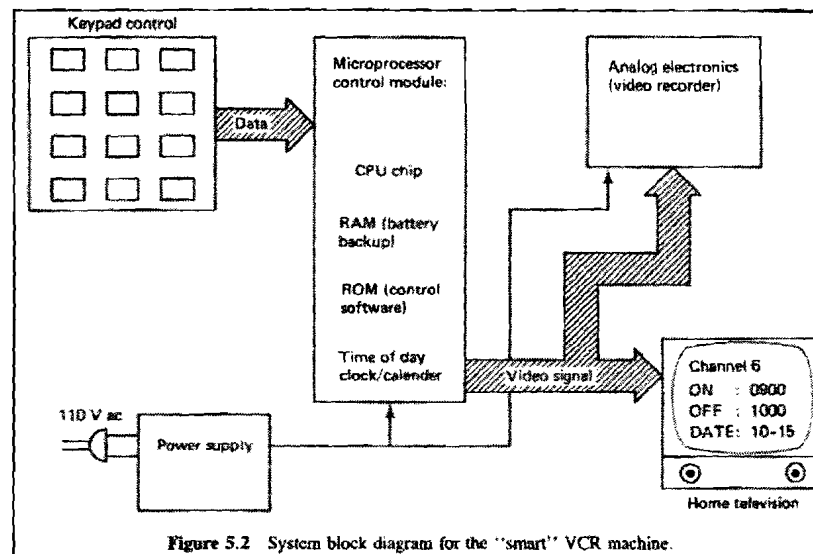

Figure 10. Block diagram example from an information technology textbook

From *The 8086/8088 Family: Design, Programming, and Interfacing* (p. 194), by J. E. Uffenbeck, 1987, Englewood Cliffs, NJ: Prentice Hall. Reprinted with permission from the author.

A member of the diagram family often used to explain logical procedures is the flow diagram, or flowchart.

Flowcharts

The flowchart is an example of an illustration that uses conventional diagram elements that have been around for centuries, such as simple shapes to represent objects, lines to represent linkage, and explanatory text (Brasseur, 2003). Flowcharts display interrelated information in a sequential manner, and can be general, for overview purposes, or detailed, perhaps representing the operation of a complex computer program (Harris, 1996). It was not until the arrival of computers that flowchart development began employing specific shapes to represent particular functions.

There are dozens of shapes, also called symbols, boxes, enclosures, or blocks that represent the various functions of flowcharts (Harris, 1996). Figure 11 depicts the most common symbols and their meanings.

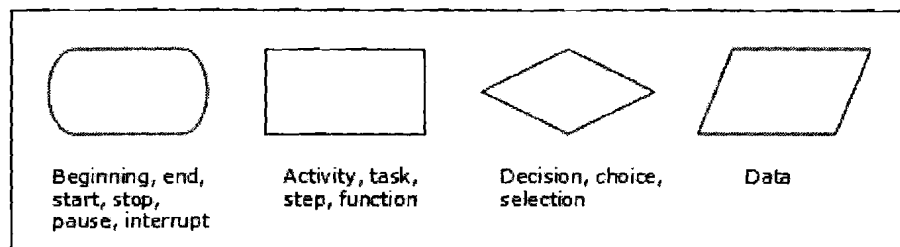

Figure 11. Terminology and construction options of flowcharts

From *Information Graphics: a Comprehensive Illustrated Reference* (p. 154), by R. Harris, 1996, Atlanta, GA: Management Graphics. Copyright 1996 by Management Graphics. Reproduced with permission.

The flowchart on the left in Figure 12 illustrates how adding appropriate text and connecting the symbols together using arrows to designate the method of flow come together to create an effective explanation of a concept. Let us look at various theories behind why the flowchart is successful in enhancing learning.

The way that we perceive visual information is also the way we think (Kosslyn, Thompson, & Ganis, 2006). When we see diagrams, we use these innate perceptual abilities to recognize and differentiate between particular shapes to build a mental model. Visually representing ideas such as categorizations in a flowchart can come close to how our mind naturally processes information.

A diagram that uses simple shapes such as squares, circles, and triangles is compatible with our natural way of thinking because they are instantly perceivable and help us both conceptualize ideas and serve as a memory device (Arnheim, 1982). For a flowchart or any type of diagram to be effective, it must succeed in communicating a particular message to the reader (Brasseur, 2003). The combination of text and images has proven effective in better understanding of the message, but a typical problem in publishing is that the text and graphics are too often separated.

Flowcharts offer the integration of text, graphics, and arrows to help readers follow a logical flow of blocks of information, and the enclosure of text and visuals decrease the likelihood that readers will “skip over” any parts of the diagram (Schriver, 1997).

Screenshots

The flowchart illustrated in Figure 12 is an example of a screenshot. With the author’s permission, the researcher was able to recreate the original image of his flowchart from the textbook using computer software, and then printing the screen. The original scan

of the page rendered an offset, unclear image, page shadows, and the text from preceding pages bled through, creating a low quality image. By re-drawing the image, and creating a screen shot, the new image is more effective.

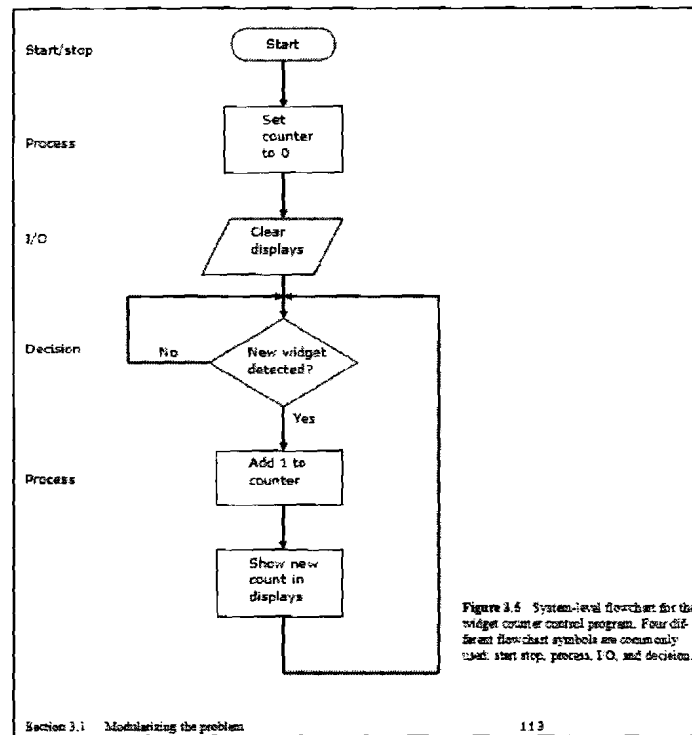

Figure 12. Flowchart example from an information technology textbook

From *The 8086/8088 Family: Design, Programming, and Interfacing* (p. 113), by J. E. Uffenbeck, 1987, Englewood Cliffs, NJ: Prentice Hall. Reproduced and reprinted with permission from the author.

Screenshots are common illustrations for information technology textbooks, as they enable illustrators the capability to easily capture the image of their computer screen anytime during its use, save the screenshot as an image file, import the image into the text themselves, or send it to their publisher or technical illustrator. All of the images in this study are scanned, downloaded, or drawn by the researcher, and then saved and printed as screenshots.

Guidelines for effective use of screenshots include allowing enough white space around and within the illustration for easy viewing (Haydon, 1995). Match the screenshot to your audience, for example, do not make it too elementary for specialists or too complex for non-specialists (Lannon, 2000). Display the sub-window or relevant portion of the screenshot that pertains to the textual content, rather than the whole screen. Figure 13 illustrates an example of the word count window (left) as compared to the whole screen (right).

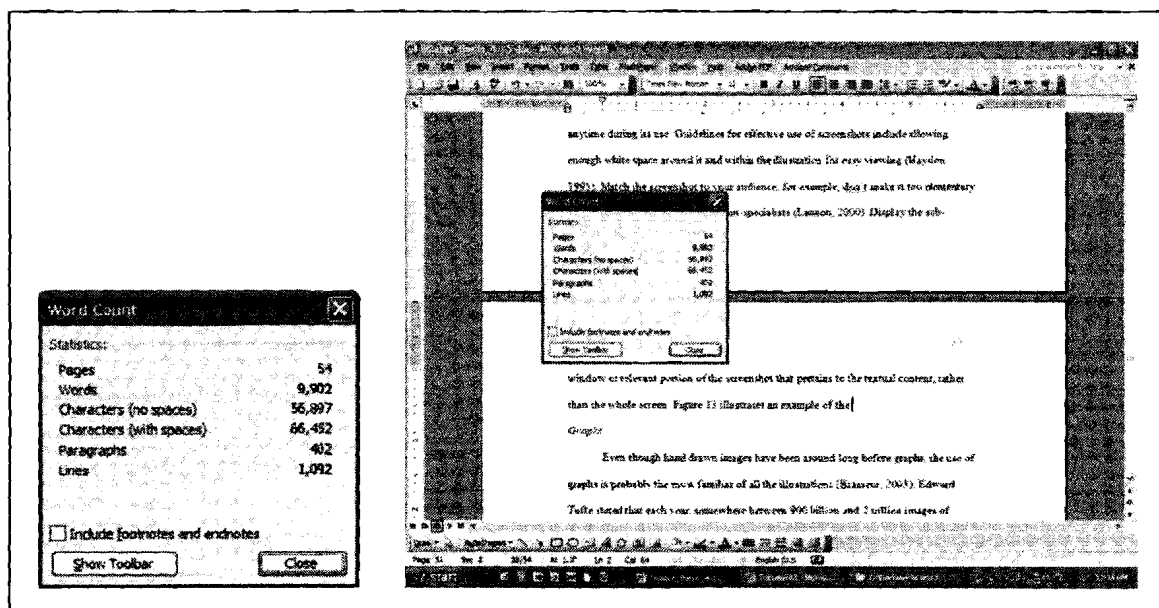

Figure 13. Screenshots illustrating the Word Count feature in Microsoft® Word
Microsoft product screen shot reprinted with permission from Microsoft®
Corporation.

Graphs

Even though hand drawn images have been around long before graphs, the use of graphs is probably the most familiar of all the illustrations (Brasseur, 2003). Edward Tufte stated that each year, somewhere between 900 billion and 2 trillion images of statistical graphics are printed (2001).

Perceptual research plays a key role in creating effective graphs (Brasseur, 2003). We must recognize certain principles of human sight and understanding of how we think about the world. For example, looking out on to the horizon, we take in a whole impression of what we see. We then sharpen our focus to understand what our eyes perceive. In other words, we do not passively take in information, but actively seek order and relationships. This principle is easily applied to graphs intended to communicate an overall idea to the reader.

Researchers Carpenter and Shaw described the three main processes readers underwent while interpreting a graph (1998). First, readers identified the important visual features, such as the slant of the curve or line. Next, the readers identified the relationship between the quantitative facts (e.g., the increase or decrease in the relationship between x and y). Finally, the readers correlated the relationship of x and y to the variables given, such as year versus population.

The graph culture has relied heavily on the large body of perceptual research in designing effective illustrations (Brasseur, 2003). For example, Jacques Bertin has identified six features of perceptual abilities referred to as retinal variables. They are spatial position, size, orientation and grey scale, color, texture, and shape (1983). Other research cites crispness, resolution, transparency, arrangement, and color – hue, value, and saturation (Card, Mackinlay, & Sheiderman, 1999). Complexity, orientation, shading, color, and typography also affect readers' perceptions (Brasseur, 1993). The preceding features are a few examples of numerous variables to consider when designing effective graphs. Since color was the only common variable in the examples, one might surmise it is the most important feature. However, another study found that the curve or line of a graph

is the point of most interest to the eye, and is in fact, a more important visual cue than color (Casali & Gaylin, 1988).

Edward Tufte has combined years of research and experience in his books on effective use of graphing statistical information. For effective graphing, Tufte developed guidelines stating what graphical displays should accomplish (2001).

Among Tufte's guidelines, avoiding distortion was important in creating effective graphs (2001). Figure 14 depicts an example of data distortion where the uniformity of numbers is not equal to the surface of the graphic itself. The numbers in the graph indicate an increase in fuel economy standards beginning with 18 miles per gallon in 1978 and progressing in steps to 27.5 by 1985, an increase of 53%. The line correlating to the 1978 figure is 0.6 inches (Line A), whereas the line correlating to the 1985 figure is 5.3 inches (Line B), indicating an increase of 783%.

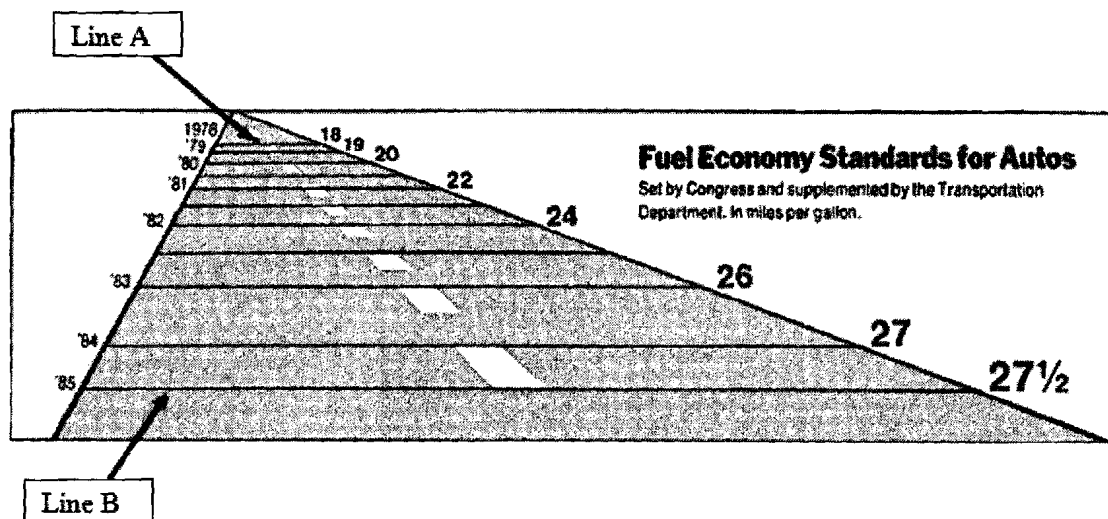

Figure 14. Data distortion example

From "A collision course on energy policy," by D.Q. Mills, August 9, 1978, *New York Times*, p. D-2. Copyright 1978 by the New York Times. Reprinted with permission.

Another of Tufte's guidelines is to encourage the eye to compare different sets of data. In other words, the reader must ask, "Compared to what?" (2001, p. 74). For example, Figure 15 illustrates what appears to be a significant increase in student GPA following a software upgrade in 2001. By adding a few more data points, the reader may see the bigger picture, and the context of the data is clearer (Figure 16).

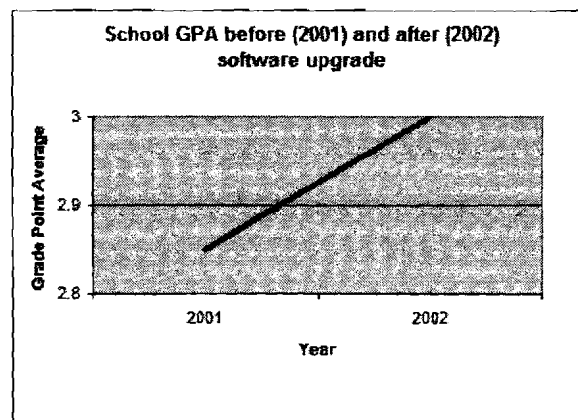

Figure 15. Graph example exaggerating data created in Microsoft® Excel
Microsoft product screen shot reprinted with permission from Microsoft®
Corporation

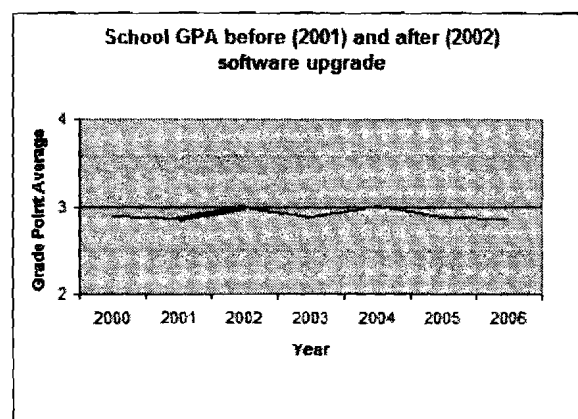

Figure 16. Graph example in proper context created in Microsoft® Excel
Microsoft product screen shot reprinted with permission from Microsoft®
Corporation

Perhaps the most important guideline is to encourage the reader to think about the substance of the graph, rather than methodology, design, technology, or “something else,” described as chartjunk by Tufte (2001, 2006). Robert Harris defined chartjunk, sometimes called clutter, as things included in graphs and charts that are not vital to the understanding, and may detract from their main intention (1996). Computer software has enabled and encouraged users to design graphs that use chartjunk. For example, Figure 17 illustrates the use of hatching to create a moiré effect, which produces the appearance of vibration or movement (Tufte, 2001). Though the reader may be drawn to the effect, it acts as a distraction. Tufte recommends replacing the cross-hatching with shades of gray (Figure 18).

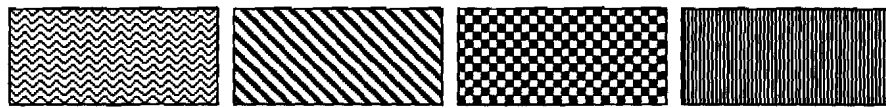

Figure 17. Chartjunk examples created in Microsoft® Excel

Microsoft product screen shots reprinted with permission from Microsoft® Corporation

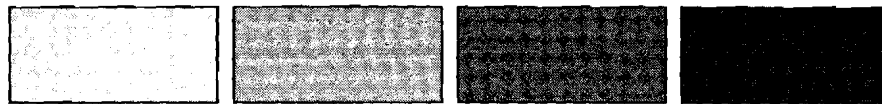

Figure 18. Grey shades examples created in Microsoft® Excel

Microsoft product screen shots reprinted with permission from Microsoft® Corporation

Graphs such as the examples in Figures 14 and 15 could have been intentionally distorted, or the graph’s designer simply failed to follow good design procedures (Tufte,

2001). Tufte suggested a table might have been more appropriate, as tables outperform graphs in reporting small data sets of 20 numbers or less.

Tables

A table, when properly prepared, can serve to explain data better than text alone and is more accurate than a graphic presentation (Haydon, 1995). Tables, like graphs, can present large numbers of precise data in a small space, but can provide many facts that cannot be expressed graphically. The configuration of rows and columns make comparisons between figures easier, but fail to display overall trends.

Guidelines for effective tables begin with the use of a table number and title centered above the table, and should be referred to by table number rather than “see table below” or “the following table” (Haydon, 1995). The use of Harris’ table example in Figure 1 may be used as a reference for the following guidelines. The table typeface should be non-serif and 1 to 1.5 points smaller than the surrounding text. For example, use Arial or Verdana typeface to clarify the smaller text. The title should be a brief and concise description of what the table represents. If the title must be longer, the use of an asterisk and a footnote should be considered. The boxhead contains the column headings in bold text. The left hand vertical column, or stub, lists the items about which information is given in the body of the table. The body contains the data below the boxhead and to the right of the stub, and should be arranged so the items in the stub appear adjacent. Footnotes that explain individual items should be referred by asterisk (*) or pound (#) so they are not mistaken for numerical data. Finally, when a table must be divided so it can continue on another page, the boxhead should be repeated, and the table number should include the “continued” label. For example, Table 1 (Continued).

Common Components

The preceding illustrations use various processes and techniques designed to enhance learning. However, many illustrations employ common components such as captions, legends, lines and arrows, and clip art.

Captions

Illustrations in a properly written textbook, whether following APA, MLA, or other writing style formats will normally use text to describe, reference, title, or label illustrations. This descriptive text is referred to as a caption in the Publication Manual of the American Psychological Association (American Psychological Association, 2001). When referring to an illustration, readers will look to the surrounding text to help understand, interpret, or explain the illustration (Brasseur, 2003). The caption placed next to, or within the illustration can help specify the nature of the illustration, give authority to the illustration (copyright), or turn a drawing into a diagram by pointing out a specific part. Captions should be brief and simple, yet complete enough to avoid ambiguity (Haydon, 1995; Lannon, 2000). Many illustrators or technical writers are too brief and omit important information necessary for complete understanding. The caption should be placed close to the illustration, preferably within boxed frames that include both graphic and text, and the type size should be smaller so the captions do not compete with the text type (Brasseur, 2003).

Legends or Keys

Diagrams and schematics, graphs, images, and tables may share a key or legend as a common element. The key is critical in understanding the illustration because it includes information necessary for decoding the graphics (Harris, 1996). For a key to be effective,

it must identify what the data graphics represent, such as symbols or icons; indicate certain characteristics of the item represented, and enable readers to estimate quantitative values.

Harris' graph example in Figure 2 illustrates a good example of a legend or key.

Lines and Arrows

Arrows and lines are elements of illustrations that do more than simply point out components. Lines can be drawn to represent diagrams, drawings, graphs, or any number of illustrations. "A line may be varied with respect to its starting point, length, direction, curvature, shape, thickness, evenness, points of change, printing, color, value, grain, brightness, orientation, terminus, and context" (Pettersson, 1993, p. 243). Horizontal lines give the impression of depth; vertical lines stop eye movement, while diagonal lines give the impression of movement. Curved lines and smooth shapes tend to stand out more than straight lines or shapes made out of straight lines.

Pettersson pointed out several reasons why lines may be considered effective in illustrations (1993). Line is an inexpensive, quick way to visualize ideas using the minimum amount of time and material. Line emphasizes basic structure and composition of a drawing, are the most readily recognizable form of illustration, and effective stimuli for learning.

Another effective common element of illustrations is the arrow. An arrow is simply a form of line utilizing a triangular shape at the end to indicate direction. The importance of arrows in illustration goes much deeper, however. Bill Winn suggested, "Any illustration can be thought of in terms of its elements and the relationships between them" (Winn, as cited in Willows & Houghton, 1987, p. 161). The arrow helps define these relationships by displaying an order of connection or sequence, and is considered a large

part of the core of visual image success. Arrow usage in flowcharts indicates the direction of flow, which normally reads like text, from left to right, top to bottom (Harris, 1996). However, the arrow may indicate a reversal of the normal order when a process is to be repeated, or signify feedback or two-way communication by using a double-headed arrow. To be effective, arrow and line density should not stand out above the graphics they represent or connect, but act as a flow mechanism.

Clip Art

Clip art is a generic term for ready-to-use images that are often included with various software packages (Lannon, 2000). Using software packages, clip art is easily imported into documents where they may be enlarged, enhanced, or customized. Some illustrators find clip art effective as icons or symbols, where others suggest it has a generic, crude, or unprofessional look.

Summary

Visual imagery in the form of illustrations in educational media plays an important role in enhancing learning. From simple arrows and icons to complex graphs and schematic diagrams, creating effective illustrations requires consideration to human cognition characteristics, learning style, and matching illustrations to the target audience. Learners who utilize educational media expect and deserve more than raw information. By combining text and illustrations, the illustrator can help readers clarify, interpret, and analyze information more effectively.

Chapter III: Methodology

Introduction

This chapter will begin by describing the selection and description of the sample to be analyzed for the study, followed by discussion of the procedure and criteria for development of the instrument used to collect data from the sample. In addition, a review of the data collection and data analysis methods will be discussed, followed by the limitations of the methodology used for the study.

Selection and Description of the Sample

A cluster sampling method was used for the study. The population consisted of the textbooks required for the non-general education Bachelor of Science Information and Communication Technologies (B.S. ICT) program at the University of Wisconsin-Stout (UW-Stout). The sample consisted of the textbooks required for the networking emphasis area of the ICT program. The textbooks used for the sample are listed in Table 4.

Table 4

ICT networking emphasis required textbooks

Title and Author(s)
Principles of Information Systems, a Managerial Approach (Stair & Reynolds, 2003)
CCNA Self-Study: Introduction to Cisco Networking Technologies (McQuerry, 2004)
Convergence of Technologies: Integrating Networks for Multimedia Solutions (Linwood, Sawyer, & Watts, 2004)
Information Technology Control and Audit (Gallegos, Senft, Manson, & Gonzales, 2004)

The sample was selected based on the availability of the textbooks to the researcher and the ICT department's cooperation and agreement to participate in this study. The

networking emphasis area (sample) consisted of 19 of the 80 required credits (23.8%) of the professional and technical studies component (population), thus surpassing the 20% suggested minimum sample size given a small population.

Instrumentation

The researcher developed the instrument used for collecting and rating the effectiveness of illustrations in educational media for this study. The rating scale instrument is located in appendix A. Development of the rating scale was based in part on findings from cognitive psychology and learning style research as it relates to enhanced learning by combining visual imagery with textual content. In-depth study of experts' publications from technical writing, technical communication, graphic illustration, and graphic information areas were gathered and combined with the cognitive and learning style research element to help design the criteria for the instrument. Due to the researcher developing the instrument, no measures of validity or reliability have been documented.

The instrument utilized the ordinal scale of measurement consisting of a Likert rating scale to measure the effectiveness of the illustrations. Criteria for rating the illustrations consisted of general guidelines for all illustrations, and a more specific set of guidelines for individual illustration types.

Data collection

The data collection method involved acquiring the list of required textbooks for the networking emphasis area of the B.S. ICT program, followed by obtaining the textbooks in order to analyze them using the instrument. The textbooks were examined page by page, with each illustration evaluated using the rating scale.

Data analysis

The data was analyzed primarily to identify statistically significant differences between the effectiveness ratings of the textbooks and individual illustration types. The researcher chose parametric t-tests to measure differences between the means at a probability level of .05 (95% confident that the data did not happen by chance). The data were compiled, and statistics representing the following information was graphed:

1. Overall number of illustrations in each textbook versus the number of pages, expressed as a percentage by dividing the number of illustrations by the number of pages per book.
2. Average illustration size, expressed as percentage of page size.
3. Number of individual types of illustrations per textbook using the following categories:
 - a. Pictures, images, and photographs
 - b. Diagrams and schematics
 - c. Flowcharts
 - d. Screenshots
 - e. Graphs
 - f. Tables
 - g. Combination
4. Effectiveness rating for each category of illustrations per textbook.
5. Overall effectiveness rating of individual textbooks by averaging all categories, and comparison of individual textbooks.

Limitations

The following methodology limitations were noted for this study:

1. This research study was limited by time and sample size. The analysis and rating of illustrations in this study were limited to textbooks required for the networking emphasis area of the B.S. ICT program offered by UW-Stout. Generalizations should not be made to other disciplines, programs, or institutions.

2. The researcher developed the rating scale used in determining the effectiveness of textbook illustrations in this study. The validity of the instrument was limited to the knowledge and information gathered and presented by the researcher.

3. This study did not use human participants; the subjects of study were the textbooks themselves.

Chapter IV: Results

Introduction

This chapter will begin by describing the purpose of the study, followed by a description of the sample. In addition, the item analysis will be reviewed, followed by the conclusion of the chapter with a discussion and summary of findings.

Purpose of the Study

The primary purpose of this study was to develop criteria for determining effective use of illustrations in educational media. The secondary purpose was to analyze the illustrations in the textbooks required for the networking emphasis area of the Bachelor of Science Information and Communications Technologies program (B.S. ICT) during the 2006-2007 academic school year at the University of Wisconsin-Stout, Menomonie.

Sample Information

The sample for this study consisted of the textbooks required for the networking emphasis area of the B.S. ICT program at UW-Stout. The program consists of six courses, with four of the courses requiring textbooks (Table 6). Of the four required textbooks, all were available and analyzed. This constitutes 100% of the sample.

Table 5

ICT networking emphasis required textbooks

Title and Author(s)

Principles of Information Systems, a Managerial Approach (Stair & Reynolds, 2003)

CCNA Self-Study: Introduction to Cisco Networking Technologies (McQuerry, 2004)

Convergence of Technologies: Integrating Networks for Multimedia Solutions (Linwood, Sawyer, & Watts, 2004)

Information Technology Control and Audit (Gallegos, Senft, Manson, & Gonzales, 2004)

Item Analysis

Item number one of the data collected from the rating scale was the number of illustrations in each textbook versus the number of pages, expressed as a percentage by dividing the number of illustrations by the number of pages per book. The resulting data is displayed in the graph in Figure 19.

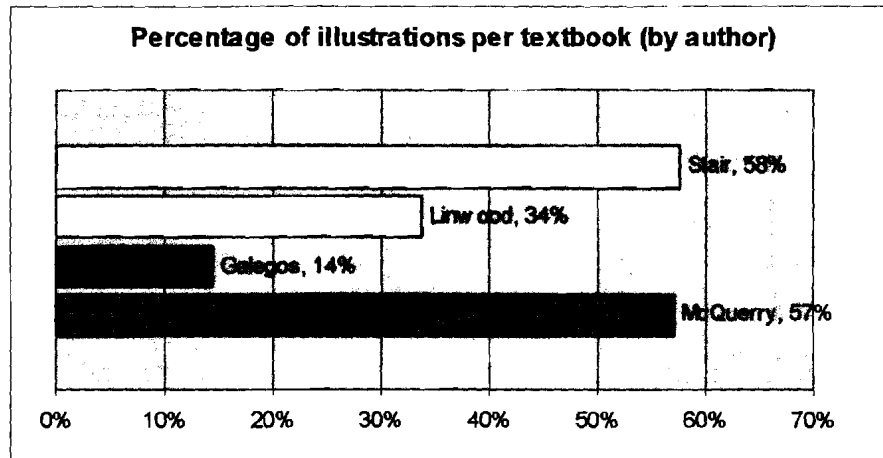

Figure 19. Percentage of illustrations per textbook.

The results indicated a range of 14% to 58% in the percentage of illustrations between the textbook with the lowest percentage of illustrations and the textbook with the highest percentage of illustrations. The combined mean of percentage of illustrations for all textbooks was 40.75%, with a standard deviation of 21.

Item number two of the data collected from the rating scale is the average illustration size, expressed as percentage of page size. The resulting data is displayed in the graph in Figure 20.

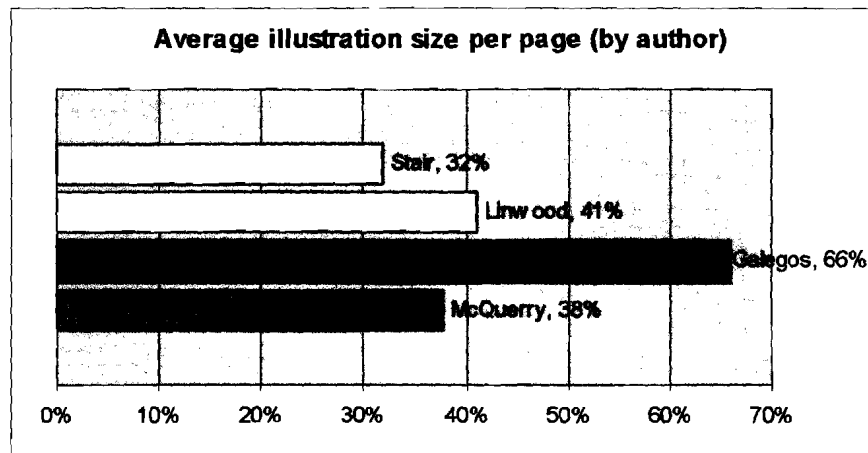

Figure 20. Average illustration size per page.

The results indicated a range of averages from 32% to 66% in average illustration size between the textbook with the smallest average illustration size and the textbook with the largest average illustration size. The combined mean of average illustration size for all textbooks was 44.25%, with a standard deviation of 14.97.

Item number three of the data collected from the rating scale is the number of individual types of illustrations per textbook using the following categories:

- a. Pictures, images, and photographs
- b. Diagrams and schematics
- c. Flowcharts
- d. Screenshots
- e. Graphs
- f. Tables
- g. Combination

The resulting data is displayed in the graph in Figure 21.

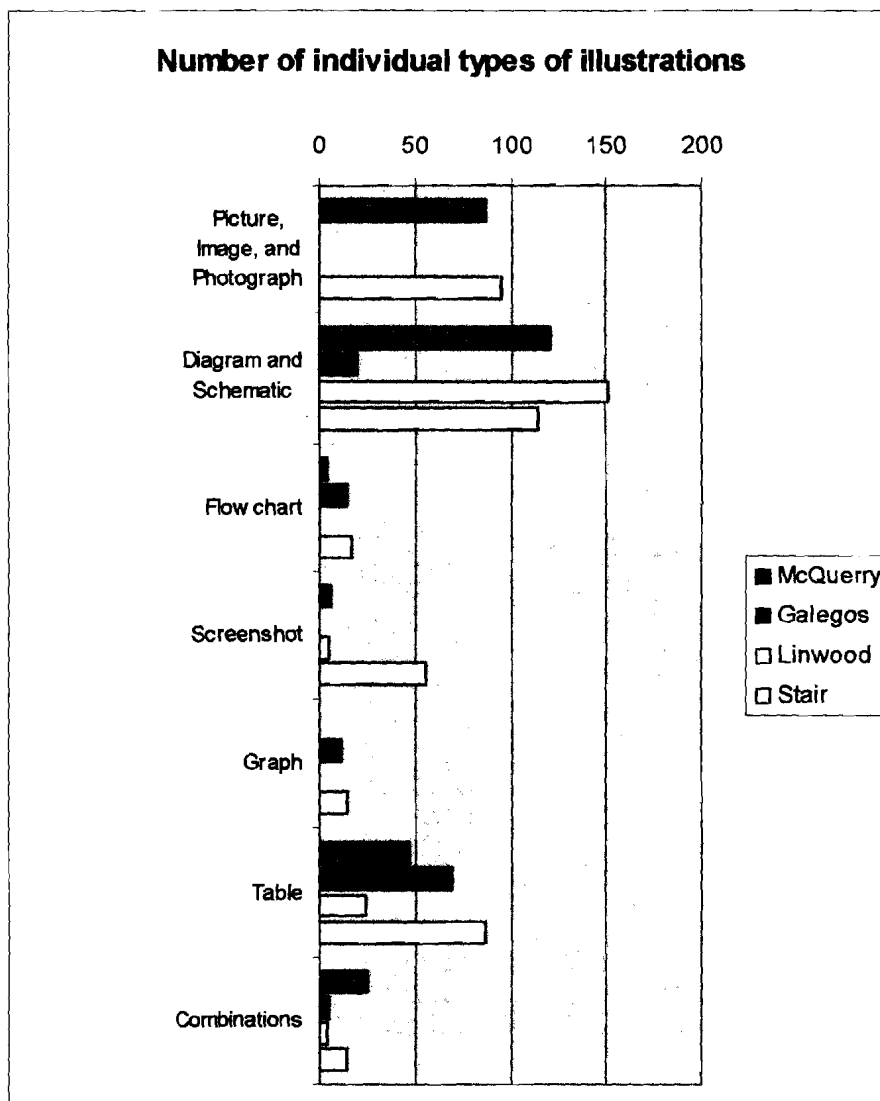

Figure 21. Number of individual types of illustrations.

The number of individual types of illustrations by themselves is more informational than significant, however, when combined with item four, which rates the effectiveness, may contribute to the overall effectiveness rating of the illustrations.

Item number four of the data collected from the rating scale is the effectiveness rating for each category of illustrations per textbook. The resulting data is displayed in the graph in Figure 22.

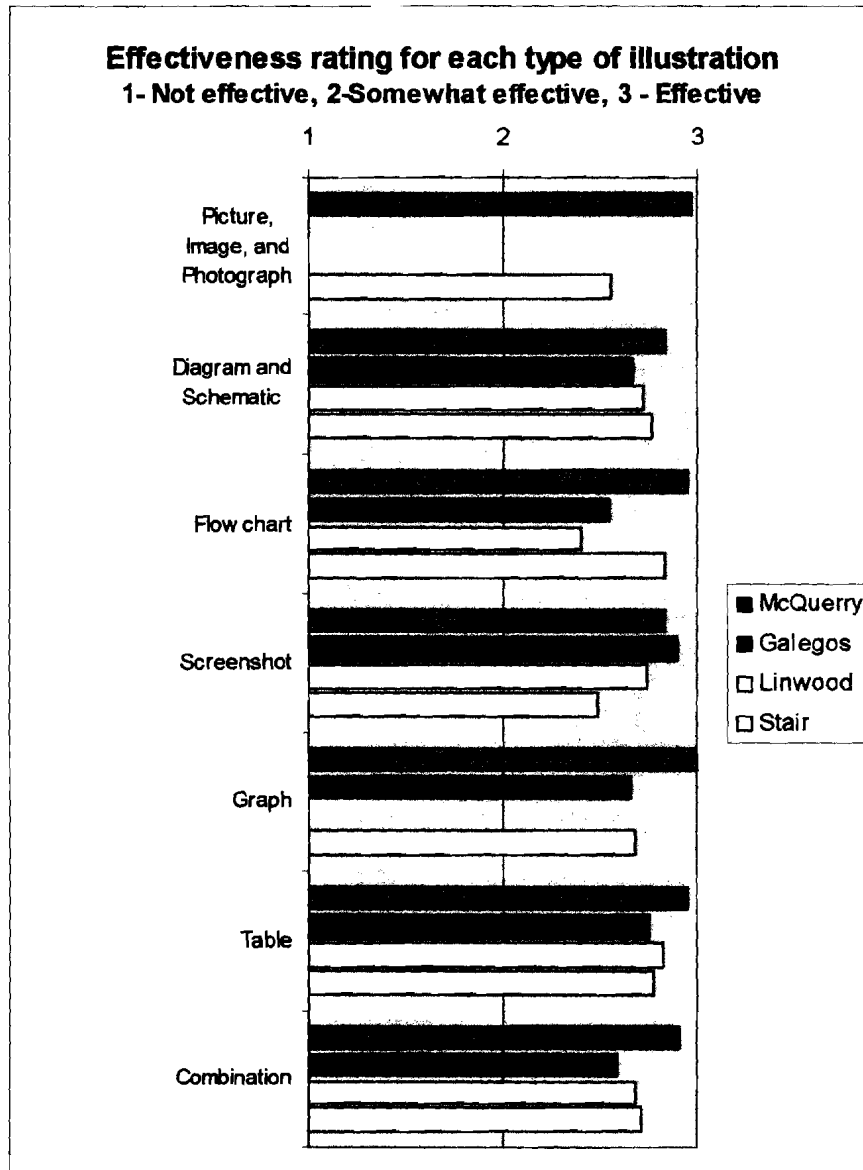

Figure 22. Effectiveness rating for each category.

The results of the effectiveness rating scale for each category indicating the mean, standard deviation, and statistical significance (p) at .05 (95% confident that the data did not happen by chance) has been calculated and displayed in Table 5.

Table 6

Effectiveness statistics for each category

Category	Mean	Standard Deviation	Significance at p = .05
Picture, Image, and Photograph	2.77	.29	None
Diagram and Schematic	2.75	.07	None
Flowchart	2.69	.25	None
Screenshot	2.74	.18	None
Graph	2.78	.19	None
Table	2.82	.09	None
Combination	2.72	.13	None

Item number five of the data collected from the rating scale is the overall effectiveness rating of individual textbooks by averaging all categories, and comparison of individual textbooks. The resulting data is displayed in the graph in Figure 23.

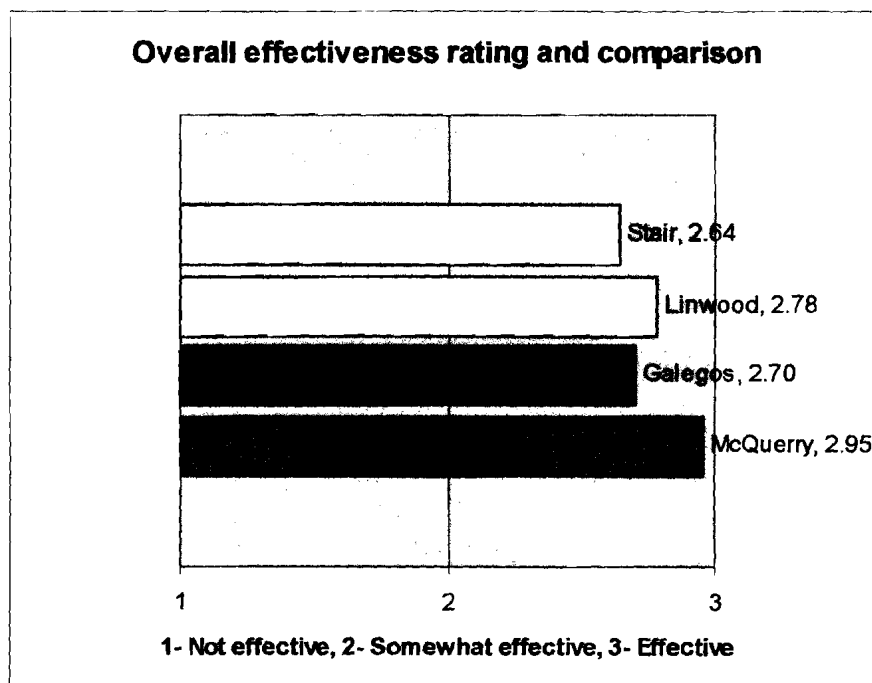

Figure 23. Overall effectiveness rating comparison.

The results indicated a range of 2.64 to 2.95 for the overall effectiveness rating between the textbook with the lowest score and the textbook with the highest score. The combined mean score was 2.77, with a standard deviation of .13. There was no significant difference found in the overall effectiveness rating between the textbooks ($p > .05$)

Discussion and Summary of Findings

Given the low number of textbooks for the sample, the mean and standard deviation method of statistics resulted in non-significant findings between the rating scale results. However, the range between the average percentage of illustrations among the lowest (14% - Galegos) and highest (58% - Stair) is significant. Likewise, the average illustration size between the lowest (32% - Stair) and highest (66% - Galegos) is significant ($p < .05$).

Galegos' Information Technology Control and Audit had the fewest number of illustrations (122) with the largest number of pages (849). Of the textbooks, Galegos had the lowest quality illustrations with instances of arrowheads cut off, misaligned elements, and text cut off, improperly abbreviated, or running outside the box. Other non-effective use of illustrations included intermittently placing information into tables rather than using bulleted text, and frequently using a table format without labeling it as such. The author labeled the illustrations exhibit 1, exhibit 2, etc. for each chapter. However, the labels were not consecutive throughout the book, and had no chapter designation. This textbook also had the highest number of illustrations that required the reader to flip the page between the text and illustration. Research indicates a greater variety of illustrations reach a higher number of learning styles and helps reinforce learning of the text. Galegos had the lowest number of illustrations and second lowest number of variety of illustrations.

On the positive side, Galegos' textbook had the highest ratings for interpretation (letting the reader know what to expect), use of captions to describe illustrations, matching the illustration level to the audience, good use of white space, and lack of crowding.

The next textbook, Stair's Principles of Information Systems, had the highest percentage of illustrations at 399 illustrations with 692 pages (58%). Stair also had the lowest overall effectiveness rating. The greatest factor in the low overall effectiveness rating was the large number of decorative illustrations, which usually do not enhance learning, but serve as decoration to make the textbook more attractive, increase sales, or attempt to make the material more interesting (Levin, 1981). The researcher also found that certain publishers often require a given percentage of illustration, regardless of effectiveness to enhancing learning of the textual material.

The confusion factor for Stair's textbook was high due to captions, illustrations, and definitions often times being crowded into the margins of the textbook. Other negative factors were the use of illustrations with captions, but no labeling or reference from the text, and poor placement of illustrations (too far from the text it represents).

Stair used a wide variety of illustrations to help explain text and enhance learning for a greater number of readers. Given the entry-level target audience, the illustrations matched very well. The overall illustration quality was very high, and the screenshot and photographs were clear and of good resolution.

The third textbook, Linwood's Convergence of Technologies, had a slightly below average amount of illustrations at 34% (185 illustrations / 548 pages). However, Linwood had slightly above average overall effectiveness at 2.78 on the 1-3 rating scale. The high

overall effectiveness rating was mainly due to creating effective diagrams and schematics (2.72), which made up 82% of all illustrations. The author occasionally used the same illustration image, or very similar images, to represent different devices, which added to the confusion factor. Many illustrations relied too much on the textual description, which reduced the effectiveness rating due to the lower standalone factor. There were many instances where the text alone was enough to describe the topic, and using an illustration was not necessary. The high effectiveness rating for good placement and proximity helped to offset the lower score for the lack of proper labeling when referring to illustrations.

The final textbook, McQuerry's CCNA Self-Study, received the highest overall rating with 2.95 out of a possible 3.0, and consistently had the highest ratings in the general category. The textbook had 290 illustrations out of 508 pages for a close second highest percentage of illustrations (57% to Stair's 58%). Ratings in all illustration categories were above average. The textbook was the only one of the sample to utilize a legend in the introduction introducing the icons with labels used in the book. However, many new icons, not identified in the introduction or on any other legends were used frequently, adding to the confusion factor.

Examples of effective and somewhat effective illustrations from each category along with the effectiveness rating and rationale can be found in appendix B.

Chapter V: Summary, Conclusions, and Recommendations

Introduction

This chapter will begin with a summary of the study, followed by general conclusions. The chapter will conclude with a discussion of recommendations.

Summary

Restatement of the Problem

Research confirms the effectiveness of combining text and illustrations in instructional media to promote enhanced learning. However, many authors, publishers, and educators who select textbooks for courses they teach, may not recognize what constitutes relevant, quality illustrations, or consider the tangible effect the illustrations have on learning.

Purpose of the Study

The primary purpose of this study was to develop criteria for determining effective use of illustrations in educational media. The secondary purpose was to analyze the illustrations in the textbooks required for the networking emphasis component of the Information and Communications Technologies program during the 2006-2007 academic school year at the University of Wisconsin-Stout. Another goal was to provide valuable information regarding the effectiveness of illustrations in textbooks, and assist in determining criterion for selection of textbooks for future courses.

The summary will continue in the form of conclusions addressing the research questions addressed in the study.

Conclusions

Addressing the research questions will provide conclusive information regarding the findings of the study. The following research questions were addressed in this study.

1. *What is the definition of visual imagery, and its correlation to illustrations, in the context of an educational textbook?*

The initial investigation into the definition of visual imagery resulted in a wide variety of definitions. Several technical writing books and cognitive psychology research studies defined visual imagery and illustrations as photographs, images, and schematics, with text used only for labeling purposes. Flowcharts and tables were considered text, rather than illustrations. The majority of information read by the researcher led to the definition of visual imagery to include pictures, diagrams, graphs, and schematics.

Additional definitions of visual imagery as they applied to student learning preferences for textbook applications included symbols, tables, charts, shapes, process charts or flow diagrams, and computer generated images known as screen captures. Many of these visual imagery expressions share the same meaning and may be interchangeable. However, in order to simplify and clarify the study, the term illustration was used when referring to any visual imagery expressions as described above. The American Heritage® Dictionary defined illustration as “material used to clarify or explain” (2000b, n.p.).

2. *What is the role of cognitive psychology in the development of effective illustrations?*

Developing effective illustrations require an understanding of how people respond to visual stimuli intended to enhance learning or aid text in comprehension of a topic. Simply looking at an illustration in a textbook invokes a highly sophisticated mental

processing system, and understanding how this system functions can help in creating effective illustrations. Cognitive psychology is the branch of psychology studying the mental processes involved in perception, learning, memory, and reasoning. Researchers sought answers to why certain types of illustrations were more effective than others, and what purpose the individual types of illustrations served. Illustrators and authors have relied on findings of cognitive research to create effective illustrations.

4. *What constitutes an effective versus non-effective illustration?*

Cognitive psychology and learning style research demonstrated the advantages of including illustrations in educational media. However, to be effective, the illustrator must consider their particular purpose and the abilities and preferences of the intended readers. General audiences are likely to favor illustrations such as basic tables, diagrams, or graphs that direct their center of attention and interpret key points of the information. Expert audiences are likely to favor flowcharts, complex graphs, numerical tables, or schematics that enable them to interpret the information for themselves. Illustrations should serve to compliment text, and aid in reading to learn, rather than being decorative, difficult to interpret, or distracting.

5. *Which criteria will be useful in development of a rating scale for effective textbook illustrations?*

Development of the rating scale was based in part on findings from cognitive psychology and learning style research as it relates to enhancing learning by combining visual imagery with textual content. In-depth study of experts' publications from technical writing, technical communication, graphic illustration, and graphic information areas were gathered and combined with the cognitive and learning style research element to help

design the criteria for the instrument. The researcher designed the rating scale based on at least two disciplines concurrence of what constitutes effective illustrations, with at least two sources from each discipline in agreement. Development consisted of three components for rating illustrations. The first was general guidelines that pertained to all illustrations. The second covered common elements, which may or may not apply to any or all of the illustrations, where some illustrations may incorporate multiple common elements. The third component addressed specific illustration types. Details of these components can be found in the effectiveness rating scale found in appendix A.

6. How do the illustrations in the textbooks used for the networking emphasis component of the ICT program at UW-Stout measure on the developed rating scale?

The following list consists of the seven categories of illustrations rated, along with the average overall score, and standard deviation (μ). The effectiveness ratings are based on a Likert scale with the following definitions: One – not effective, Two – somewhat effective, and Three – effective. Graphs and individual details can be found in chapter four.

- a. Pictures, images, and photographs – 2.77, μ .29
- b. Diagrams and schematics – 2.75, μ .07
- c. Flowcharts – 2.69, μ .25
- d. Screenshots – 2.74, μ .18
- e. Graphs – 2.78, μ .19
- f. Tables – 2.82, μ .09
- g. Combination – 2.72, μ .13

7. *Is there a significant difference in the rating between textbooks from varying authors or publishers?*

The overall effectiveness rating of the textbooks indicated a range of 2.64 to 2.95 between the textbook with the lowest score and the textbook with the highest score. The combined mean score was 2.77, with a standard deviation of .13. With $p = .05$, there was no significant difference found in the overall effectiveness rating between the textbooks.

Recommendations

The primary purpose of this study was to develop criteria for determining effective use of illustrations in educational media. In doing so, the researcher developed an effectiveness rating scale to rate seven categories of textbook illustrations. Due to time and resource limitations, the researcher was only able to rate the textbooks for one emphasis area of one program. In order to verify the validity and reliability of the rating scale, the researcher recommends further study. Areas of further investigation may include:

1. Analyzing a larger sample size; rating textbook illustration effectiveness from several emphasis areas of a program.
2. Rating textbook illustration effectiveness in programs other than the information technology discipline to eliminate any bias by the researcher.
3. Conducting a study to determine the validity of the rating scale by measuring correlation statistics between rated textbooks and student academic achievement.
4. Develop illustrations using the findings of this study, and conduct empirical research on a smaller scale, such as measuring student learning on a given topic with a control group using the developed illustrations combined with text, and another group using illustrations rated below average, combined with the same text.

Other things the researcher would have done differently given the chances to improve the study are:

1. Include a category on the rating scale to measure profiling. We live in a global society, where students come from all over the world, are different shapes and sizes, and of course, both genders. Illustrations containing photographs may use stereotypes of race, culture, and gender for given professions or status levels, and often use models that do not represent a typical cross-section of people.

2. The rating scale point system could be changed to allow for larger deductions for particular items that decrease the illustration effectiveness. For example, a particular illustration had an arrow in a flowchart pointing the wrong way, creating a confusing situation, and if followed would produce non-usable results and misinformation. The critical error was simply averaged into the total. Since the rest of the illustration met the effectiveness criteria, it was rated above average for effectiveness.

3. Finally, the researcher would have placed more emphasis on the study and use of color in illustration effectiveness. As research indicated, color hue, saturation, and variety affect the reader at various levels. In part, the decision to hold back on color research was due to the criteria for this study, requiring all graphics and text be printed in grey scale, thus limiting illustration effectiveness.

References

- Arnheim, R. (1982). *The power of the center: A study of composition in the visual arts*. Berkeley, CA: University of California Press.
- American Psychological Association. (2001). *Publication manual of the American psychological association, 5th ed.* Washington, DC: American Psychological Association.
- Balter, M. (2006). Radio carbon dating's final frontier. *Science*, 313(5793), 1560-1563.
- Barbe, W. B., & Malone, M. N. (1981). What we know about modality strengths. *Educational Leadership*, 2, 378-380.
- Bartlett, L. E. (1991). *Choosing the college textbook: A textbook selection checklist for instructor use. Curriculum and planning*. (ERIC Document Reproduction Service No. ED 365 197)
- Benson, P. J. (1997). Problems in picturing text: A study of visual/verbal problem solving. *Technical Communication Quarterly*, 6(2), 141.
- Bertin, J. (1983). *Semiology of graphics: Diagrams, networks, maps*. W. J. Berg (trans.) Madison, WI: University of Wisconsin Press.
- Brasseur, L. (1993). The visual composing process of graph, chart, and table designers: Results of an empirical. In B.Sims (Ed). *Studies in technical communication* (pp. 163-182). Denton, TX: University of North Texas.
- Brasseur, L. E. (2003). *Visualizing technical information: A cultural critique*. Amityville, NY: Baywood Publishing.
- Card, S. K., Mackinlay, J. D., & Sheiderman, B. (Eds.). (1999). *Readings in information visualization: Using vision to think*. San Francisco, CA: Morgan Kaufmann.

- Carney, R. N., & Levin, J. R. (2002). Pictorial illustrations still improve student's learning from text. *Educational Psychology Review*, 14(1), 5-26.
- Carpenter, P. A., & Shaw, P. (1998). A model of the perceptual and conceptual processes in graph comprehension. *Journal of Experimental Psychology: Applied*, 4, 75-100.
- Casali, J., & Gaylin, K. (1988). Selected graph design variables in four interpretation tasks: A microcomputer-based pilot study. *Behavior and Information Technology*, 7, 31-49.
- Dunn, R. (2000). Learning styles: Theory, research, and practice. *National Forum of Applied Educational Research Journal*, 13(1), 3-22.
- Dunn, R., & Dunn, K. (1993). *Teaching secondary students through their individual learning styles: Practical approaches for grades 7-12*. Boston: Allyn & Bacon.
- Dunn, R., & Dunn, K. (1999). *The complete guide to the learning styles inservice system*. Boston, MA: Allyn & Bacon.
- Dunn, R., Dunn, K., & Price, G. E. (1990). *Productivity environmental preference survey*. (Available: Price Systems, Box 1818, Lawrence, KS 66044)
- Eysenck, M. W., & Keane, M. (2000). *Cognitive psychology: A student's handbook* (4th ed.). Philadelphia, PA: Psychology Press
- Felder, R. M., & Spurlin, J. (2005). Applications, reliability and validity of the index of learning styles. *International Journal of Engineering Education*, 21(1), 103-112.
- Fleming, N. D., & Mills, C. (1992). Not another inventory, rather a catalyst for reflection. *To Improve the Academy*, 11, 137-144.
- Galegos, F., Senft, S., Manson, D. P., & Gonzales, C. (2004). *Information technology control and audit* (2nd ed.). Boca Raton, FL: Auerbach Publications.

- Gardner, H. (1983). *Frames of mind: The theory of multiple intelligences*. New York: Basic Books.
- Geisert, G., & Dunn, R. (1991). Computers and learning styles. *Principal*, 70, 47.
- Harp, S. F., & Mayer, R. E. (1997). The role of interest in learning from scientific text and illustrations: On the distinction between emotional interest and cognitive interest. *Journal of Educational Psychology* 89(1), 92-102.
- Harris, R. L. (1996). *Information graphics: A comprehensive illustrated reference*. Atlanta, GA: Management Graphics.
- Haydon, L. M. (1995). *The complete guide to writing & producing technical manuals*. New York: John Wiley & Sons.
- Knowles, M. (1998). *Adult learner: The definitive classic in adult education and human resource development*. Houston, TX: Gulf Publishing Company.
- Kosslyn, S. M., Thompson, W. L., & Ganis, G. (2006). *The case for mental imagery*. New York, NY: Oxford University Press.
- Kress, G. (1997). Visual and verbal modes of representation in electronically mediated communication: the potentials of new forms of text. *Taking literacy into the electronic era*. Snyder (Ed.), Sydney: Allen and Unwin.
- Lannon, J. M. (2000). *Technical communication*, (8th ed.). Reading, MA: Longman.
- Levin, J. R. (1981). On the functions of pictures in prose. In F. J. Pirozzolo & M. C. Wittrock (Eds.), *Neuropsychological and cognitive processes in reading* (pp. 203-228). San Diego, CA: Academic Press.
- Linwood, R., Sawyer, T. K., & Watts, D. (2004). *Convergence of technologies: Integrating networks for multimedia solutions*. Arvada, CO: Westnet Learning.

- Lynch, M. (1990). The externalized retina: Selection and mathematization in the visual documentation of objects in the life sciences. In M. Lynch & S. Woolgar (Eds.), *Representation in scientific practice* (pp. 153-186). Cambridge, MA: The MIT Press.
- Mayer, R. E. (1989). Systematic thinking fostered by illustrations in scientific text. *Journal of Educational Psychology, 81*(2), 240-246.
- Mayer, R. E., & Gallini, J. K. (1990). When is an illustration worth ten thousand words? *Journal of Educational Psychology, 82*(4), 715-726.
- McQuerry, S. (2004). *CCNA self-study: Introduction to cisco networking technologies*. Indianapolis, IN: Cisco Press.
- Mills, D. Q. (1978, August 9). A collision course on energy policy. *The New York Times*, p. D-2.
- Morton, J. (1969). Interaction of information in word recognition. *Psychological Review, 76*, 165-178.
- Paivio, A. (1971). *Imagery and verbal processes*. New York: Holt, Rinehart & Winston.
- Paivio, A. (1991). Dual coding theory: Retrospect and current status. *Canadian Journal of Psychology, 45*(3), 255-287.
- Paivio, A., Clark, J. M., & Lambert, W. E. (1988). Bilingual dual-coding theory and semantic repetition effect on recall. *Journal of Experimental Psychology: Learning, Memory, and Cognition, 14*, 163-172.
- Pettersson, R. (1993). *Visual information: Second edition*. Englewood Cliffs, NJ: Educational Technology Publications.

- Sadoski, M., Goetz, E. T., & Rodriguez, M. (2000). Engaging texts: Effects of concreteness on comprehensibility, interest, and recall in four text types. *Journal of Educational Psychology, 92*, 85-95.
- Scarazzo, S. (2006). *College freshman increasingly unprepared: New textbook supplements helping students succeed*. Retrieved January 28, 2007, from: www.publishers.org/press/releases.cfm?PressReleaseArticleID=349
- Schnotz, W. (2002). Towards an integrated view of learning from text and visual displays. *Educational Psychology Review, 14*(1), 101-120.
- Schrivver, K.A. (1997) *Dynamics in documentation design*. New York, NY: John Wiley and Sons.
- Stair, R. M., Reynolds, G. W. (2003). *Principles of information systems, a managerial approach* (6th ed.). Boston, MA: Course Technology.
- The American heritage® dictionary of the English language, Fourth Edition. (2000a). *diagram*. Retrieved March 5, 2007, from: dictionary.reference.com/browse/diagram
- The American heritage® dictionary of the English language, Fourth Edition. (2000b). *illustration*. Retrieved March 27, 2007, from: dictionary.reference.com/browse/illustration
- The American heritage® dictionary of the English language, Fourth Edition. (2000c). *picture*. Retrieved March 27, 2007, from: dictionary.reference.com/browse/picture
- The American heritage® dictionary of the English language, Fourth Edition. (2000d). *shapes*. Retrieved March 15, 2007, from: dictionary.reference.com/browse/shapes

- The American heritage® dictionary of the English language, Fourth Edition. (2000e).
table. Retrieved March 5, 2007, from: dictionary.reference.com/browse/table
- The American heritage® science dictionary. (2002a). *graph*. Retrieved April 2, 2007,
from: dictionary.reference.com/browse/graph
- The American heritage® science dictionary. (2002b). *symbols*. Retrieved March 15, 2007,
from: dictionary.reference.com/browse/symbols
- Tufte, E. R. (2001). *The visual display of quantitative information*. Cheshire, CT: Graphics Press.
- Tufte, E. R. (2006). *Beautiful evidence*. Cheshire, CT: Graphics Press LLC.
- Uffenbeck, J. E. (1982). *Introduction to electronics: Devices and circuits*. Englewood Cliffs, NJ: Prentice Hall
- Uffenbeck, J. E. (1987). *The 8086/8088 family: Design, programming, and interfacing*. Englewood Cliffs, NJ
- University of Wisconsin-Stout. (2007a). *About the university*. Retrieved January 17, 2007,
from: www.uwstout.edu/geninfo/facts.shtml
- University of Wisconsin-Stout. (2007b). *About the university*. Retrieved January 17, 2007,
from: www.uwstout.edu/geninfo/welcome.shtml
- Webster's new millennium™ dictionary of English, Preview Edition (v 0.9.6; 2006).
screen shot. Retrieved April 1, 2007, from: [dictionary.reference.com/browse/screen shot](http://dictionary.reference.com/browse/screen-shot)
- Willows, D. M., & Houghton, H. A. (1987). *The psychology of illustration. Volume 1: Basic research*. New York, NY: Springer-Verlag.

Wordnet® 3.0. (2007). *picture*. Retrieved April 5, 2007, from:
dictionary.reference.com/browse/picture

Appendix A: Illustration rating scale instrument

There are three components for rating illustrations. The first is general guidelines that pertain to all illustrations. The second covers common elements, which may or may not apply to any or all of the illustrations, and some illustrations may incorporate multiple common elements. The third component addresses specific illustration types.

The rating scale will utilize a Likert scale with a 1-3 rating, with 1 indicating not effective, 2 – somewhat effective, and 3 indicating effective.

General Guidelines

The following general guidelines were developed to rate all illustrations:

1. Proximity – The illustration should be placed as close as possible to the text it clarifies, should be easy for the reader to locate, and positioned following the first text reference to it. The reader should not have to turn to the preceding or proceeding page to view the illustration.

<u>Two or more pages apart</u>	<u>Need to flip one page</u>	<u>Same page or no flip</u>
1	2	3

2. Crowding - Frame the illustration with enough white space around the border for ease of viewing.

<u>No white space or border</u>	<u>Slight crowding</u>	<u>Enough white space</u>
1	2	3

3. Label – Use a number, clear title, and label, to identify the illustration.

<u>Two or more elements missing</u>	<u>One element missing</u>	<u>All three present</u>
1	2	3

4. Audience – Match the illustration to your target audience. Do not make it too complex for non-specialists or too elementary for specialists.

<u>Does not match</u>	<u>Somewhat hard/easy to interpret</u>	<u>Illustration matches</u>
-----------------------	--	-----------------------------

1

2

3

5. Interpret – Introduce the illustration in the text, and advise readers what to expect. Use illustration label, do not use “see table below” or “the following table.”

<u>Missing two or more elements</u>	<u>Missing one element</u>	<u>All three present</u>
1	2	3

6. Captions – Use prose captions to explain major points made by the illustration. Use a smaller type size, as not to compete with the surrounding text, and distinguish item labels from descriptive text using bold, space, or different size font.

<u>Missing both elements</u>	<u>Missing one element</u>	<u>All three present</u>
1	2	3

7. Confusion Factor – The illustration should use the proper amount of elements (seven should be the maximum), be relatively easy to interpret, and be uncluttered.

<u>Missing all three elements</u>	<u>Missing one element</u>	<u>All three present</u>
1	2	3

8. Stand-alone Factor – The illustration should be descript, and include enough data to be understood without the need to revert back and forth to the text for clarification.

<u>Unclear</u>	<u>Somewhat clear</u>	<u>Could stand alone</u>
1	2	3

Common Elements

The following guidelines were developed for rating common elements such as legends or keys, arrows, clip art, or use of analogies. Improper use of these elements may render an illustration less effective. These elements fall under the general guidelines criteria, as they may or may not be used with the various illustration types. Therefore, points will be deducted from the general guidelines category for improper use of the

element, rather than added to the total score. Since there are eight general guidelines, the point deductions will be 1/8 and 1/16 points.

1. Legends or Keys - For a key to be effective, it must identify what the data graphics represent, such as symbols or icons; indicate certain characteristics of the item represented, and enable readers to estimate quantitative values.

<u>Legend/Key missing</u>	<u>One of three criteria followed</u>	<u>All three followed</u>
.125	.0625	0

2. Arrows - To be effective, arrow and line density should not stand out above the graphics they represent or connect, but act as a flow mechanism.

<u>No arrow use</u>	<u>One of two criteria followed</u>	<u>Both criteria followed</u>
.125	.0625	0

3. Clip Art - Some illustrators find clip art effective as icons or symbols, where others suggest it has a generic, crude, or unprofessional look, and may have only decorative value.

<u>Unprofessional, no relevance</u>	<u>Somewhat professional</u>	<u>Used effectively</u>
.125	.0625	0

4. Analogy – If the illustration uses an analogy to explain or visualize the concept, the analogy should be relevant to the target audience, and not generational, cultural, or non-topical.

<u>Not relevant</u>	<u>Somewhat relevant</u>	<u>Relevant</u>
.125	.0625	0

The following guidelines are more specific and target individual types of illustrations.

Pictures, Images, and Photographs

When using or rating pictures, photographs, or images, follow these guidelines:

1. Type – Consider whether a hand drawn or computer rendered picture may be more effective than a photograph.

<u>Photo not appropriate</u>	<u>Somewhat appropriate</u>	<u>Appropriate</u>
1	2	3

2. Relevance – The image should be representational of the topic or information presented.

<u>Image does not represent topic</u>	<u>Somewhat represents topic</u>	<u>Represents topic</u>
1	2	3

3. Clarity – The image must have clear, sharp lines, and be large enough to reveal locations of distinct basic parts and their characteristics.

<u>Blurry or unclear</u>	<u>Somewhat clear</u>	<u>Good clarity</u>
1	2	3

4. Angle – The image should be illustrated at approximately the same angle that the readers would use while performing a procedure or identifying components.

<u>Wrong angle</u>	<u>Angle somewhat appropriate</u>	<u>Clear view, good angle</u>
1	2	3

5. Cropping – Crop or trim the image to eliminate unnecessary details.

<u>Too many details</u>	<u>Somewhat cluttered</u>	<u>Image detail sufficient</u>
1	2	3

6. Scale – If the image is unfamiliar to the reader, a familiar object or a ruler should be included to give a sense of scale.

<u>Object unfamiliar, no scale</u>	<u>Somewhat familiar, no scale</u>	<u>Familiar, or scale used</u>
1	2	3

Diagrams and Schematics

When using or rating diagrams or schematics, follow these guidelines:

1. Type – Consider whether to use an exploded, cutaway, or block diagram. For ease in identifying individual parts, an exploded diagram is best. Use a cutaway view for illustrating internal or hidden parts. A block diagram or schematic will help present conceptual elements of a principle or aid in developing mental models of abstract concepts.

<u>Diagram/schematic inappropriate</u>	<u>Somewhat appropriate</u>	<u>Appropriate</u>
1	2	3

2. Labeling – The image should use lines and text labels to identify its parts. If the image has many parts, a numbering scheme and parts list will help eliminate clutter.

<u>Not labeled</u>	<u>Cluttered labeling</u>	<u>Appropriately labeled</u>
1	2	3

3. View - If the view is not immediately recognizable, the angle should be labeled as “top view,” “side view,” and so on.

<u>Cannot recognize</u>	<u>Somewhat recognizable view, missing label</u>	<u>Appropriate</u>
1	2	3

4. Concept – Block diagrams should properly use blocks, arrows, and text to demonstrate a flow or cause-and-effect to explain or clarify a concept.

<u>Unclear concept</u>	<u>Somewhat clear</u>	<u>Clear concept</u>
1	2	3

Flowcharts

When using or rating flowcharts, follow these guidelines:

1. Shapes - There are standard shapes, also called symbols, boxes, enclosures, or blocks that represent the various functions of flowcharts.

<u>Non-standard shapes</u>	<u>Most standard shapes</u>	<u>Standard shapes</u>
1	2	3

2. Flow - For a flowchart to be effective, it must include logical, guided steps to direct the reader through a logical process or sequence of events. The flowchart must not be open-ended, or leave the reader without direction.

<u>Hard to follow, open ended</u>	<u>Somewhat hard to follow</u>	<u>Logical, easy to follow</u>
1	2	3

Screenshots

When using or rating screenshots, follow these guidelines:

1. Type - Display the sub-window or portion of the screenshot that pertains to the relevant content, rather than the whole screen.

<u>Whole screen used unnecessarily</u>	<u>Poor cropping</u>	<u>Proper sub-window</u>
1	2	3

2. Clarity – Screenshots should be high enough resolution to offer clear detail when reduced to fit allotted space.

<u>Unclear</u>	<u>Somewhat clear</u>	<u>Good clarity</u>
1	2	3

Graphs

When using or rating graphs, plots, or data charts, follow these guidelines:

1. Distortion - Avoiding distortion is important in creating effective graphs.

<u>Image does not match data</u>	<u>Somewhat distorted for effect</u>	<u>Image matches data</u>
1	2	3

2. Context - Encourage the eye to compare different sets of data. In other words, the reader must ask, “Compared to what?”

<u>Data exaggerated, no reference</u>	<u>Somewhat exaggerated</u>	<u>Presented in context</u>
1	2	3

3. Chartjunk - Encourage the reader to think about the substance of the graph, rather than methodology, design, technology, or “something else,” described as chartjunk.

Chartjunk, sometimes called clutter, is described as things included in graphs and charts that are not vital to the understanding, and may detract from their main intention.

<u>Too much chartjunk</u>	<u>Chartjunk appropriate for effect</u>	<u>No chartjunk</u>
1	2	3

4. General - Graphical displays should make large data sets coherent and reveal the data at several levels of detail, from a broad overview to the fine structure. This was accomplished by following three main processes while interpreting the graphs. First, identify the important visual features, such as the slant of the curve or line. Next, identify the relationship between the quantitative facts (e.g., the increase or decrease in the relationship between x and y). Finally, correlate the relationship of x and y to the variables given, such as year versus population.

<u>No processes followed</u>	<u>One of three followed</u>	<u>All three followed</u>
1	2	3

Tables

When using or rating tables, follow these guidelines:

1. Title - The table typeface should be non-serif and 1 to 1.5 points smaller than the surrounding text. The title should be a brief and concise description of what the table represents. If the title must be longer, the use of an asterisk and a footnote should be considered.

<u>Missing all three elements</u>	<u>Missing one element</u>	<u>All three present</u>
1	2	3

2. Format - The boxhead contains the column headings in bold text. The left hand vertical column, or stub, lists the items about which information is given in the body of the table. The body contains the data below the boxhead and to the right of the stub, and should be arranged so the items in the stub appear adjacent.

<u>Missing all three elements</u>	<u>Missing one element</u>	<u>All three present</u>
1	2	3

Combinations

When using or rating illustrations that use combinations of two or more illustration types, follow these guidelines:

1. Overall – Combination illustrations must be rated using an overall effectiveness rating involving application of general and individual criteria.

<u>Not effective</u>	<u>Somewhat effective</u>	<u>Effective</u>
1	2	3

Appendix B: Illustration rating examples

This appendix contains examples of the textbook illustrations rated using the illustration effectiveness instrument from appendix B. The illustrations are displayed by category, with a table showing the score with rationale for the score from the general guidelines, common elements, and specific illustration type criteria, followed by the overall effectiveness rating.

The rating scale utilized a Likert scale with a 1-3 rating, with 1 indicating not effective, 2 – somewhat effective, and 3 indicating effective.

The illustration in Figure 24 represents a somewhat effective illustration from the pictures, images, and photograph category.

<p>data warehouse a database that collects business information from many sources in the enterprise, covering all aspects of the company's processes, products, and customers</p>	<p>Data Warehouses A data warehouse is a database that holds business information from many sources in the enterprise, covering all aspects of the company's processes, products, and customers. The data warehouse provides business users with a multi-dimensional view of the data they need to analyze business conditions. A data warehouse is designed specifically to support management decision making, not to meet the needs of transaction processing systems. The data warehouse provides a specialized decision support database that manages the flow of information from existing corporate databases and external sources to end-user decision support applications. A data warehouse stores historical data that has been extracted from operational systems and external data sources (Figure 5.18). This operational and external data is "cleaned up" to remove inconsistencies and integrated to create a new information database that is more suitable for business analysis.</p>
<p>Sears's data warehouse is enormous—and growing. When completed, it will contain roughly enough information to fill 20 million four-drawer filing cabinets. (Source: © Syracuse Newspapers/Deere; NellThe Image Works.)</p>	<p>Data warehouses typically start out as very large databases, containing millions and even hundreds of millions of data records. As this data is collected from the various production systems, a historical database is built that business analysts can use.</p> <p>To remain fresh and accurate, the data warehouse receives regular updates. Old data that is no longer needed is purged from the data warehouse. Updating the data warehouse must be fast, efficient, and automated, or the ultimate value of the data warehouse is sacrificed. It is common for a data warehouse to contain from 3 to 10 years of current and historical data. Data cleaning tools can merge data from many sources into one database, automate data collection and verification, delete unwanted data, and maintain data in a database management system. The amount of data the average business collects and stores is doubling each year. If that holds true at a company such as Sears, Roebuck and Co., which is combining its customer and inventory data warehouses to create</p>
	

Figure 24. Somewhat effective picture illustration

Table 7

Somewhat effective picture illustration results

General Guidelines	Rating	Rationale
Proximity	3	The illustration follows closely to the text it is meant to clarify, and easy for the reader to locate.
Crowding	2	The illustration utilizes less white space than the average illustration in the textbook, and is somewhat crowded into the margin.
Label	1	No use of a number, title, or label to identify the illustration.
Audience	2	The illustration is somewhat elementary, decorative, and does not match the target audience level.
Interpret	1	There is no introduction of the illustration, and no text advising readers what to expect in the illustration.
Captions	1	The caption does not describe the major points made by the illustration.
Confusion Factor	1	The illustration is cluttered, and difficult to interpret. The caption and text discuss a large database called a data warehouse, and the number of filing cabinets it represents; and the illustration depicts a mall storefront.
Stand-alone Factor	2	The illustration and caption require the reader to search for clarification in the text.
Common Elements		No deduction for common element misuse.
Picture, Image, and Photograph category		
Type	2	The text and caption describe a large database. The normal illustration type for a database is a screen capture, or picture of a database in use on a computer screen.
Relevance	1	The image does not represent the topic presented.
Clarity	2	The storefront logo is clear, but the image lacks clear, sharp lines, and is somewhat small to identify characteristics.
Angle	3	The angle of the illustration is sufficient.
Cropping	2	The illustration is somewhat cluttered.
Scale	3	The image is familiar, and requires no scale object.

The overall rating for the picture illustration in Figure 24 averaged 1.86, or slightly less than somewhat effective. In comparison, Figure 25 and Table 8 represent an example of an effective picture illustration, with a 2.93 overall rating.

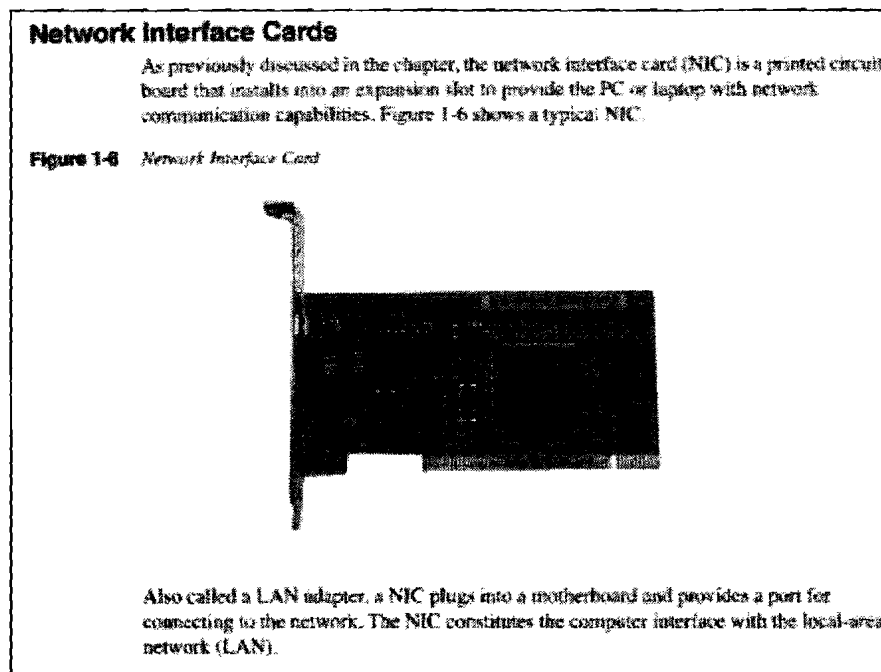

Figure 25. Effective picture illustration

Table 8

Effective picture illustration results

General Guidelines	Rating	Rationale
Proximity	3	The illustration follows the text it is meant to clarify, and easy for the reader to locate.
Crowding	3	The illustration utilizes the proper amount of white space.
Label	3	There is a number, clear title, and label identifying the illustration.
Audience	3	The illustration matches the target audience.
Interpret	3	The illustration is introduced by the text with a proper label, and advises the readers what to expect.
Captions	3	No caption necessary

Confusion Factor	3	The illustration is uncluttered.
Stand-alone Factor	3	The illustration and text clearly describe the item.
Common Elements	No deduction for common element misuse	
Picture, Image, and Photograph category		
Type	3	A photograph or computer generated image is appropriate.
Relevance	3	The image represents the topic presented.
Clarity	3	The picture shows clear, sharp lines.
Angle	3	The angle of the illustration represents what a technician would see looking at the component uninstalled.
Cropping	3	No unnecessary details.
Scale	2	The image should be familiar to the target audience, but lacks a sense of scale.

Figure 26 and Table 9 represent a somewhat effective illustration from the diagram and schematic category.

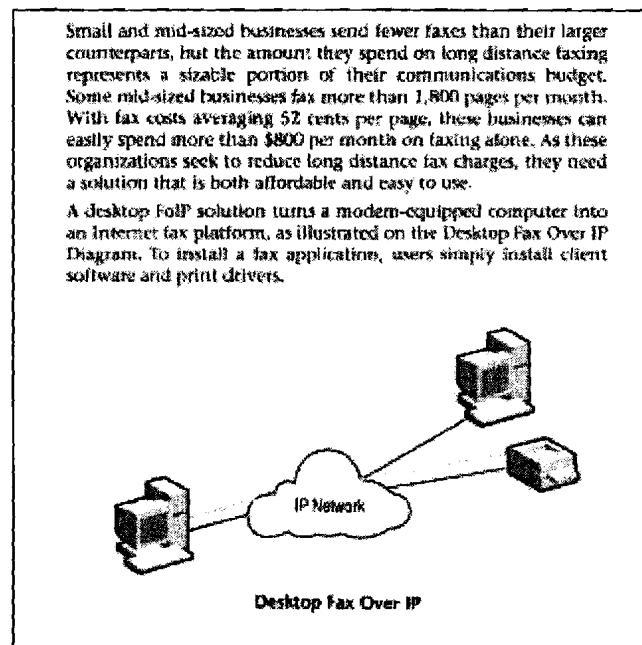

Figure 26. Somewhat effective diagram illustration

Table 9

Somewhat effective diagram illustration results

General Guidelines	Rating	Rationale
Proximity	3	The illustration follows the text it is meant to clarify, and easy for the reader to locate.
Crowding	3	The illustration utilizes the proper amount of white space.
Label	1	There is a title, but no number or label identifying the illustration.
Audience	3	The illustration matches the target audience.
Interpret	2	The illustration is introduced by the title as a modern-equipped computer turning into a Internet fax platform, but the schematic displays standard, previously used generic computer icons.
Captions	1	No caption to explain points made by illustration
Confusion Factor	2	The illustration is uncluttered, but hard to interpret.
Stand-alone Factor	1	The illustration and text do not clearly describe the illustration.
Common Elements		
Key or Legend	-.125	Subtraction for lack of icon identification in key or legend.
Clipart	-.0625	Subtraction for generic icon.
Diagrams and Schematics		
Type	3	Computer generated schematic is appropriate.
Labeling	1	Components not labeled
View	3	View of illustration is appropriate
Concept	2	Concept somewhat unclear

The overall rating for the diagram illustration in Figure 26 averaged 1.90, or slightly less than somewhat effective. In comparison, Figure 27 and Table 10 represent an example of an effective diagram illustration, earning a 3.0 overall rating.

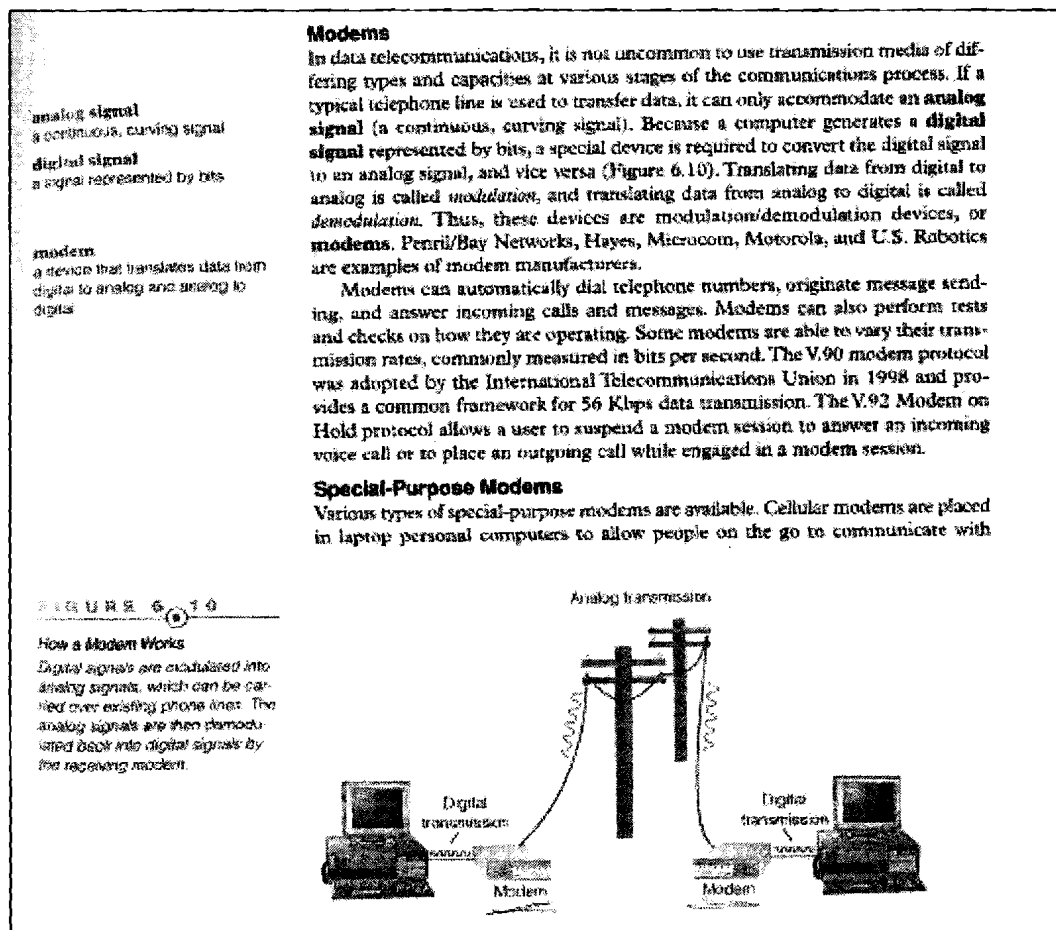

Figure 27. Effective diagram illustration

Table 10

Effective diagram illustration results

General Guidelines	Rating	Rationale
Proximity	3	The illustration follows the text it is meant to clarify, and easy for the reader to locate.
Crowding	3	The illustration utilizes the proper amount of white space.
Label	3	There is a title, label, and number identifying the illustration.
Audience	3	The illustration matches the target audience.
Interpret	3	The illustration is introduced by the text, and readers are advised what to expect.
Captions	3	The caption explains major points made by the illustration, and uses smaller text.

Confusion Factor	3	The illustration is uncluttered, and easy to interpret.
Stand-alone Factor	3	The illustration and caption contain enough data.
Common Elements		No deduction for common element misuse
Diagrams and Schematics		
Type	3	Computer generated schematic is appropriate.
Labeling	3	Components clearly labeled
View	3	View of illustration is appropriate
Concept	3	Concept of modem function clear

Figure 28 and Table 11 represent a somewhat effective illustration from the flowchart category.

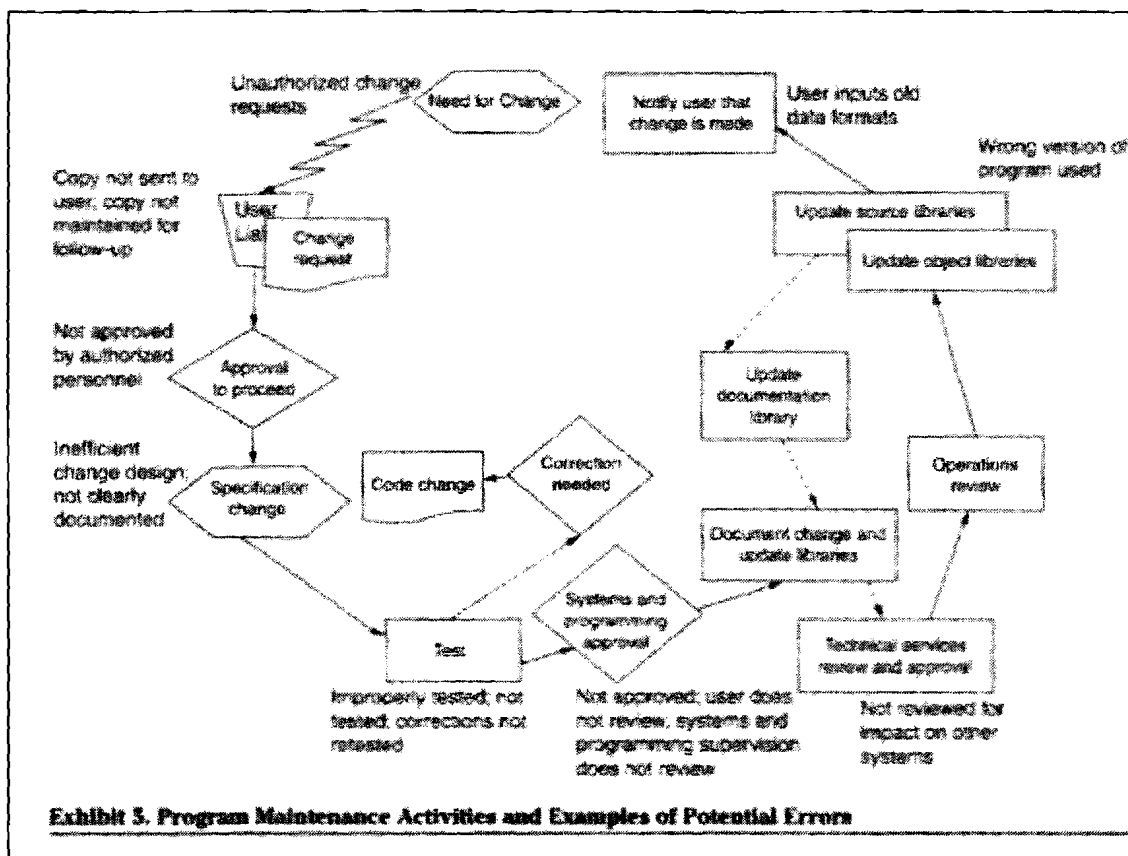

Figure 28. Somewhat effective flowchart illustration

Table 11

Somewhat effective flowchart illustration results

General Guidelines	Rating	Rationale
Proximity	2	The illustration follows the text it is meant to clarify, but the reader must flip the page to interpret complicated flowchart.
Crowding	3	The illustration utilizes the proper amount of white space.
Label	2	There is a title, label, and number identifying the illustration, but no designation for the chapter. Each chapter starts sequence over.
Audience	2	Somewhat hard to interpret, given the audience and previous flowcharts.
Interpret	2	The illustration is introduced by the text, but the interpretation does not readily match the flowchart text.
Captions	3	No caption necessary.
Confusion Factor	1	The illustration is cluttered with extra text and difficult to interpret.
Stand-alone Factor	2	The title and flowchart text are somewhat sufficient, but reader must flip to text.
Common Elements		
Arrows	.125	Deduction for non-standard arrow use (squiggly line, and no interpretation for dotted arrow leader)
Flowchart		
Shapes	2	Squiggly line and need for change box non-standard, plus standard end or termination box missing.
Flow	1	Reader left without direction with three open-ended boxes, and non-logical steps.

The overall rating for the flowchart illustration in Figure 28 averaged 1.88, less than somewhat effective. In comparison, Figure 29 and Table 12 represent an example of an effective flowchart, earning a 3.0 overall rating.

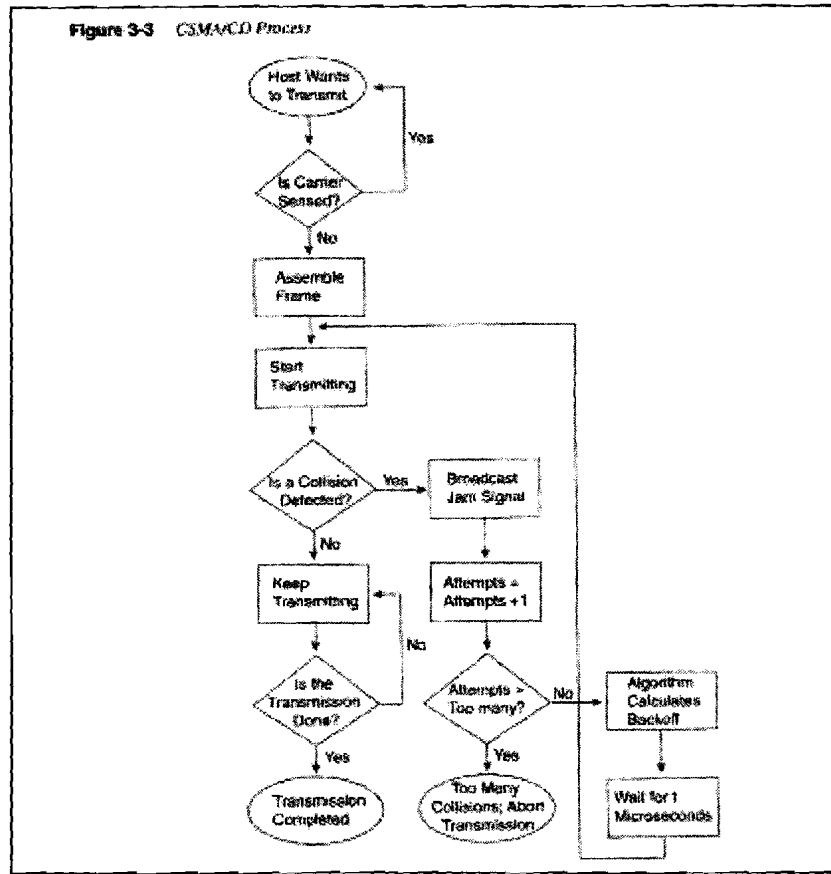

Figure 29. Effective flowchart illustration

Table 12

Effective flowchart illustration results

General Guidelines	Rating	Rationale
Proximity	3	The illustration follows the text it is meant to clarify, without flipping the page to understand.
Crowding	3	The illustration utilizes the proper amount of white space.
Label	3	There is a title, label, and number identifying the illustration.
Audience	3	The level and context of the information matches the reader.
Interpret	3	The illustration is introduced by the text, and the readers are advised what to expect.
Captions	3	No caption necessary.
Confusion Factor	3	The illustration is uncluttered and easy to interpret.

Stand-alone Factor	3	The flowchart and title are self-explanatory.
Common Elements		This illustration had no deduction for common element misuse
Flowchart		
Shapes	3	All standard shapes.
Flow	3	Logical, guided steps direct reader through process with explicit conclusion.

Figure 30 and Table 13 represent a somewhat effective illustration from the screenshot category.

... advertising options that Google offers allows... results, nor do they consume a high per... real estate. Because the advertisements... keywords, they are more likely to yield... sponsors. Overall, Google has developed a win... strategy that assists both its sponsors

Questions

... more for popular keywords than for less... how else might Google profit by recording... that are entered by users and tracking the... that are followed?

... advertising is too much? Everyone has a differ... of tolerance for advertising. What is your... tolerate one banner ad per Web page?... about pop-up advertisement windows?

Ending Questions

... types of Web sites, besides search engines... able to offer user-targeted advertising like... of the Web more likely to resemble network... of public TV? What exterior forces can be... the Web to be less commercial?

Three Dimensions

... Web browsers haven't changed much... for years. Mosaic was the first graphical Web... mostly by Netscape, and then Internet... early days, hundreds of Web browsers... and marketed, none able to compete... Netscape and Internet Explorer, but all fol... general framework as the original, start at... click hyperlinks to move to other Web pages... click the Back or Forward buttons to... Web pages that you have visited, click the... to return to your home page. We all know the... been little innovation in Web browsers—... a small company in Virginia released a... Browse3D.

... CEO of Browse3D Corp, David Shuping... the Internet, so he decided to make it more... can view one page at a time," Shuping said... saying, "You move one step forward and take... we were doing the same on the Web." So... Bill Johnson, along with four

the right wall is your possible future. The benefit is that you are able to actually see the pages, rather than just their text links. The left and right walls can be flipped to display nine more pages either further back in your history, or further ahead in your possible future.

Browse3D offers numerous other features. For instance, you can make a page "sticky" so that it is saved on a fourth wall for future reference during your browsing session. You can save collections of sticky pages for future reference either as static pages or active pages. Static pages are preserved in their current state so that if the page is updated on the Web, your saved static page remains unchanged. Active pages call up the current version of the page on the Web. Browse3D offers tools to rotate the virtual room, zoom in and out, or switch to a standard 2-D browser.

Browse3D offers a way for users to become more immersed in the Web-browsing experience by graphically viewing their past and future and quickly selecting the correct path to traverse. The beta version of this desktop product debuted at COMDEX in November 2001, where it was named "Best Internet Software" and generated interest from thousands of potential customers. Will Browse3D be the product that finally gives Internet Explorer and Netscape a run for their

Sources: James Lewin, "The Future of Web Advertising," February 5, 2002, <http://www.itworld.com>; Chris Sherman, "No, Google Haven't Sold Out," March 12, 2002, <http://siliconvalleyint.net.com>; Danny Sullivan, "Up Close With Google AdWords," March 4, 2002, <http://searchenginewatch.com>; Brian Sullivan, "Intrusive Ads: A Sign of Online Advertising Evolution, Analysts Say," February 19, 2002, <http://www.computerworld.com>; <http://www.google.com>, accessed March 25, 2002.

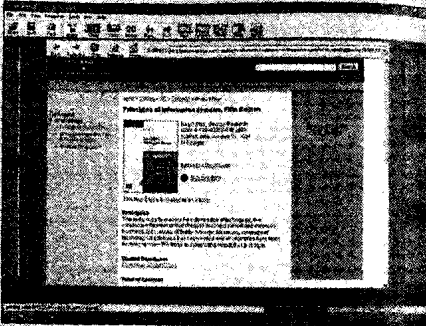

Figure 30. Somewhat effective screenshot illustration

Table 13

Somewhat effective screenshot illustration results

General Guidelines	Rating	Rationale
Proximity	3	The illustration follows the text it is meant to clarify, without flipping the page.
Crowding	3	The illustration utilizes the proper amount of white space.
Label	1	There is no title, label, or number identifying the illustration.
Audience	3	The level and context of the information matches the reader.
Interpret	1	The illustration is not introduced by the text, and the readers are left to assume the illustration is correct.
Captions	1	No caption.
Confusion Factor	2	The illustration is not cluttered, but is hard to interpret.
Stand-alone Factor	1	The illustration means nothing without the text description.
Common Elements		This illustration had no deduction for common element misuse
Screenshot		
Type	2	Poor view, should be larger to envision 3-D effect.
Clarity	2	Unclear, too small to read.

The overall rating for the screenshot illustration averaged 1.9, slightly less than somewhat effective. In comparison, Figure 31 and Table 14 represent an example of an effective screenshot illustration, earning a 3.0 overall rating (image scan somewhat unclear).

sheet programs, such as Excel, have optimizing features (Figure 10.2). C-11, an appliance manufacturer, used an optimization program called *optimization-based decision support system (OBDSS)* to help it reduce the time and cost of manufacturing appliances.² The company estimated that profits increased more than \$3 million as a result of the OBDSS.

A **satisficing model** is one that will find a good—but not necessarily the best—problem solution. Satisficing is usually used because modeling the problem properly to get an optimal decision would be too difficult, complex, or costly. Satisficing normally does not look at all possible solutions but only at those likely to give good results. Consider a decision to select a location for a new plant. To find the optimal (best) location, you would have to consider all cities in the United States or the world. A satisficing approach would be to consider only five or ten cities that might satisfy the company's requirements. Limiting the options may not result in the best decision, but it will likely result in a good decision without spending the time and effort to investigate all cities. Satisficing is a good alternative modeling method because it is sometimes too expensive to analyze every alternative to get the best solution.

satisficing model
a model that will find a good—but not necessarily the best—problem solution

FIGURE 10.2
Some spreadsheet programs, such as Excel, have optimizing routines. This figure shows Solver, which can find an optimal solution given certain constraints.

Figure 31. Effective screenshot illustration

Table 14

Effective screenshot illustration results

General Guidelines	Rating	Rationale
Proximity	3	The illustration follows the text it is meant to clarify, without flipping the page.
Crowding	3	The illustration utilizes the proper amount of white space.
Label	3	There is a label and number identifying the illustration. No title necessary due to caption.
Audience	3	The level and context of the information matches the reader.
Interpret	3	The illustration is introduced by the text, and the readers are advised of what to expect.

Captions	3	Caption helps define illustration, and assist with stand-alone.
Confusion Factor	3	The illustration is uncluttered and easy to interpret.
Stand-alone Factor	3	Illustration and caption create a stand-alone figure.
Common Elements		No deduction for common element misuse
Screenshot		
Type	3	Screenshot displays Excel program in background, and optimizing routine for good clear context.
Clarity	3	Good resolution, easy to read.

Figure 32 and Table 15 represent a somewhat effective illustration from the graph category.

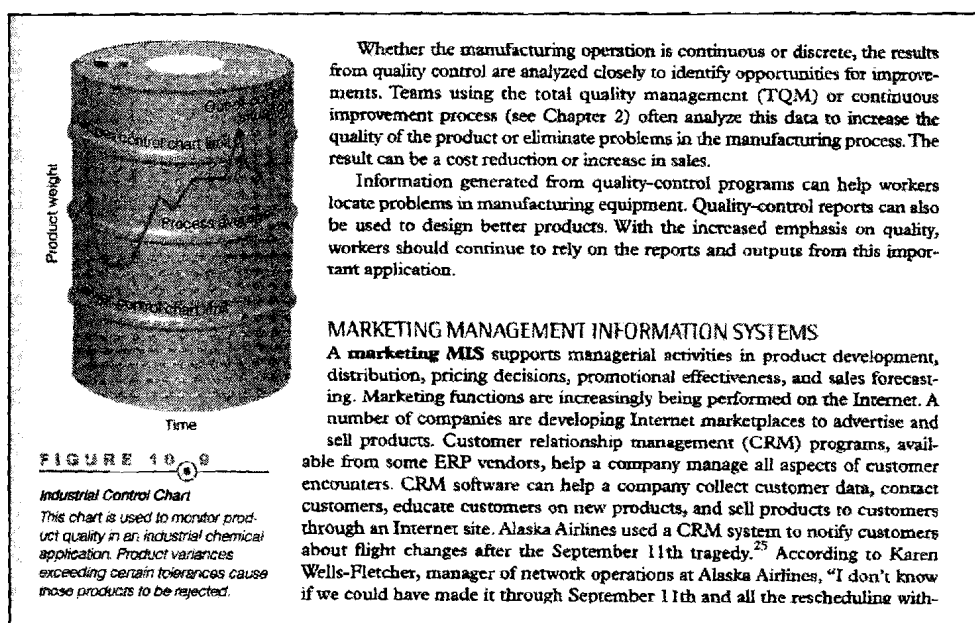

Figure 32. Somewhat effective graph illustration

Table 15

Somewhat effective graph illustration results

General Guidelines	Rating	Rationale
Proximity	3	The illustration follows the text it is meant to clarify, without

		flipping the page.
Crowding	2	The illustration utilizes the minimal amount of white space, and is placed in the margin.
Label	3	There is a title, label, and number identifying the illustration.
Audience	3	The level and context of the information matches the reader.
Interpret	2	The label and number properly introduce the illustration. However, the text describes multiple attributes, and the graph displays one.
Captions	3	The caption helps explain the chart.
Confusion Factor	2	The illustration is not cluttered, but is hard to interpret.
Stand-alone Factor	3	Illustration and caption create a stand-alone figure.
Common Elements		
Key or Legend	-.125	Deduction for lack of a key or legend to match text description of multiple attributes
Graph		
Distortion	3	No distortion.
Context	2	Limits encourage reader to compare weight averages, but text describes multiple attributes.
Chartjunk	1	Barrel is a distraction, does not match other graphs in textbook, and does not encourage readers to think about the substance of the graph statistics.
General	2	The curve of the line is evident. The x-y relationship is evident, but the labels are non-distinct.

The overall rating for the graph illustration averaged 2.29, slightly above somewhat effective. In comparison, Figure 33 and Table 16 represent an example of an effective graph illustration, earning a 3.0 overall rating.

The Class A and B addresses make up 75 percent of the IPv4 address space, but a relative handful of organizations (fewer than 17,000) can be assigned a Class A or B network number. Class C network addresses are far more numerous than Class A and B addresses, although they account for only 12.5 percent of the possible 4 billion IP addresses, as shown in Figure 7-10.

Figure 7-10 IP Address Allocation

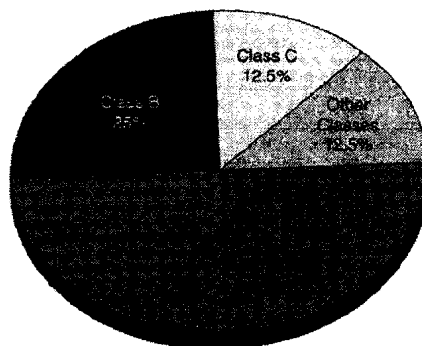

Figure 33. Effective graph

Table 16

Effective graph illustration results

General Guidelines	Rating	Rationale
Proximity	3	The illustration follows the text it is meant to clarify, without flipping the page.
Crowding	3	The illustration utilizes the proper amount of white space.
Label	3	There is a label, number, title identifying the illustration.
Audience	3	The level and context of the information matches the reader.
Interpret	3	The illustration is introduced by the text, and the readers are advised of what to expect.
Captions	3	No need for caption due to title.
Confusion Factor	3	The illustration is uncluttered and easy to interpret.
Stand-alone Factor	3	Illustration and title create a stand-alone figure.
Common Elements		No deduction for common element misuse
Graph		
Distortion	3	No distortion.

Context	3	Reader is encouraged to compare various classes of IP addresses.
Chartjunk	3	No use of chartjunk.
General	3	Size of pie pieces relevant to easy-to-read descriptions and percentage variables.

Figure 34 and Table 17 represent a somewhat effective illustration from the table category.

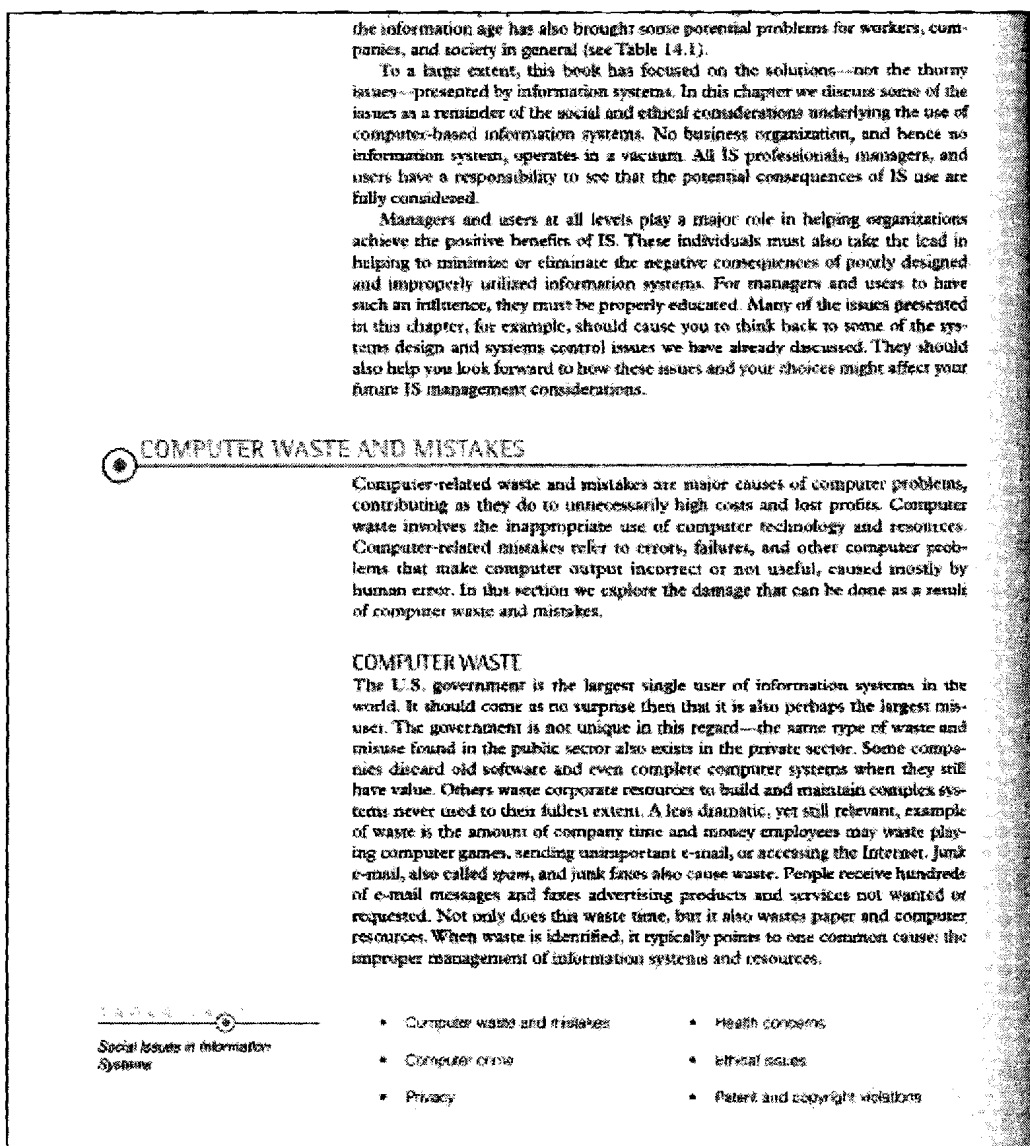

Figure 34. Somewhat effective table illustration

Table 17

Somewhat effective table illustration results

General Guidelines	Rating	Rationale
Proximity	2	The illustration follows the text it is meant to clarify, without flipping the page. However, the illustration is referred to early, before covering any of the topics in the table.
Crowding	2	The illustration utilizes a minimal amount of white space, and is crowded at the bottom of the page.
Label	3	There is a label and number, and title identifying the illustration.
Audience	3	The level and context of the information matches the reader.
Interpret	2	The label and number properly introduce the illustration. However, the text describes potential problems, where the illustration is titled social issues in information systems.
Captions	3	No need for caption.
Confusion Factor	2	The illustration is not cluttered, but is hard to interpret since the text calls for a table, but the illustration resembles a bulleted list.
Stand-alone Factor	3	Illustration and caption create a stand-alone figure.
Common Elements		No deduction for common element misuse.
Table		
Title	1	No title on table header (no header).
Format	1	No boxhead; column and body are combined

The overall rating for the table illustration averaged 2.2, slightly above somewhat effective. In comparison, Figure 35 and Table 18 represent an example of an effective table illustration, earning a 2.9 overall rating.

Because 3 bits can define eight values, 802.1p defines eight traffic classes. These traffic classes, and their associated traffic types, are listed in the 802.1p Traffic Classes Table.

802.1p Traffic Classes

Traffic Class (Priority)	Tag Value (Binary)	Traffic Types
7	111	Network control
6	110	Interactive voice
5	101	Interactive multimedia
4	100	Controlled load applications (streaming multimedia)
3	011	Excellent effort
2	010	Spare
1	001	Background
0	000	Best effort (default)

Figure 35. Effective table illustration

Table 18

Effective table illustration results

General Guidelines	Rating	Rationale
Proximity	3	The illustration follows the text it is meant to clarify, without flipping the page.
Crowding	3	The illustration utilizes the minimal amount of white space, and is placed in the margin.
Label	2	There is a title identifying the illustration, but no numbered label.
Audience	3	The level and context of the information matches the reader.
Interpret	3	The title properly introduces the illustration, and the text advises readers what to expect.
Captions	3	No need for caption.
Confusion Factor	3	The illustration is not cluttered, and easy to interpret.

Stand-alone Factor	3	Illustration and title create a stand-alone table.
Common Elements		No deduction for common element misuse.
Table		
Title	3	Typeface of title is smaller than surrounding text, brief and concise.
Format	3	The boxhead contains bold headings (with definitions); the columns properly define the information, and appear adjacent.

Figure 36 and Table 19 represent a somewhat effective illustration from the combination category.



	Inputs	Processing mechanisms	Outputs	Goal
	Coffee beans, his help, water, sugar, cream, spices, perfumes, other ingredients, labor, management.	Grinding, roasting.	Coffee, tea, pastries, other beverages and food items.	Quickly prepared, delicious coffee, tea, and various food items.
	Students, professors, administrators, textbooks, equipment.	Teaching, research, service.	Education, research, service to community, state, and nation.	Acquisition of knowledge.
	Actors, directors, staff, sets, equipment.	Filming, editing, postproduction, distribution.	Finished film, sold to video stores, theaters.	Entertaining movie, like awards, profits.

FIGURE 36
Examples of Systems and Their Goals and Elements
(Sources: © Steve Smith/Corbis, Courtesy of The Visual Systems Division, Image Copyright © 1999 PhotoDisc.)

feedback mechanism (your assessment of how clean the car is). Liquid sprayers shoot clear water, liquid soap, or car wax depending on where your car is in the process and which options you selected. The output is a clean car. It is important to note that independent elements or components of a system (the liquid sprayer, foaming brush, and air dryer) interact to create a clean car. Figure 1.4 shows a few systems with their elements and goals.

Figure 36. Somewhat effective combination illustration

Table 19

Somewhat effective combination illustration results

General Guidelines	Rating	Rationale
Proximity	2	The text describing and referring to the illustration follows the illustration.
Crowding	2	The illustration utilizes a good amount of white space, but is unnecessarily too large.
Label	3	There is a label and number, and title identifying the illustration.
Audience	2	The pictures in the illustration bring the figure to a level below that of the target audience with decorative images.
Interpret	2	The label and number introduce the illustration. However, the text description is brief.
Captions	3	No need for caption.
Confusion Factor	2	The illustration contains pictures cluttered together, but is somewhat easy to interpret.
Stand-alone Factor	3	Illustration and caption create a stand-alone figure.
Common Elements		No deduction for common element misuse.
Effectiveness Rating	2	In this case, combining decorative pictures with a table missing the title create a somewhat effective combination.

The overall rating for the illustration averaged 2.33, slightly above somewhat effective. In comparison, Figure 37 and Table 20 represent an example of an effective combination illustration, earning a 3.0 overall rating.

Router Operation at the Network Layer

Routers operate at the network layer by tracking and recording the different networks and choosing the best path to those networks. The routers place this information in a routing table, which includes the following items (see Figure 2-22):

- **Network addresses**—Represent known networks to the router. A network address is protocol-specific. If a router supports more than one protocol, it has a unique table for each protocol.
- **Interface**—Refers to the interface used by the router to reach a given network. This is the interface that forwards packets destined for the listed network.
- **Metric**—Refers to the cost or distance to the target network. This is a value that helps the router choose the best path to a given network. This metric changes depending on how the router chooses paths. Common metrics include the number of networks that must be crossed to get to a destination (also known as *hops*), the time it takes to cross all the interfaces to a given network (also known as *delay*), or a value associated with the speed of a link (also known as *bandwidth*).

Figure 2-22 Routing Tables

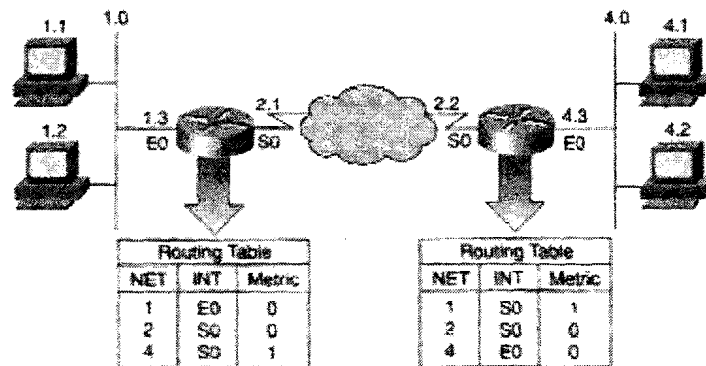

Figure 37. Effective combination illustration

Table 20

Effective combination illustration results

General Guidelines	Rating	Rationale
Proximity	3	The illustration follows the text it is meant to clarify, without flipping the page.
Crowding	3	The illustration utilizes the proper amount of white space.
Label	3	There is a title, label, and number identifying the illustration.
Audience	3	The level and context of the information matches the reader.
Interpret	3	The title properly introduces the illustration, and the text advises readers what to expect.

Captions	3	No need for caption.
Confusion Factor	3	The illustration is not cluttered, and easy to interpret given the text introduction.
Stand-alone Factor	3	Illustration and title create a stand-alone figure.
Common Elements		This illustration had no deduction for common element misuse.
Effectiveness Rating	3	Combining a diagram illustrating the relationship between the routers, and the use of routing tables create an effective combination.
