

A TRANSACTIVE ENERGY FRAMEWORK FOR MULTI-ENERGY MANAGEMENT IN  
SMART COMMUNITY

by

Jun Lei

A Thesis Submitted in  
Partial Fulfillment of the  
Requirements of the Degree of

Master of Science

in Engineering

at

The University of Wisconsin-Milwaukee

May 2019

## ABSTRACT

### A TRANSACTIVE ENERGY FRAMEWORK FOR MULTI-ENERGY MANAGEMENT IN SMART COMMUNITY

by

Jun Lei

The University of Wisconsin Milwaukee, 2019  
Under the Supervision of Professor Lingfeng Wang

Most community systems with large commercial buildings have heating, ventilation and air conditioning systems. In this case, EHs (energy hubs) can be formed in these communities in order to maximize the utilization of energy. The concept of energy hub was proposed to facilitate the synergies among different forms of energy carriers. Under the new electricity market environment, it is of great significance to build a win-win situation for prosumer and the hub manager at the community level without bringing extra burden to the utility grid. A set of economic and control mechanisms that allows the dynamic balance of supply and demand across the entire electrical infrastructure using value as a key operational parameter. With the increasing penetration of distributed generators and flexible loads in our communities, they are also bringing great intermittency and stochasticity to the power grid. It is very important to maintain the balance between the energy resources and loads to maximize the social welfare. To address the negative impacts of intermittent renewable energy sources, a bilevel programming method to make a day-ahead optimization has been proposed in this thesis. For the upper layer, hub manager seeks ways to minimize their transactive cost of buying electricity and gas from the utility to satisfy load demand, it gives buying prices of electricity and heat of load after optimization to every prosumer in this

energy hub. On the other hand, the prosumer using the given prices to do the optimized dispatch of their own then get their outputs in each hour while keeping the profits maximized. Ultimately, the optimized prices of this community are formed. We use Karush–Kuhn–Tucker (KKT) condition to transfer the proposed problem into a mixed integer linear problem, and it is solved by MATLAB software with intlinprog solver. The results validate the effectiveness and feasibility of this solution.

© Copyright by Jun Lei, 2019

All Rights Reserved

To  
my parents,  
my teachers,  
and my friends who give me love

## TABLE OF CONTENTS

LIST OF FIGURES.....	viii
LIST OF TABLES.....	x
LIST OF ABBREVIATIONS.....	xi
ACKNOWLEDGEMENTS.....	xii
Chapter 1 Introduction of the Dispatch of EH.....	1
1.1 Introduction of EH.....	1
1.2 Background of the Dispatch of EH.....	1
1.3 Review on the Methods of Dispatch of EH.....	3
Chapter 2 Transactive Energy.....	5
2.1 The Concept of TE.....	5
2.2 Differences between TE and traditional grid.....	7
2.3 The importance of TE.....	8
2.4 Review of Using TE Concept.....	9
Chapter 3 Combination of the EH and TE.....	11
3.1 Measures to boost the development of smart cities with smart energy construction...11	
3.2 Specific application of smart energy construction projects.....13	
3.2.1 the Development of New Energy Vehicles.....14	
3.2.2 Utilization of clean energy.....16	
3.2.3 Urban Heating Reconstruction.....19	
3.2.4 Demand Side Response Management.....20	
Chapter 4 Structure of Trading Model.....	22
4.1 The Structure of EH.....	22
4.2 Interactive Model for the Community.....	23
4.3 Components in Community.....	24
4.3.1 Combine Heat and Power.....	24
4.3.2 Gas Boiler System.....	25
4.3.3 Electricity Storage System.....	27
4.3.4 PV.....	29
4.4 Optimization Model of the Whole EH.....	29

4.4.1	Objective function of Optimization of Bilevel Model.....	31
Chapter 5	Case Study.....	33
5.1	Basic Data.....	33
5.2	Optimization Dispatch .....	35
5.2.1	ESS .....	40
5.2.2	CHP .....	41
5.2.3	GB.....	42
5.3	Optimization Dispatch with Transactive Energy.....	43
5.3.1	Karush–Kuhn–Tucker (KKT) conditions .....	44
5.3.2	Big M Method.....	48
5.3.3	Optimization of the EH with TE.....	48
5.3.4	Optimization Results.....	50
5.4	Comparative Analysis.....	53
Chapter 6	Conclusion and Future work .....	57
6.1	Conclusion .....	57
6.2	Future Work.....	57
REFERENCES	.....	59

## LIST OF FIGURES

- Figure 1. Transactive Energy System
- Figure 2. Transactive Network
- Figure 3. The Structure of the EH
- Figure 4. Interactive Diagram of Community
- Figure 5. Energy Conversion Diagram of CHP
- Figure 6. The System Structure of GB
- Figure 7. The System Structure of ESS
- Figure 8. The Interaction Scheme Between Upper Layer and Lower Layer
- Figure 9. Total power curves of all prosumers in a typical day
- Figure 10. The electricity generated by PV
- Figure 11. The Electricity Prices of the Utility
- Figure 12. The Outputs of Electricity of the EH
- Figure 13. the Outputs of Heat in the EH
- Figure 14. Status of Charge level of ESS
- Figure 15. the Operation of ESS in the 24 hours
- Figure 16. the Output of the CHP
- Figure 17. the relation between the output of the CHP and the GB
- Figure 18. the Electricity Output of the EH With TE
- Figure 19. the heating output of the EH with TE
- Figure 20. the state of charge level of the EH with TE

Figure 21. the output of the HSS with TE

Figure 22. the output of the CHP with TE

Figure 23. the output of the GB with TE

## LIST OF TABLES

Table 1. Differences Between Traditional Grid and Smart Grid

Table 2. The Related Parameters

Table 3. the Optimization Objective Functions of Two Methods

Table 4. the Total Costs of the Whole EH

## LIST OF ABBREVIATIONS

EH	Energy Hub
CHP	Combined Heat and Power
MCES	Multi-carrier energy system
MPEC	Mathematical Program with Equilibrium Constraints
RESs	Renewable Energy Resources
DERs	Distributed Energy Resources
ESS	Electricity Storage Systems
TE	Transactive Energy
SG	Smart Grid
GB	Gas Boiler
HM	Hub Manager
ISO	Independent System Operator
PV	Photovoltaic
EU	Electricity of the Utility
SOC	State of Charge Level
BSPP	Bilevel Sophisticated Programming Problem
KKT	Karush–Kuhn–Tucker
DSM	Demand Side Management

## ACKNOWLEDGEMENTS

First of all, I want to thank my advisor, Professor Lingfeng Wang, for selecting this compelling theme as my thesis topic and for his patient guidance. In the course of my research at UW-Milwaukee, Prof. Wang gave me a lot of valuable comments and suggestions.

The successful completion of this thesis is also due to the help from the big family of our laboratory, especially Dr. Zhaoxi Liu and Dr. Li Ma. I would not have completed this thesis without their timely help. They indeed gave me great help in research.

I also want to thank my neighbors for their warm care, makes me feel a big family which is far away from home.

Thanks go to Professor Chiu Tai Law and Professor Guangwu Xu for their time and effort in serving on my defense committee.

I am also grateful for the financial support for this research. This work was supported in part by the National Science Foundation Industry/University Cooperative Research Center on Grid-connected Advanced Power Electronic Systems (GRAPES) under Awards GR-17-14 and GR-18-02.

Last but not least, tremendous thanks go to my parents, for giving me a chance to study here. It is truly a fantastic and unforgettable experience in my life. Thank them for their support throughout years. I also want to thank my boyfriend for his kind comfort, care and understanding.

Thank you all for what you have done to help me throughout this journey.

# Chapter 1 Introduction of the Dispatch of EH

As an important place for human activities, cities consume a large amount of materials and energy. It is of great significance to realize the low-carbon and sustainable development of cities in promoting energy conservation, emission reduction and environmental protection. At present, the EU mainly promotes the low-carbon transformation of cities by promoting renewable energy, adjusting energy prices, improving the quality of building materials and reducing consumption. In this case, as a combination of electricity and heat, EH can have significant influence on the purpose of energy conservation, storage and environment protection.

## 1.1 Introduction of EH

Energy hub are centralized units which have transformation conversion and storage of various forms of energy [1]. Within the hub, energy is converted and conditioned using, for example, combined heat and power technology, transformers, power-electronic devices, compressors, heat exchangers and other equipment. Combining means to couple them, thereby enabling exchange of power among them. Couplings are established by converter devices that can transform power into other forms [2]-[3]. An EH can supply multiple energy loads by importing multi-types of energy.

## 1.2 Background of the Dispatch of EH

Industrial, commercial and residential consumers require various forms of energy services provided by different infrastructures. Combining systems can result in a number of benefits.

Synergy effects among various energy carriers can be achieved by taking advantage of their specific virtues.

There are two significant benefits using EH in our communities: [1]

- 1) Reliability of supply can be increased from the load's perspective because it is no longer fully dependent on a single network. Alternatively, reliability of the individual infrastructures could be reduced, like by reducing maintenance, while availability for the load remains high.
- 2) The additional degree of freedom enables optimization of the supply of the hub. Energy carriers offered at the hub's input can be characterized based on their cost, related availability and other criteria, then the inputs can be optimally dispatched based on these quantities. In addition, utilizing energy storage represents an opportunity for increasing the overall system performance, therefore, storage is already taken into account in the planning phase. Especially when energy sources with intermittent primary energy are considered, storage becomes important since it enabled affecting the corresponding power flows.

[4] discusses the operation mode and evaluation index of the co-supply system after the addition of solar power generation and solar collector and designs the corresponding control strategy and operation optimization method, but only considers the clean energy of solar energy. The mathematical model of peak load regulation and storage optimization for CHP system with PV and energy storage is established in [5].

### 1.3 Review on the Methods of Dispatch of EH

In recent years, energy systems structures have appreciably evolved with rapid developments and wide applications of energy conversion technologies to cope with potential energy crises [6].

The influence of solar energy and energy storage mode on energy cost is deeply explored on the basis of the existing energy hub in [7], but the objective function does not consider the energy and environment.

Taking the energy Internet as the background, [8] mainly studies the equivalent conversion relationship and its benefit model between different "energy and mass" energies in the conversion and utilization process of a variety of energies, various objectives such as energy efficiency and cost is taken into account, and optimizing them with particle swarm optimization algorithm, but not considering the conversion of heat and electricity.

With the present of energy Internet, multi-energy complementarity has become an inevitable promising trend, and the progress of distributed energy technology has also promoted the development of energy network

As the widespread utilization of highly efficient energy conversion facilities like combined heat and power (CHP) units grows, independent energy systems become more tightly coupled [9]. The co-optimization is essential to a multi-carrier energy system (MCES) for improving the energy efficiency and maintaining the sustainability and the reliability of energy infrastructures [10-11].

Considerable research work has been done with respect to the optimal planning and operation of MCES. For example, the expansion planning of combined electricity and natural

gas systems is studied in [12] and [13]; the energy hub concept is proposed in [14] and the optimal energy flow of multiple energy carriers is formulated in [15] and [16]; the operation strategy of a multi-energy system is discussed in [17]-[22]; the residential energy hubs and delivery systems have been studied in [23]-[31].

In [32], a comprehensive model for the EH's self-scheduling is proposed to supply building heating and electrical demands. An optimization framework based on a hybrid scenario-based/interval/information gas decision theory method is presented in [33] for the optimal operation of EH considering the uncertainties of price, load and renewable generation. In [34], the optimal EH participation in electricity and heat distribution markets is investigated, where a mathematical program with equilibrium constraints (MPEC) model is proposed to study the strategic behavior of a profit-driven energy hub in an integrated energy market.

In this thesis, a comprehensive optimization model for a MERS is proposed considering the characteristics of electric power and natural gas distribution networks, renewable energy resources (RESs), residential appliances, and distributed energy resources (DERs) including electricity storage systems (ESSs), and combined heat and power (CHP) units. A sophisticated bilevel decision-making framework is proposed for an EH operator to minimize its cost by buying electricity and heat, where the upper level minimizes the EH cost and the lower level maximize energy user's profits.

## Chapter 2 Transactive Energy

### 2.1 The Concept of TE

Transactive energy (TE) is a relatively new concept, on its way to becoming ubiquitous in industry blogs, and is associated with notions such as the “internet of things”, “eBay of electricity”, and “democratization of electricity”. Some define it as “an internet-enabled free market, where customer devices and grid systems can barter over the proper way to solve their mutual problems, and settle on the proper prices for their services, in close to real time” [35]. It is described as a cool and trendy approach and some pundits perceive it as a concept that “may help all of us avoid a very dark future” [35]. Some call it a revolution and others call it an evolution. It is also advertised as a sustainable business and regulatory model for electricity. Some experts perceive it as just a Smart Grid (SG) application while others argue that the grid is not smart unless it is transactive.

So the concept of TE become an important task. Is it a new hype in the electricity world, or is it a potential solution for the problems the power grid is facing today? The GridWise Architecture Council’s Framework defines TE as follows:

“A set of economic and control mechanisms that allows the dynamic balance of supply and demand across the entire electrical infrastructure using value as a key operational parameter” [36].

Accordingly, TE is a vision of an intelligent device-enabled-grid where each device can utilize economic signals in order to optimize allocation of resources subject to the constraints of the grid. It can be applied within a localized area, like microgrid, or be utilized to manage the whole power system. A visual description of the contemplated TE system is as follows:

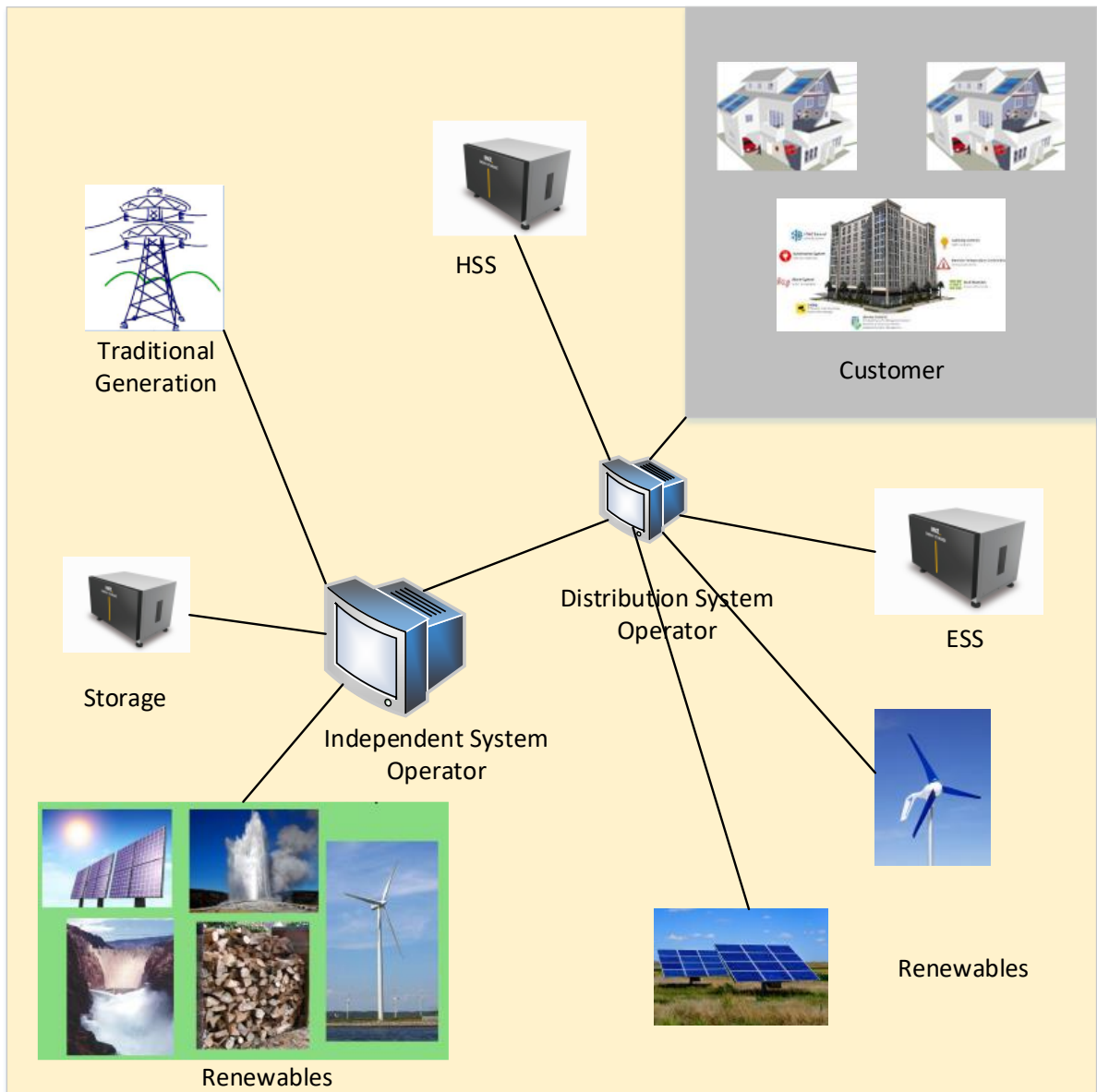

Fig. 1. Transactive Energy System

As illustrated in the picture above, customers of all sizes get connected and can buy and/or sell, if they choose to do so, in a network environment, rather than on a hierarchical grid. Free communication of information between parties allows them to enter into exchanges. Taking it one step further, some TE visionaries simplify the picture even further by operationalizing it through the use of a market exchange platform, where all parties are networked through it. This operationalization reflects four ideas of the TE world:

1. There are two products: energy and transport services;

2. Forward transactions are used to manage risk and coordinate investment decisions;
3. Spot transactions are used to coordinate operating decisions;
4. All parties act autonomously.

## 2.2 Differences between TE and traditional grid

Firstly, I would like to discuss the differences between a traditional grid and smart grid

[37]:

Table. 1. Differences Between Traditional Grid and Smart Grid

Existing Grid	Smart Grid
Electromechanical	Digital
One-way communication	Two-way communication
Centralized generation	Distributed generation
Few sensors	Sensors throughout
Manual monitoring	Self-monitoring
Manual restoration	Self-healing
Failures and blackouts	Adaptive and islanding
Limited control	Pervasive control
Few customer choices	Many customer choices

Then after we find the differences between TE and SG, we can easily get the benefits of TE from traditional grid. There are additional characteristics that make SG transactive:

1. Allowing for the faster transmission of information, including prices, across the grid, through communication component of the smart grid;

2. Empowering consumers by enabling consumers' active participation;
3. Accommodating all new generation devices needed for a functional decentralized supply model;
4. Accommodating two-way power flows.

## 2.3 The importance of TE

Transaction networks and agent-based systems present an opportunity to implement strategies in which highly “optimized” control (both local and global) is an inherent attribute of the strategy rather than an explicitly programmed feature. The premise of transaction-based control is that interactions between various components in a complex energy system can be controlled by negotiating immediate and contingent contracts on a regular basis in lieu of or in addition to the conventional command and control.

Expanding the electricity market into the retail domain calls for inexpensive mass-produced smart devices that enable the small customers to participate in local energy transactions by managing the energy production/consumption and submitting buy/sell bids to the market. Each device is given the ability to negotiate deals with its peers, suppliers and customers to maximize revenues while minimizing costs [38].

Adding TE into the community area makes it more secure, clean and efficient [39]. It ensures the accuracy of the feedback from the system because of the decentralized management, because it not only gets information from the central manager only. It becomes less sensitive about the impact of the happening issues.

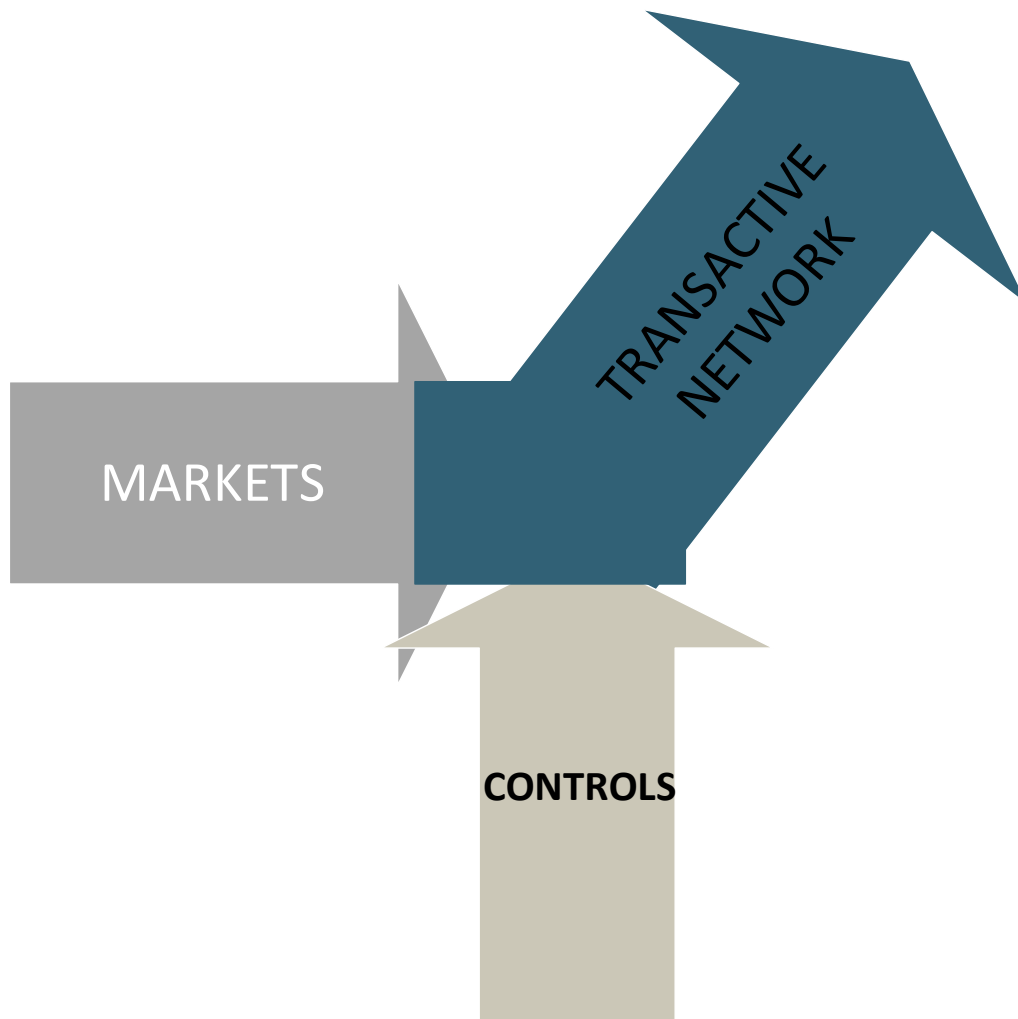

Fig. 2. Transactive Network

## 2.4 Review of Using TE Concept

A decentralized approach has been proposed using the privacy of residential consumers as the ‘value’ to minimize the cost in [40]. A quota-based energy storage charging and discharging strategy is added into the model which is in response to dynamical pricing variations of the electricity in [41]. Then a two directional transaction model is presented in [42], where each household in the system can sell extra energy after satisfying non-shiftable loads back to the grid, the output of the system is influenced by the reaction of the load to the price of electricity.

In [43], a comparative study is proposed within centralized, decentralized and distributed approaches. A centralized and distributed approach of exchanging intermittent energy among different houses in a local community is presented in [44], it has been tested in both hardware and software platforms.

In this thesis, we combined all the features of the above literature, we built a model with two directional dynamic transaction in a decentralized system with distributed energy. We set the signal of the prices of electricity and heat as the 'value'. The problem of energy management in the EH within a community area has been addressed extensively using a bilevel model. The TE idea is added into this model as the price signal given to the prosumers and load in the EH for doing the optimization to maximize their profits. By responding to a form of pricing information from the HM, the HM could get the proper price to load while minimize the cost of buying energy from the utility.

## Chapter 3 Combination of the EH and TE

### 3.1 Measures to boost the development of smart cities with smart energy construction

To develop smart energy to boost the development of smart cities, we must increase the absorption and utilization of renewable and clean energy. Effective use of renewable energy is an important way to build low-carbon cities. The carrier of smart energy is renewable energy. To develop smart energy, we must popularize renewable energy, especially solar energy and wind energy. By developing the smart energy, we can promote the development of green energy, transform the urban energy structure, and achieve the transformation of the urban energy structure from fossil energy to green energy.

Developing smart energy to power smart cities is the trend. Vigorously developing electric vehicles has been promoted as a national energy strategy. The fundamental purpose of low-carbon city transportation construction is to reduce carbon emissions. By promoting electric cars, the city will reduce the carbon emissions of transportation tools used by enterprises and individuals, so as to achieve the goal of reducing the carbon emissions of the whole city.

In the context of slow upgrading of battery technology, we can consider making breakthroughs in improving supporting facilities such as dry charging stations and charging stations to drive the real rise of the new energy vehicle market. In the case of not increasing the land supply area, effectively avoid from the technical point of view, so as to solve the problem of charging.

To develop smart energy to boost the development of smart cities, more efforts should be made to reduce energy consumption during construction and daily high-speed operation of

buildings. A key component of low-carbon cities is green buildings. Green buildings should not only provide healthy, comfortable and efficient working and living space for people, but also save resources, protect the environment and reduce pollution to the greatest extent.

In the process of reducing carbon emission, it is of great significance to promote green building.

To develop smart energy to boost the development of smart cities, we need to encourage urban businesses to save energy, reduce emissions and reuse waste energy. In the development planning of low-carbon cities, in order to achieve energy conservation, reduce carbon emissions, to achieve low carbon industry, carbon emissions of various industries should be reduced, backward and highly polluting processes and equipment should be eliminated, and we should support the use of advanced, efficient and clean processes and equipment, promote the replacement of electric energy by industrial and commercial enterprises and the reuse of waste energy.

To develop smart energy to facilitate the development of smart cities, efforts should be made to integrate independent and decentralized information platforms to form a comprehensive energy service platform. The integrated energy service platform will improve the process architecture system of traditional energy, and further build the overall architecture of the utilization, development and consumption of new energy, and become a more efficient intelligent configuration and intelligent exchange in various energy network architectures, thus promoting the accelerated and healthy development of low-carbon cities.

To develop smart energy and promote the development of smart cities, it is necessary to construct the flattening system of energy organization through top-level design.

The flattening of the energy organization can promote the benign and sustainable construction of low-carbon cities by stimulating scientific and technological innovation, optimizing industrial structure, promoting energy conservation, and promoting multi-party cooperation.

To vigorously promote the construction of smart energy cities, we need to think about how to break the limitations of low-carbon urban development, we can start with the innovation of the energy system, the healthy development of energy technologies, the development and utilization of new energy sources, the substantial reduction of energy consumption and the steady supply of energy.

By formulating advanced systems, creating appropriate energy policies and designing reasonable energy rules, smart energy reform can improve social production relations and provide effective guarantee for rapid economic and social development. Therefore, the great development of smart energy in cities will be the focus of urban development in the future and the key means to comprehensively enhance the competitiveness of cities.

### 3.2 Specific application of smart energy construction projects

Smart energy construction covers the whole process of energy development, energy utilization, energy production, energy consumption and energy recovery, and establishes a new energy system that meets the requirements of sustainable development.

Smart energy construction means the mature application of traditional energy improvement technology and new energy replacement technology. With the crossover and progress of these two energy technologies, energy consumption will be reduced, pollution will be reduced or

even eliminated, and energy supply will be more systematic, safe, clean and economic. At the same time, smart energy means the innovation and reform of the system, which is conducive to integrating resources and energy, improving the input-output ratio, and reducing the negative impact on the environment and ecology.

By changing traditional ideas about energy development and consumption, on the premise of the sustainability of the ecological environment, taking the sustainable development of economy and society as the goal, applying advanced new technologies and equipment to vigorously develop clean energy, we can establish a scientific and rational mode of energy production and consumption. Thus, alleviates the energy bottleneck restriction and the ecological environment pressure, promotes the economical society the harmonious development.

The following shows the application of smart energy construction by the development of new energy vehicles, utilization of clean energy, urban heating renovation, and power demand management.

### 3.2.1 the Development of New Energy Vehicles

Infrastructure is the foundation of the development of electric vehicles. The insufficient infrastructure construction, especially the lack of charging stations and charging piles, seriously restricts the practicality and convenience of electric vehicles.

In order to develop new energy vehicles on a large scale, the construction of charging facilities must take the first step. This is not only the consensus of developing new energy vehicles, but also the new idea of developing new energy vehicles.

1) Improve the policy system.

We need to accelerate the promotion and application of new energy vehicles, gradually ease the pressure on energy and the environment, and promote the upgrading and transformation of the auto industry.

2) Establishing new charging facilities.

In the case that the battery technology cannot be upgraded, it can be considered to seek breakthroughs in improving supporting facilities such as dry charging stations and charging stations, so as to drive the real rise of the new energy vehicle market.

Then let us discuss about the solutions. Based on the above ideas, the thesis puts forward the construction scheme of Internet plus charge try to solve the bottleneck of the development of new energy vehicles. Mainly to provide self-service slow charging service, which is controlled by mobile client APP. It supports remote charging reservation, self-charging, mobile phone payment and other functions.

This system management software is mainly composed of PC client, mobile client and data center. The data center includes mobile phone background service program, data sending and receiving service program and database. The software is sent to the client in the form of cd-rom. After the client installs the system, the target company will give the client an account and password, and the user can realize remote operation control and monitoring where there is a network.

PC client is usually used for the daily management of the main control center, the large screen of the main control center and the PC of the administrator operation desk need to install this software, which is used for the centralized lighting control of the whole system.

The mobile client is used for status query, temporary time scheme setting and daily maintenance, which can achieve 24-hour quick response.

Data is also the basis of the system, but also the core of the normal operation of the whole system, assume the data receiving, sending, storage and other important functions.

### 3.2.2 Utilization of clean energy

#### 1) Analysis of the situation

Excessive use of energy resources and ecological environment in the past has resulted in the current environmental carrying capacity has reached or close to the upper limit. Clean energy is the important fulcrum of the energy structure adjustment and even the whole economic structure adjustment.

Clean energy is sustainable energy, such as water energy, wind energy, solar energy, biomass energy and Marine energy.

Solar photovoltaic power generation is the main form of solar power generation, is a relatively mature technology, it has the advantages of safety and reliability, no noise, no pollution, energy can be obtained anywhere, no regional restrictions, no need to consume fuel, low failure rate of equipment, simple maintenance, low labor cost, unattended, short construction cycle, large or small scale range, and no need to set up transmission lines.

Ground power stations have various constraints, while distributed photovoltaic power generation makes full use of the widespread existence of solar energy, and avoids the site constraints of centralized construction, so it has the characteristics of flexible construction. Distributed photovoltaic power generation can be combined with buildings for comprehensive

utilization, effectively utilizing idle building roofs without occupying valuable land resources, which is more important for cities with a shortage of land resources. In addition, solar cell modules are usually installed on the roof, which can directly absorb the solar energy.

Distributed photovoltaic power generation system realizes in-situ power generation and in-situ utilization, which reduces the consumption of lines in the process of power transmission. Moreover, the solar cell modules are usually installed on the roof, which can directly absorb the solar energy, so the distributed photovoltaic system can reduce the temperature rise of the roof while generating electricity. The air-conditioning load of the building becomes smaller, and the energy consumption of the enterprise is also reduced, further reducing the operating cost of the enterprise. The above analysis is used to put forward the idea of roof construction of distributed photovoltaic:

The roof construction of distributed photovoltaic power generation system does not occupy an area alone, and the solar cell is installed on the existing roof, which is skillfully combined with the characteristics of low solar energy density, and its flexibility and economy are more advantageous than large ground power plants connected to the grid, which is conducive to better popularization. Roof building distributed photovoltaic integration has the characteristics of multi-function and sustainable development.

Integrated design makes the building cleaner, more perfect, more pleasing to the eye, and more easily accepted by professional architects, users and the public. The perfect combination of solar photovoltaic system and building embodies the ideal example of sustainable development.

## 2) Solutions

Rooftop PV construction mainly uses the space on the top of buildings to install solar cell modules on the roof and convert light energy into electric energy for electrical appliances.

Rooftop photovoltaic power stations are relatively small, from a few hundred watts to a few hundred kilowatts. They do not need to occupy a lot of land, while the scale of centralized large-scale power stations reaches the megawatt level. Rooftop photovoltaic power stations deliver power over short distances, rather than long distances, high or ultra-high voltage, as concentrated power stations do. Therefore, for urban and surrounding users, roof PV can bear and benefit by itself. If connected to the grid, it can also sell electricity to power grid companies to increase residents' income.

Roof photovoltaic grid-connected power generation is to convert solar energy into direct current energy by photovoltaic array, which is connected to the inverter through the junction box, and then connected to the power grid after the inverter inverts the direct current into alternating current.

The main components of roof PV construction are: solar cell modules and their supports, photovoltaic array lightning protection junction box, DC lightning protection distribution cabinet, PV grid-connected inverter, the communication monitoring device of the system, lightning protection and grounding devices of the system, distribution room and other infrastructure, system connection cable and protective material.

From the perspective of architecture, technology and economy, roof PV construction has many advantages:

- (1) The roof and wall of the building can be combined for efficient use, saving the occupied land resources. For the city with less land resources, it is more important to use the roof

of the building.

- (2) After the rooftop photovoltaic power generation, it can be used for its own buildings, reaching the "ready to use", which saves the investment of power station transmission network to a certain extent and scope. For the rooftop photovoltaic grid-connected system, after the rooftop photovoltaic power generation, it can not only supply its own building load, but also send the power to the grid to generate income;
- (3) In the daytime when the sun shines, rooftop PV is used for power generation. Generally speaking, the daytime in the city is the peak period of power consumption of the power grid, which can reduce the power supply pressure of the power grid and alleviate the peak power demand of the power grid.
- (4) Solar PV modules are installed on the south facade of the building's roof or wall to absorb solar energy. In this way, direct sunlight from the wall and roof can be avoided to achieve cooling effect.
- (5) After the construction of the roof photovoltaic system, there will be no noise, no pollutant emissions, no fuel consumption and other advantages, it is both green and environmental protection.

### 3.2.3 Urban Heating Reconstruction

#### 1) Analysis of the situation

Energy saving and emission reduction is a comprehensive problem. Energy use subsystem is a comprehensive system that influences and contains each other. If we only pursue the energy saving of one subsystem unilaterally, another subsystem may consume more energy, and the

final result may be that the total energy consumption will increase instead of decrease.

Therefore, energy conservation and emission reduction must use the view of system science, stand on a certain height, put forward the overall energy saving optimization solution is the most fundamental solution and solution ideas.

#### 1) Solutions

The heat supply system of regenerative electric boiler is adopted. During the off-peak period of power grid, electricity is used as energy to heat the heat storage medium and store it in the heat storage device and release the heat from the regenerator during peak periods to meet heating needs.

The heat storage medium of the regenerative electric boiler heating system is high-temperature water or normally wet water. In other words, when water is heated to a certain temperature, heat energy is stored in the water in the form of sensible heat. When heat is needed, its heat energy is released for heating. The system consists of electric boiler, high temperature water storage tank, plate heat exchanger and water pump.

### 3.2.4 Demand Side Response Management

#### 1) Analysis of the situation

With the sustained and rapid economic development, the growth rate of electricity demand is far greater than the growth rate of power supply, and the power gap in the process of social and economic operation has become one of the key issues affecting social and economic life.

The idea of demand side response management (DSM) was put forward by Con Edison in New York in 2011 at the beginning. It was used in a project which install controllers on the air-

conditioning system in some specific users' home, so that the users can turn on and off the air conditioner by remote control on app with their mobile phone.

Moreover, Con Edison would send a request to all participating users on the hottest days which are the energy peak days to turn off their air conditioners to reduce peak power consumption.

For the users who accept the request that asking them to turn off the air conditioner of their home, they will earn some cash reward which is set initially.

Power demand side response (DSM) refers to the market participation behavior of power users to consciously and voluntarily adjust the load of their electrical equipment to meet the reliability of power system, dynamic optimization and balance, and systematic energy saving and emission reduction in response to price signals or incentive mechanism when there are risks powering consumption during peak hours or system safety and reliability. For power users, the response measures should be more conscious and friendlier.

We do not apply this analysis in this article, but it is still a valuable topic.

# Chapter 4 Structure of Trading Model

## 4.1 The Structure of EH

The system architecture of the EH in this thesis is shown in Fig.3. There are two kinds of inputs: electricity and natural gas.

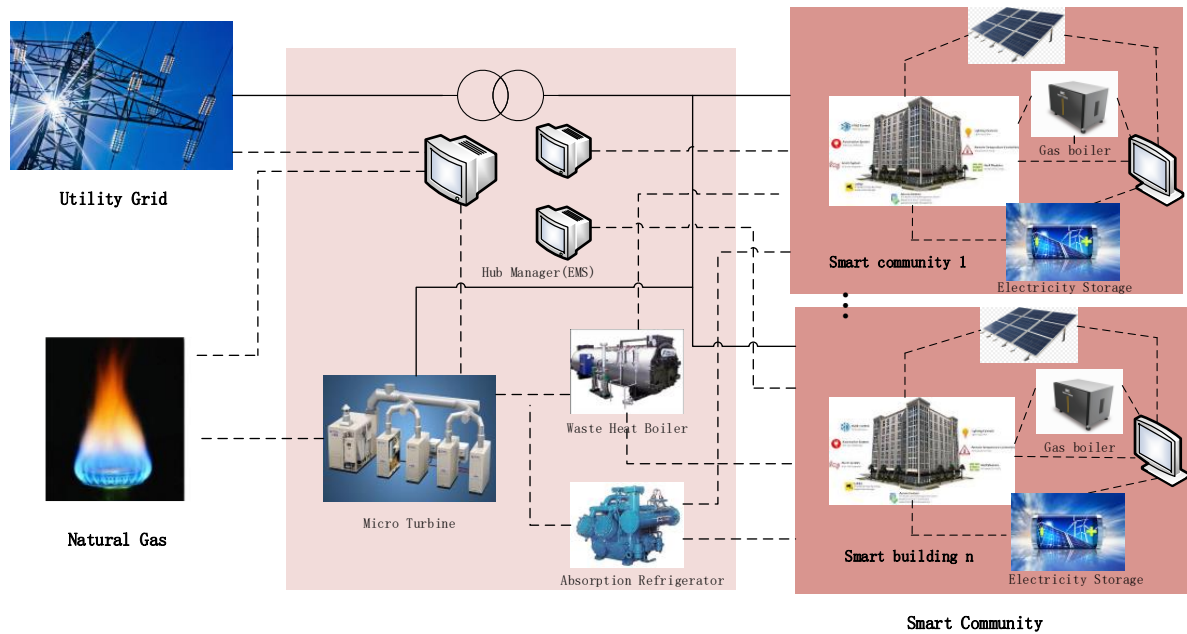

Fig. 3. The Structure of the EH

The EH consists of a Hub Manager (HM), a CHP system composed of microturbines, waste heat boilers, and absorption refrigerators. As we can see from the structure picture above, the EH is responsible for supplying several kinds of energies to the connected prosumers and the energy balance of EH. In the residential energy hub under study, the received electricity at input ports of the hub which is the combination of the utility electricity and the output of the PV is divided into three paths, one path to the demand directly, the second one to the ESS. As to heat sources of the EH, there are Gas Boiler (GB) and the CHP. They all consume gas to generate energy.

In this smart community, EH is also in charge of the interoperability among all participants,

in this transactive network, Hub manager working just like independent system operator (ISO). It can be seen as the energy management executor of the EH.

Each community consists of photovoltaic generator (PV), electricity storage system (ESS), Gas Boiler, CHP. As illustrated in Fig.3, the electricity demand can be charged by the utility, CHP, PV and ESS. ESS has capability to store energy from the utility and return the stored energy to the hub to supply electrical appliances when needed. On the other hand, the heat demand can be fulfilled by CHP and GB, they can shift its time of storage to make its profit maximized. Last but not the least, the heat output of CHP has great influences on the output of electricity of CHP at the meantime, vice versa.

HM is employed to gather data of the PV source, electric load, and thermal load, as well as to receive information from components inside the EH. In addition, the HM is in charge of controlling and optimizing the prosumers' energy consumption, then give optimized prices of energy products from the loads to ESS, GB and CHP, they give optimized outputs to the HM after their optimization in order to get the maximized profits.

## 4.2 Interactive Model for the Community

As we mentioned before, we apply an interactive model from a cooperative perspective in our EH in this thesis. The schematic diagram of the cooperative trading mode for this community is shown in Fig.4.

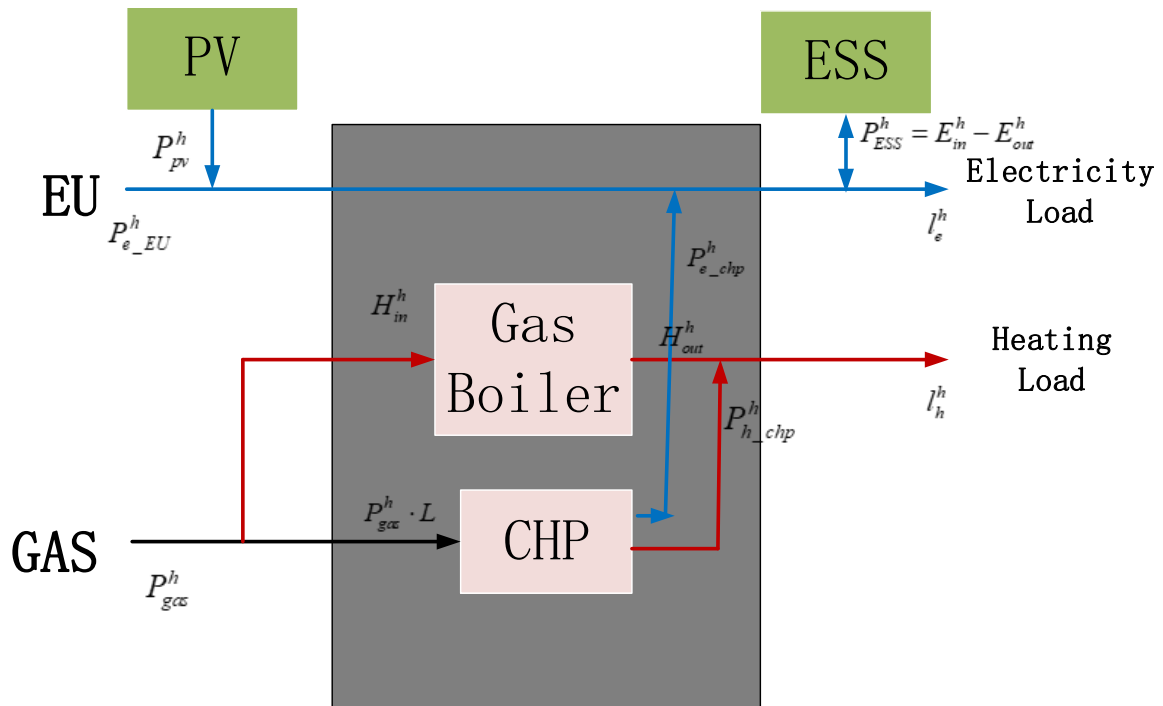

Fig.4. Interactive Diagram of the Community

### 4.3 Components in Community

#### 4.3.1 Combine Heat and Power

The structure of CHP is shown in the picture below.

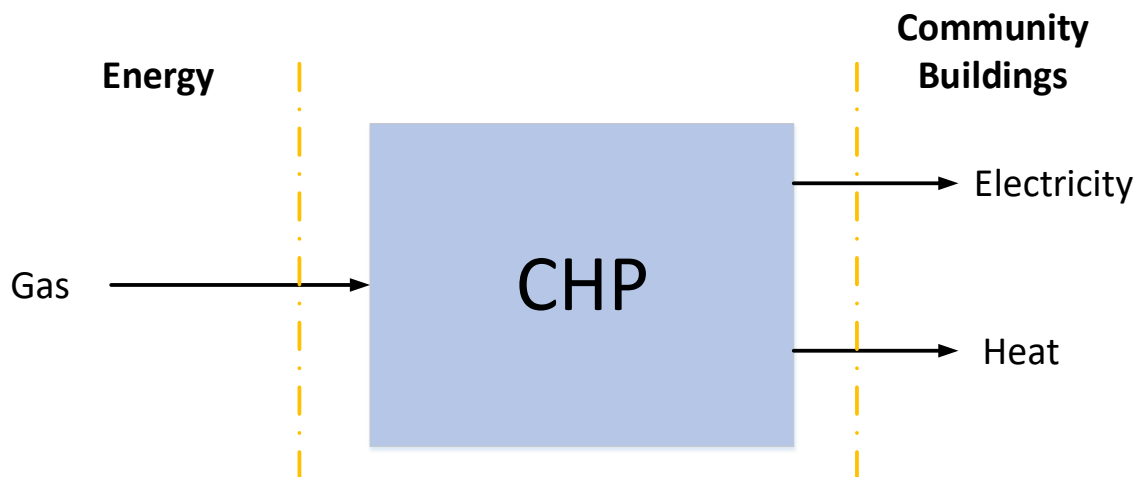

Fig.5. Energy Conversion Diagram of CHP

As we can see from fig.5, CHP absorb gas from the utility, there is a gas boiler in CHP turning natural energy into heat, then CHP transform part of heat into electricity. The model of the CHP system output consists of two parts, i.e., electricity and heat, and they have tight

connections to each other. The feasible region for a micro-turbine can be specified with a linear equation and two extreme points at the minimum and maximum power productions according to [45]. Then  $P_{e\_chp}^t$  can be determined according to the strategy of following the thermal load [46] - it is usually applied from the industry point of view by the following relationship:

$$P_{e\_chp}^t = \left( \frac{\sum_{i=1}^n l_{hi}^t}{\delta_{heat}} \right) * \frac{\eta_{chp}}{1 - \eta_{chp} - \eta_{loss}} \quad (4 - 1)$$

The cost of the CHP system can be defined as  $C_G$  [47]:

$$C_G = \left( \frac{k_G}{L} \right) * \left( \frac{P_{e\_chp}^t}{\eta_{chp}} \right) \quad (4 - 2)$$

Where  $k_G$  is the price of natural gas; and  $L$  is the low heating value of natural gas.

In this CHP, the optimization objective is to maximize its profit, so first, we got a function to represent the profit of this CHP.

$$\begin{aligned} \max Profit_{CHP} = \\ \sum_{i=1}^{24} \left( price_e^t * P_{e\_chp}^t + price_h^t * P_{h\_chp}^t - k_G * P_{gas\_chp}^t \right) \end{aligned} \quad (4 - 3)$$

The optimization variables in the above optimization model are  $P_{e\_chp}^t$  and  $P_{h\_chp}^t$ , which are the outputs of electricity and heat in this CHP in each hour respectively. As to  $P_{gas\_chp}^t$ , which are determined by the demands, as well as the outputs.  $price_e^t$  and  $price_h^t$  are buying prices of electricity and heat of load in each hour from the EH respectively, which are given by HM of the whole EH.  $k_G$  is the price of gas of the utility. Then we got the whole profit of this CHP, which is the sum of revenue minus the total cost.

### 4.3.2 Gas Boiler System

The GB system absorbs electricity from the utility, then gives thermal energy to our

community buildings, the system structure of GB is shown in Fig.6.

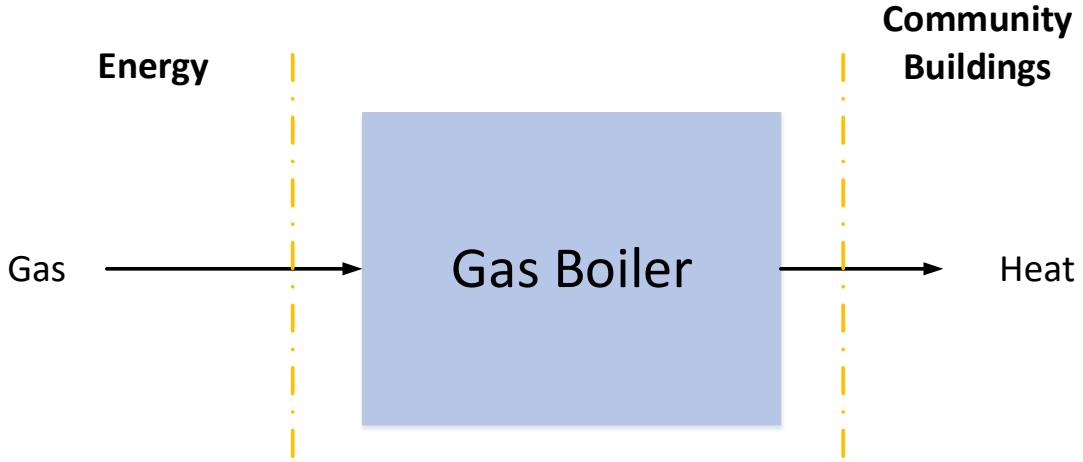

Fig.6. The System Structure of GB

As we can see from above diagram, the GB using heat boiler turns gas from the utility into heat, has same function as CHP, but it is more efficient and more energy-conservation than CHP. And it can absorb energy and output energy at the same time. Moreover, the inputs and outputs of GB have the following relationship:

$$H_{GB_{in}}^t = P_{gas_{GB_{in}}}^t * \eta_{GB} \quad (4 - 4)$$

$$0 \leq P_{gas_{GB_{in}}}^t \leq P_{gas_{GB_{max}}}^t \quad (4 - 5)$$

Where  $\eta_{GB}$  is the transfer efficiency from gas to heat of GB;  $P_{gas_{GB_{in}}}^t$  is the gas consumed by GB per hour,  $H_{GB_{in}}^t$  is the heat turned from  $P_{gas_{GB_{in}}}^t$  at hour  $t$ ;  $P_{gas_{GB_{max}}}^t$  is the maximum heating generation capacity of the GB.

The objective function of GB aims to maximize its own profit:

$$\begin{aligned} \max Profit_{GB} = \\ \sum_{i=1}^{24} (price_h^t * H_{GB_{out}}^t - k_G * P_{gas_{GB_{in}}}^t) \end{aligned} \quad (4 - 6)$$

Where  $k_E^t$  is the price of electricity bought by EH from the utility per hour. The optimization variable in the above optimization model is  $H_{GB_{in}}^t$ , which is the heat output of the GB. The

$price_h^t$  is the price of heat at hour  $t$  determined by HM, then we got the whole profit of this GB, which is the sum of revenue minus the total cost.

### 4.3.3 Electricity Storage System

Electricity Storage System is much easier than Gas Boiler System in some extent, because it just needs to storage electricity, it does not need to transfer one type of energy to another kind of energy. But in the meantime, this feature of ESS determine it cannot absorb electricity from utility and give it to the loads at the same time, it makes ESS more complicated to be analyzed than Gas Boiler. The energy transport structure of ESS is given in Fig.7.

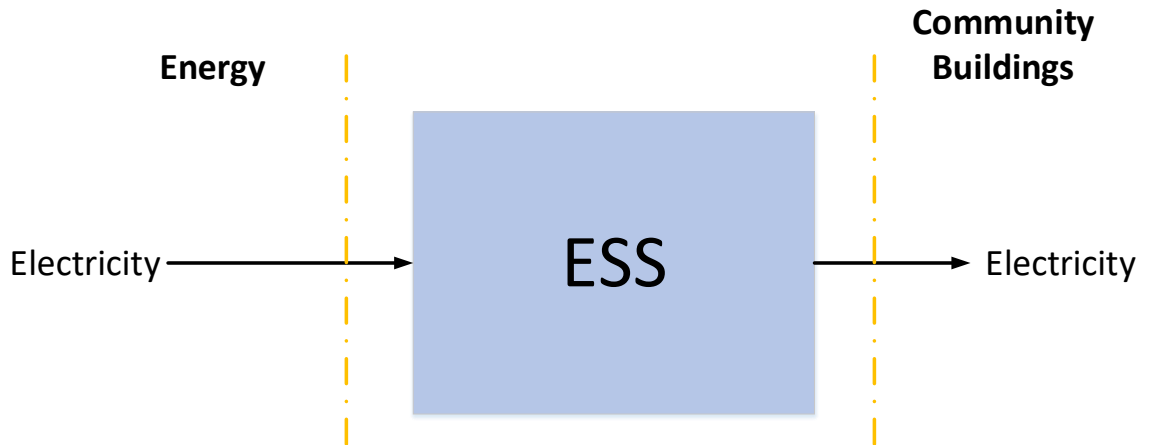

Fig.7. The System Structure of ESS

As is shown in Fig.7, ESS has the same kind of energy in output from input. But there is also have some limitation between these two variables.

$$P_{ess0} = Soc_0 * E_{store\_max} \quad (4 - 7)$$

$$E_{ess}^t = E_{ess}^{t-1} + P_{ess}^t \quad (4 - 8)$$

$$Soc^t = \frac{E_{ess}^t}{E_{store\_max}} \quad (4 - 9)$$

$$Soc_{ess\_min} \leq Soc^t \leq Soc_{ess\_max} \quad (4 - 10)$$

$$0 \leq E_{ess}^t \leq E_{store\_max} \quad (4 - 11)$$

$$-P_{max\_ess} \leq P_{ess}^t \leq P_{max\_ess} \quad (4 - 12)$$

Where  $Soc_0$  is the state of charge level of the last hour of the previous day ;  $P_{ess0}$  is the initial stored value of electricity of ESS , which is left over from the last hour of the previous day ;  $E_{store\_max}$  is the maximum electricity storage capacity of the ESS;  $E_{ess}^t$  is the value of the stored electricity at hour t, which is influenced by the electricity consumption of last hour of it;  $Soc^t$  is the state of charge level at hour t;  $Soc_{ess\_min}$  is the minimum value of the state of charge level;  $Soc_{ess\_max}$  is the maximum value of the state of charge level;  $P_{ess}^t$  is the value of the exchanged electricity from the utility at the hour t, the negative value means the state of energy output and the positive value means the state of energy input, more importantly, the state of input and output cannot happen at the same time, which means this parameter can just have one value at the hour t;  $P_{max\_ess}$  is the maximum of the amount of electricity exchanged from the utility at per hour.

The objective function of ESS aims to maximize its own profit:

$$\begin{aligned} \max Profit_{ESS} = \\ \sum_{i=1}^{24} (price_e^t * P_{ess}^t - k_E^t * P_{ess}^t) \end{aligned} \quad (4 - 13)$$

Where  $k_E^t$  is the price of electricity bought by EH from the utility per hour. The optimization variable in the above optimization model is  $E_{ess\_out}^t$  , which is the electricity output of the ESS. The  $price_e^t$  is the price of electricity at hour t determined by HM, then we got the whole profit of this ESS, which is the sum of revenue minus the total cost.

#### 4.3.4 PV

As illustrated before, we have PV panels in our community, and it also contribute to the electricity output of the whole EH. But it has a difference from CHP, GB and ESS, it belongs to the EH and administrated by HM directly. So we do not need to make the profit of it maximized. On the other hand, the outputs of PV are uncontrollable, it has feature of intermittency and uncertainty. We give the profit produced by PV to the EH, and dispatched by HM.

### 4.4 Optimization Model of the Whole EH

A bilevel sophisticated programming problem (BSPP) model of the decision-making of an energy hub manager is presented. Hub manager seeks ways to minimize its transactive cost of buying electricity and gas from the utility HM has to make decisions about:

- 1) The level of involvement in forward contracts, electricity pool markets, and natural gas networks;
- 2) The electricity and heat offering prices to the clients.

On the other hand, the prosumers in this EH try to maximize their profit. This two-agent relationship is presented in this EH. The detail of this bilevel model is discussed below.

At first, electricity and natural gas networks are coordinated at the transmission level for accommodating the large penetration of solar power in multi-carrier energy system (MES). The distribution level MES coordinated energy conversion and storage to jointly electricity and heat loads. The transmission level MES is modeled using detailed network equations while the distribution level MES is modeled as a device with multiple input/output ports based on EH

model.

The first-level problem which schedules the hourly unit commitment is solved in the lower level, while upper level solves the second-level problem to realize its objective and determine the ultimate prices of selling prices of electricity and heat of the EH vary on time.

According to the above discussions, the optimization objective under the cooperative mode and each prosumer's optimization objective are connected. The figure shows the interactions of this bilevel optimized problem between the HM, prosumers and loads is Fig.8.

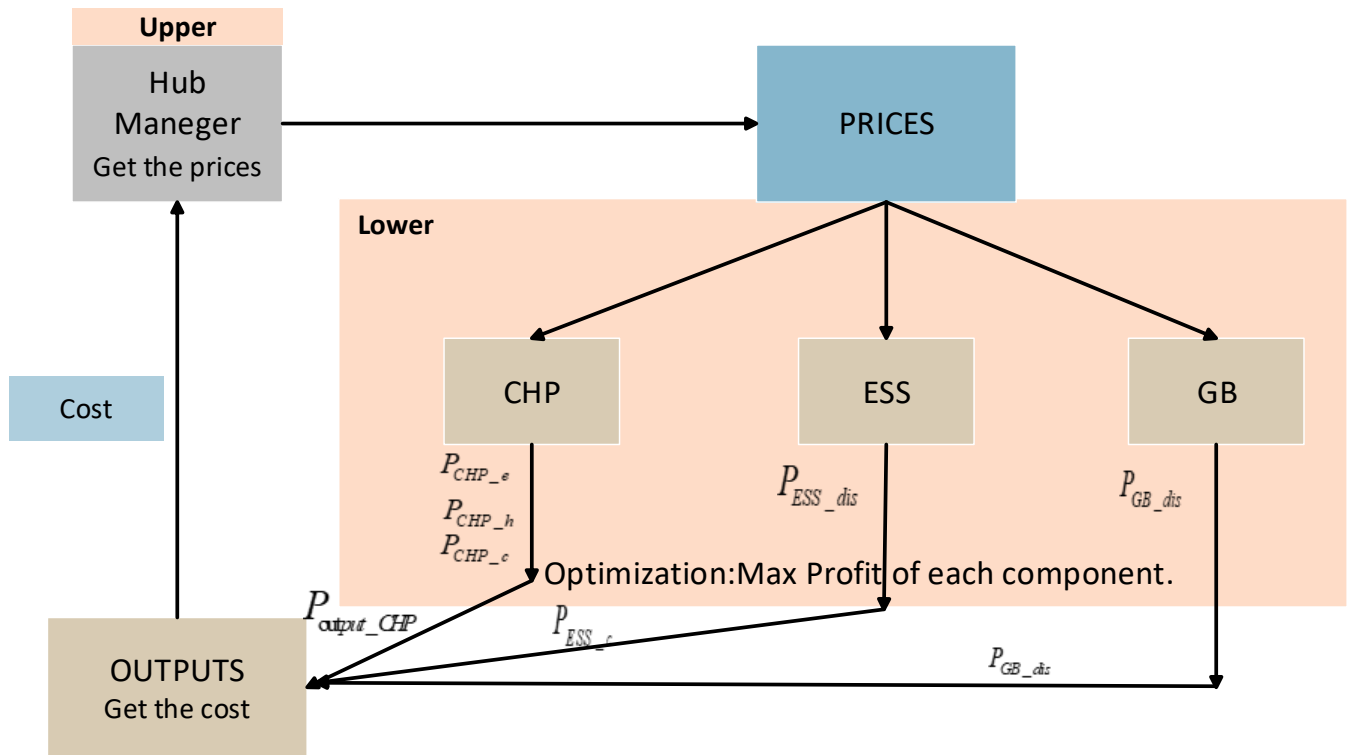

Fig.8. The Interaction Scheme Between Upper Layer and Lower Layer

As we can see from Fig.8, HM gives prices of these three kinds of energies to each prosumer, then they can use the given prices and the buying prices of electricity and gas from the utility to do the optimization to realize their profits maximized, after their optimization, we can get the optimized outputs from all prosumers. At the meantime, the HM received their outputs. After got outputs of prosumers, HM adjust the prices of energies to fulfill the demands of loads.

To be specifically, if the outputs are less than load demands, then we need to gain buying prices of energies in order to get more electricity or heat, it depends on the prices of each energy. Vice versa, if the outputs go beyond load demands, we need to reduce buying prices.

For the upper level, the optimization objective function is to minimize the transactive cost of the whole EH.

#### 4.4.1 Objective function of Optimization of Bilevel Model

$$\min C =$$

$$C_G + C_E = \sum_{t=1}^{24} \left\{ k_G * \left[ (1/L) * \left( \frac{P_{chp}^t}{\eta_{chp}} \right) + P_{GB}^t \right] \right\} + \sum_{t=1}^{24} k_e^t * P_{e_{utility}}^t \quad (4 - 14)$$

We used the optimization model to minimize the total cost of the EH buying energy from the utility.

The optimization variables in the above optimization model are  $P_{chp}^t$ ,  $P_{GB}^t$  and  $P_{e_{utility}}^t$ , which are the electricity output of the CHP, the gas consumed by the GB and the electricity consumed by the EH from the utility.

They satisfy the following constraints:

$$P_{chp}^t = \left( \frac{\sum_{i=1}^n l_{hi}^t}{\delta_{heat}} \right) * \frac{\eta_{chp}}{1 - \eta_{chp} - \eta_{loss}} \quad (4 - 15)$$

$$H_{GBin}^t = P_{gas_{GBin}}^t * \eta_{GB} \quad (4 - 16)$$

$$P_{chp}^t + P_{e_{utility}}^t + P_{e_{ess}}^t + P_{e_{pv}}^t = l_e^t \quad (4 - 17)$$

$$P_{h_{chp}}^t + P_{GB}^t = l_h^t \quad (4 - 18)$$

The equations above are the conservation of energy consumed by load including the heat and the electricity.

For the lower level, the optimization objective functions are discussed before.

$$\begin{aligned} \max Profit_{CHP} = \\ \sum_{i=1}^{24} (price_e^t * P_{echp}^t + price_h^t * P_{hchp}^t - k_G * P_{gaschp}^t) \end{aligned} \quad (4 - 19)$$

$$\begin{aligned} \max Profit_{GB} = \\ \sum_{i=1}^{24} (price_h^t * H_{GBout}^t - k_G * P_{gasGBin}^t) \end{aligned} \quad (4 - 20)$$

$$\begin{aligned} \max Profit_{ESS} = \\ \sum_{i=1}^{24} (price_e^t * P_{eess}^t - k_E^t * P_{eess}^t) \end{aligned} \quad (4 - 21)$$

From the discussion above, we use a bilevel optimization model to realize our goal, to minimize the total transactive cost and maximize each prosumer's profit in the meantime. Then we shall begin our case study.

# Chapter 5 Case Study

## 5.1 Basic Data

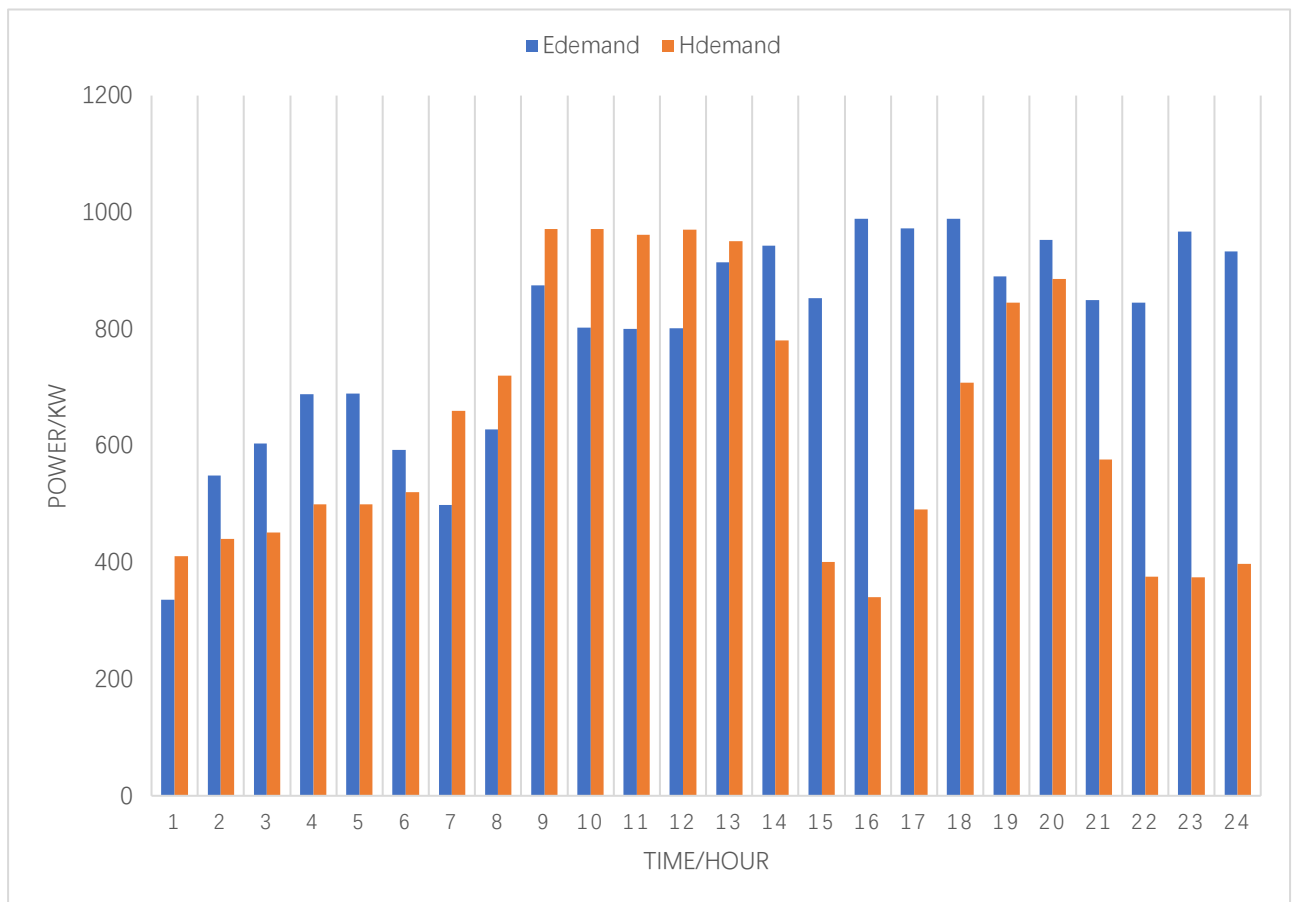

Fig.9. Total power curves of all prosumers in a typical day

The basic data including the demand of the electricity and heat in the community of each hour within a day.

The electricity of PV outputs in 24 hours shows in Fig.10.

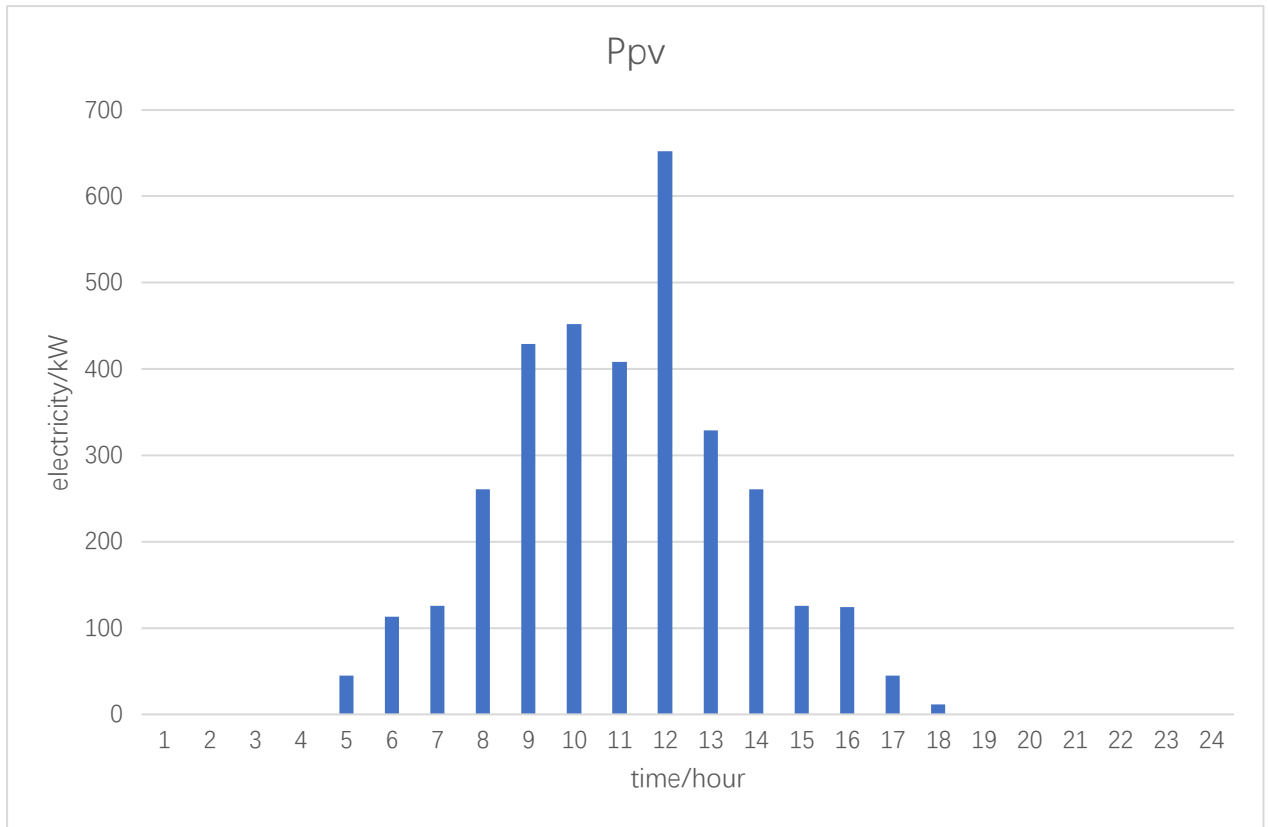

Fig.10. The electricity generated by PV

The proposed model is applied in a CES, we have buildings with roof-top PV panels in our community. Before we do optimization, the parameters in this community are shown in Table 2.

Table.2. The Related Parameters

Name of Parameter	Value of Parameter	Name of Parameter	Value of Parameter
$L$	0.8	$\delta_{cool}$	1.2
$k_G$	0.3 dollar/ $m^3$	$\eta_{chp}$	0.4
$\delta_{heat}$	0.8	$\eta_{loss}$	0.05
$\eta_{gas-GB}$	0.6	$E_{store\ max}$	500
$P_{gas\_GB\_max}^t$	300	Pmax_ess	50
$\mu_{ESS}$	0.05	Soc <sub>ess_max</sub>	0.8

Name of Parameter	Value of Parameter	Name of Parameter	Value of Parameter
$\eta_{ESS\_in}$	0.9	$Soc_{ess\_min}$	0.2
$\eta_{ESS\_out}$	0.8	$Soc_0$	0.2

The price of electricity bought from the utility in that certain day is shown in Fig.11.

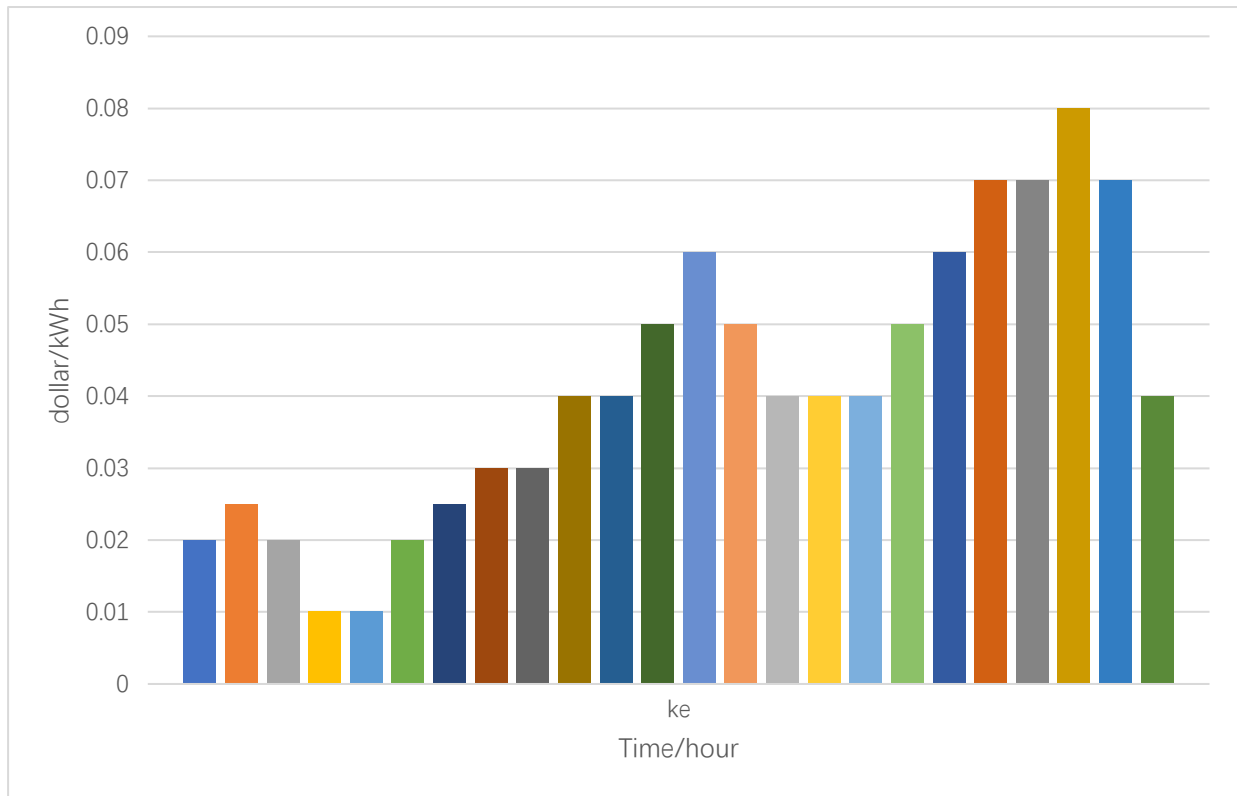

Fig.11. The Electricity Prices of the Utility

The prices of electricity of the utility are vary on hours, with the different load demands of the electricity in community.

## 5.2 Optimization Dispatch

In this chapter, the optimization dispatch we talk about is the EH system at the community level without the TE. We do not take the prices of electricity and heat and the profits of the components in this EH into consideration. So, the optimization just uses the basic data from Fig.9 and the related parameter in Table.2. We use MATLAB software and Yamip solver to

do the simulation with mixed integer method.

The objective function is shown below.

$$\min C = C_G + C_E = \sum_{t=1}^{24} \left\{ k_G * \left[ (1/L) * \left( \frac{P_{echp}^t}{\eta_{chp}} \right) + P_{GB}^t \right] \right\} + \sum_{t=1}^{24} k_e^t * P_{eutility}^t \quad (5-1)$$

Where  $k_G$  is the price of the gas of the utility,  $k_e^t$  is the price of electricity of the utility at hour t; L is the low heating value of natural gas;  $P_{echp}^t$  is the output of the electricity from the CHP;  $\eta_{chp}$  is the power generation efficiency of the microturbine of the CHP;  $P_{GB}^t$  is the gas consumed by GB at hour t;  $P_{eutility}^t$  is the electricity consumed by load from the utility directly at hour t;  $P_{eessin}^t$  is the electricity absorbed by ESS from the utility at hour t. The sum over all 24 hours in a day is the final total cost.

As is shown above, the objective function is to minimize the total cost of the EH, and the cost consists of two parts: the cost of buying electricity and gas from the utility.

As for load in the community, also can be divided into two parts: heat and electricity.

For the heat load, it can be supplied by the CHP and the GB at the same time, they satisfy the function as follows:

$$P_{hchp}^t + P_{GB}^t = l_h^t \quad (5-2)$$

For the electricity load, there are four ways for them to be fulfilled: the CHP, the utility, PV and the ESS:

$$P_{echp}^t + P_{eutility}^t + P_{eess}^t + P_{epv}^t = l_e^t \quad (5-3)$$

Some inequality constraints of this optimization model:

$$0 \leq P_{hchp}^t \leq P_{hchp}^{max} \quad (5-4)$$

$$-P_{eess}^{max} \leq P_{eess}^t \leq P_{eess}^{max} \quad (5-5)$$

$$0 \leq P_{GB}^t \leq P_{GB}^{max} \quad (5 - 6)$$

$$0 \leq P_{echp}^t \leq P_{echp}^{max} \quad (5 - 7)$$

$$0 \leq E_{store}^t \leq E_{store}^{max} \quad (5 - 8)$$

Where  $P_{h\_chp}^{max}$  and  $P_{e\_chp}^{max}$  are the upper limits of the output of heat and electricity of the CHP respectively, which are actually have some inner connection between them;  $P_{GB}^{max}$  is the upper limit of the output of the heat of GB;  $E_{store}^{max}$  is the maximum of the electricity stored by ESS.

Equality constraints:

$$P_{echp}^t = \left( \frac{\sum_{i=1}^n l_{hi}^t}{\delta_{heat}} \right) * \frac{\eta_{chp}}{1 - \eta_{chp} - \eta_{loss}} \quad (5 - 9)$$

$$P_{gas\_chp}^t = \frac{P_{echp}^t}{\frac{\eta_{chp}}{L}} \quad (5 - 10)$$

Where  $l_{hi}^t$  is the heating load satisfied by the CHP at the hour t;  $\delta_{heat}$  is heating coefficient of the waste heat boiler;  $\eta_{loss}$  is heat loss coefficient in the CHP system;  $P_{gas\_chp}^t$  is the gas consumed by CHP at the hour t.

The result of the optimization is shown in Fig.12-Fig.17.

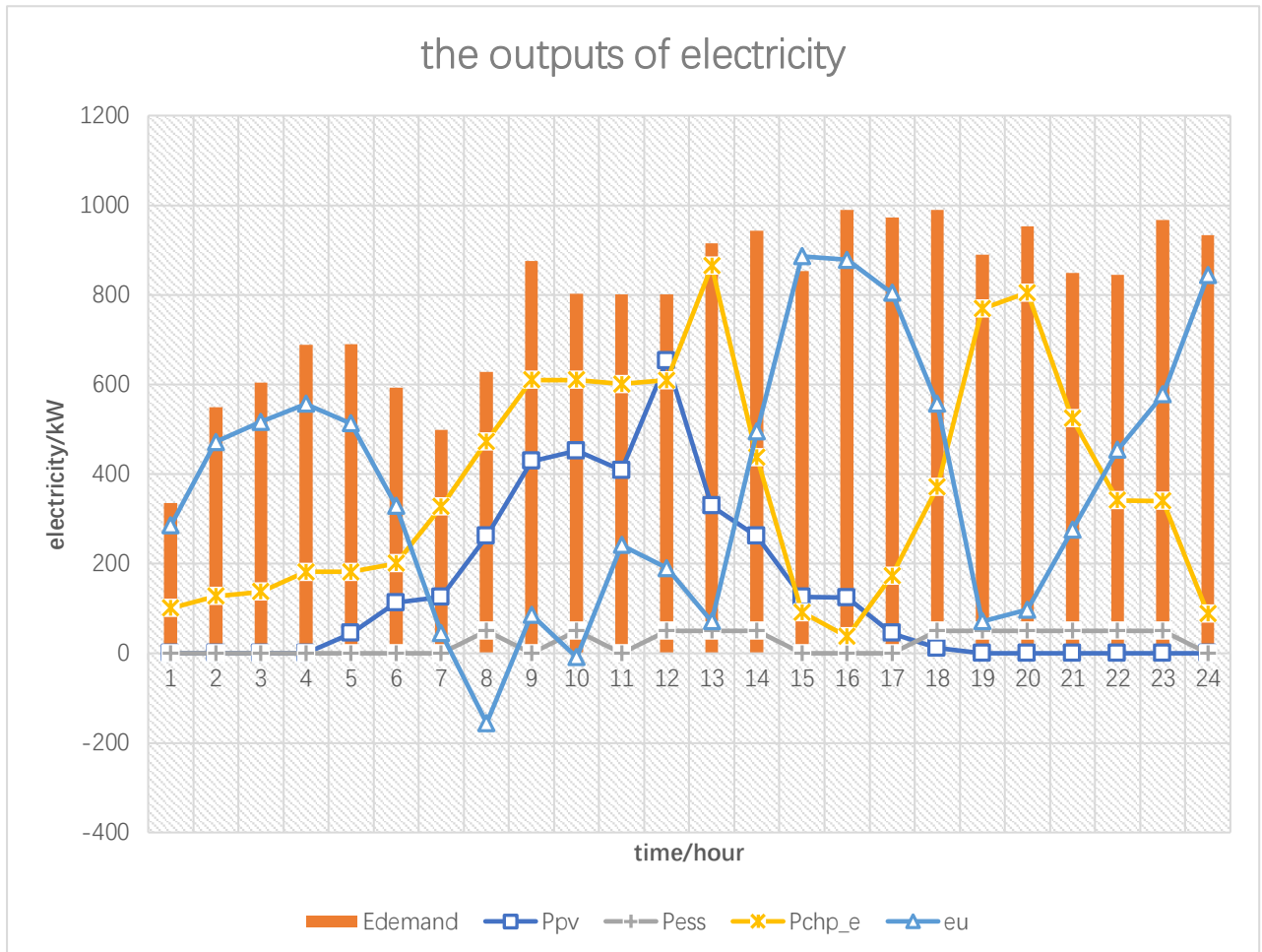

Fig.12. The Outputs of Electricity of the EH

As we can see from the diagram above, the electricity load is fulfilled by four parts in the EH together: PV, ESS, CHP and the utility. Here, we assume the EH can sell electricity back to the utility to make profit, which shows in the form of negative in the chart above. If we put Fig.11 and Fig.10 together, we can have a better understanding of the optimized results. The electricity outputs of each component in this EH not only depend on the load demand and the generation of PV, but also can be great influenced by the price of the electricity and gas of the utility. The output of electricity from CHP would grow when the price of electricity of the utility is much higher than the price of gas in some extent, the HM would increase the output of CHP and even store part of it into ESS for the hours needed.

Then outputs of the heat of the whole EH are shown in the Fig.13.

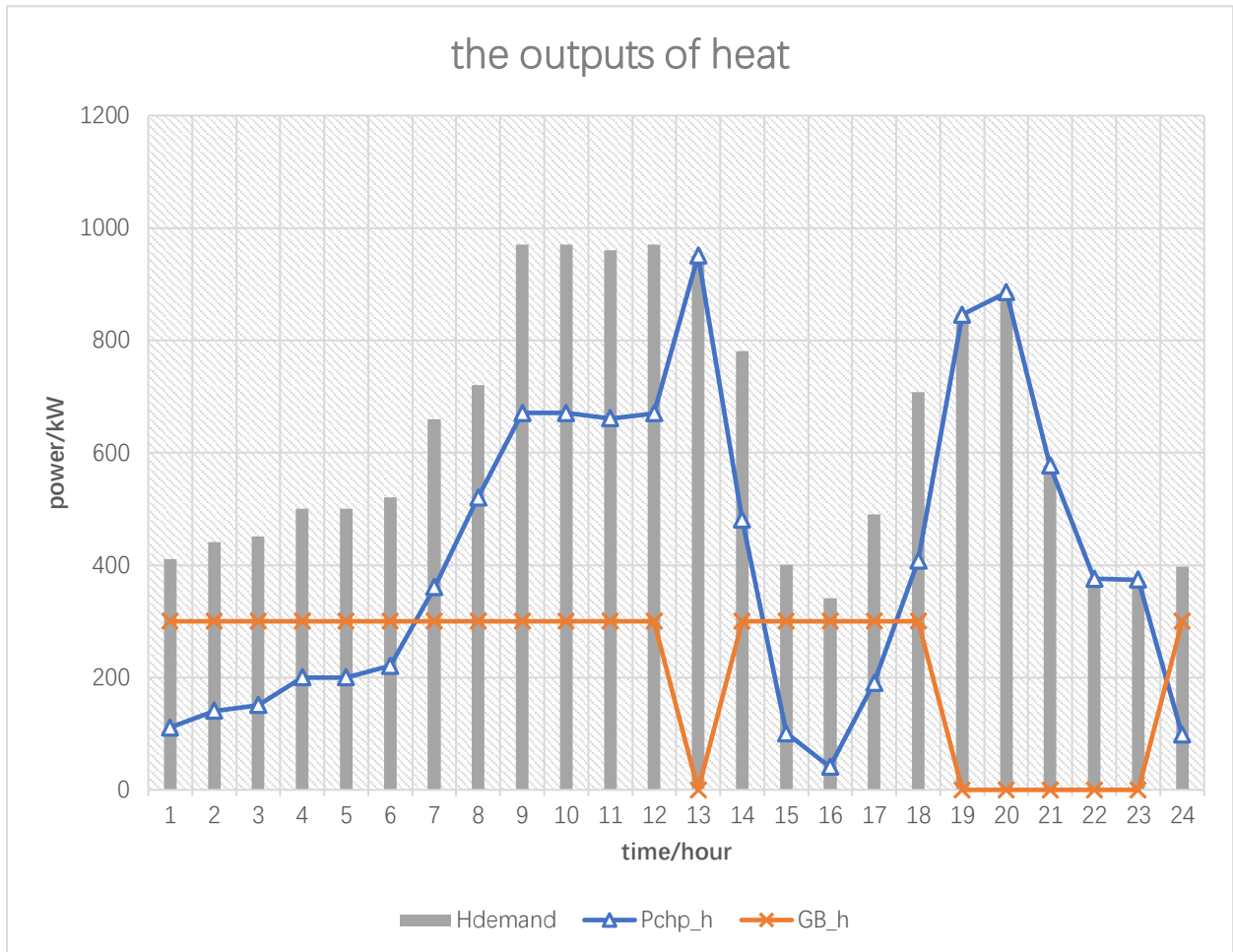

Fig.13. the Outputs of Heat in the EH

As we can see above, the heating load demand can be satisfied by the CHP and the GB at the same time. Like we said before, combine Fig.12 with Fig.10, we can find some connection and conflict between the heating output of the CHP and the output of the GB. And it has significant influences on the curve of the electricity outputs of the EH in some extent. For example, when the prices of electricity of the utility are high, the CHP would increase its outputs of electricity in order to minimize the total cost of the whole EH. At the meantime, the heating outputs of CHP rise because of the connection between the electricity output and the heating output of the CHP. But the heating load demands are limited, under this condition, the GB would decrease its outputs of heat for the energy conservation.

Then let us see the outputs of each components in this EH.

### 5.2.1 ESS

The electricity storage system absorb energy from the utility in particular hours, it depends on the load demand and electricity price of the utility. It has initial stored electricity which is left by the last hour of the previous day of it. In this model, we set this initial value of ESS equal to the minimum storage level of it. Then we can see from the chart below, at the first hour of this specific day, the ESS's charge level is 0.3, exceeding the minimum value of 0.2 by 0.1. In other word, the ESS absorb 50 kW of electricity in the first hour of this particular day.

Because the electricity input and output of ESS cannot be the same time, so we use linprog solver to solve this mixed integer problem here.

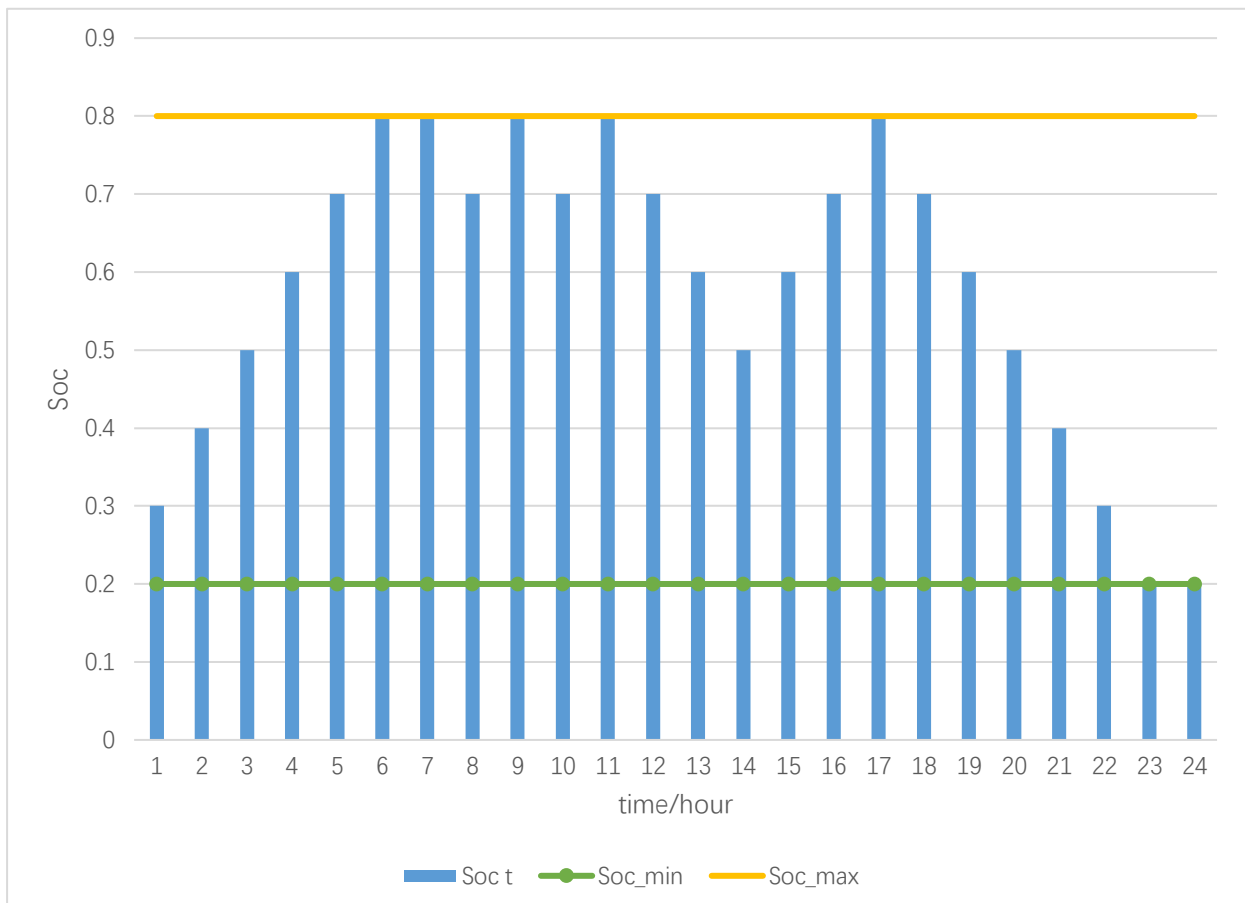

Fig.14. Status of Charge level of ESS

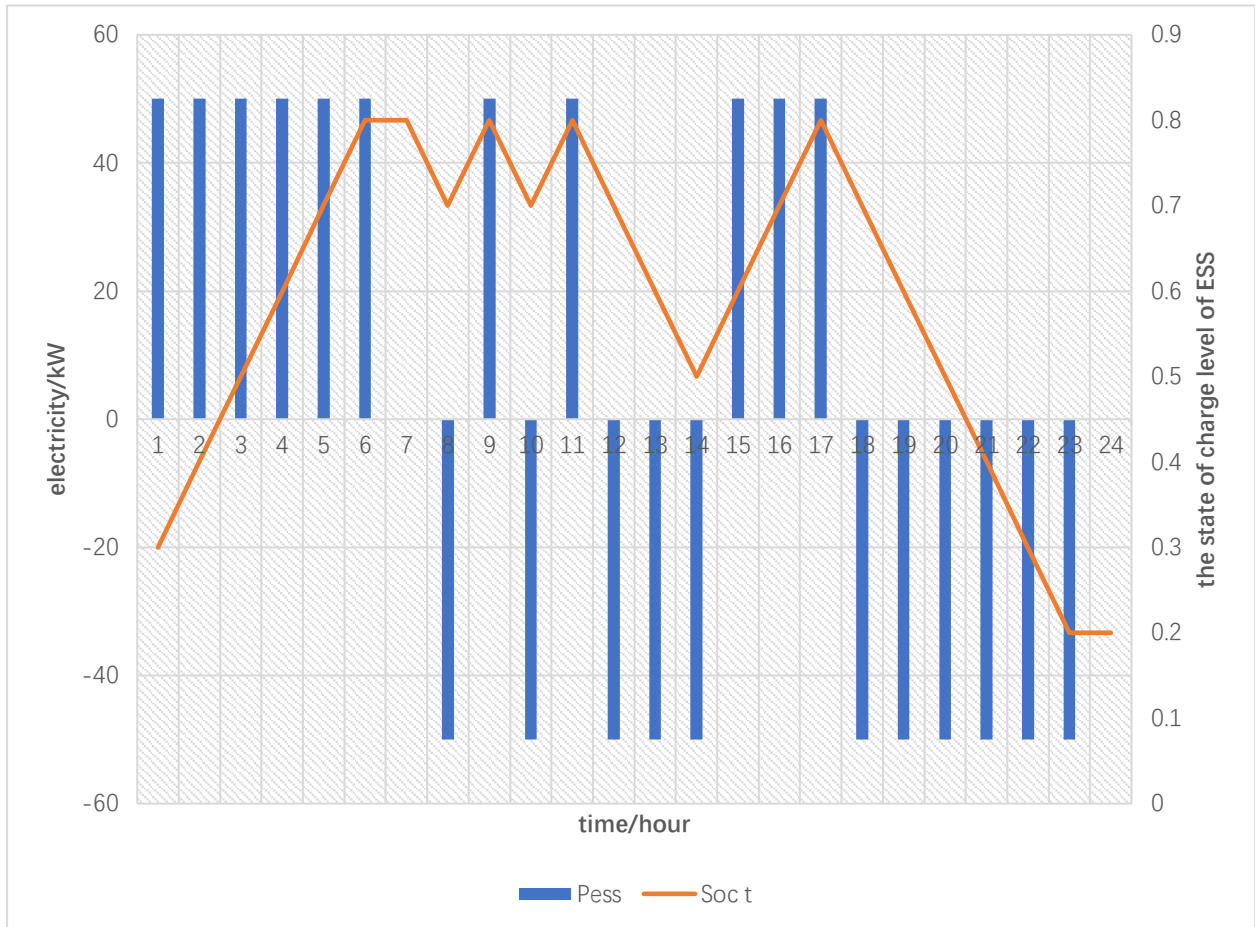

Fig.15. the Operation of ESS in the 24 hours

### 5.2.2 CHP

The generated energy of CHP has two kinds of energy in this model: electricity and heat. They satisfy the energy output formula of CHP, so their output curves are going to be similar. But because they have different conversion rates, their values are not exactly the same, they are just in constant proportion to each other. In other word, if the heat demand is high enough and CHP need to increase its heating output to satisfy the load, then the electricity production of CHP also rises. Then the ESS also need to adjust its decision it made to keep the conservation of energy in this way. It reflects the cooperation between components in the EH in some extent.

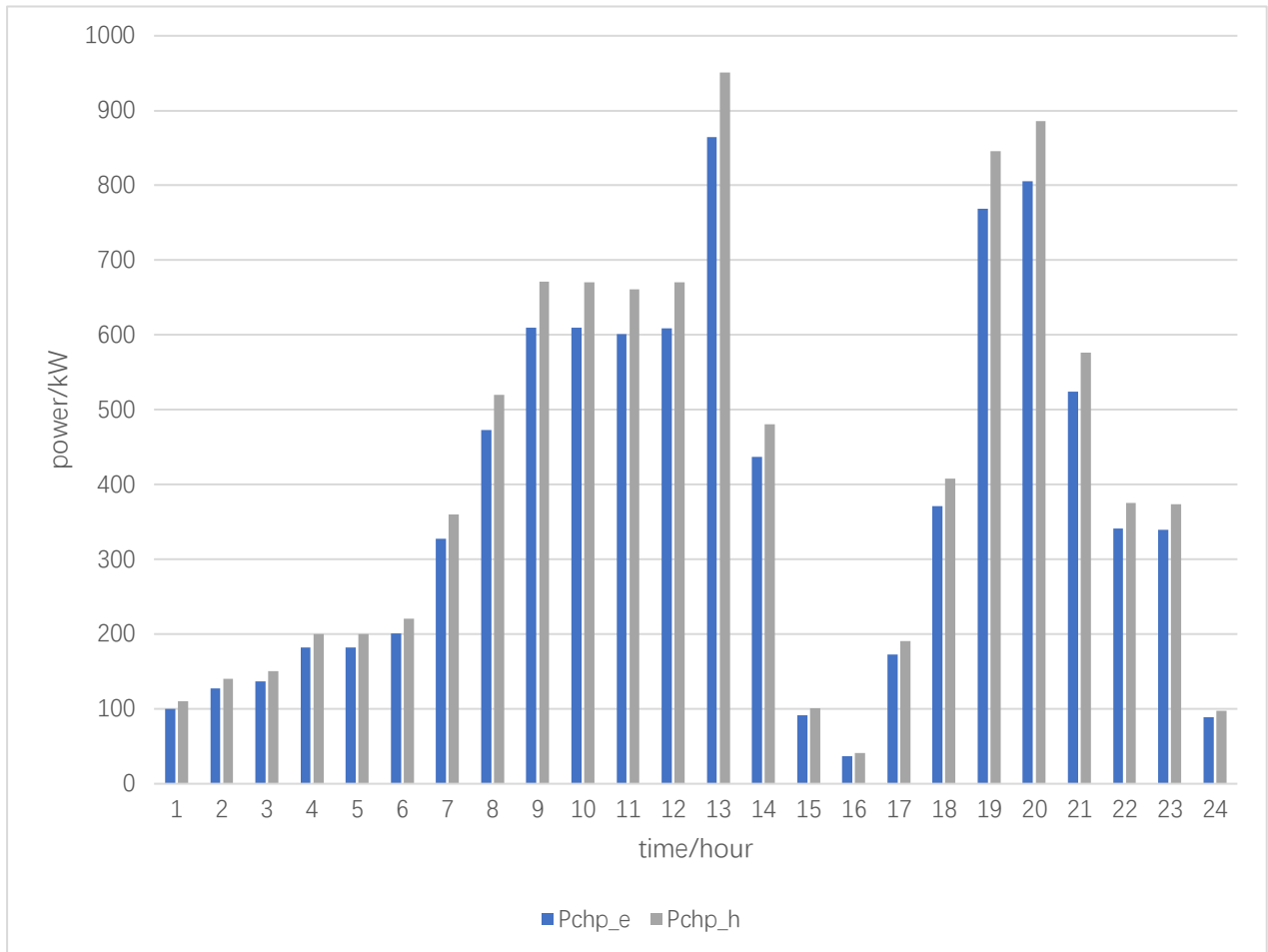

Fig.16. the Output of the CHP

### 5.2.3 GB

The energy generated by GB are much easier to be analyzed, because it has the only kind of energy to produce. Gas is transferred to heat directly. But it can be very complicated, because it can be affected in many ways. As we can see from the figure below, when the price of electricity is high, the curve of the output of heat produced by CHP would go down because of the decrease of the output of the electricity generated by CHP. With the emergence of this situation, the output of GB would increase.

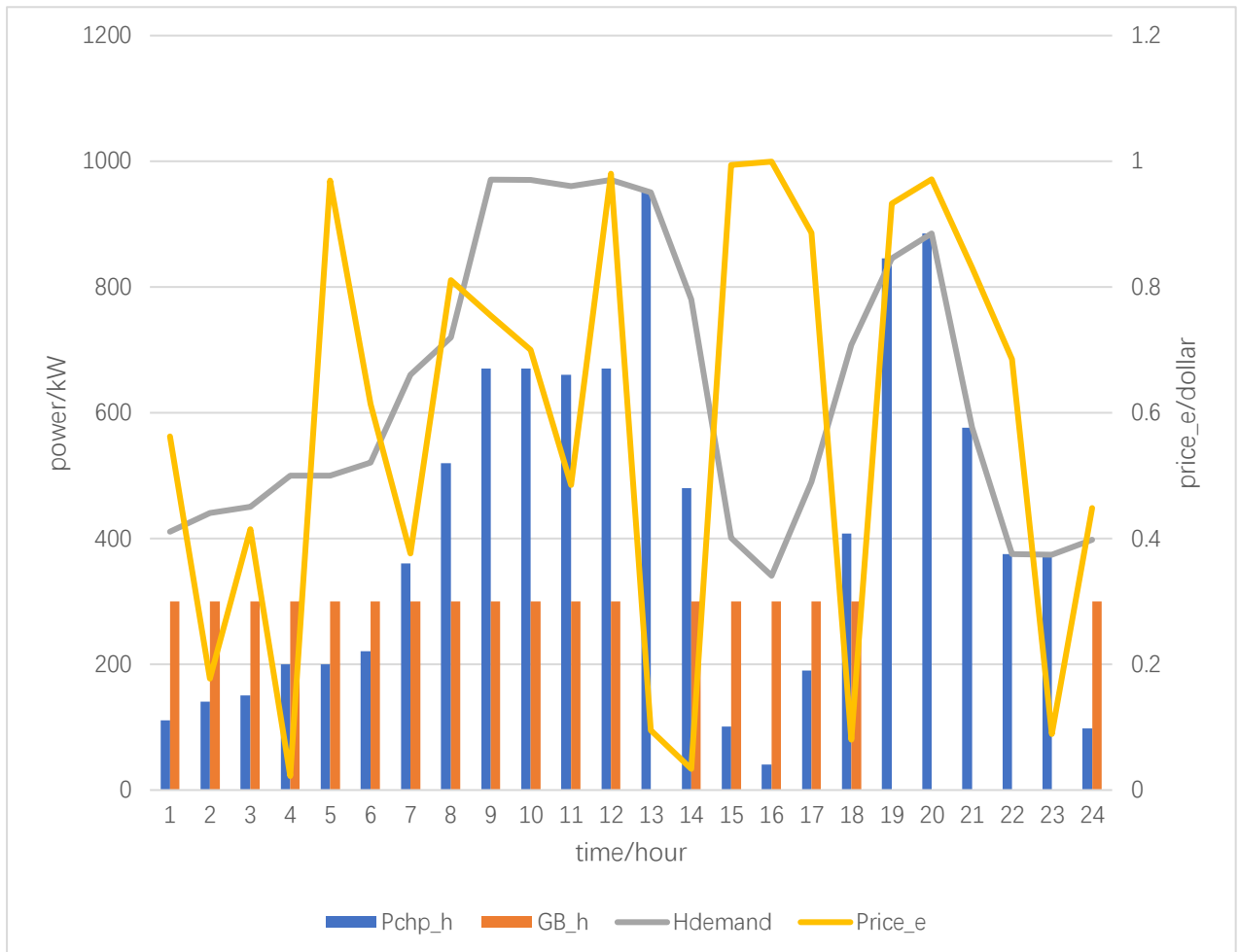

Fig.17. the relationship between the output of the CHP and the GB

### 5.3 Optimization Dispatch with Transactive Energy

In this model, we combine the idea of TE with our MCES. We build a sophisticated bilevel interactive model to complete day-ahead dispatch.

Like we discussed before, in this TE model, we add the concept ‘value’ into the model in order to do the optimized dispatch better, and the ‘value’ reflected as the price of multi-carrier energy here. The signal of price guides the decision making of every component in the EH. In this model, we use Karush–Kuhn–Tucker (KKT) conditions turn this bilevel problem into a solvable linear problem.

### 5.3.1 Karush–Kuhn–Tucker (KKT) conditions

In mathematical optimization, the KKT conditions also called Kuhn–Tucker conditions, it is a classic way of solving optimization problems. The optimization problem we refer to here is usually to find the minimum value of a given function in the specified scope. When talk about KKT, it always reminds us of the Lagrangian multiplier. They both are methods for solving optimization problems, but their application conditions are different. KKT method is more applicable to us here.

KKT conditions are necessary for solving problems in nonlinear programming, provided that some regularity conditions are satisfied. KKT allows to be used with inequality constraints, it generalizes the method of Lagrangian multiplier in nonlinear programming, which allows only equality constraints.

Consider the following nonlinear minimization or maximization problem:

Optimize  $f(x)$

$$\text{Subject to } g_i(x) \leq 0, \quad (5-11)$$

$$h_j(x) = 0, \quad (5-12)$$

Where  $x$  is the optimization variable,  $f$  is the objective or utility function;  $g_i (i = 1, \dots, m)$  are the inequality constraint functions, and  $h_j (j = 1, \dots, n)$  are the equality constraints functions.

For solving the maximizing problem, the objective can be illustrated by function 5-13.

$$\nabla f(x^*) = \sum_{i=1}^m \mu_i \nabla g_i(x^*) + \sum_{j=1}^n \lambda_j \nabla h_j(x^*), \quad (5 - 13)$$

For the minimizing problem, we just need to add a minus before the  $\nabla f(x^*)$ .

To solve these questions, we need to know feasibility of them first.

Primal feasibility:

$$g_i(x^*) \leq 0, \text{ for } i = 1, \dots, m \quad (5 - 14)$$

$$h_j(x^*) = 0, \text{ for } j = 1, \dots, n \quad (5 - 15)$$

Dual feasibility:

$$\mu_i \geq 0, \text{ for } i = 1, \dots, m \quad (5 - 16)$$

Complementary slackness:

$$\mu_i g_i(x^*) = 0, \text{ for } i = 1, \dots, m \quad (5 - 17)$$

In the particular case  $m=0$ , i.e., when there are no inequality constraints, this problem can be turned in to a question with Lagrange conditions.

In the model we illustrated above, the related constraints after we put the KKT Conditions into our model are shown below:

1) CHP

The profit model of the CHP:

$$\begin{aligned} \max Profit_{CHP} = & \\ & \sum_{i=1}^{24} (price\_e^t * P_{e\_chp}^t + price\_h^t * P_{h\_chp}^t - k_G * P_{gas\_chp}^t) = \\ & \sum_{i=1}^{24} (price_e^t * P_{e\_chp}^t + price_h^t * P_{e\_chp}^t * \frac{1 - \eta_{chp} - \eta_{loss}}{\eta_{chp}} * \eta_{heat} - k_G * \frac{P_{e\_chp}^t}{L \cdot \eta_{chp}}) \end{aligned} \quad (5 - 18)$$

For stationary constraints, the function above can be transferred as below.

$$price_e^t + price_h^t * \frac{1 - \eta_{chp} - \eta_{loss}}{\eta_{chp}} * \eta_{heat} - \frac{k_G}{L \cdot \eta_{chp}} + c_{\mu l} - c_{\mu u} = 0 \quad (5 - 19)$$

$c_{\mu l}$  and  $c_{\mu u}$  are constrain dual variables of lower bound and upper bound respectively.

The main inequal constraint of the profit model can be illustrated as follows:

$$0 \leq P_{chp_e} \leq P_{max} \quad (5 - 20)$$

For complementary slackness

$$c\mu_l \cdot (P_{chpe}) = 0 \quad (5 - 21)$$

$$c\mu_u \cdot (P_{max} - P_{chpe}) = 0 \quad (5 - 22)$$

In order to guarantee this condition, we used mixed integer method:

$$0 \leq c\mu_l \leq cwl \cdot M \quad (5 - 23)$$

$$0 \leq P_{chpe} \leq (1 - cwl) \cdot M \quad (5 - 24)$$

$$0 \leq c\mu_u \leq cwu \cdot M \quad (5 - 25)$$

$$0 \leq P_{max} - P_{chpe} \leq (1 - cwu) \cdot M \quad (5 - 26)$$

$$cwl + cwu = 1 \quad (5 - 27)$$

$cwl$  and  $cwu$  are integer variables.

$M$  is a big enough number, here we used big  $M$  Method which we will introduced in my next section.

## 2) ESS

The profit model of the ESS:

$$\begin{aligned} \max Profit_{ESS} = \\ \sum_{i=1}^{24} price_e^t * E_{ess}^t - k_E^t * E_{ess}^t \end{aligned} \quad (5 - 28)$$

For stationary constraints, the function above can be transferred as below.

$$price_e^t - k_E^t + e\mu_l - e\mu_u = 0 \quad (5 - 29)$$

$e\mu_l$  and  $e\mu_u$  are constrain dual variables of lower bound and upper bound respectively.

The main inequal constraint of the profit model can be illustrated as follows:

$$-P_{ess}^{max} \leq E_{ess}^t \leq P_{ess}^{max} \quad (5 - 30)$$

$$Soc_{min} \leq Soc_t \leq Soc_{max} \quad (5 - 31)$$

For complementary slackness

$$e\mu_l \cdot (E_{ess}^t + P_{ess}^{max}) = 0 \quad (5 - 32)$$

$$e\mu_u \cdot (P_{ess}^{max} - E_{ess}^t) = 0 \quad (5 - 33)$$

In order to guarantee this condition, we used mixed integer method:

$$0 \leq e\mu_l \leq ewl \cdot M \quad (5 - 34)$$

$$0 \leq E_{ess}^t + P_{ess}^{max} \leq (1 - ewl) \cdot M \quad (5 - 35)$$

$$0 \leq e\mu_u \leq ewu \cdot M \quad (5 - 36)$$

$$0 \leq P_{ess}^{max} - E_{ess}^t \leq (1 - ewu) \cdot M \quad (5 - 37)$$

$$ewl + ewu = 1 \quad (5 - 38)$$

$ewl$  and  $ewu$  are integer variables.

### 3) GB

The profit model of the GB:

$$\begin{aligned} \max Profit_{GB} = \\ \sum_{i=1}^{24} (price_h^t * H_{GBout}^t - k_G * P_{gasGBin}^t) = \\ \sum_{i=1}^{24} \left( price_h^t * H_{GBout}^t - k_G * \frac{H_{GBout}^t}{\eta_{gb}} \right) \end{aligned} \quad (5 - 39)$$

For stationary constraints, the function above can be transferred as below.

$$price_h^t - k_G * \frac{1}{\eta_{gb}} + g\mu_l - g\mu_u = 0 \quad (5 - 40)$$

$g\mu_l$  and  $g\mu_u$  are constrain dual variables of lower bound and upper bound respectively.

The main inequal constraint of the profit model can be illustrated as follows:

$$0 \leq P_{gbh} \leq P_{GB}^{max} \quad (5 - 41)$$

For complementary slackness

$$g\mu_l \cdot (P_{gb_h}) = 0 \quad (5 - 42)$$

$$g\mu_u \cdot (P_{GB}^{max} - P_{gb_h}) = 0 \quad (5 - 43)$$

In order to guarantee this condition, we used mixed integer method:

$$0 \leq g\mu_l \leq gwl \cdot M \quad (5 - 44)$$

$$0 \leq P_{gb_h} \leq (1 - gwl) \cdot M \quad (5 - 45)$$

$$0 \leq g\mu_u \leq gwu \cdot M \quad (5 - 46)$$

$$0 \leq P_{GB}^{max} - P_{gb_h} \leq (1 - gwu) \cdot M \quad (5 - 47)$$

$$gwl + gwu = 1 \quad (5 - 48)$$

$gwl$  and  $gwu$  are integer variables.

### 5.3.2 Big M Method

The Big M method is a method of solving linear programming problems using the simplex algorithm. After adding artificial variables to the constraints of the linear programming problem, it is required to add one M as the coefficient in the objective function accordingly.

In the maximization problem, negative M is assigned to the artificial variable as its coefficient. In a minimization problem, an artificial variable is assigned an M as its coefficient, and M is a positive number of arbitrarily large (not infinite). M is treated as an algebraic symbol involved in the operation and solved by the simplex method

In this model, we set the M as  $10^6$ .

### 5.3.3 Optimization of the EH with TE

After adding plenty of variables into the model in Fig.8, this bilevel model can be turned

into a single level problem. The functions in the lower level are expressed in terms of variables shown in our new model. The difference between this model and the model in 4.3.1 is that this optimization model considers the components are optimized making the profits of their own. In this chapter, we present a mathematically proven as well as practical approach for bidding of an autonomous smart MCES community.

Most importantly, the objective function of the model in chapter 4.2 is aimed to minimize the cost of the buying price of the electricity and gas from the utility of the whole EH. But the objective function here is to minimize the buying price of the electricity and heat from the EH of the load and maximize the profits of each components in the whole EH.

### 5.3.4 Optimization Results

Input the basic data in chapter 4.1, we got the results show in Fig.18- Fig.23.

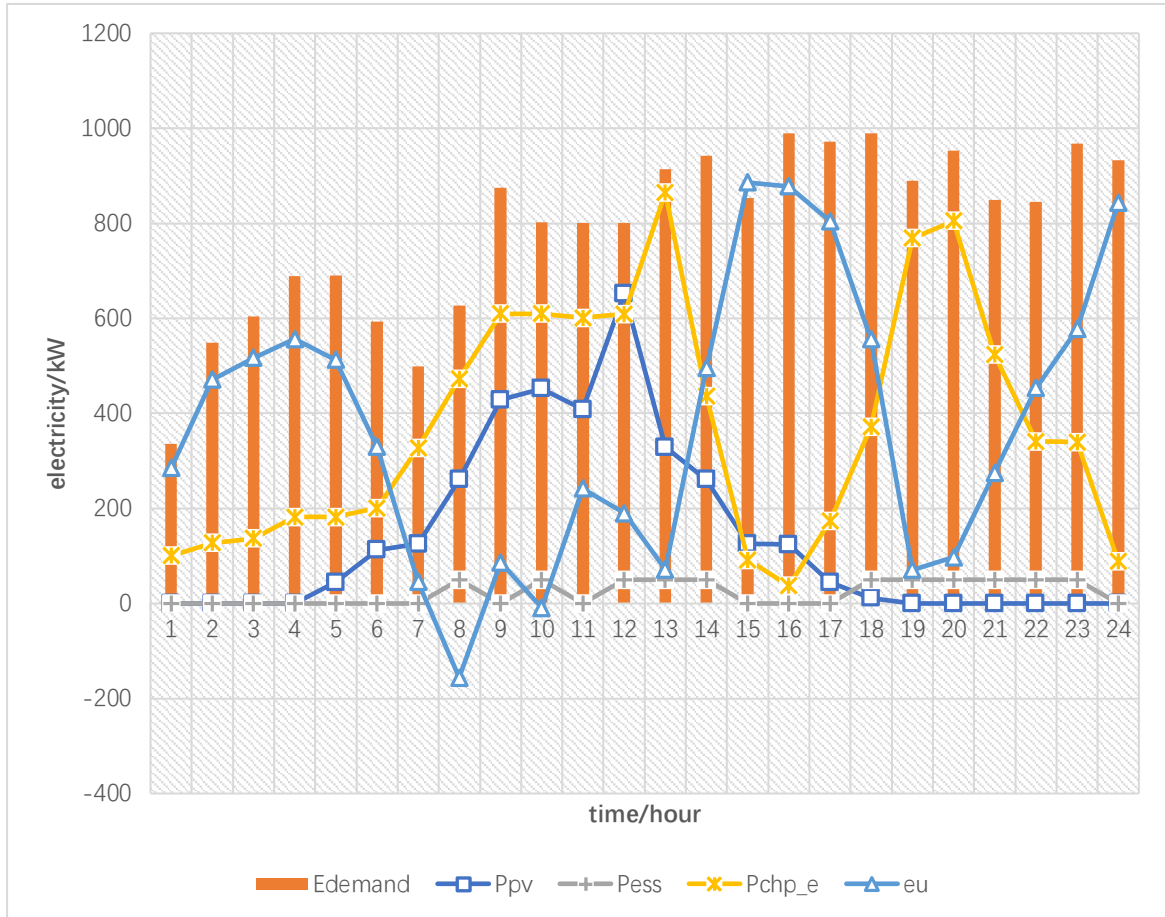

Fig.18. the Electricity Output of the EH With TE

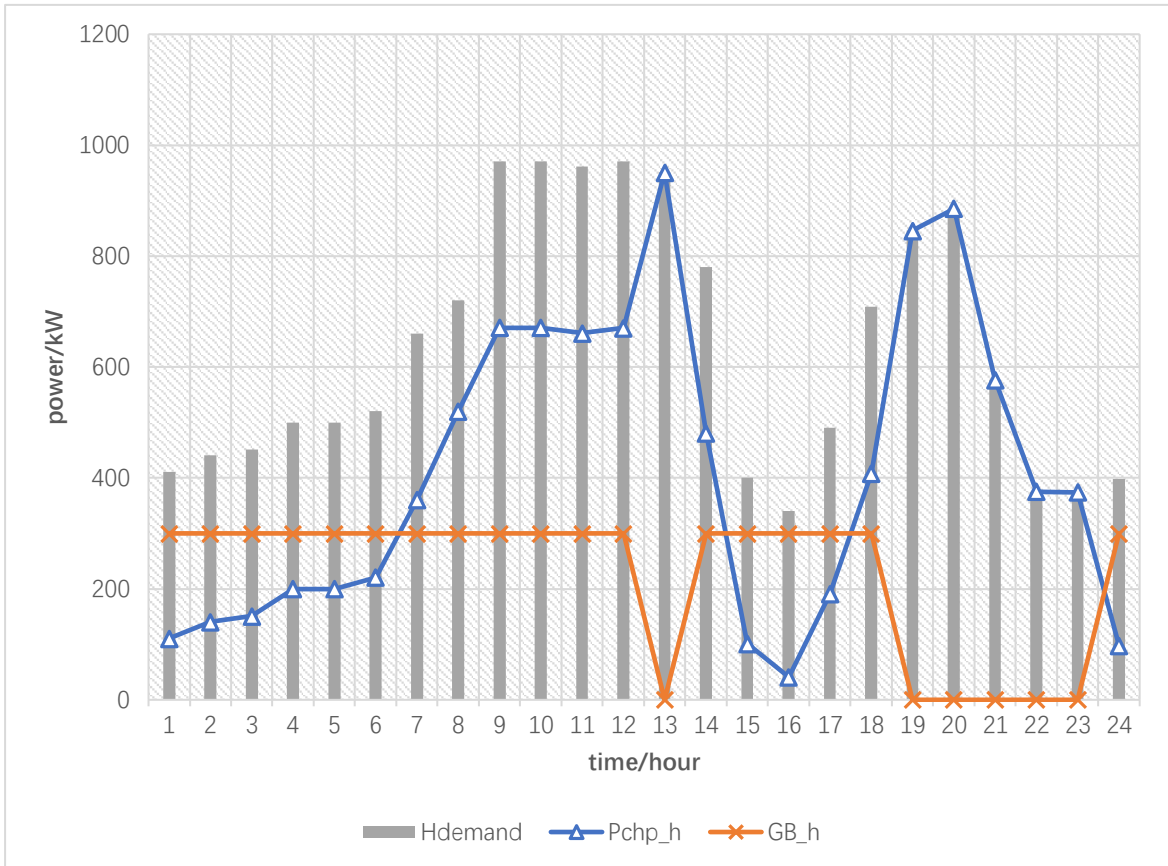

Fig.19. the Heating Output of the EH With TE

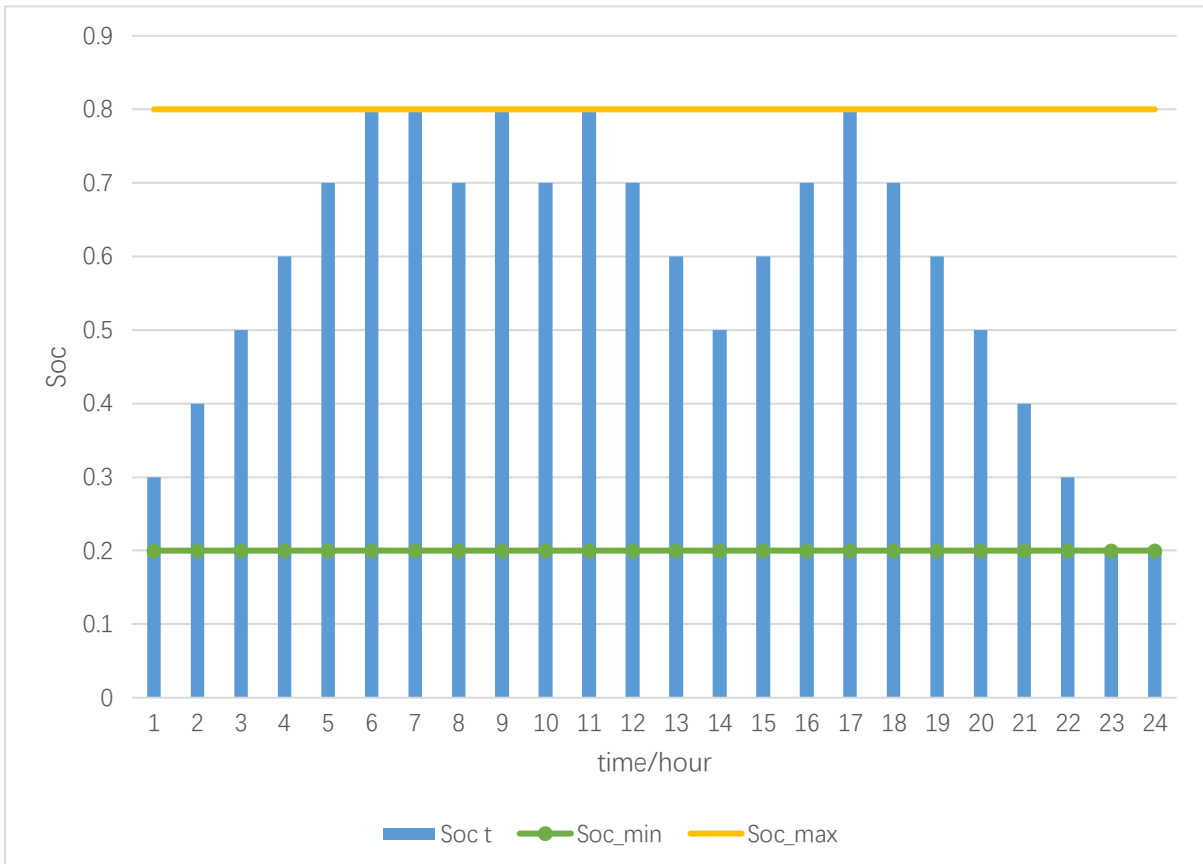

Fig.20. the State of Charge Level of the EH With TE

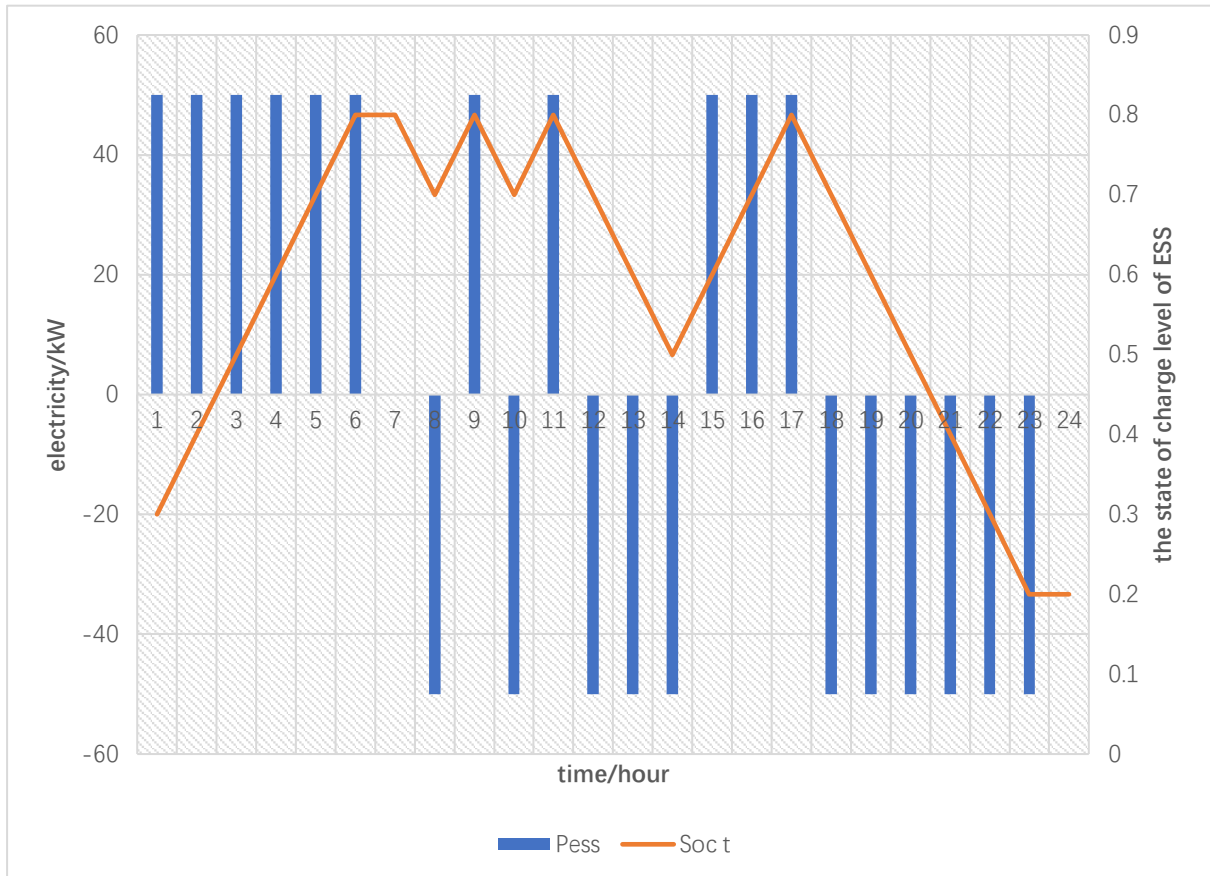

Fig.21. the Output of the HSS with TE

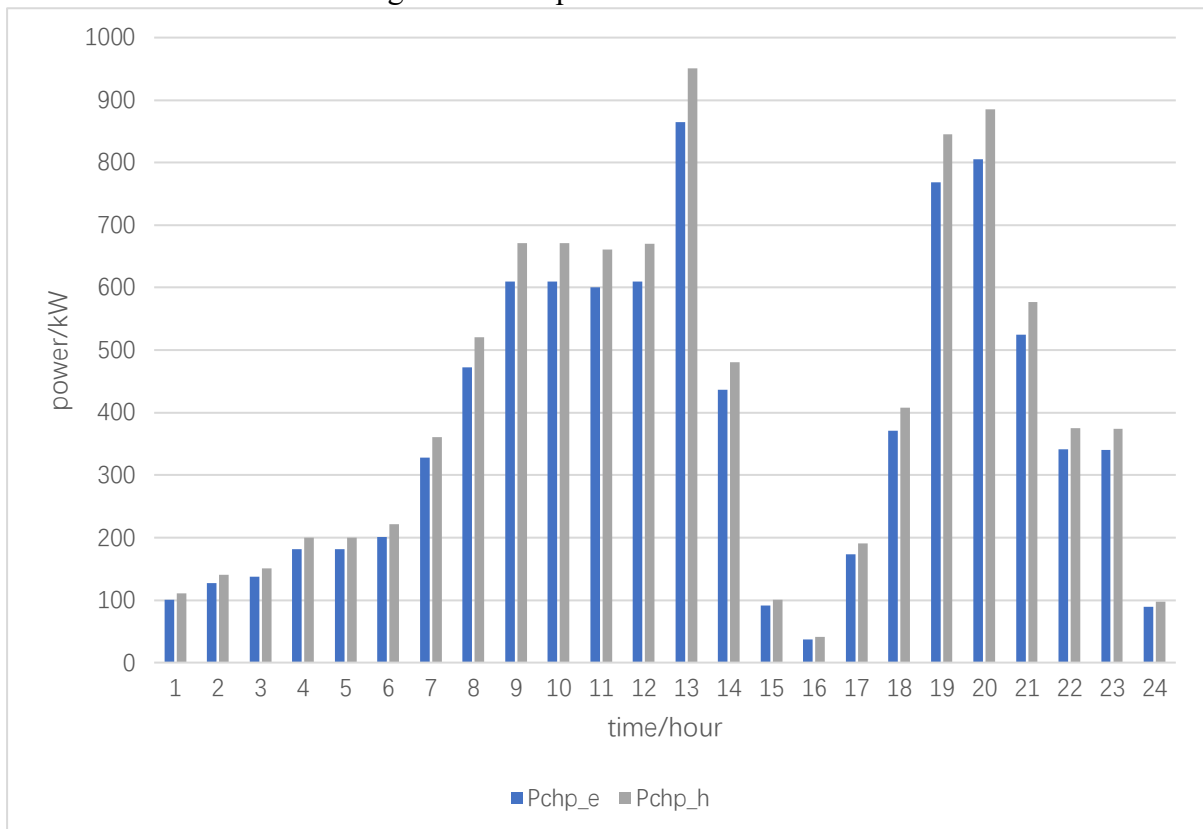

Fig.22. the Output of the CHP with TE

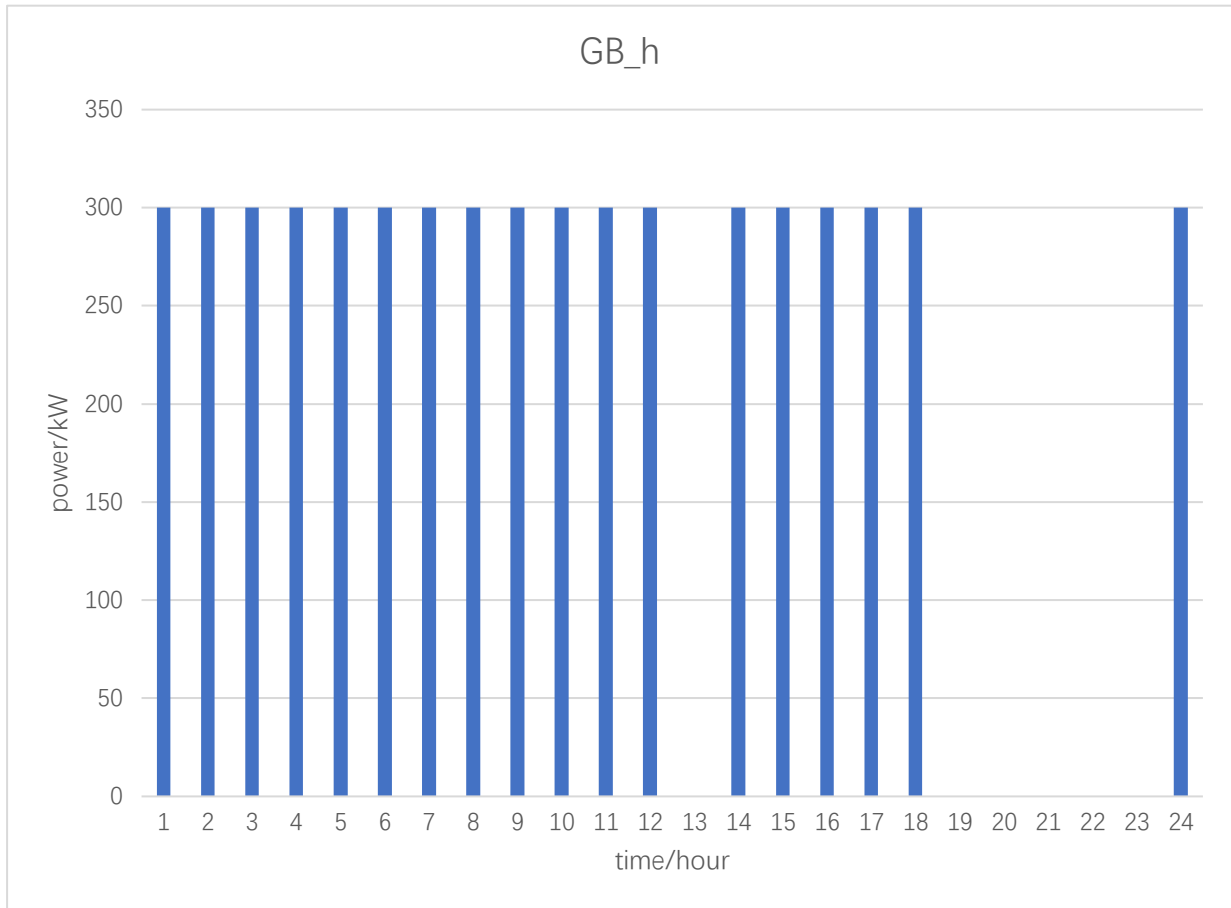

Fig.23. the Output of the GB with TE

As we can see from the Fig.18- Fig.23 and the Fig.12- Fig.17, we can see the optimization results of the EH with TE are totally the same to the those only considering the total cost of buying electricity and gas from the utility of the whole EH.

## 5.4 Comparative Analysis

After all simulation and discussion, we found the results of these two different methods are totally same, let's figure out why we got this. The differences between these two approaches are shown in the Table.3.

Table.3 the Optimization Objective Functions of Two Methods

Optimization dispatch based on the cost of the whole EH	Optimization dispatch based on the profits of prosumers and the cost of loads
$\min C = C_G + C_E$ $= \sum_{t=1}^{24} \left\{ k_G \right.$ $\left. * \left[ (1/L) * \left( \frac{P_{e_{chp}}^t}{\eta_{chp}} \right) + P_{GB}^t \right] \right\}$ $+ \sum_{t=1}^{24} k_e^t * P_{e_{utility}}^t$ $P_{e_{chp}}^t + P_{e_{utility}}^t + P_{e_{ess}}^t + P_{e_{pv}}^t = l_e^t$ $P_{h_{chp}}^t + P_{GB}^t = l_h^t$ $0 \leq P_{h_{chp}}^t \leq P_{h_{chp}}^{max}$ $0 \leq P_{e_{chp}}^t \leq P_{e_{chp}}^{max}$ $P_{e_{chp}}^t = \left( \frac{\sum_{i=1}^n l_{hi}^t}{\delta_{heat}} \right) * \frac{\eta_{chp}}{1 - \eta_{chp} - \eta_{loss}}$ $0 \leq P_{GB}^t \leq P_{GB}^{max}$ $-P_{e_{ess}}^{max} \leq P_{e_{ess}}^t \leq P_{e_{ess}}^{max}$ $0 \leq E_{store}^t \leq E_{store}^{max}$	$\min C = C_G + C_E$ $= \sum_{t=1}^{24} \left\{ k_G \right.$ $\left. * \left[ (1/L) * \left( \frac{P_{e_{chp}}^t}{\eta_{chp}} \right) + P_{GB}^t \right] \right\}$ $+ \sum_{t=1}^{24} k_e^t * P_{e_{utility}}^t$ $\max Profit_{CHP}$ $= \sum_{i=1}^{24} (price\_e^t * P_{e_{chp}}^t$ $+ price\_h^t * P_{h_{chp}}^t - k_G$ $* P_{gas\_chp}^t)$ $\max Profit_{GB} = \sum_{i=1}^{24} (price\_h^t * H_{GB\_out}^t$ $- k_G * P_{gas\_GB\_in}^t)$ $\max Profit_{ESS} = \sum_{i=1}^{24} price\_e^t * E_{ess}^t - k_E^t * E_{ess}^t$

As we can see from the Table.3, the main feature of the method with TE distinguishing it from another is it considers the loads and the prosumers in this EH as its interest body, but the former one takes the whole EH as its object to do the optimization.

For a EH, it includes three parts inside it, buying energy from the utility, transmit and convert energy of prosumers inside the EH, selling energy to the subjects in the demand side. This correlation can be entirely shown in Fig.24.

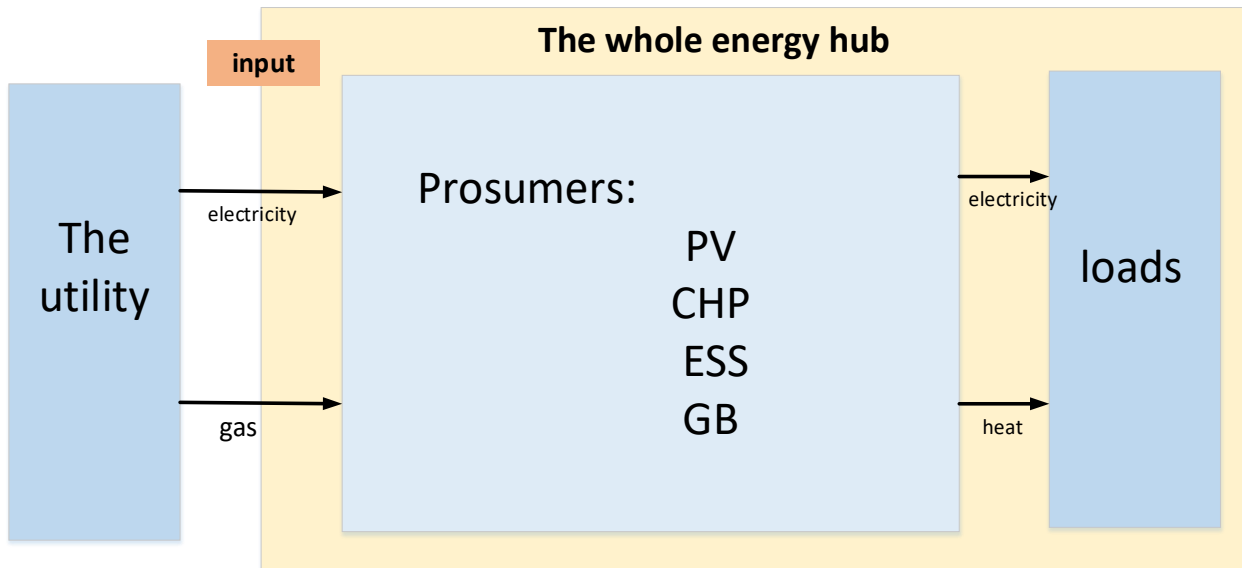

Fig.24. interest subjects in the EH

As is shown in Fig.24, the interest subjects in this model can be divided into two parts:

- 1) On behalf of the whole EH, the buying cost of energy from the utility is set as the optimization index of the hub manager.
- 2) The profits of the components inside the EH are taken into consideration, including the profits of prosumers and the cost at the load side. HM takes these as the target of the optimization dispatch.

These two methods above have different objective functions, though. They are actually same in some extent. Because of the energy conservation, both the input side and the output side are roughly determined by the load demand. No matter the input or the output is reduced, the other side will change with each other.

The total costs of the EH buying energy from the utility of these two methods are shown in Table.4.

Table.4. the total costs of the whole EH

	Optimization dispatch based on the cost of the whole EH	Optimization dispatch based on the profits of prosumers and the cost of loads
Cost/dollar	18486.32	18486.32

It is shown that the proposed decentralized algorithm can reach the global optimality of the system dispatch problem as the centralized optimization with perfect information. The optimality of the proposed decentralized algorithm is guaranteed. More importantly, the centralized optimization method implies that the HM has the full rights to directly determine the dispatch decisions of the local components in the system, which may not always be the case in practice. In the proposed decentralized algorithm based on the TE concept, the interest of the local components is considered, and direct control from the HM to the local components is not required. With respect to the centralized schemes using direct control, the dispatch decisions of the local components are based on the optimizations which maximize their own surplus in the proposed decentralized scheme based on TE. Further, inheriting the advantages from the TE mechanisms, the proposed decentralized scheme makes full use of the response potential of the local components considering their own interests, has a certain system reaction while raising no privacy issues. Thus, the proposed decentralized scheme is an effective and practical solution for the dispatch problem of EH.

## Chapter 6 Conclusion and Future work

### 6.1 Conclusion

Transactive energy framework for the multi-energy management in smart community is effective and economic based on the discussion above. Because of the intermittency of renewable energy sources and the instability of the load demand, we added the energy storage facility in the EH. We chose the price signal as the value in our EH to complete our transaction. The HM sends dynamical pricing variations of electricity and heat to the prosumers and load, then maximize the benefits of both parties in the exchange of information.

By using Karush–Kuhn–Tucker (KKT) condition and big M Method in the simulation, we transferred the bilevel problem into a single level mixed linear problem to solve it. The proposed hierarchical transactive energy management is feasible and efficient for the development of a power sharing architecture within a community where prosumers can be involved to make profits. The advantages of the proposed scheme would encourage the prosumers and load to develop a sustainable and stable community.

At the last part of this thesis, we compared the method using TE in the EH with the centralized method to minimize the cost of the whole EH, which proves the feasibility and effectiveness of this method.

### 6.2 Future Work

In our future work, we tend to add DSM with reward and punishment mechanisms into our transactive model, so that the participated users in the market could consciously and voluntarily adjust the load of their electrical and heating equipment to meet the reliability of power system,

dynamic optimization and balance, and systematic energy saving and emission reduction in response to price signals or incentive mechanism when there are risks powering consumption during peak hours or system safety and reliability.

## REFERENCES

- [1] M. Geidl, G. Koeppel, P. Favre-Perrod, B. Klockl, G. Andersson, K. Frohlich, "Energy hubs for the future," *IEEE Power and Energy Magazine*, Vol.5, no.1, pp.24-30, 2007.
- [2] Y. Wang, N. Zhang, C. Kang, D. S. Kirschen, J. Yang, and Q. Xia, "Standardized matrix modeling of multiple energy systems," *IEEE Trans.Smart Grid*, 2018, Early access.
- [3] T. Krause, G. Andersson, K. Fröhlich, and A. Vaccaro, "Multiple-energy carriers: modeling of production, delivery, and consumption," *Proc. IEEE*, vol. 99, no. 1, pp. 15–27, 2011.
- [4] X. Liu, H. Wu, "A control strategy and operation optimization of combined cooling heating and power system considering solar comprehensive utilization," *Automation of Electric System*, Vol.39, No.12, pp. 1-6, 2015.
- [5] Y. Yang, J. Yu, Y. Li, "Optimal load leveling dispatch of CCHP incorporating photovoltaic and storage," *Automation of Electric System*, Vol.41, No.6, pp. 6-12, 2017.
- [6] A. Ipakchi and F. Albuyeh, "Grid of the future," *IEEE Power & Energy Mag.*, vol. 7, no. 9, pp. 52-62, Mar. 2009.
- [7] T. Ha, Y Zhang, T. Hang. "Energy hub modeling to minimize residential energy costs considering solar energy and BESS," *Journal of Modern Power Systems and Clean Energy*, Vol.5, No.3, pp. 389-399, 2017.
- [8] Z. Yan, J. Liu, Z. Wei, "Investigation on multi-energy equivalent mode and transition benefit mode," *.Power System Technology*, Vol.40, No.6, pp. 1620-1626, 2016.
- [9] S. Bahrami, M. Toulabi, S. Ranjbar, M. Moeini-Aghtaie, and A. M. Ranjbar, "A decentralized energy management framework for energy hubs in dynamic pricing markets," *IEEE Trans. Smart Grid*, 2018, Early access.
- [10] X. Zhang, L. Che, M. Shahidehpour, A. S. Alabdulwahab, and A. Abusorrah, "Reliability-based optimal planning of electricity and natural gas interconnections for multiple energy hubs," *IEEE Trans. Smart Grid*, vol. 8, no. 4, pp. 1658–1667, 2017.
- [11] S. D. Manshadi and M. E. Khodayar, "Coordinated operation of electricity and natural gas systems: a convex relaxation approach," *IEEE Trans. Smart Grid*, 2018, Early access.
- [12] J. Qiu, Z. Y. Dong, J. H. Zhao, K. Meng, Y. Zheng, and D. J. Hill, "Low carbon oriented expansion planning of integrated gas and power systems," *IEEE Trans. Power Syst.*, vol. 30, no. 2, pp. 1035-1046, Mar. 2015.
- [13] X. Zhang, M. Shahidehpour, A. Alabdulwahab, and A. Abusorrah, "Optimal expansion planning

- of energy hub with multiple energy infrastructures," *IEEE Trans. Smart Grid*, vol. 6, no. 5, pp. 2302-2311, Sep. 2015.
- [14] M. Geidl, G. Koepfel, P. Favre-Perrod, B. Klockl, G. Andersson, and K. Frohlich, "Energy hubs for the future," *IEEE Power & Energy Mag.*, vol. 5, no. 1, pp. 24-30, Mar. 2007.
- [15] M. Geidl and G. Andersson, "Optimal power flow of multiple energy carriers," *IEEE Trans. Power Syst.*, vol. 22, no. 1, pp. 145-155, Feb. 2007.
- [16] M. Moeini-Aghtaie, A. Abbaspour, M. Fotuhi-Firuzabad, and E. Hajipour, "A decomposed solution to multiple-energy carriers optimal power flow," *IEEE Trans. Power Syst.*, vol. 29, no. 2, pp. 707-716, Mar. 2014.
- [17] Y. Wen, X. Qu, W. Li, X. Liu, and X. Ye, "Synergistic operation of electricity and natural gas networks via ADMM," *IEEE Trans. Smart Grid*, early access, 2017.
- [18] C. M. Correa-Posada and P. Sanchez-Martin, "Security-constrained optimal power and natural gas flow," *IEEE Trans. Power Syst.*, vol. 29, no. 4, pp. 1780-1787, Jul. 2014.
- [19] M. Qadrdan, J. Wu, N. Jenkins, and J. Ekanayake, "Operating strategies for a GB integrated gas and electricity network considering the uncertainty in wind power forecasts," *IEEE Trans. Sustain. Energy*, vol. 5, no. 1, pp. 128-138, Jan. 2014.
- [20] C. He, L. Wu, T. Liu, and M. Shahidehpour, "Robust co-optimization scheduling of electricity and natural gas systems via ADMM," *IEEE Trans. Sustain. Energy*, vol. 8, no. 2, pp. 658-670, Apr. 2017.
- [21] S. Clegg and P. Mancarella, "Integrated electrical and gas network flexibility assessment in low-carbon multi-energy systems," *IEEE Trans. Sustain. Energy*, vol. 7, no. 2, pp. 718-731, Apr. 2016.
- [22] Z. Qiao, Q. Guo, H. Sun, Z. Pan, Y. Liu, and W. Xiong, "An interval gas flow analysis in natural gas and electricity coupled networks considering the uncertainty of wind power," *Applied Energy*, vol. 201, pp. 343-353, Sep. 2017.
- [23] M. C. Bozchalui, S. A. Hashmi, H. Hassen, C. A. Canizares, and K. Bhattacharya, "Optimal operation of residential energy hubs in smart grid," *IEEE Trans. Smart Grid*, vol. 3, no. 4, pp. 1755-1766, Dec. 2012.
- [24] A. Anvari-Moghaddam, J. M. Guerrero, J. C. Vasquez, H. Monsef, and A. Rahimi-Kian, "Efficient energy management for a grid-tied residential microgrid," *IET Gener. Transm. Distrib.*, vol. 11, no. 11, pp. 2752-2761, Aug. 2017.
- [25] H. Karami, M. J. Sanjari, S. H. Hosseini, and G. B. Gharehpetian, "An optimal dispatch algorithm for managing residential distributed energy resources," *IEEE Trans. Smart Grid*, vol. 5, no. 5, pp. 2360-2367, Sep. 2014.

- [26] M. Rastegar, M. Fotuhi-Firuzabad, H. Zareipour, and M. Moeini-Aghtaie, "A probabilistic energy management scheme for renewable-based residential energy hubs," *IEEE Trans. Smart Grid*, vol. 8, no. 5, pp. 2217-2227, Sep. 2017.
- [27] H. Wu, A. Pratt, and S. Chakraborty, "Stochastic optimal scheduling of residential appliances with renewable energy sources," in *IEEE PES General Meeting*, Denver, CO, USA, Jul. 2015.
- [28] C. Shao, X. Wang, M. Shahidehpour, X. Wang, and B. Wang, "An MILPbased optimal power flow in multicarrier energy system," *IEEE Trans. Sustain. Energy*, vol. 8, no. 1, pp. 239-248, Jan. 2017.
- [29] X. Zhang, M. Shahidehpour, A. Alabdulwahab, and A. Abusorrah, "Hourly electricity demand response in the stochastic day-ahead scheduling of coordinated electricity and natural gas networks," *IEEE Trans. Power Syst.*, vol. 31, no. 1, pp. 592-601, Jan. 2016.
- [30] N. Good and P. Mancarella, "Flexibility in multi-energy communities with electrical and thermal storage: a stochastic, robust approach for multi-service demand response," *IEEE Trans. Smart Grid*, early access, 2017.
- [31] L. Ni, W. Liu, F. Wen, Y. Xue, Z. Dong, Y. Zheng, and R. Zhang, "Optimal operation of electricity, natural gas and heat systems considering integrated demand responses and diversified storage devices," *J. Mod. Power Syst. Clean Energy*, vol. 6, no. 3, pp. 423-437, May 2018.
- [32] I. G. Moghaddam, M. Saniei, and E. Mashhour, "A comprehensive model for self-scheduling an energy hub to supply cooling, heating and electrical demands of a building," *Energy*, vol. 94, pp. 157-170, 2016.
- [33] M. Majidi and K. Zare, "Integration of Smart Energy Hubs in Distribution Networks under Uncertainties and Demand Response Concept," *IEEE Trans. Power Syst.*, 2018, Early access.
- [34] R. Li, W. Wei, S. Mei, Q. Hu, and Q. Wu, "Participation of an Energy Hub in Electricity and Heat Distribution Markets: An MPEC Approach," *IEEE Trans. Smart Grid*, 2018, Early access.
- [35] St. John, J., "A How-to-Guide for Transactive Energy," *GreenTech Media*.2013.
- [36] GridWise Architecture Council, *GridWise TE Framework (Draft)*, October 2013.
- [37] Fang, X., S. Misra, G. Xue, D. Yang, 2012. *Smart Grid - The New and Improved Power Grid: A Survey*, *IEEE Communications Surveys & Tutorials*, Vol. 14, No. 4.
- [38] S. Katipamula, D.P. Chassin, D.D. Hatley R.G. Pratt, D.J. Hammerstrom, "Transactive Controls: Market-Based GridWise Controls for Building Systems," *Pacific Northwest National Laboratory*, 2006.
- [39] K. Kok, S. Widergren, "A Society of Devices: Integrating Intelligent Distributed Resources with

Transactive Energy,” IEEE Power and Energy Magazine, vol.14, no.3, pp.34-45,2016.

- [40] Y. Guo, M. Pan, Y. Fang, and P. Khargonekar, “Decentralized coordination of energy utilization for residential households in the smart grid,” IEEE Transactions on Smart Grid, vol. 4, no. 3, pp. 1341–1350,2013.
- [41] L. Jiang and S. Low, “Multi-period optimal energy procurement and demand response in smart grid with uncertain supply,” in 2011 50th IEEE Conference on Decision and Control and European Control Conference (CDC-ECC), 2011, pp. 4348–4353.
- [42] Y. Liu, C. Yuen, N. Ul Hassan, S. Huang, R. Yu, and S. Xie, “Electricity cost minimization for a microgrid with distributed energy resource under different information availability,” IEEE Transactions on Industrial Electronics, vol. 62, no. 4, pp. 2571–2583, 2015.
- [43] K. Worthmann, C. Kellett, P. Braun, L. Grune, and S. Weller, “Distributed and decentralized control of residential energy systems incorporating battery storage,” IEEE Transactions on Smart Grid, vol. 6, no. 4, pp. 1914–1923, 2015.
- [44] A. Werth, N. Kitamura, I. Matsumoto, and K. Tanaka, “Evaluation of centralized and distributed microgrid topologies and comparison to open energy systems (OES),” in 2015 IEEE 15th International Conference on Environment and Electrical Engineering (EEEIC), pp. 492–497,2015.
- [45] S. Mitra, L. Sun, and I. E. Grossmann, “Optimal scheduling of industrial combined heat and power plants under time-sensitive electricity prices,” Energy, vol. 54, no. 2, pp. 194-211, 2013.
- [46] M. Houwing, R. R. Negenborn, and B. De Schutter, “Demand Response with Micro-CHP Systems,” Proc. IEEE, vol. 99, no. 1, pp. 200-213, 2011.
- [47] J. Chen, X. Yang, L. Zhu, and M. Zhang, “Genetic algorithm based economic operation optimization of a combined heat and power microgrid,” Power Sys. Prot. Control., vol. 41, no. 8, pp. 7-15, 2013 (in Chinese).