

LARGE SCALE GEOMETRY OF SURFACES IN 3-MANIFOLDS

by

Hoang Thanh Nguyen

A Dissertation Submitted in  
Partial Fulfillment of the  
Requirements for the Degree of

Doctor of Philosophy  
in Mathematics

at

The University of Wisconsin-Milwaukee

May 2019

# ABSTRACT

## LARGE SCALE GEOMETRY OF SURFACES IN 3-MANIFOLDS

by

Hoang Thanh Nguyen

The University of Wisconsin-Milwaukee, 2019  
Under the Supervision of Professor Christopher Hruska

A compact, orientable, irreducible 3-manifold  $M$  with empty or toroidal boundary is called geometric if its interior admits a geometric structure in the sense of Thurston. The manifold  $M$  is called non-geometric if it is not geometric. Coarse geometry of an immersed surface in a geometric 3-manifold is relatively well-understood by previous work of Hass, Bonahon-Thurston. In this dissertation, we study the coarse geometry of an immersed surface in a non-geometric 3-manifold.

The first chapter of this dissertation is a joint work with my advisor, Chris Hruska. We answer a question of Daniel Wise about distortion of a horizontal surface subgroup in a graph manifold. We show that the surface subgroup is quadratically distorted in the fundamental group of the graph manifold whenever the surface is virtually embedded (i.e., separable) and is exponentially distorted when the surface is not virtually embedded.

The second chapter of this dissertation generalizes the previous work of the author and Hruska to surface subgroups in non-geometric 3-manifold groups. We show that the only possibility of the distortion is linear, quadratic, exponential, and double exponential. We also establish a strong connection between the distortion and the separability of surface subgroups in non-geometric 3-manifold groups.

The final chapter of the dissertation makes a progress in understanding the structure of the group of quasi-isometries of a closed graph manifold which is mysterious.

## DEDICATION

To my parents, my wife and my son, they are part of the success.

# TABLE OF CONTENTS

<b>Table of Contents</b>	<b>iv</b>
<b>List of Figures</b>	<b>vi</b>
<b>Introduction</b>	<b>1</b>
<b>1 Distortion of surfaces in graph manifolds</b>	<b>3</b>
1.1 Introduction . . . . .	3
1.1.1 Connections to previous work . . . . .	6
1.1.2 Overview . . . . .	7
1.2 Preliminaries . . . . .	8
1.3 Curves in hyperbolic surfaces . . . . .	11
1.4 Graph manifolds and horizontal surfaces . . . . .	13
1.5 A lower bound for distortion . . . . .	19
1.6 Upper Bound of Distortion . . . . .	27
1.7 Fiber surfaces have quadratic distortion . . . . .	38
<b>2 Distortion of surfaces in 3-manifolds</b>	<b>41</b>
2.1 Introduction . . . . .	41
2.1.1 Overview . . . . .	46
2.2 Preliminaries . . . . .	47
2.3 Surfaces in non-geometric 3-manifolds . . . . .	48
2.3.1 Metrics on non-geometric 3-manifolds . . . . .	55

2.4	Distortion of surfaces is determined by the almost fiber part . . . . .	56
2.5	Distortion of clean almost fiber surfaces in mixed manifolds . . . . .	66
2.5.1	Upper bound of the distortion . . . . .	67
2.5.2	Lower bound of the distortion . . . . .	78
2.6	Distortion of surfaces in non-geometric 3-manifolds . . . . .	89
<b>3</b>	<b>Quasi-isometries of pairs: surfaces in graph manifolds</b>	<b>91</b>
3.1	Introduction . . . . .	91
3.2	Quasi-isometry of the pairs of spaces . . . . .	94
3.3	Graph manifolds and horizontal surfaces . . . . .	98
3.4	Constructing horizontal surfaces . . . . .	100
3.5	Proof of the main Theorem . . . . .	106
3.6	Appendix . . . . .	109
3.6.1	k-volume distortion . . . . .	109
3.6.2	Relative divergence . . . . .	110
	<b>Bibliography</b>	<b>113</b>
	<b>Curriculum Vitae</b>	<b>118</b>

# LIST OF FIGURES

1.1	On the left, the piecewise geodesic $\tilde{\sigma}_n$ is the spiral-shaped path running around the outside of the diagram. On the right is a magnified portion of the left-hand picture showing more detail. . . . .	23
1.2	The outer path represents the piecewise geodesic $\tilde{\rho}_n$ . . . . .	23
2.1	The upper picture illustrates the two end points of each path $\beta_{i_j}$ are within a $R$ -neighborhood of $\alpha_{i_j} \subset \gamma'$ . We add a geodesic in the almost fiber part of $\tilde{S}$ connecting $\beta_{i_j}(1)$ to $\beta_{i_{j+1}}(0)$ . The lower picture illustrates the point $v_{i_j}$ (resp. $u_{i_j}$ ) is within $R$ -distance from $\beta_{i_j}(0)$ (resp. $\beta_{i_j}(1)$ ). The path $\gamma'_s$ is the subpath of $\gamma'$ that connects $v_{i_j}$ to $u_{i_{j+1}}$ . . . . .	63
2.2	The picture illustrates the slices that $x_j, y_j, z_j$ belong to . . . . .	82
3.1	The left down arrow illustrates the horizontal surface $\overleftarrow{g}: \overleftarrow{B} \rightarrow \overleftarrow{F} \times S^1$ and the right down arrow illustrates the horizontal surface $\overrightarrow{g}: \overrightarrow{B} \rightarrow \overrightarrow{F} \times S^1$ in Lemma 3.4.1. The simple graph manifold $N'$ is obtained from $\overleftarrow{F} \times S^1$ to $\overrightarrow{F} \times S^1$ by gluing the boundary torus $\overleftarrow{\alpha} \times S^1$ of $\overleftarrow{F} \times S^1$ to the boundary torus $\overrightarrow{\alpha} \times S^1$ of $\overrightarrow{F} \times S^1$ via the gluing matrix $J$ . We paste $\overleftarrow{g}$ and $\overrightarrow{g}$ to form the horizontal surface $g: B_n \rightarrow N'$ . The oriented curve $\gamma_n$ in the surface $B_n$ is shown in the Figure. . . . .	103

## ACKNOWLEDGMENTS

I consider myself very fortunate for having a great doctoral advisor, Prof. Chris Hruska. I deeply appreciate him for being very generous for his time with me during my time as his student. I would like to thank him for his helpful guidance, encouragement and invaluable advice.

I would like to thank professors in my Ph.d committee members Hruska, Okun, Suzanne, Guilbault, Healy for for their support and for their time spent to review my dissertation. I also would like to thank Prof. Craig Guilbault, Prof. Ric Ancel, and Prof. Boris Okun and all the students in the UWM Topology group for their comments and suggestions during my seminar talks at UWM.

In the process of submitting this research to journals, I have got many insightful comments from multiple referees, so I would like to thank the referees. I also want to thank Daniel Woodhouse, Hung Cong Tran, Dan Margalit, Water Neumann, Yi Liu, Hongbin Sun for their correspondences that contribute to my dissertation. Thanks to Prayagdeep Parija for being very generous with his time in correcting my English in this dissertation as well as my papers.

Thanks to the UWM departement of mathematical sciences for being a great place to do research.

# Introduction

My primary area of research is geometric group theory. An important idea in geometric group theory is to consider a finitely generated group as a geometric object by equipping the group with a word length metric. Gromov has been successful in promoting this idea to study finitely generated groups. A finitely generated group  $G$  can be considered as a metric space when we equip  $G$  with the word metric from a finite generating set.

If  $H \leq G$ , we may consider both  $H$  and  $G$  to be geometric objects. However the inclusion  $H \hookrightarrow G$  may not respect this geometry. A function that measures the changes between these two metrics is called *distortion*.

I am especially interested in the distortion of surface groups in 3-manifold groups. Distortion of a surface subgroup in a geometric 3-manifold group is relatively understood by the work of Hass and Bonahon-Thurston. However the distortion of a surface subgroup in a non-geometric manifold group is unknown before the projects in this dissertation. In this dissertation, a complete computation to the distortion of surface groups in non-geometric 3-manifold groups is provided. Moreover, A strong connection between subgroup distortion and subgroup separability is given (see Chapter 1 and Chapter 2). In addition to subgroup distortion, I also make a progress in understanding the structure of the group of quasi-isometries of a closed graph manifold which is completely mysterious (see Chapter 3).

The material in Chapter 1 is a joint work with Chris Hruska that was published, in a slightly different form, in Algebraic & Geometric Topology in Volume 19, issue 1 (2019), published by Mathematical Sciences Publishers. The material in Chapter 3 has been accepted

for publication in International Journal of Algebra and Computation.

# Chapter 1

## Distortion of surfaces in graph manifolds

### 1.1 Introduction

In the study of 3-manifolds, much attention has focused on the distinction between surfaces that lift to an embedding in a finite cover and those that do not. A  $\pi_1$ -injective immersion  $S \looparrowright N$  of a surface  $S$  into a 3-manifold  $N$  is a *virtual embedding* if (after applying a homotopy) the immersion lifts to an embedding of  $S$  into a finite cover of  $N$ . Due to work of Scott and Przytycki–Wise [Sco78, PW14a], virtual embedding is equivalent to separability of the surface subgroup  $\pi_1(S)$  in  $\pi_1(N)$ .

A major part of the solution of the virtual Haken conjecture is Wise and Agol’s theorem that every immersed surface in a finite volume complete hyperbolic 3-manifold is virtually embedded [Wis12b, Ago13]. In contrast, Rubinstein–Wang [RW98] constructed non-virtually embedded surfaces  $g: S \looparrowright N$  in many 3-dimensional graph manifolds  $N$ . The examples of Rubinstein–Wang are *horizontal* in the sense that in each Seifert component  $M$  of  $N$ , the intersection  $g(S) \cap M$  is transverse to the Seifert fibration. Furthermore, they introduced a combinatorial invariant of horizontal surfaces called dilation, which they use to completely characterize which horizontal surfaces are virtually embedded.

If  $H \leq G$  are groups with finite generating sets  $\mathcal{S}$  and  $\mathcal{T}$ , the *distortion* of  $H$  in  $G$  is

given by

$$\Delta_H^G(n) = \max\{ |h|_{\mathcal{T}} \mid h \in H \text{ and } |h|_{\mathcal{S}} \leq n \}.$$

Distortion does not depend on the choice of finite generating sets  $\mathcal{S}$  and  $\mathcal{T}$  (up to a natural equivalence relation). The purpose of this article is to address the following question of Dani Wise:

**Question 1.1.1.** Given a 3–dimensional graph manifold  $N$ , which surfaces in  $N$  have non-trivial distortion?

Question 1.1.1 arises naturally in the study of cubulations of 3–manifold groups. The typical strategy for constructing an action of the fundamental group on a CAT(0) cube complex is to find a suitable collection of immersed surfaces and then to consider the CAT(0) cube complex dual to that collection of surfaces (see for instance [Wis12a]).

Whenever a group  $G$  acts properly and cocompactly on a CAT(0) cube complex  $X$ , the stabilizer of each hyperplane must be an undistorted subgroup of  $G$ , since hyperplanes are convex. Hagen–Przytycki [HP15] show that chargeless graph manifolds do act cocompactly on CAT(0) cube complexes. It is clear from their construction that many graph manifolds contain undistorted surface subgroups.

However the situation for horizontal surfaces turns out to be quite different. Our main result states that horizontal surfaces in graph manifolds always have a nontrivial distortion, and this distortion is directly related to virtual embedding in the following sense:

**Theorem 1.1.2.** *Let  $S \looparrowright N$  be a horizontal surface properly immersed in a graph manifold  $N$ . The distortion of  $\pi_1(S)$  in  $\pi_1(N)$  is quadratic if  $S$  is virtually embedded, and exponential if  $S$  is not virtually embedded.*

The main tool used in the proof of this theorem is a simple geometric interpretation of Rubinstein–Wang’s dilation in terms of slopes of lines in the JSJ planes of the universal cover.

We note that, throughout this paper, the term “graph manifold” specifically excludes two trivial cases: Seifert manifolds and Sol manifolds. By Proposition 1.6.7 horizontal surfaces in Seifert manifolds are always undistorted. Distortion of surfaces in Sol manifolds is not addressed in this article.

Although Theorem 1.1.2 deals only with horizontal surfaces in graph manifolds, understanding these is the key to a general understanding of all  $\pi_1$ -injective surfaces in nongeometric 3-manifolds. The nongeometric 3-manifolds include both graph manifolds and also “mixed” type 3-manifolds, those whose JSJ decomposition contains at least one hyperbolic component and at least one JSJ torus.

Recently Yi Liu has used Rubinstein–Wang’s work on virtual embedding of horizontal surfaces in graph manifolds as the foundation for a study of virtual embedding of arbitrary surfaces in nongeometric 3-manifolds [Liu17]. Similarly, in a forthcoming article, the second author uses Theorem 1.1.2 as the foundation for a study of distortion of arbitrary surface subgroups in fundamental groups of nongeometric 3-manifolds [Ngu].

As mentioned above, Hagen–Przytycki [HP15] have shown that chargeless graph manifolds act cocompactly on CAT(0) cube complexes. The cubulation they construct is dual to a family of properly immersed surfaces, none of which is entirely horizontal. More precisely a key property of these surfaces is that they never contain two adjacent horizontal pieces.

The following corollary shows that in order to obtain a proper, cocompact cubulation (using any possible subgroups, not necessarily just surface subgroups) all surface subgroups must be of the type used by Hagen–Przytycki. The corollary follows from combining Theorem 1.1.2 with [Ngu].

**Corollary 1.1.3.** *Let  $G$  be the fundamental group of a graph manifold. Let  $\{H_1, \dots, H_k\}$  be a collection of codimension-1 subgroups of  $G$ . Let  $X$  be the corresponding dual CAT(0) cube complex. If at least one  $H_i$  is the fundamental group of a surface containing two adjacent horizontal pieces, then the action of  $G$  on  $X$  is not proper and cocompact.*

After seeing an early version of this paper, Hung Cong Tran discovered an alternate proof

of the quadratic distortion of certain horizontal surfaces whose fundamental groups can also be regarded as Bestvina–Brady kernels. This observation is part of a broader study by Tran of the distortion of Bestvina–Brady kernels in right-angled Artin groups [Tra17].

### 1.1.1 Connections to previous work

In [Woo16], Woodhouse exploited strong parallels between graph manifolds and tubular spaces to study actions of tubular groups on CAT(0) cube complexes. In the tubular setting, immersed hyperplanes play the role of immersed surfaces in graph manifolds. Woodhouse extended the Rubinstein–Wang theory of dilation and found a connection between dilation and distortion. In particular, he proves that if an immersed hyperplane in a tubular group has nontrivial dilation then its distortion is at least quadratic. Inspired by Woodhouse’s work, we use analogous techniques in the cleaner geometric setting of graph manifolds to obtain Theorem 1.1.2.

We remark that the main proof of Theorem 1.1.2 in Sections 1.5 and 1.6 includes both virtually embedded and non-virtually embedded surfaces in a unified treatment that prominently uses a simple geometric interpretation of dilation in terms of “slopes of lines” in the Euclidean geometry of JSJ planes. This interpretation was inspired by Woodhouse’s earlier work on tubular groups. It seems likely that the main proofs here could be translated back to the tubular setting, where they may lead to new advances in that setting as well.

However there is an alternate (shorter) proof of the quadratic distortion of virtually embedded horizontal surfaces using the following result, which combines work of Gersten and Kapovich–Leeb. This alternate approach, while more direct, does not give any information about the structure of non-virtually embedded surfaces.

**Theorem 1.1.4** (Gersten, Kapovich–Leeb). *Let  $N$  be a graph manifold that fibers over the circle with fiber surface  $S$ . Then  $\pi_1(S)$  is quadratically distorted in  $\pi_1(N)$ .*

Kapovich–Leeb implicitly use the quadratic upper bound (without stating it explicitly) in [KL98], where they attribute it to Gersten [Ger94]. The quadratic lower bound also follows

easily from results of Gersten and Kapovich–Leeb [Ger94, KL98], but was not specifically mentioned by them. The discussion of Theorem 1.1.4 in [KL98] and its precise derivation from [Ger94] is brief and was not the main purpose of either article. For the benefit of the reader we have included a more detailed exposition of Kapovich–Leeb’s elegant proof of Theorem 1.1.4 in Section 1.7, which relies on Thurston’s geometric classification of 3–manifolds that fiber over the circle.

The virtually embedded case of Theorem 1.1.2 can be derived as a corollary of Theorem 1.1.4 as follows. If a horizontal surface  $g: S \looparrowright N$  is virtually embedded then there exist finite covers  $\hat{S} \rightarrow S$  and  $\hat{N} \rightarrow N$  such that  $\hat{N}$  is an  $\hat{S}$ –bundle over  $S^1$  (see for instance [WY97]). By Theorem 1.1.4, the distortion of  $\pi_1(\hat{S})$  in  $\pi_1(\hat{N})$  is quadratic. Distortion is unchanged when passing to subgroups of finite index, so the distortion of  $\pi_1(S)$  in  $\pi_1(N)$  is also quadratic.

## 1.1.2 Overview

In Section 1.2 we review some concepts in geometric group theory. In Section 1.3 we give several lemmas about curves on hyperbolic surfaces that will be used in Section 1.5. Section 1.4 is a review background about graph manifolds and horizontal surfaces. A convenient metric on a graph manifold that will use in this paper will be discussed.

In Section 1.5 we prove the distortion of a horizontal surface in a graph manifold is at least quadratic. We also show that if the horizontal surface is not virtually embedded then the distortion is at least exponential. The strategy in this proof was inspired by the work of Woodhouse (see Section 6 in [Woo16]). In Section 1.6 we prove that distortion of a horizontal surface in a graph manifold is at most exponential. Furthermore, if the horizontal surface is virtually embedded then the distortion is at most quadratic.

Section 1.7 contains a detailed exposition of the proof of Theorem 1.1.4.

## 1.2 Preliminaries

In this section, we review some concepts in geometric group theory: quasi-isometry, distortion of a subgroup and the notions of domination and equivalence.

**Definition 1.2.1.** Let  $(X, d)$  be a metric space. A path  $\gamma: [a, b] \rightarrow X$  is a *geodesic* if  $d(\gamma(s), \gamma(t)) = |s - t|$  for all  $s, t \in [a, b]$ . A simple loop  $f: S^1 \rightarrow X$  is a *geodesic loop* if  $f$  is an isometric embedding with respect to some length metric on  $S^1$ .

**Definition 1.2.2** (quasi-isometry). Let  $(X_1, d_1)$  and  $(X_2, d_2)$  be metric spaces. A (not necessarily continuous) map  $f: X_1 \rightarrow X_2$  is an  $(L, C)$ -*quasi-isometric embedding* if there exist constants  $L \geq 1$  and  $C \geq 0$  such that for all  $x, y \in X_1$  we have

$$\frac{1}{L} d_1(x, y) - C \leq d_2(f(x), f(y)) \leq L d_1(x, y) + C.$$

If, in addition, there exists a constant  $D \geq 0$  such that every point of  $X_2$  lies in the  $D$ -neighborhood of the image of  $f$ , then  $f$  is an  $(L, C)$ -*quasi-isometry*. When such a map exists,  $X_1$  and  $X_2$  are *quasi-isometric*.

Let  $(X, d)$  be a metric space, and  $\gamma$  a path in  $X$ . We denote the length of  $\gamma$  by  $|\gamma|$ .

**Definition 1.2.3** (quasigeodesic). Let  $\gamma$  be a path in a metric space  $(X, d)$ . It is called  $(L, C)$ -*quasigeodesic* with respect to constants  $L \geq 1$  and  $C \geq 0$  if  $|\gamma_{[x,y]}| \leq L d(x, y) + C$  for all  $x, y \in \gamma$ . A *quasigeodesic* is a path that is  $(L, C)$ -quasigeodesic for some  $L$  and  $C$ .

**Definition 1.2.4.** A geodesic space  $(X, d)$  is  $\delta$ -*hyperbolic* if every geodesic triangle with vertices in  $X$  is  $\delta$ -*thin* in the sense that each side lies in the  $\delta$ -neighborhood of the union of the other two sides.

**Definition 1.2.5** (deviation). Let  $(X, d)$  be a geodesic space and  $c \geq 0$  be a fixed number. Consider a pair of geodesic segments  $[x, y]$  and  $[z, t]$  such that  $d(y, z) \leq c$ . The  $c$ -*deviation*

of  $[x, y]$  and  $[z, t]$ , denoted  $\text{dev}_c([x, y], [z, t])$ , is the quantity

$$\sup\{\max\{d(u, y), d(v, z)\} \mid u \in [x, y], v \in [z, t], d(u, v) \leq c\}.$$

The following theorem gives a criterion for determining that a piecewise geodesic in a  $\delta$ -hyperbolic space is a quasigeodesic. The proof, which is very similar to the proof of Lemma 19 of [GH90, Chapter 5], is left as an exercise to the reader.

**Theorem 1.2.6.** *Let  $(X, d)$  be a  $\delta$ -hyperbolic space. For any  $\kappa \geq 0$  and  $D \geq 0$ , there exist constants  $L = L(\delta, \kappa, D)$ , and  $C = C(\delta, \kappa, D)$  such that the following holds: Suppose a piecewise geodesic*

$$c = [x_1, x_2] \cup [x_2, x_3] \cup \cdots \cup [x_{2m-1}, x_{2m}]$$

satisfies

1.  $d(x_{2i}, x_{2i+1}) \leq \kappa$
2.  $d(x_{2i-1}, x_{2i}) \geq 11\kappa + 25\delta + 2D$ , and
3.  $\text{dev}_Q([x_{2i-1}, x_{2i}], [x_{2i+1}, x_{2i+2}]) \leq D$ , where  $Q = 4\delta + \kappa$ .

Then  $c$  is an  $(L, C)$ -quasigeodesic. □

**Definition 1.2.7.** Let  $f, g$  be functions from positive reals to positive reals. The function  $f$  is *dominated* by  $g$ , denoted  $f \preceq g$ , if there are positive constants  $A, B, C, D$  and  $E$  such that

$$f(x) \leq Ag(Bx + C) + Dx + E \quad \text{for all } x.$$

The functions  $f$  and  $g$  are *equivalent*, denoted  $f \sim g$ , if  $f \preceq g$  and  $g \preceq f$ .

The relation  $\preceq$  is an equivalence relation. Polynomial functions with degree at least one are equivalent if and only if they have the same degree. Furthermore, all exponential functions are equivalent.

**Definition 1.2.8** (Subgroup distortion). Let  $H \leq G$  be a pair of groups with finite generating sets  $\mathcal{T}$  and  $\mathcal{S}$  respectively. The *distortion* of  $(H, \mathcal{T})$  in  $(G, \mathcal{S})$  is the function

$$\Delta_H^G(n) = \max\{ |h|_{\mathcal{T}} \mid h \in H \text{ and } |h|_{\mathcal{S}} \leq n \}$$

Up to equivalence, the function  $\Delta_H^G$  does not depend on the choice of finite generating sets  $\mathcal{S}$  and  $\mathcal{A}$ .

Let  $H \leq G$  be a pair of finitely generated groups. We say that the distortion  $\Delta_H^G$  is *at least quadratic* [*exponential*] if it dominates a quadratic polynomial [exponential function]. The distortion  $\Delta_H^G$  is *at most quadratic* [*exponential*] if it is dominated by a quadratic polynomial [exponential function].

The following proposition is routine, and we leave the proof as an exercise for the reader.

**Proposition 1.2.9.** *Let  $G, H, K$  be finitely generated groups with  $K \leq H \leq G$ .*

1. *If  $H$  is a finite index subgroup of  $G$  then  $\Delta_K^H \sim \Delta_K^G$ .*
2. *If  $K$  is a finite index subgroup of  $H$  then  $\Delta_K^G \sim \Delta_H^G$ . □*

It is well known that a group acting properly, cocompactly, and isometrically on a geodesic space is quasi-isometric to the space. The following corollary of this fact allows us to compute distortion using the geometries of spaces in place of word metrics.

**Corollary 1.2.10.** *Let  $X$  and  $Y$  be compact geodesic spaces, and let  $g: (Y, y_0) \rightarrow (X, x_0)$  be  $\pi_1$ -injective. We lift the metrics on  $X$  and  $Y$  to geodesic metrics on the universal covers  $\tilde{X}$  and  $\tilde{Y}$  respectively. Let  $G = \pi_1(X, x_0)$  and  $H = g_*(\pi_1(Y, y_0))$ . Then the distortion  $\Delta_H^G$  is equivalent to the function*

$$f(n) = \max\{ d_{\tilde{Y}}(\tilde{y}_0, h(\tilde{y}_0)) \mid h \in H \text{ and } d_{\tilde{X}}(\tilde{x}_0, h(\tilde{x}_0)) \leq n \}.$$

### 1.3 Curves in hyperbolic surfaces

In this section, we will give some results about curves on surfaces that will play an essential role in the proof of Theorem 1.5.1.

**Definition 1.3.1** (Multicurves). A closed curve in a surface  $S$  is *essential* if it is not freely homotopic to a point or a boundary component. A *multicurve* in  $S$  is a finite collection of disjoint, essential simple closed curves such that no two are freely homotopic. If  $S$  has a metric, a multicurve is *geodesic* if each member of the family is a geodesic loop.

**Lemma 1.3.2.** *Let  $S$  be a compact surface with negative Euler characteristic. Let  $\mathcal{C}$  be a multicurve in  $S$ . Let  $\mathcal{L}$  be the family of lines that are lifts of loops of  $\mathcal{C}$  or boundary loops of  $S$ . Equip  $S$  with any length metric  $d_S$ . Let  $d$  be the induced metric on the universal cover  $\tilde{S}$ . For any  $r > 0$  there exists  $D = D(r) < \infty$  such that for any two disjoint lines  $\ell_1$  and  $\ell_2$  of  $\mathcal{L}$  we have*

$$\text{diam}(\mathcal{N}_r(\ell_1) \cap \mathcal{N}_r(\ell_2)) \leq D$$

*Proof.* Since  $H = \pi_1(S)$  acts cocompactly on the universal cover  $\tilde{S}$ , there exists a closed ball  $\overline{B}(x_0, R)$  whose  $H$ -translates cover  $\tilde{S}$ . Note that  $\mathcal{L}$  is locally finite in the sense that only finitely many lines of  $\mathcal{L}$  intersect the closed ball  $B = \overline{B}(x_0, R + 2r)$ . Since distinct lines of  $\mathcal{L}$  are not parallel, there exists a finite upper bound  $D = D(r)$  on the diameter of the intersection  $\mathcal{N}_r(\ell) \cap \mathcal{N}_r(\ell')$  for all lines  $\ell \neq \ell' \in \mathcal{L}$  that intersect  $B$ .

Consider  $\ell_1 \neq \ell_2 \in \mathcal{L}$ . If  $d(\ell_1, \ell_2) \geq 2r$  then their  $r$ -neighborhoods have empty intersection, and the result is vacuously true. Thus it suffices to assume that  $d(\ell_1, \ell_2) < 2r$ . By cocompactness, there exists  $h \in H$  so that  $h(\ell_1)$  intersects  $\overline{B}(x_0, R)$ . But then  $h(\ell_1)$  and  $h(\ell_2)$  both intersect  $B$ , so that

$$\text{diam}(\mathcal{N}_r(\ell_1) \cap \mathcal{N}_r(\ell_2)) \leq D,$$

as desired. □

**Lemma 1.3.3.** *Let  $S$  be a compact hyperbolic surface with totally geodesic (possibly empty) boundary, and let  $\mathcal{C}$  be a nonempty geodesic multicurve. Then there exists a geodesic loop  $\gamma$  in  $S$  such that  $\gamma$  and  $\mathcal{C}$  have nonempty intersection.*

*Proof.* Choose any loop  $c \in \mathcal{C}$ . Cutting  $S$  along  $c$  produces a surface each of whose components has negative Euler characteristic since each of its components is a union of blocks of  $S$  joined along circles. For any such simple closed curve  $c$  in a compact surface  $S$ , we claim that there exists another closed curve  $\gamma$  whose geometric intersection number with  $c$  is nonzero. We leave the proof of this claim as an easy exercise for the reader (using, for example, the techniques in Sections 1.2.4 and 1.3 of [FM12]). After applying a homotopy, we can assume that  $\gamma$  is a geodesic loop.  $\square$

**Lemma 1.3.4.** *Let  $S$  be a compact hyperbolic surface with totally geodesic (possibly empty) boundary, and let  $\mathcal{C}$  be a nonempty geodesic multicurve. Let  $\mathcal{L}$  be the family of lines that are lifts of loops of  $\mathcal{C}$  or boundary loops of  $S$ . For any  $\kappa > 0$ , there exist numbers  $\mu$ ,  $L$ , and  $C$  such that the following holds.*

*Consider a piecewise geodesic  $c = \alpha_1\beta_1 \cdots \alpha_n\beta_n$  in the universal cover  $\tilde{S}$ . Suppose each segment  $\alpha_j$  is contained in a line of  $\mathcal{L}$ , and each segment  $\beta_j$  meets the lines of  $\mathcal{L}$  only at its endpoints. If  $|\beta_j| \leq \kappa$  and  $|\alpha_j| \geq \mu$  for all  $j$ , then  $c$  is an  $(L, C)$ -quasigeodesic.*

*Proof.* In order to show that the piecewise geodesic  $c$  in the  $\delta$ -hyperbolic space  $\tilde{S}$  is uniformly quasigeodesic, we will show that there exists a constant  $D$  such that whenever  $\mu$  is sufficiently large,  $c$  satisfies the hypotheses of Theorem 1.2.6. Thus  $c$  is  $(L, C)$ -quasigeodesic for constants  $L$  and  $C$  not depending on  $c$ .

Let  $Q = 4\delta + \kappa$ . Let  $D = D(Q)$  be the constant given by applying Lemma 1.3.2 to the hyperbolic surface  $S$  and the multicurve  $\mathcal{C}$ . Let  $L = L(\delta, \kappa, D)$  and  $C = C(\delta, \kappa, D)$  be the constants given by Theorem 1.2.6. We define  $\mu = 11\kappa + 25\delta + 2D$ . It follows that  $c$  satisfies Conditions (1) and (2) of Theorem 1.2.6.

In order to verify Condition (3) of Theorem 1.2.6, we need to show that  $\text{dev}_Q(\alpha_j, \alpha_{j+1}) \leq D$ . Let  $u \in \alpha_j$  and  $v \in \alpha_{j+1}$  such that  $d(u, v) \leq Q$ . Let  $u'$  and  $v'$  be the initial and terminal

points of  $\beta_j$ . We need to show that  $d(u, u') \leq D$  and  $d(v, v') \leq D$ . It is easy to see the elements  $u, v, u'$ , and  $v'$  belong to  $\mathcal{N}_Q(\alpha_j) \cap \mathcal{N}_Q(\alpha_{j+1})$  because  $|\beta_j| \leq \kappa \leq Q$ . We have  $\alpha_{j+1}$  and  $\alpha_j$  do not belong to the same line of  $\mathcal{L}$  because any two distinct geodesics in  $\tilde{S}$  intersect at most one point. Hence

$$\text{diam}(\mathcal{N}_Q(\alpha_j) \cap \mathcal{N}_Q(\alpha_{j+1})) \leq D$$

by Lemma 1.3.2. It follows that  $d(u, u') \leq D$  and  $d(v, v') \leq D$ . It follows immediately from the definition of the deviation that  $\text{dev}_Q(\alpha_j, \alpha_{j+1}) \leq D$ .  $\square$

## 1.4 Graph manifolds and horizontal surfaces

In this section, we review background about graph manifolds and horizontal surfaces. In addition, we discuss a convenient metric for a graph manifold that will be used in next sections. We refer the reader to [RW98], [BS04] and [KL98] for more details.

**Definition 1.4.1.** A *graph manifold* is a compact, irreducible, connected, orientable 3-manifold  $N$  that can be decomposed along embedded incompressible tori  $\mathcal{T}$  into finitely many Seifert manifolds. We specifically exclude Sol and Seifert manifolds from the class of graph manifolds. Up to isotopy, each graph manifold has a unique minimal collection of tori  $\mathcal{T}$  as above [JS79, Joh79]. This minimal collection is the *JSJ decomposition* of  $N$ , and each torus of  $\mathcal{T}$  is a *JSJ torus*.

Throughout this paper, a graph consists of a set  $\mathcal{V}$  of vertices and a set of  $\mathcal{E}$  of edges, each edge being associated to an unordered pair of vertices by a function  $\text{ends}: \text{ends}(e) = \{v, v'\}$  where  $v, v' \in \mathcal{V}$ . In this case we call  $v$  and  $v'$  the *endpoints* of the edge  $e$  and we also say  $v$  and  $v'$  are adjacent.

**Definition 1.4.2.** A *simple graph manifold*  $N$  is a graph manifold with the following properties:

1. Each Seifert component is a trivial circle bundle over an orientable surface of genus at least 2.
2. The intersection numbers of fibers of adjacent Seifert components have absolute value 1.

**Theorem 1.4.3** ( [KL98]). *Any graph manifold  $N$  has a finite cover  $\hat{N}$  that is a simple graph manifold.*

**Definition 1.4.4.** Let  $M$  be a Seifert manifold with boundary. A *horizontal surface* in  $M$  is an immersion  $g: B \looparrowright M$  where  $B$  is a compact surface with boundary such that the image  $g(B)$  is transverse to the Seifert fibration. We also require that  $g$  is *properly immersed*, ie,  $g(B) \cap \partial M = g(\partial B)$ .

A *horizontal surface* in a graph manifold  $N$  is a properly immersed surface  $g: S \looparrowright N$  such that for each Seifert component  $M$ , the intersection  $g(S) \cap M$  is a horizontal surface in  $M$ . A horizontal surface  $g$  in a graph manifold  $N$  is always  $\pi_1$ -injective and lifts to an embedding of  $S$  in the cover of  $N$  corresponding to the subgroup  $g_*(\pi_1(S))$  by [RW98]. Consequently,  $g$  also lifts to an embedding  $\tilde{S} \rightarrow \tilde{N}$  of universal covers.

**Definition 1.4.5.** A horizontal surface  $g: S \looparrowright N$  in a graph manifold  $N$  is *virtually embedded* if  $g$  lifts to an embedding of  $S$  in some finite cover of  $N$ . By a theorem of Scott [Sco78], a horizontal surface is virtually embedded if  $g_*(\pi_1(S))$  is a *separable* subgroup of  $\pi_1(N)$ , i.e., it is equal to an intersection of finite index subgroups. Przytycki–Wise have shown that the converse holds as well [PW14b].

The following result about separability allows one to pass to finite covers in the study of horizontal surfaces, as explained in Corollary 1.4.7.

**Proposition 1.4.6** ( [Sco78], Lemma 1.1). *Let  $G_0$  be a finite index subgroup of  $G$ . A subgroup  $H \leq G$  is separable in  $G$  if and only if  $H \cap G_0$  is separable in  $G_0$ .*

**Corollary 1.4.7.** *Let  $q: (\hat{N}, \hat{x}_0) \rightarrow (N, x_0)$  be a finite covering of graph manifolds. Let  $g: (S, s_0) \looparrowright (N, x_0)$  be a horizontal surface. Let  $p: (\hat{S}, \hat{s}_0) \rightarrow (S, s_0)$  be the finite cover corresponding to the subgroup  $g_*^{-1}q_*\pi_1(\hat{N}, \hat{x}_0)$ . Then  $g$  lifts to a horizontal surface  $\hat{g}: (\hat{S}, \hat{s}_0) \rightarrow (\hat{N}, \hat{x}_0)$ . Furthermore  $g$  is a virtual embedding if and only if  $\hat{g}$  is a virtual embedding.*

**Definition 1.4.8.** Suppose  $g: S \looparrowright N$  is a horizontal surface in a graph manifold  $N$  with JSJ decomposition  $\mathcal{T}$ . Let  $\mathcal{T}_g$  denote the collection of components of  $g^{-1}(\mathcal{T})$  in  $S$ . After applying a homotopy to  $g$ , we may assume that the image  $g(c)$  of each curve  $c \in \mathcal{T}_g$  is a multiple of a simple closed curve on the corresponding JSJ torus. The connected components of the splitting  $S|g^{-1}(\mathcal{T})$  are the *blocks*  $B$  of  $S$ .

**Remark 1.4.9.** If  $g: S \looparrowright N$  is a horizontal surface then  $\mathcal{T}_g$  is always nonempty. Indeed,  $g(S)$  has nonempty intersection with each JSJ torus of  $N$  because a properly immersed horizontal surface in a connected graph manifold must intersect every fiber of every Seifert component (see Lemma 1.6.3 for details).

In [RW98], Rubinstein–Wang introduced the dilation of a horizontal surface, and proved that dilation is the obstruction to a surface being virtually embedded (see Theorem 1.4.11).

**Definition 1.4.10** (Dilation). Let  $g: (S, s_0) \looparrowright (N, x_0)$  be a horizontal surface in a simple graph manifold  $N$ . Choose an orientation for the graph manifold  $N$ , an orientation for the fiber of each Seifert component, and an orientation for each curve  $c \in \mathcal{T}_g$ .

The *dilation* of a horizontal surface  $S$  in  $N$  is a homomorphism  $w: \pi_1(S, s_0) \rightarrow \mathbb{Q}_+^*$  defined as follows. Choose  $[\gamma] \in \pi_1(S, s_0)$  such that  $\gamma$  is transverse to  $\mathcal{T}_g$ . In the trivial case that  $\gamma$  is disjoint from the curves of the collection  $\mathcal{T}_g$ , we set  $w(\gamma) = 1$ . Let us assume now that this intersection is nonempty. Then  $\mathcal{T}_g$  subdivides  $\gamma$  into a concatenation  $\gamma_1 \cdots \gamma_m$  with the following properties. Each path  $\gamma_i$  starts on a circle  $c_i \in \mathcal{T}_g$  and ends on the circle  $c_{i+1}$ . The image  $g(\gamma_i)$  of this path in  $N$  lies in a Seifert component  $M_i$ . The image of the circle  $g(c_i)$  in  $N$  lies in a JSJ torus  $T_i$  obtained by gluing a boundary torus  $\overleftarrow{T}_i$  of  $M_{i-1}$  to a boundary torus  $\overrightarrow{T}_i$  of  $M_i$ . Let  $\overleftarrow{f}_i$  and  $\overrightarrow{f}_i$  be fibers of  $M_{i-1}$  and  $M_i$  in the torus  $T_i$ . By Definition 1.4.2,

the 1-cycles  $[\overleftarrow{f}_i]$  and  $[\overrightarrow{f}_i]$  generate the integral homology group  $H_1(T_i) \cong \mathbb{Z}^2$ , so there exist integers  $a_i$  and  $b_i$  such that

$$[g(c_i)] = a_i[\overleftarrow{f}_i] + b_i[\overrightarrow{f}_i] \quad \text{in } H_1(T_i).$$

Since the immersion is horizontal, these coefficients  $a_i$  and  $b_i$  must be nonzero. The dilation  $w(\gamma)$  is the rational number  $\prod_{i=1}^m |b_i/a_i|$ . Note that  $w(\gamma)$  depends only on the homotopy class of  $\gamma$ , since crossings of  $\gamma$  with a curve  $c \in \mathcal{T}_g$  in opposite directions contribute terms to the dilation that cancel each other. For the rest of this paper we write  $w_\gamma$  instead of  $w(\gamma)$ .

The following result is a special case of [RW98, Theorem 2.3].

**Theorem 1.4.11.** *A horizontal surface  $g: S \looparrowright N$  in a simple graph manifold is virtually embedded if and only if the dilation  $w$  is the trivial homomorphism.*

**Remark 1.4.12.** Let  $g: S \looparrowright N$  be a horizontal surface in a simple graph manifold  $M$ , then each block  $B$  is a connected surface with non-empty boundary and negative Euler characteristic. Indeed, the immersion  $g: S \looparrowright N$  maps  $B$  to the corresponding Seifert component  $M$  with base surface  $F$ . The composition of  $g|_B$  with the projection of  $M$  to  $F$  yields a finite covering map from  $B$  to  $F$ . Since  $\chi(F) < 0$ , it follows that  $\chi(B) < 0$  as well.

We note that the collection  $\mathcal{T}_g$  is always a non-empty multicurve. Indeed,  $\mathcal{T}_g$  is nonempty by Remark 1.4.9. Since the blocks of  $S$  have negative Euler characteristic, it follows that  $\mathcal{T}_g$  is a multicurve.

**Remark 1.4.13.** We now are going to describe a convenient metric on a simple graph manifold  $N$  introduced by Kapovich–Leeb [KL98]. For each Seifert component  $M_i = F_i \times S^1$  of  $N$ , we choose a hyperbolic metric on the base surface  $F_i$  so that all boundary components are totally geodesic of unit length, and then equip each Seifert component  $M_i = F_i \times S^1$  with the product metric  $d_i$  such that the fibers have length one. Metrics  $d_i$  on  $M_i$  induce the product metrics on  $\tilde{M}_i$  which by abuse of notations is also denoted by  $d_i$ .

Let  $M_i$  and  $M_j$  be adjacent Seifert components in the simple graph manifold  $N$ , and let  $T \subset M_i \cap M_j$  be a JSJ torus. Each metric space  $(\tilde{T}, d_i)$  and  $(\tilde{T}, d_j)$  is a Euclidean plane. After applying a homotopy to the gluing map, we may assume that at each JSJ torus  $T$ , the gluing map  $\phi$  from the boundary torus  $\overleftarrow{T} \subset M_i$  to the boundary torus  $\overrightarrow{T} \subset M_j$  is affine in the sense that the identity map  $(\tilde{T}, d_i) \rightarrow (\tilde{T}, d_j)$  is affine. We now have a product metric on each Seifert component  $M_i = F_i \times S^1$ . These metrics may not agree on the JSJ tori but the gluing maps are bilipschitz (since they are affine). The product metrics on the Seifert components induce a length metric on the graph manifold  $N$  denoted by  $d$  (see Section 3.1 of [BBI01] for details). Moreover, there exists a positive constant  $K$  such that on each Seifert component  $M_i = F_i \times S^1$  we have

$$\frac{1}{K} d_i(x, y) \leq d(x, y) \leq K d_i(x, y)$$

for all  $x$  and  $y$  in  $M_i$ . (See Lemma 1.8 of [Pau05] for a detailed proof of the last claim.) Metric  $d$  on  $N$  induces metric on  $\tilde{N}$ , which is also denoted by  $d$  (by abuse of notations). Then for all  $x$  and  $y$  in  $\tilde{M}_i$  we have

$$\frac{1}{K} d_i(x, y) \leq d(x, y) \leq K d_i(x, y)$$

The following remark introduces certain invariants of a horizontal surface  $g$  that will be used in the proof of Theorem 1.6.1.

**Remark 1.4.14.**

1. Since  $N$  is compact, there exists a positive lower bound  $\rho$  for the distance between any two distinct JSJ planes in  $\tilde{N}$ .
2. We recall that for each curve  $c_i$  in  $\mathcal{T}_g$ , there exist non-zero integers  $a_i$  and  $b_i$  such that

$$[g(c_i)] = a_i[\overleftarrow{f}_i] + b_i[\overrightarrow{f}_i] \quad \text{in} \quad H_1(T_i).$$

The *governor* of a horizontal surface  $g: S \looparrowright N$  in a graph manifold is the quantity  $\epsilon = \epsilon(g) = \max\{|a_i/b_i|, |b_i/a_i| \mid c_i \in \mathcal{T}_g\}$ . (We use the term “governor” here in the sense of a device used to limit the top speed of a vehicle or engine. In this context the governor limits the rate of growth of the products used in calculating the dilation of curves in the surface.)

**Proposition 1.4.15.** *For each  $[\gamma] \in \pi_1(S, s_0)$  as in Definition 1.4.10, we define*

$$\Lambda_\gamma = \max\left\{\prod_{i=j}^k |b_i/a_i| \mid 1 \leq j \leq k \leq m\right\}$$

*If the horizontal surface  $g$  is a virtual embedding, then there exists a positive constant  $\Lambda$  such that  $\Lambda_\gamma \leq \Lambda$  for all  $[\gamma] \in \pi_1(S, s_0)$ .*

*Proof.* Let  $\Gamma_g$  be the graph dual to  $\mathcal{T}_g$ , and let  $n$  be the number of vertices in  $\Gamma_g$ . Each oriented edge  $e$  of  $\Gamma_g$  is dual to a curve  $c \in \mathcal{T}_g$  and determines a slope  $|b/a|$  as described in Definition 1.4.10 and Remark 1.4.14. By Theorem 1.4.11 the dilation is trivial for any loop in  $S$ . Therefore for each cycle  $e_1 \cdots e_m$  in  $\Gamma_g$  the corresponding product of slopes  $\prod_{i=1}^m |b_i/a_i|$  is trivial. It follows that for any edge path  $e_1 \cdots e_m$  the value of the product  $\prod_{i=1}^m |b_i/a_i|$  depends only on the endpoints of the path. Each slope  $|b_i/a_i|$  is bounded above by the governor  $\epsilon$  of  $g$ . Since any two vertices of  $\Gamma_g$  are joined by a path of length less than  $n$ , the result follows, using  $\Lambda = \epsilon^n$ .  $\square$

**Remark 1.4.16.** Let  $g: S \looparrowright N$  be a horizontal surface in a simple graph manifold. Equip  $N$  with the metric  $d$  described in Remark 1.4.13. By [Neu01, Lemma 3.1] the surface  $g$  can be homotoped to another horizontal surface  $g': S \looparrowright N$  such that the following holds: For each curve  $c$  in  $g'^{-1}(\mathcal{T})$ , let  $T$  be the JSJ torus in  $N$  such that  $g'(c) \subset T$ . Then  $g'(c)$  is *straight* in  $T$  in the sense that lifts of  $g'(c)$  to  $\tilde{N}$  are straight lines in the JSJ planes containing it.

**Remark 1.4.17.** Let  $f: S^1 \looparrowright T = S^1 \times S^1$  be a horizontal immersion. Then every fiber  $\{x\} \times S^1$  in the torus  $T$  has non-empty intersection with  $f(S^1)$ . Indeed, this follows from

the fact the composition of  $f$  with the natural projection of  $T$  to the first factor  $S^1$  is a finite covering map.

## 1.5 A lower bound for distortion

The main theorem in this section is the following.

**Theorem 1.5.1.** *Let  $g: (S, s_0) \looparrowright (N, x_0)$  be a horizontal surface in a graph manifold  $M$ . Let  $G = \pi_1(N, x_0)$  and  $H = g_*(\pi_1(S, s_0))$ . Then the distortion  $\Delta_H^G$  is at least quadratic. Furthermore, if the horizontal surface  $g$  is not virtually embedded, then the distortion  $\Delta_H^G$  is at least exponential.*

To see the proof of Theorem 1.5.1, we need several lemmas. For the rest of this section we fix a horizontal surface  $g: S \looparrowright N$  in a simple graph manifold  $N$ . We equip  $N$  with the metric  $d$  described in Remark 1.4.13 and equip  $S$  with a hyperbolic metric  $d_S$  such that the boundary (if nonempty) is totally geodesic and the simple closed curves of  $\mathcal{T}_g$  are geodesics.

**Lemma 1.5.2.** *Let  $\gamma$  be any geodesic loop in  $S$  such that  $\gamma$  and  $\mathcal{T}_g$  have nonempty intersection and such that  $w_\gamma \geq 1$ . There exists a positive number  $A = A(\gamma)$  such that for all  $\mu > 0$  the following holds: Let  $\{c_1, \dots, c_m\}$  be the sequence of curves of  $\mathcal{T}_g$  crossed by  $\gamma$ . The image of the circle  $g(c_i)$  in  $M$  lies in a JSJ torus  $T_i$ . For each  $i = 1, 2, \dots, m$ , let  $a_i$  and  $b_i$  be the integers such that*

$$[g(c_i)] = a_i[\overleftarrow{f_i}] + b_i[\overrightarrow{f_i}] \quad \text{in } H_1(T_i; \mathbb{Z}).$$

*Extend the sequence  $a_1, \dots, a_m$  to a periodic sequence  $\{a_j\}_{j=1}^\infty$  with  $a_{j+m} = a_j$  for all  $j > 0$ , and similarly extend  $b_1, \dots, b_m$  to an  $m$ -periodic sequence  $\{b_j\}_{j=1}^\infty$ . Then there exists a (nonperiodic) sequence of integers  $\{t(j)\}_{j=1}^\infty$ , depending on our choice of the constant  $\mu$  and the loop  $\gamma$ , with the following properties:*

1.  $|t(j)| \geq \mu$  for all  $j$ .
2.  $|t(j)a_j + t(j-1)b_{j-1}| \leq A$  for all  $j > 1$ .

3. The partial sum  $f(n) = \sum_{j=1}^{nm} |t(j)|$  satisfies  $f(n) \succeq n^2 + w_\gamma^n$ .

*Proof.* By the definition of the dilation function, we have  $w_\gamma = \prod_{i=1}^m |b_i/a_i|$ .

Let  $A = \max\{1 + |a_i| \mid i = 1, 2, \dots, m\}$ . Set  $\xi = \min\{|1/a_j|\}$ , and choose  $\lambda \in (0, 1]$  so that  $\lambda \leq |b_{j-1}/a_j|$  for all  $j > 1$ . Starting from an initial value  $t(1) \geq \mu/\lambda^{m-1}$ , we recursively construct an infinite sequence  $\{t(j)\}$  satisfying (2). Suppose that  $t(j-1)$  has been defined for some  $j > 1$ , and we wish to define  $t(j)$ . As  $A \geq 1 + |a_j|$ , we have

$$1 \leq \frac{A-1}{|a_j|} = \frac{A + |t(j-1)b_{j-1}|}{|a_j|} - \frac{1 + |t(j-1)b_{j-1}|}{|a_j|}.$$

It follows that there is an integer  $t(j)$  such that

$$\frac{1 + |t(j-1)b_{j-1}|}{|a_j|} \leq |t(j)| \leq \frac{A + |t(j-1)b_{j-1}|}{|a_j|}, \quad (\clubsuit)$$

which is equivalent to

$$1 \leq |t(j)a_j| - |t(j-1)b_{j-1}| \leq A.$$

Furthermore, we are free to choose the sign of  $t(j)$  so that  $t(j)a_j$  and  $t(j-1)b_{j-1}$  have opposite signs, which immediately gives (2). By induction, the sequence  $\{t(j)\}$  satisfies both  $(\clubsuit)$  and (2) for all  $j > 1$ .

We next show that any sequence  $\{t(j)\}$  satisfying  $(\clubsuit)$  also satisfies (3). Indeed, the first inequality of  $(\clubsuit)$  implies

$$|t(j)| \geq \frac{1}{|a_j|} + \left| \frac{b_{j-1}}{a_j} \right| |t(j-1)| \geq \left| \frac{b_{j-1}}{a_j} \right| |t(j-1)| \quad \text{for all } j > 1. \quad (\diamond)$$

For any  $j > m$ , we apply  $(\diamond)$  iteratively  $m$  times (and use that the sequences  $\{a_j\}$  and  $\{b_j\}$

are  $m$ -periodic) to get

$$\begin{aligned}
|t(j)| &\geq \frac{1}{|a_j|} + \left| \frac{b_{j-1}}{a_j} \right| |t(j-1)| \\
&\geq \frac{1}{|a_j|} + \left| \frac{b_{j-1} b_{j-2}}{a_j a_{j-1}} \right| |t(j-2)| \geq \dots \\
&\geq \frac{1}{|a_j|} + \left| \frac{b_1 \cdots b_m}{a_1 \cdots a_m} \right| |t(j-m)| \\
&\geq \xi + w_\gamma |t(j-m)|.
\end{aligned} \tag{\heartsuit}$$

Further applying  $(\heartsuit)$  iteratively  $k$  times (and using that  $w_\gamma \geq 1$ ) gives

$$\begin{aligned}
|t(j)| &\geq \xi + w_\gamma |t(j-m)| \\
&\geq \xi + w_\gamma (\xi + w_\gamma |t(j-2m)|) \\
&\geq 2\xi + w_\gamma^2 |t(j-2m)| \geq \dots \\
&\geq \xi k + w_\gamma^k |t(j-km)| \quad \text{for all } j > km
\end{aligned} \tag{\spadesuit}$$

The inequality  $(\spadesuit)$  can be rewritten in the form

$$|t(km+1)| \geq \xi k + |t(1)| w_\gamma^k \quad \text{for all } k > 0.$$

Finally for each positive  $n$  we observe that

$$\sum_{j=1}^{nm} |t(j)| \geq \sum_{k=1}^{n-1} |t(km+1)| \geq \xi \sum_{k=1}^{n-1} k + |t(1)| \sum_{k=1}^{n-1} w_\gamma^k$$

which implies  $(3)$  as desired.

In order to establish  $(1)$ , recall that  $\gamma$  satisfies  $w_\gamma \geq 1$ . Therefore  $(\heartsuit)$  implies that  $|t(j)| \geq |t(j-m)|$  for any  $j > m$ . In particular, it follows that the terms of the sequence  $\{t(j)\}$  have absolute value bounded below by the absolute values of the first  $m$  terms:  $t(1), \dots, t(m)$ .

Using our choice of  $t(1) \geq \mu/\lambda^{m-1}$  and the fact  $\lambda \leq |b_{j-1}/a_j|$ , the inequality  $(\diamond)$  shows

that for all  $i = 1, \dots, m$  we have

$$|t(i)| \geq \lambda^{i-1} |t(1)| \geq \frac{\mu}{\lambda^{m-i}}.$$

As  $\lambda \leq 1$ , we conclude that  $|t(i)| \geq \mu$ , completing the proof of (1).  $\square$

**Definition 1.5.3** (spirals). We let  $\gamma$  be a closed curve in  $S$  satisfying the conclusion of Lemma 1.3.3. Let  $\{c_1, \dots, c_m\}$  be the sequence of curves of  $\mathcal{C}$  crossed by  $\gamma$ . Let  $\{\gamma_1, \dots, \gamma_m\}$  be the sequence of subpaths of  $\gamma$  introduced in Definition 1.4.10. Extend the finite sequences of curves  $c_1, \dots, c_m$  and  $\gamma_1, \dots, \gamma_m$  to  $m$ -periodic infinite sequences  $\{c_j\}_{j=1}^\infty$  and  $\{\gamma_j\}_{j=1}^\infty$ . Let  $\{t(j)\}$  be a sequence of integers. We denote  $\alpha_j = c_j^{t(j)}$ .

Choose the basepoint  $s_0 \in S$  to be a point of intersection between  $\gamma$  and one of the curves of the family  $\mathcal{C}$ . For each  $n \in \mathbb{N}$ , we define a *spiral* loop  $\sigma_n$  in  $S$  based at  $s_0$  as a concatenation:

$$\sigma_n = \alpha_1 \gamma_1 \cdots \alpha_{nm} \gamma_{nm}$$

and a *double spiral* loop  $\rho_n$  of  $\sigma_n$  in  $S$  based at  $s_0$  as  $\rho_n = \sigma_n \alpha'_{nm+1} \sigma_n^{-1}$  where  $\alpha'_{nm+1} = c_{nm+1}^{t(1)}$ .

**Lemma 1.5.4.** *Let  $\{t(j)\}_{j=1}^\infty$  be the sequence of integers given by Lemma 1.5.2. Let  $\rho_n$  be the double spiral loop of  $\sigma_n$  corresponding to the curve  $\gamma$  and the sequence  $\{t(j)\}$ . Let  $\tilde{\rho}_n$  be the lift of  $\rho_n$  in  $\tilde{S}$ . Then the distance in  $\tilde{N}$  between the endpoints of  $\tilde{g}(\tilde{\rho}_n)$  is bounded above by a linear function of  $n$ .*

*Proof.* First we describe informally the idea of the proof, which is illustrated in Figure 1.1. The lift  $\tilde{\sigma}_n$  of  $\sigma_n$  is the spiral-shaped curve running around the outside of the left-hand diagram. The path  $\tilde{\sigma}_n$  alternates between long segments  $\tilde{\alpha}_j$  belonging to JSJ planes and short segments  $\tilde{\gamma}_j$  belonging to Seifert components. Each long segment  $\tilde{\alpha}_j$  is one side of a large triangle in the JSJ plane whose other two sides are fibers of the adjacent blocks, which meet in a corner  $y_j$  opposite to  $\tilde{\alpha}_j$ . Connecting each pair of adjacent corners  $y_j$  produces a thin trapezoid that interpolates between two adjacent JSJ triangles. We will see that

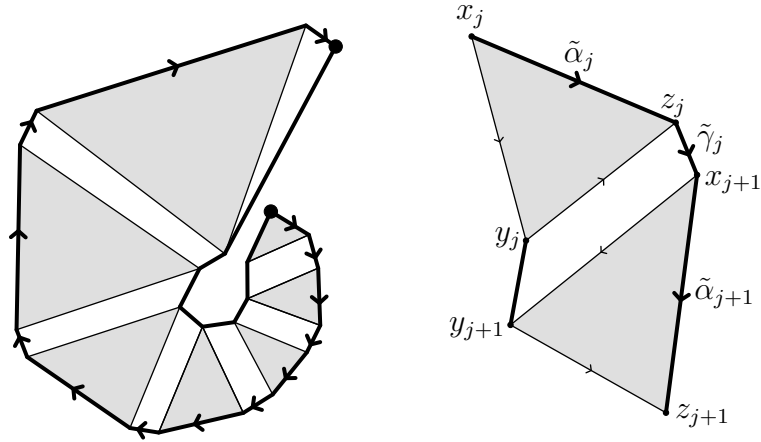

Figure 1.1: On the left, the piecewise geodesic  $\tilde{\sigma}_n$  is the spiral-shaped path running around the outside of the diagram. On the right is a magnified portion of the left-hand picture showing more detail.

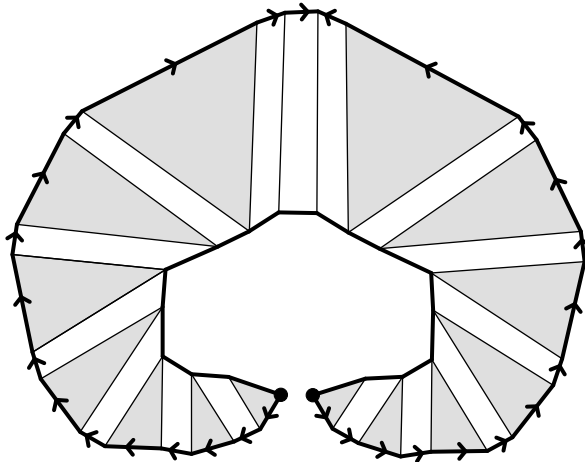

Figure 1.2: The outer path represents the piecewise geodesic  $\tilde{\rho}_n$ .

the sequence of exponents  $\{t(j)\}$  in the construction of  $\tilde{\sigma}_n$  was chosen carefully to ensure that the distances between adjacent corners  $y_j$  are all short, *i.e.*, bounded above. Thus the path running around the inside of the spiral has at most a linear length—except for its last segment, which is a long side of a large JSJ triangle. The double spiral gives rise to a diagram similar to the spiral diagram, except that it has been doubled along this long triangular side, so that the long side no longer appears on the boundary of the diagram but rather appears in its interior (see Figure 1.2).

To be more precise, let  $M_j$  be the Seifert component of  $N$  containing  $\gamma_j$ , with its given

product metric as a hyperbolic surface crossed with a circle of length one. Let  $(\tilde{M}_j, d_j)$  be the Seifert component of  $\tilde{N}$  that contains  $\tilde{\gamma}_j$ , with the product metric  $d_j$  induced by lifting the given metric on  $M_j$ . Let  $\tilde{T}_j$  be the JSJ plane containing  $\tilde{\alpha}_j$ . Recall that  $\tilde{T}_j$  is a topological plane that is a subspace of both  $\tilde{M}_{j-1}$  and  $\tilde{M}_j$ . However the metrics  $d_{j-1}$  and  $d_j$  typically do not agree on the common subspace  $\tilde{T}_j$ . Each metric space  $\overleftarrow{E}_j = (\tilde{T}_j, d_{j-1})$  and  $\overrightarrow{E}_j = (\tilde{T}_j, d_j)$  is a Euclidean plane and the identity map  $\overleftarrow{E}_j \rightarrow \overrightarrow{E}_j$  is affine.

The plane  $\tilde{T}_j$  universally covers a JSJ torus  $T_j$  obtained by identifying boundary tori  $\overleftarrow{T}_j$  and  $\overrightarrow{T}_j$  of Seifert components  $M_{j-1}$  and  $M_j$ . The initial and terminal points  $x_j$  and  $z_j$  of  $\tilde{\alpha}_j$  are contained in Euclidean geodesics  $\overleftarrow{\ell}_j \subset \overleftarrow{E}_j$  and  $\overrightarrow{\ell}_j \subset \overrightarrow{E}_j$  that project to fibers  $\overleftarrow{f}_j \subset \overleftarrow{T}_j$  and  $\overrightarrow{f}_j \subset \overrightarrow{T}_j$  respectively. The lines  $\overleftarrow{\ell}_j$  and  $\overrightarrow{\ell}_j$  intersect in a unique point  $y_j$ . Similarly, we consider the subpath  $\tilde{\alpha}_j^{-1}$  in the double spiral  $\tilde{\rho}_n$ . Let  $\bar{y}_j$  be the intersection point of the two fibers that contain its endpoints.

Our goal is to find a linear upper bound for the distance in  $(N, d)$  between the endpoints of  $\tilde{\rho}_n$ . By the triangle inequality it suffices to produce an upper bound for the distance between successive points of the linear sequence  $y_1, \dots, y_{nm}, \bar{y}_{nm}, \dots, \bar{y}_1$ . Recall that the inclusions  $(\tilde{M}_j, d_j) \rightarrow (\tilde{N}, d)$  are  $K$ -bilipschitz for some universal constant  $K$ , as explained in Remark 1.4.13. Thus it is enough to bound the distance between these points with respect to the given product metrics on each Seifert component.

Let  $\eta$  be the maximum of lengths of  $\tilde{\gamma}_j$  with respect to metric  $d_j$ . Let  $A$  be the constant given by Lemma 1.5.2. We claim that

$$d_j(y_j, y_{j+1}) \leq \eta + A. \quad (\star)$$

We prove this claim by examining the quadrilateral with vertices  $y_j$ ,  $z_j$ ,  $x_{j+1}$ , and  $y_{j+1}$ , illustrated on the right-hand side of Figure 1.1. This quadrilateral is a trapezoid in the sense that the opposite sides  $[y_j, z_j]$  and  $[y_{j+1}, x_{j+1}]$  lie in fibers of  $\tilde{M}_j$  that are parallel lines in the product metric  $d_j$ .

To find the lengths of these parallel sides, we examine the JSJ triangle  $\Delta(x_j, y_j, z_j)$ , also shown on the right-hand side of Figure 1.1. We consider this triangle to be a pair of homotopic paths  $\tilde{\alpha}_j$  and  $\tau_j$  from  $x_j$  to  $y_j$  in the plane  $\tilde{T}_j$ , where  $\tau_j = [x_j, y_j] \cup [y_j, z_j]$  is a segment of  $\overleftarrow{\ell}_j$  concatenated with a segment of  $\overrightarrow{\ell}_j$ . In particular,  $\tilde{\alpha}_j$  and  $\tau_j$  project to homotopic loops in  $T_j$  of the form  $g(\alpha_j)$  and  $(\overleftarrow{f}_j)^{r_j}(\overrightarrow{f}_j)^{s_j}$  for some  $r_j, s_j \in \mathbb{Z}$ . Recall that the fiber  $\overleftarrow{f}_j$  has length one in the product metric on  $M_{j-1}$ . Similarly the fiber  $\overrightarrow{f}_j$  has length one in  $M_j$ . It follows that  $d_{j-1}(x_j, y_j) = |r_j|$  and  $d_j(y_j, z_j) = |s_j|$ . Since  $g(\alpha_j) = g(c_j)^{t(j)}$ , the homology relation (written additively)

$$t(j) [g(c_j)] = t(j) a_j [\overleftarrow{f}_j] + t(j) b_j [\overrightarrow{f}_j] \quad \text{in} \quad H_1(T_j; \mathbb{Z}) \approx \pi_1(T_j),$$

implies that  $r_j = t(j) a_j$  and  $s_j = t(j) b_j$ .

Let  $\beta_j$  be the lift of  $\gamma_j$  based at  $y_j$ . The fiber which contains  $y_{j+1}$  and  $x_{j+1}$  will intersect  $\beta_j$  exactly at one point. We denote this point by  $u_j$ . It follows that  $d_j(u_j, y_j) \leq \eta$  and  $d_j(u_j, y_{j+1}) = |t(j+1) a_{j+1} + t(j) b_j|$ . Using the triangle inequality for  $\Delta(y_j, u_j, y_{j+1})$ , we have

$$\begin{aligned} d_j(y_j, y_{j+1}) &\leq d_j(y_j, u_j) + d_j(u_j, y_{j+1}) \\ &\leq \eta + |t(j+1) a_{j+1} + t(j) b_j| \\ &\leq \eta + A \end{aligned}$$

by Lemma 1.5.2(2), completing the proof of  $(\star)$ .

For a similar reason, the distance in the corresponding Seifert component between  $\bar{y}_j$  and  $\bar{y}_{j-1}$  is at most  $\eta + A$ . Thus it suffices to find an upper bound for  $d_{nm}(y_{nm}, \bar{y}_{nm})$ . Let  $R$  be the length of  $\tilde{c}_1$  in the metric  $d_{nm}$ . Let  $\bar{z}_{nm}$  be the initial point of  $\tilde{\alpha}_{nm}^{-1}$ . Since  $\alpha'_{nm} = c_{nm+1}^{t(1)}$ , the  $d_{nm}$ -distance between the endpoints of  $\tilde{\alpha}'_{nm+1}$  is at most  $R |t(1)|$ . By the triangle inequality,  $d_{nm}(z_{nm}, \bar{z}_{nm}) \leq 2\eta + R |t(1)|$ .

We note that  $[z_{nm}, y_{nm}]$  and  $[\bar{z}_{nm}, \bar{y}_{nm}]$  lie in parallel fibers of  $\tilde{M}_{nm}$ . Furthermore they are

oriented in the same direction with respect to the fiber and have the same length. Therefore they form opposite sides of a Euclidean parallelogram in  $\tilde{M}_{nm}$ . In particular the distances  $d_{nm}(y_{nm}, \bar{y}_{nm})$  and  $d_{nm}(z_{nm}, \bar{z}_{nm})$  are equal, so that  $d_{nm}(y_{nm}, \bar{y}_{nm}) \leq 2\eta + R|t(1)|$ .  $\square$

*Proof of Theorem 1.5.1.* Any graph manifold has a simple finite cover by Theorem 1.4.3. By Corollary 1.4.7 and Proposition 1.2.9, it suffices to prove the theorem for all horizontal surfaces in this cover. Thus we assume, without loss of generality that  $N$  is a simple graph manifold.

Let  $\gamma$  be any geodesic loop in  $S$  such that  $\gamma$  and  $\mathcal{T}_g$  have nonempty intersection. The existence of such a loop is guaranteed by Lemma 1.3.3. Replacing  $\gamma$  with  $\gamma^{-1}$  if necessary, we may assume that  $w_\gamma \geq 1$ . Let  $\kappa$  be the maximum of lengths of  $\gamma_i$  with respect to the metric  $d_S$ .

Let  $\mu, L$  and  $C$  be the constants given by Lemma 1.3.4. Let  $\{t(j)\}$  be the sequence of integers given by Lemma 1.5.2. For each  $n$ , let  $\sigma_n$  be the spiral loop corresponding to the curve  $\gamma$  and the sequence  $\{t(j)\}$ . Let  $\rho_n$  be the double spiral of  $\sigma_n$ . Let  $\mathcal{L}$  be the family of lines that are lifts of loops of  $\mathcal{T}_g$  or boundary loops of  $S$ . Since  $\tilde{\rho}_n$  satisfies the hypotheses of Lemma 1.3.4, it is an  $(L, C)$ -quasigeodesic in  $\tilde{S}$ .

Let  $h_n$  be the homotopy class of loop  $\rho_n$  at the basepoint  $s_0$ . We first claim that  $d_{\tilde{S}}(\tilde{s}_0, h_n(\tilde{s}_0)) \succeq n^2 + w_\gamma^n$ . Indeed, let  $r$  be the minimum of lengths of  $c_i$  with respect to the metric  $d_S$ . By the construction of the spiral loop  $\sigma_n$  we have  $|\tilde{\sigma}_n| \geq r \sum_{j=1}^{nm} |t(j)|$ . By Lemma 1.5.2(3), we have  $|\tilde{\sigma}_n| \succeq n^2 + w_\gamma^n$ . It is obvious that  $|\tilde{\rho}_n| \succeq n^2 + w_\gamma^n$  because  $|\tilde{\rho}_n| \geq 2|\tilde{\sigma}_n|$ . Since  $\tilde{\rho}_n$  is an  $(L, C)$ -quasigeodesic, it follows that  $d_{\tilde{S}}(\tilde{s}_0, h_n(\tilde{s}_0)) \succeq n^2 + w_\gamma^n$ .

Furthermore, we have  $d(\tilde{x}_0, h_n(\tilde{x}_0)) \preceq n$  by Lemma 1.5.4. Therefore,  $n^2 + w_\gamma^n \preceq \Delta_H^G$  by Corollary 1.2.10. It follows that  $\Delta_H^G$  is at least quadratic. If the horizontal surface is not virtually embedded, then we may choose the geodesic loop  $\gamma$  in  $S$  such that  $w_\gamma > 1$  by Theorem 1.4.11. In this case  $w_\gamma$  is an exponential function, and  $w_\gamma^n \preceq \Delta_H^G$ .  $\square$

## 1.6 Upper Bound of Distortion

In this section, we will find the upper bound of the distortion of horizontal surface. The main theorem in this section is the following.

**Theorem 1.6.1.** *Let  $g: (S, s_0) \looparrowright (N, x_0)$  be a horizontal surface in a graph manifold  $N$ . Let  $G = \pi_1(N, x_0)$  and  $H = g_*(\pi_1(S, s_0))$ . Then the distortion  $\Delta_H^G$  is at most exponential. Furthermore, if the horizontal surface  $g$  is virtually embedded then  $\Delta_H^G$  is at most quadratic.*

**Definition 1.6.2.** Lift the JSJ decomposition of the simple graph manifold  $N$  to the universal cover  $\tilde{N}$ , and let  $\mathbf{T}_N$  be the tree dual to this decomposition of  $\tilde{N}$ . Lift the collection  $\mathcal{T}_g$  to the universal cover  $\tilde{S}$ . The tree dual to this decomposition of  $\tilde{S}$  will be denoted by  $\mathbf{T}_S$ . The map  $\tilde{g}$  induces a map  $\zeta: \mathbf{T}_S \rightarrow \mathbf{T}_N$ .

The following lemma plays an important role in the proof of Theorem 1.6.1.

**Lemma 1.6.3.** *Let  $F$  be a connected compact surface with non-empty boundary and  $\chi(F) < 0$ . Let  $M = F \times S^1$ . Let  $g: (B, b) \looparrowright (M, x)$  be a horizontal surface. Then each fiber in  $\tilde{M}$  intersects with  $\tilde{g}(\tilde{B})$  exactly at one point.*

*Proof.* According to Lemma 2.1 in [RW98], there exists a finite covering map  $p: B \times S^1 \rightarrow M$  and an embedding  $i: B \rightarrow B \times S^1$  given by  $i(x) = (x, 1)$  such that  $g = p \circ i$ . Let  $\tilde{i}: \tilde{B} \rightarrow \tilde{B} \times \mathbb{R}$  be the lift of  $i$  such that  $\tilde{i}(\tilde{b}) = (\tilde{b}, 0)$ . Let  $\phi: \tilde{B} \rightarrow B$  and  $\Psi: \tilde{F} \rightarrow F$  be the universal covering maps. Let  $\pi: \mathbb{R} \rightarrow S^1$  be the usual covering space. Since  $\tilde{B} \times \mathbb{R}$  and  $\tilde{F} \times \mathbb{R}$  both universal cover  $M$ , there exists a homeomorphism  $\omega: (\tilde{B} \times \mathbb{R}, (\tilde{b}, 0)) \rightarrow (\tilde{F} \times \mathbb{R}, \tilde{g}(\tilde{b}))$  such that  $(\Psi \times \pi) \circ \omega = p \circ (\phi \times \pi)$ . By the unique lifting property, we have  $\omega \circ \tilde{i} = \tilde{g}$ . It follows that  $\tilde{g}(\tilde{B}) = \omega(\tilde{B} \times \{0\})$ . Since  $\omega$  maps each fiber in  $\tilde{B} \times \mathbb{R}$  to a fiber in  $\tilde{F} \times \mathbb{R}$ . It follows that each fiber in  $\tilde{F} \times \mathbb{R}$  intersects  $\omega(\tilde{B} \times \{0\})$  exactly at one point.  $\square$

**Proposition 1.6.4.** *The map  $\zeta$  is bijective.*

*Proof.* A simplicial map between trees is bijective if is locally bijective. Thus it suffices to show that the map  $\zeta$  is locally injective and locally surjective (see [Sta83] for details).

Suppose by way of contradiction that  $\zeta$  is not locally injective. Then there exist three distinct blocks  $\tilde{B}_1$ ,  $\tilde{B}_2$  and  $\tilde{B}_3$  in  $\tilde{S}$  such that  $\tilde{B}_1 \cap \tilde{B}_2 \neq \emptyset$  and  $\tilde{B}_2 \cap \tilde{B}_3 \neq \emptyset$  such that the images  $\tilde{g}(\tilde{B}_1)$  and  $\tilde{g}(\tilde{B}_3)$  lie in the same block  $\tilde{M}_1$  of  $\tilde{M}$ . Let  $\tilde{M}_2$  denote the block containing the image  $\tilde{g}(\tilde{B}_2)$ . We denote  $\ell_1 = \tilde{B}_1 \cap \tilde{B}_2$  and  $\ell_3 = \tilde{B}_2 \cap \tilde{B}_3$ . We have  $\tilde{g}(\ell_1)$  and  $\tilde{g}(\ell_3)$  are subsets of the JSJ plane  $\tilde{T} = \tilde{M}_1 \cap \tilde{M}_2$ . Since the lines  $\ell_1$  and  $\ell_3$  are disjoint and the map  $\tilde{g}$  is an embedding, it follows that  $\tilde{g}(\ell_1)$  and  $\tilde{g}(\ell_3)$  are disjoint lines in the plane  $\tilde{T}$ . By Remark 1.4.17, any fiber in the plane  $\tilde{T}$  intersects  $\tilde{g}(\ell_1)$  and  $\tilde{g}(\ell_3)$  at distinct points. This contradicts with Lemma 1.6.3 because  $\tilde{g}(\ell_1)$  and  $\tilde{g}(\ell_3)$  are subsets of  $\tilde{g}(\tilde{B}_2)$ . Therefore,  $\zeta$  is locally injective.

By Lemma 1.6.3, the block  $\tilde{g}(\tilde{B})$  must intersect every fiber of the Seifert component  $\tilde{M}$  containing it. In particular,  $\tilde{g}(\tilde{B})$  intersects every JSJ plane adjacent to  $\tilde{M}$ . Therefore the map  $\zeta$  is locally surjective.  $\square$

The following corollary is a combination of Lemma 1.6.3 and Proposition 1.6.4.

**Corollary 1.6.5.** *Each fiber of  $\tilde{N}$  intersects with  $\tilde{g}(\tilde{S})$  in one point.*

**Remark 1.6.6.** Let  $G$  and  $H$  be finitely generated groups with generating sets  $\mathcal{A}$  and  $\mathcal{B}$  respectively. Let  $\phi: G \rightarrow H$  be a homomorphism. Then there exists a positive number  $L$  such that  $|\phi(g)|_{\mathcal{B}} \leq L|g|_{\mathcal{A}}$  for all  $g$  in  $G$ . Indeed, suppose that  $\mathcal{A} = \{g_1, g_2, \dots, g_n\}$  we define  $L = \max\{|\phi(g_i)|_{\mathcal{B}} \mid i = 1, 2, \dots, n\}$ . Since  $\phi$  is a homomorphism, it is not hard to see that  $|\phi(g)|_{\mathcal{B}} \leq L|g|_{\mathcal{A}}$  for all  $g \in G$ .

The following proposition shows that the distortion of a horizontal surface in a trivial Seifert manifold is linear.

**Proposition 1.6.7.** *Let  $F$  be a connected compact surface with non-empty boundary and  $\chi(F) < 0$ . Let  $g: (B, b) \looparrowright (M, x)$  be a horizontal surface where  $M = F \times S^1$ . Let  $H = g_*(\pi_1(B, b))$  and  $G = \pi_1(M, x)$ . Then  $H \hookrightarrow G$  is a quasi-isometric embedding.*

*Proof.* We first choose generating sets for  $\pi_1(B)$ ,  $\pi_1(F)$  and  $\pi_1(S^1)$ . The generating sets of  $\pi_1(F)$  and  $\pi_1(S^1)$  induce a generating set on  $\pi_1(M)$ . Let  $g_1: B \rightarrow F$  and  $g_2: B \rightarrow S^1$  be

the maps such that  $g = (g_1, g_2)$ . We have  $g_1: B \rightarrow F$  is a finite covering map because  $g$  is a horizontal surface in  $M$ . It follows that  $g_{1*}(\pi_1(B))$  is a finite index subgroup of  $\pi_1(F)$ . As a result,  $g_{1*}$  is an  $(L', 0)$ -quasi-isometry for some constant  $L'$ . Since  $g_* = (g_{1*}, g_{2*})$  we have  $|g_*(h)| \geq |g_{1*}(h)| \geq |h|/L'$  for all  $h \in \pi_1(B)$ . Applying Remark 1.6.6 to the homomorphism  $g_*$ , the constant  $L'$  can be enlarged so that we can show that  $g_*$  is an  $(L', 0)$ -quasi-isometric embedding.  $\square$

For the rest of this section, we fix  $g: (S, s_0) \looparrowright (N, x_0)$  a horizontal surface in a simple graph manifold  $N$ , the metric  $d$  which given by Remark 1.4.13, and the hyperbolic metric  $d_S$  on  $S$  which described in Section 1.5. By Remark 1.4.16, we also assume that for each curve  $c$  in  $\mathcal{T}_g$  then  $g(c)$  is a straight in the JSJ torus  $T$  where  $T$  is the JSJ torus such that  $g(c) \subset T$ . We define a metric  $d_{\tilde{g}(\tilde{S})}$  on  $\tilde{g}(\tilde{S})$  as the following: for any  $u = \tilde{g}(x)$  and  $v = \tilde{g}(y)$ , we define  $d_{\tilde{g}(\tilde{S})}(u, v) = d_{\tilde{S}}(x, y)$ . The following corollary follows by combining Proposition 1.6.7 with several earlier results, using the fact that  $S$  has only finitely many blocks, and  $N$  has only finitely many Seifert components.

**Corollary 1.6.8.** *There exist numbers  $L$  and  $C$  such that the following holds: For each block  $\tilde{B}$  in  $\tilde{S}$ , let  $\tilde{M} = \tilde{F} \times \mathbb{R}$  be the Seifert component of  $\tilde{N}$  such that  $\tilde{g}(\tilde{B}) \subset \tilde{M}$ . The map  $\tilde{g}|_{\tilde{B}}: \tilde{B} \rightarrow \tilde{M} = \tilde{F} \times \mathbb{R}$  can be expressed as a pair of maps  $\tilde{g}_1: \tilde{B} \rightarrow \tilde{F}$  and  $\tilde{g}_2: \tilde{B} \rightarrow \mathbb{R}$ . Then  $\tilde{g}_1$  and  $\tilde{g}|_{\tilde{B}}$  are  $(L, C)$ -quasi-isometric embeddings, and*

$$|\tilde{g}_2(u) - \tilde{g}_2(v)| \leq L d_M(\tilde{g}_1(u), \tilde{g}_1(v)) + C$$

for all  $u, v \in \tilde{B}$ .

*Proof.* The map  $g|_B: B \rightarrow F \times S^1$  can be written as  $(g_1, g_2)$ . Since the map  $g_1: B \rightarrow F$  is a finite covering map, the lift  $\tilde{g}_1$  is a quasi-isometry. It follows from Proposition 1.6.7 that  $\tilde{g}|_{\tilde{B}}$  is a quasi-isometric embedding. The facts  $\tilde{g}_1$  and  $\tilde{g}|_{\tilde{B}}$  are quasi-isometrically embedded imply the final claim.  $\square$

Now, we describe informally the strategy of the proof of Theorem 1.6.1 in the case  $N$  is a simple graph manifold. For each  $n \in \mathbb{N}$ , let  $u \in \tilde{g}(\tilde{S})$  such that  $d(\tilde{x}_0, u) \leq n$ . We would like to find an upper bound (either quadratic or exponential as appropriate) for  $d_{\tilde{g}}(\tilde{x}_0, u)$  in terms of  $n$ . We first show the existence of a path  $\xi$  in  $\tilde{N}$  connecting  $\tilde{x}_0$  to  $u$  and passing through  $k$  Seifert components  $\tilde{M}_0, \dots, \tilde{M}_{k-1}$  such that  $\xi$  intersects the plane  $\tilde{T}_i = \tilde{M}_{i-1} \cap \tilde{M}_i$  at exactly one point, denoted by  $y_i$ . We will show that  $k$  is bounded above by a linear function of  $n$ . Therefore it suffices to find an upper bound for  $d_{\tilde{g}}(\tilde{x}_0, u)$  in terms of  $k$ . Let  $d_i$  be the given product metric on  $\tilde{M}_i$ . By Corollary 1.6.5 the fiber of  $\tilde{M}_{i-1}$  passing through  $y_i$  intersects  $\tilde{g}(\tilde{S})$  in a unique point which is denoted by  $x_i$ . Similarly, the fiber of  $\tilde{M}_i$  passing through  $y_i$  intersects  $\tilde{g}(\tilde{S})$  in one point which is denoted by  $z_i$ .

On the one hand, proving that the distance in  $\tilde{g}(\tilde{S})$  between the endpoints of  $\xi$  is dominated by the sum  $\sum_{i=1}^{k-1} (d_{i-1}(y_i, x_i) + d_i(y_i, z_i))$  is easy. On the other hand, finding a quadratic or exponential upper bound for this sum as a function of  $k$  requires more work. Our strategy is to analyze the growth of the sequence of numbers

$$\begin{aligned}
& d_0(y_1, x_1), d_1(y_1, z_1), d_1(y_2, x_2), \dots, \\
& \quad d_{i-2}(y_{i-1}, x_{i-1}), d_{i-1}(y_{i-1}, z_{i-1}), d_{i-1}(y_i, x_i), \dots, \\
& \quad \quad \quad d_{k-2}(y_{k-1}, x_{k-1}), d_{k-1}(y_{k-1}, z_{k-1})
\end{aligned}$$

A relation between  $d_{i-1}(y_{i-1}, z_{i-1})$  and  $d_{i-1}(y_i, x_i)$  in the Seifert component  $\tilde{M}_{i-1}$  will be described in Lemma 1.6.9. The ratio of  $d_{i-1}(y_{i-1}, z_{i-1})$  to  $d_{i-2}(y_{i-1}, x_{i-1})$  in the JSJ plane  $\tilde{T}_{i-1}$  will be described in Lemma 1.6.10.

**Lemma 1.6.9** (Crossing a Seifert component). *There exists a positive constant  $L'$  such that the following holds: For each block  $\tilde{B}$  in  $\tilde{S}$ , let  $\tilde{M} = \tilde{F} \times \mathbb{R}$  be the Seifert component such that  $\tilde{g}(\tilde{B}) \subset \tilde{M}$ . Let  $d_M$  be the given product metric on  $\tilde{M}$ , and let  $\tilde{T}$  and  $\tilde{T}'$  be two disjoint JSJ planes in the Seifert component  $\tilde{M}$ . For any two points  $y \in \tilde{T}$  and  $y' \in \tilde{T}'$ , let  $\ell \subset \tilde{T}$  and  $\ell' \subset \tilde{T}'$  be the lines that project to the fiber  $S^1$  in  $M$  such that  $y \in \ell$  and  $y' \in \ell'$ . Let  $x$*

(resp.  $x'$ ) be the unique intersection point of  $\ell$  (resp.  $\ell'$ ) with  $\tilde{g}(\tilde{B}) \cap \tilde{M}$  given by Lemma 1.6.3.

Then

$$d_M(y', x') \leq d_M(y, x) + L' d_M(y, y')$$

*Proof.* Let  $\rho$  and  $K$  be the constants given by Remark 1.4.13 and Remark 1.4.14 respectively, and let  $D = \rho/K$ . Let  $L$  and  $C$  be the constants given by Corollary 1.6.8. Let  $L' = L + 2 + C/D$ .

Let  $a$  and  $b$  be the projection points of  $y$  and  $y'$  to  $\tilde{F}$  respectively. We write  $\tilde{g}|_{\tilde{B}} = (\tilde{g}_1, \tilde{g}_2)$  where  $\tilde{g}_1: \tilde{B} \rightarrow \tilde{F}$  and  $\tilde{g}_2: \tilde{B} \rightarrow \mathbb{R}$ . Since  $\tilde{g}|_{\tilde{B}}$  is an embedding map and  $x, x' \in \tilde{g}(\tilde{B})$ , there exist  $a', b' \in \tilde{B}$  such that  $\tilde{g}(a') = x$  and  $\tilde{g}(b') = x'$ . It follows that  $\tilde{g}_1(a') = a$  and  $\tilde{g}_1(b') = b$ . By Corollary 1.6.8 we have

$$|\tilde{g}_2(a') - \tilde{g}_2(b')| \leq L d_M(\tilde{g}_1(a'), \tilde{g}_1(b')) + C = L d_M(a, b) + C.$$

Since  $\rho \leq d(a, b) \leq K d_M(a, b)$ , it follows that  $D \leq d_M(a, b)$ . Therefore

$$|\tilde{g}_2(a') - \tilde{g}_2(b')| \leq (L + C/D)d_M(a, b) \leq (L + C/D)d_M(y, y').$$

With respect to the orientation of the factor  $\mathbb{R}$  of  $\tilde{M}$ , let  $\Delta(y, a)$  and  $\Delta(y', b)$  be the displacements of pairs of points  $(y, a)$  and  $(y', b)$  respectively. We would like to show that  $|\Delta(y, a) - \Delta(y', b)| \leq 2 d_M(y, y')$ . Indeed, let  $s$  and  $t$  be the real numbers such that  $y = (a, s)$  and  $y' = (b, t)$ . We note that  $\Delta(y, a) = -s$  if  $s \geq 0$  and  $\Delta(y, a) = s$  if  $s \leq 0$  as well as  $\Delta(y', b) = -t$  if  $t \geq 0$  and  $\Delta(y', b) = t$  if  $t \leq 0$ . Since  $d_M(a, b) \leq d_M(y, y')$ , it follows that  $|\Delta(y, a) - \Delta(y', b)| \leq 2d_M(y, y')$ . Moreover, we have that  $d_M(y, x) = |\tilde{g}_2(a') + \Delta(y, a)|$  and  $d_M(y', x') = |\tilde{g}_2(b') + \Delta(y', b)|$ . Therefore the previous inequalities imply

$$\begin{aligned} d_M(y', x') - d_M(y, x) &\leq |\tilde{g}_2(a') - \tilde{g}_2(b')| + |\Delta(y, a) - \Delta(y', b)| \\ &\leq (L + 2 + C/D)d_M(y, y') = L' d_M(y, y'). \end{aligned} \quad \square$$

**Lemma 1.6.10** (Crossing a JSJ plane). *Let  $\tilde{M}$  and  $\tilde{M}'$  be the two adjacent Seifert components. Let  $d_M$  and  $d_{M'}$  be the given product metrics on  $\tilde{M}$  and  $\tilde{M}'$  respectively. Let  $\tilde{T} = \tilde{M} \cap \tilde{M}'$ , and let  $\alpha \subset \tilde{g}(\tilde{S}) \cap \tilde{T}$  be the line such that  $\alpha$  universally covers a curve  $g(c)$  for some  $c$  in  $\mathcal{T}_g$ . We moreover assume that  $\alpha$  is a straight line in  $(\tilde{T}, d_M)$ . For any two points  $x$  and  $z$  in the line  $\alpha$ , let  $\overleftarrow{\ell} \subset (\tilde{T}, d_M)$  and  $\overrightarrow{\ell} \subset (\tilde{T}, d_{M'})$  be the Euclidean geodesics such that  $x \in \overleftarrow{\ell}$  and  $z \in \overrightarrow{\ell}$  and they project to fibers  $\overleftarrow{f} \subset \overleftarrow{T}$  and  $\overrightarrow{f} \subset \overrightarrow{T}$  respectively. Let  $y$  be the unique intersection point of  $\overleftarrow{\ell}$  and  $\overrightarrow{\ell}$ . Let  $a$  and  $b$  be the integers such that*

$$[g(c)] = a[\overleftarrow{f}] + b[\overrightarrow{f}] \quad \text{in } H_1(T; \mathbb{Z}).$$

where  $T$  is the JSJ torus obtained from gluing  $\overleftarrow{T}$  to  $\overrightarrow{T}$ . Then  $d_M(y, x) = |a/b| d_{M'}(y, z)$

*Proof.* Let  $\kappa$  be the positive constant such that length of the fiber  $\overrightarrow{f}$  with respect to the metric  $d_M$  equals to  $1/\kappa$ . Let  $\tilde{c}$  be a path lift of  $c$  such that  $\tilde{g}(\tilde{c}) \subset \alpha$ . Let  $x'$  and  $z'$  be the initial point and the terminal point of  $\tilde{g}(\tilde{c})$  respectively. Let  $\overleftarrow{\ell}'$  and  $\overrightarrow{\ell}'$  be the Euclidean geodesics in  $(\tilde{T}, d_M)$  and  $(\tilde{T}, d_{M'})$  respectively such that  $x' \in \overleftarrow{\ell}'$  and  $z' \in \overrightarrow{\ell}'$  and both lines  $\overleftarrow{\ell}'$  and  $\overrightarrow{\ell}'$  project to fibers in  $\overleftarrow{T}$  and  $\overrightarrow{T}$  respectively. Let  $y'$  be the unique intersection point of  $\overleftarrow{\ell}'$  and  $\overrightarrow{\ell}'$ . It was shown in the proof of Lemma 1.5.4 that  $d_M(y', x') = |a|$  and  $d_{M'}(y', z') = |b|$ . By the definition of  $\kappa$ , it follows that  $d_{M'}(y', z') = \kappa d_M(y', z')$ .

In the Euclidean plane  $(\tilde{T}, d_M)$ , consider the similar triangles  $\Delta(x, y, z)$  and  $\Delta(x', y', z')$ . Since  $d_M(y, x)/d_M(y, z) = d_M(y', x')/d_M(y', z') = \kappa |a/b|$ , it follows that

$$d_M(y, x) = |a/b| \kappa d_M(y, z) = |a/b| d_{M'}(y, z)$$

.

□

*Proof of Theorem 1.6.1.* We may assume that  $N$  is a simple graph manifold for the same reason as in the first paragraph of the proof of Theorem 1.5.1. Let  $K$  be the constant given by Remark 1.4.13. Let  $L$  and  $C$  be the constants given by Corollary 1.6.8. Moreover, the

constant  $L$  can be enlarged so that  $L \geq K$  and  $L$  is greater than the constant  $L'$  given by Lemma 1.6.9. Moreover, we assume that the base point  $s_0$  belongs to a curve in the collection  $\mathcal{T}_g$ .

For any  $h \in \pi_1(S, s_0)$  such that  $d(\tilde{x}_0, h(\tilde{x}_0)) \leq n$ . We will show that  $d_{\tilde{S}}(\tilde{s}_0, h(\tilde{s}_0))$  is bounded above by either a quadratic or exponential function in term of  $n$ . The theorem is confirmed by an application of Corollary 1.2.10. We consider the following cases:

**Case 1:** The points  $\tilde{s}_0$  and  $h(\tilde{s}_0)$  belong to the same block  $\tilde{B}$ . In this degenerate case, we will show that  $d_{\tilde{S}}(\tilde{s}_0, h(\tilde{s}_0)) \preceq n$ . Indeed, let  $\tilde{M}$  be the Seifert component such that  $\tilde{g}(\tilde{B}) \subset \tilde{M}$ . Let  $d_{\tilde{M}}$  be the given product metric on  $\tilde{M}$ . Since  $\tilde{g}|_{\tilde{B}}$  is an  $(L, C)$ -quasi-isometric embedding by Corollary 1.6.8, it follows that

$$d_{\tilde{g}(\tilde{B})}(\tilde{x}_0, h(\tilde{x}_0)) \leq Ld_{\tilde{M}}(\tilde{x}_0, h(\tilde{x}_0)) + C \leq L^2d(\tilde{x}_0, h(\tilde{x}_0)) + C \leq L^2n + C.$$

Therefore,

$$d_{\tilde{S}}(\tilde{s}_0, h(\tilde{s}_0)) = d_{\tilde{g}(\tilde{S})}(\tilde{x}_0, h(\tilde{x}_0)) \leq d_{\tilde{g}(\tilde{B})}(\tilde{x}_0, h(\tilde{x}_0)) \leq L^2n + C.$$

**Case 2:** The points  $\tilde{s}_0$  and  $h(\tilde{s}_0)$  belong to distinct blocks of  $\tilde{S}$ . Let  $\mathcal{L}$  be the family of lines in  $\tilde{S}$  that are lifts of curves of  $\mathcal{T}_g$ . Since we assume that  $s_0$  belongs to a curve in the collection  $\mathcal{T}_g$ , thus there are distinct lines  $\alpha$  and  $\alpha'$  in  $\mathcal{L}$  such that  $\tilde{s}_0 \in \alpha$  and  $h(\tilde{s}_0) \in \alpha'$ . Let  $e$  and  $e'$  be the non-oriented edges in the tree  $\mathbf{T}_S$  corresponding to the lines  $\alpha$  and  $\alpha'$  respectively. Consider the non backtracking path joining  $e$  to  $e'$  in the tree  $\mathbf{T}_S$ , with ordered vertices  $v_0, v_1, \dots, v_{k-1}$  where  $v_1$  is not a vertex on the edge  $e$  and  $v_{k-2}$  is not a vertex on the edge  $e'$ . Consider the corresponding vertices  $\zeta(v_0), \dots, \zeta(v_{k-1})$  of the tree  $\mathbf{T}_N$  (see Definition 1.6.2). We denote the Seifert components corresponding to the vertices  $\zeta(v_i)$  by  $\tilde{M}_i$  with  $i = 0, 1, \dots, k-1$ . We note that the Seifert components  $\tilde{M}_i$  are distinct because  $\zeta$  is injective by Proposition 1.6.4. Let  $d_i$  be the given product metric on the Seifert component  $\tilde{M}_i$ .

For convenience, relabel  $\tilde{x}_0$  by  $y_0$ , and  $h(\tilde{x}_0)$  by  $y_k$ . Let  $\gamma$  be a geodesic in  $(\tilde{N}, d)$  joining

$y_0$  to  $y_k$ . Replace the path  $\gamma$  by a new path  $\xi$ , described as follows. For  $i = 1, 2, \dots, k-1$ , let  $\tilde{T}_i = \tilde{M}_{i-1} \cap \tilde{M}_i$ , and let  $t_i = \sup\{t \in [0, 1] \mid \gamma(t) \in \tilde{T}_i\}$ . Let  $y_i = \gamma(t_i)$ . Let  $\xi_i$  be the geodesic segment in  $(\tilde{M}_i, d_i)$  joining  $y_i$  to  $y_{i+1}$ . Let  $\xi$  be the concatenation  $\xi_0 \xi_1 \cdots \xi_{k-1}$ . Since  $d_{i-1}(y_{i-1}, y_i) \leq L d(y_{i-1}, y_i)$ , it follows that  $|\xi| \leq L |\gamma| \leq Ln$ . Here  $|\cdot|$  denotes the length of a path with respect to the metric  $d$ .

For each  $i$ , let  $\overleftarrow{\ell}_i$  and  $\overrightarrow{\ell}_i$  be the Euclidean geodesics in  $(\tilde{T}_i, d_{i-1})$  and  $(\tilde{T}_i, d_i)$  passing through  $y_i$  such that they project to fibers  $\overleftarrow{f}_i \subset \overleftarrow{T}_i$  and  $\overrightarrow{f}_i \subset \overrightarrow{T}_i$  respectively. Let  $\alpha_i = \tilde{g}(\tilde{S}) \cap \tilde{T}_i$ . By Corollary 1.6.5, the lines  $\overleftarrow{\ell}_i$  and  $\overrightarrow{\ell}_i$  intersect  $\alpha_i$  at points, denoted by  $x_i$  and  $z_i$  respectively. Let  $\rho$  be the minimum distance between two distinct JSJ planes in  $\tilde{N}$  (see Remark 1.4.14).

**Claim 1:** There exists a linear function  $J$  not depending on the choices of  $n$ ,  $h$ , or  $\xi$  such that

$$d_{\tilde{g}(\tilde{S})}(y_0, y_k) \leq J\left(\sum_{i=1}^{k-1} d_i(y_i, z_i) + n\right).$$

Let  $z_0 = y_0$  and  $z_k = y_k$ . We first show that for each  $i = 0, \dots, k-1$  then

$$d_i(z_i, z_{i+1}) \leq L^2(d_i(z_i, y_i) + |\xi_i| + d_{i+1}(y_{i+1}, z_{i+1}))$$

Indeed,

$$\begin{aligned} d_i(z_i, z_{i+1}) &\leq d_i(z_i, y_i) + d_i(y_i, y_{i+1}) + d_i(y_{i+1}, z_{i+1}) \\ &\leq d_i(z_i, y_i) + L|\xi_i| + d_i(y_{i+1}, z_{i+1}) \\ &\leq d_i(z_i, y_i) + L|\xi_i| + Ld(y_{i+1}, z_{i+1}) \\ &\leq d_i(z_i, y_i) + L|\xi_i| + L^2d_{i+1}(y_{i+1}, z_{i+1}) \quad \text{because } L \geq 1 \\ &\leq L^2(d_i(z_i, y_i) + |\xi_i| + d_{i+1}(y_{i+1}, z_{i+1})) \end{aligned}$$

Using Corollary 1.6.8 we obtain

$$\begin{aligned}
d_{\bar{g}(\bar{S})}(y_0, y_k) &\leq \sum_{i=0}^{k-1} d_{\bar{g}(\bar{S})}(z_i, z_{i+1}) \leq \sum_{i=0}^{k-1} Ld_i(z_i, z_{i+1}) + kC \\
&\leq 2L^3 \sum_{i=0}^k d_i(z_i, y_i) + L^3|\xi| + kC \\
&= 2L^3 \sum_{i=1}^{k-1} d_i(z_i, y_i) + L^3|\xi| + kC
\end{aligned}$$

Since  $d(\tilde{x}_0, h(\tilde{x}_0)) \leq n$ , it follows that  $k\rho \leq n$ , and therefore  $k \leq n/\rho$ . We note that  $|\xi| \leq Ln$ .

Letting  $A = \max\{2L^3, L^4 + C/\rho\}$ , and  $J(x) = Ax$ , Claim 1 is confirmed.

In order to complete the proof, it suffices to find an appropriate upper bound for the sum appearing in the conclusion of Claim 1. In the general case, we need an exponential upper bound, but in the special case of trivial dilation we require a quadratic upper bound.

By Lemma 1.6.9 we immediately see

$$d_{i-1}(y_i, x_i) \leq d_{i-1}(y_{i-1}, z_{i-1}) + L^2|\xi_{i-1}|. \quad (*)$$

Observe that  $\alpha_i$  universally covers a closed curve  $g(c_i) \in T_i$  for some  $c_i \in \mathcal{T}_g$  and  $[g(c_i)] = a_i [\overleftarrow{f_i}] + b_i [\overrightarrow{f_i}]$  in  $H_1(T_i; \mathbb{Z})$  for some  $a_i, b_i \in \mathbb{Z}$ . By Lemma 1.6.10, we conclude that

$$d_i(y_i, z_i) = |b_i/a_i| d_{i-1}(y_i, x_i). \quad (\dagger)$$

**Claim 2:** Suppose  $g$  is not virtually embedded. There exists a function  $F$  not depending on the choices of  $n, h$ , or  $\xi$  such that

$$\sum_{j=1}^{k-1} d_j(y_j, z_j) \leq F(n)$$

and  $F(n) \sim 2^n$ .

Since  $g$  is not virtually embedded, the governor  $\epsilon = \epsilon(g)$ , defined in Remark 1.4.14, must

be strictly greater than 1. We will show by induction on  $j = 0, \dots, k-1$  that

$$d_j(y_j, z_j) \leq L^3 n \sum_{i=1}^j \epsilon^i$$

The base case of  $j = 0$  is trivial since  $y_0 = z_0$ , so both sides of the inequality equal zero. For the inductive step, we use  $(*)$ ,  $(\dagger)$ , and the facts  $|\xi_{j-1}| \leq Ln$  and  $|b_j/a_j| \leq \epsilon$  to see that

$$\begin{aligned} d_j(y_j, z_j) &= |b_j/a_j| d_{j-1}(y_j, x_j) \\ &\leq \epsilon d_{j-1}(y_j, x_j) \\ &\leq \epsilon (d_{j-1}(y_{j-1}, z_{j-1}) + L^2 |\xi_{j-1}|) \\ &\leq \epsilon d_{j-1}(y_{j-1}, z_{j-1}) + \epsilon L^3 n \\ &\leq \epsilon (\epsilon + \epsilon^2 + \dots + \epsilon^{j-1}) L^3 n + \epsilon L^3 n \\ &\leq (\epsilon + \epsilon^2 + \dots + \epsilon^j) L^3 n. \end{aligned}$$

Summing this geometric series gives

$$d_j(y_j, z_j) \leq \frac{L^3 n}{\epsilon - 1} \epsilon^{j+1}.$$

Summing a second time over  $j$ , we obtain

$$\sum_{j=1}^{k-1} d_j(y_j, z_j) \leq \frac{L^3 n}{\epsilon - 1} (\epsilon^2 + \dots + \epsilon^k) \leq \frac{\epsilon L^3}{(\epsilon - 1)^2} n \epsilon^k \leq \frac{\epsilon L^3}{(\epsilon - 1)^2} n \epsilon^{n/\rho}$$

which is equivalent to an exponential function of  $n$ , establishing Claim 2. (Recall that for any polynomial  $p(n)$ , we have  $p(n)2^n \leq 2^n 2^n = 2^{2n}$  for sufficiently large  $n$ .)

**Claim 3:** Assume that  $g$  is virtually embedded. There exists a quadratic function  $Q$  not

depending on the choices of  $n$ ,  $h$ , or  $\xi$  such that

$$\sum_{j=1}^{k-1} d_j(y_j, z_j) \leq Q(n).$$

For any  $1 \leq i \leq j$ , let

$$\Theta_{i,j} = \left| \frac{b_i}{a_i} \right| \cdot \left| \frac{b_{i+1}}{a_{i+1}} \right| \cdots \left| \frac{b_j}{a_j} \right|$$

Let  $\Lambda$  be the constant given by Proposition 1.4.15. In order to prove Claim 3, we mimic the argument of Claim 2—using  $\Theta_{i,j}$  in place of the terms of the form  $\epsilon^\ell$ . This change gives tighter results than those obtained in Claim 2, since  $\Theta_{i,j}$  is bounded above by the constant  $\Lambda$ . This upper bound applies only in the virtually embedded case, as explained in Proposition 1.4.15. The key recursive property satisfied by  $\Theta_{i,j}$  is the following:

$$\Theta_{i,j-1} \left| \frac{b_j}{a_j} \right| = \Theta_{i,j}.$$

We will show by induction on  $j = 0, \dots, k-1$  that

$$d_j(y_j, z_j) \leq L^2 \sum_{i=1}^j |\xi_{i-1}| \Theta_{i,j}$$

As before, the base case  $j = 0$  is trivial. For the inductive step, we use  $(\dagger)$  and  $(*)$  to see

that

$$\begin{aligned}
d_j(y_j, z_j) &= d_{j-1}(y_j, x_j) |b_j/a_j| \\
&\leq (d_{j-1}(y_{j-1}, z_{j-1}) + L^2 |\xi_{j-1}|) |b_j/a_j| \\
&= d_{j-1}(y_{j-1}, z_{j-1}) |b_j/a_j| + L^2 |\xi_{j-1}| |b_j/a_j| \\
&\leq \left( L^2 \sum_{i=1}^{j-1} |\xi_{i-1}| \Theta_{i,j-1} \right) |b_j/a_j| + L^2 |\xi_{j-1}| |b_j/a_j| \\
&= L^2 \sum_{i=1}^{j-1} |\xi_{i-1}| \Theta_{i,j} + L^2 |\xi_{j-1}| \Theta_{j,j} \\
&= L^2 \sum_{i=1}^j |\xi_{i-1}| \Theta_{i,j}
\end{aligned}$$

Since  $\Theta_{i,j}$  is bounded above by  $\Lambda$ , and  $\sum_{i=1}^j |\xi_{i-1}| \leq |\xi| \leq Ln$ , we have

$$d_j(y_j, z_j) \leq L^2 \sum_{i=1}^j |\xi_{i-1}| \Theta_{i,j} \leq \Lambda L^3 n.$$

Summing over  $j$ , we obtain

$$\sum_{j=1}^{k-1} d_j(y_j, z_j) \leq (k-1) \Lambda L^3 n \leq \left( \frac{n}{\rho} - 1 \right) \Lambda L^3 n$$

which is a quadratic function of  $n$ , establishing Claim 3.

If  $g$  is not virtually embedded, we combine Claim 1 and Claim 2 to get an exponential upper bound for  $d_{\tilde{g}(\tilde{S})}(y_0, y_k)$ . In the virtually embedded case, we combine Claim 1 and Claim 3 to get a quadratic upper bound. The theorem now follows from Corollary 1.2.10.  $\square$

## 1.7 Fiber surfaces have quadratic distortion

In this section we show in detail how results of Gersten and Kapovich–Leeb [Ger94, KL98] can be combined with Thurston’s geometric description of 3–manifolds that fiber over the circle

to prove Theorem 1.1.4. This section is an elaboration of ideas that are implicitly used by Kapovich–Leeb in [KL98] but not stated explicitly there. As explained in the introduction, Theorem 1.1.4 is the main step in an alternate proof of the virtually embedded case of Theorem 1.1.2.

The following theorem relates distortion of normal subgroups to the notion of divergence of groups. Roughly speaking, divergence is a geometric invariant that measures the circumference of a ball of radius  $n$  as a function of  $n$ . (See [Ger94] for a precise definition.)

**Theorem 1.7.1** ([Ger94], Thm. 4.1). *If  $G = H \rtimes_{\phi} \mathbb{Z}$ , where  $G$  and  $H$  are finitely generated, then the divergence of  $G$  is dominated by the distortion  $\Delta_H^G$ .*

Let  $H$  be generated by a finite set  $\mathcal{T}$ . An automorphism  $\phi \in \text{Aut}(H)$  has *polynomial growth* of degree at most  $d$  if there exist constants  $\alpha, \beta$  such that

$$|\phi^i(t)|_{\mathcal{T}} \leq \alpha n^d + \beta$$

for all  $t \in \mathcal{T}$  and all  $i$  with  $|i| \leq n$ .

Gersten claims the following result in the case that  $H$  is a free group. However his proof uses only that  $H$  is finitely generated, so we get the following result using the same proof.

**Theorem 1.7.2** ([Ger94], Prop. 4.2). *If  $G = H \rtimes_{\phi} \mathbb{Z}$ , where  $G$  and  $H$  are finitely generated and  $\phi \in \text{Aut}(H)$  has polynomial growth of degree at most  $d$ , then  $\Delta_H^G \preceq n^{d+1}$ .*

*Proof of Theorem 1.1.4.* Let  $N$  be a graph manifold that fibers over  $S^1$  with surface fiber  $S$ . Then  $N$  is the mapping torus of a homeomorphism  $f \in \text{Aut}(S)$ . In particular, if we let  $G = \pi_1(N)$  and  $H = \pi_1(S)$ , then  $G = H \rtimes_{\phi} \mathbb{Z}$ , where  $\phi \in \text{Aut}(H)$  is an automorphism induced by  $f$ . Passing to finite covers, we may assume without loss of generality that  $N$  and  $S$  are orientable and that the map  $f$  is orientation preserving.

Kapovich–Leeb show that the divergence of the fundamental group of any graph manifold is at least quadratic [KL98, §3]. Therefore by Theorem 1.7.1 the distortion of  $H$  in  $G$  is also at least quadratic.

By Theorem 1.7.2, in order to establish a quadratic upper bound for  $\Delta_H^G$ , it suffices to show that  $\phi$  has linear growth. We will first apply the Nielsen–Thurston classification of surface homeomorphisms to the map  $f$  (see, for example, Corollary 13.2 of [FM12]). By the Nielsen–Thurston theorem, there exists a multicurve  $\{c_1, \dots, c_k\}$  with the following properties. The curves  $c_i$  have disjoint closed annular neighborhoods  $S_1, \dots, S_k$ . Let  $S_{k+1}, \dots, S_{k+\ell}$  be the closures of the connected components of  $S - \bigcup_{i=1}^k S_i$ . Then there is a map  $g$  isotopic to  $f$  and a positive number  $m$  such that  $g^m$  leaves each subsurface  $S_i$  invariant. Furthermore  $g^m$  is a product of homeomorphisms  $g_1 \cdots g_{k+\ell}$  such that each  $g_i$  is supported on  $S_i$ . For  $i = 1, \dots, k$ , the map  $g_i$  (supported on the annulus  $S_i$ ) is a power of a Dehn twist about  $c_i$ . For  $i = k + 1, \dots, k + \ell$ , each  $g_i$  is either the identity or a map that restricts to a pseudo-Anosov map of  $S_i$ .

Consider the mapping torus  $\hat{N}$  for the homeomorphism  $g^m$  of  $S$ , which finitely covers  $N$ . Apply Thurston’s geometric classification of mapping tori to  $\hat{N}$  to conclude that the family of tori  $c_i \times S^1$  in the mapping torus  $\hat{N}$  is equal to the family of JSJ tori of  $\hat{N}$ . It follows that for each  $i = k + 1, \dots, k + \ell$  the map  $g_i$  is equal to the identity on  $S$ . Indeed if any  $g_i$  were pseudo-Anosov, then the corresponding JSJ component of  $\hat{N}$  would be atoroidal and hyperbolic, which is impossible in a graph manifold.

Therefore  $g^m$  is a product of powers of Dehn twists about disjoint curves. In particular the automorphism  $\phi^m$  has linear growth. Clearly  $\phi$  itself must also have linear growth. Therefore the distortion of  $H$  in  $G$  is at most quadratic as desired.  $\square$

# Chapter 2

## Distortion of surfaces in 3-manifolds

### 2.1 Introduction

In geometric group theory, the distortion of a finitely generated subgroup  $H$  in a finitely generated subgroup  $G$  is a classical notion. Let  $\mathcal{S}$  and  $\mathcal{A}$  be finite generating sets of  $G$  and  $H$  respectively. The subgroup  $H$  itself admits a word length metric, but it also inherits an induced metric from the group  $G$ . The distortion of  $H$  in  $G$  compares these metrics on  $H$ . In other words, we would like to know how the inclusion  $H \hookrightarrow G$  preserves geometric properties of  $H$ . More precisely, the *distortion* of  $H$  in  $G$  is the function

$$\Delta_H^G(n) = \max\{ |h|_{\mathcal{A}} \mid h \in H \text{ and } |h|_{\mathcal{S}} \leq n \}$$

Up to a natural equivalence, the function  $\Delta_H^G$  does not depend on the choice of finite generating sets  $\mathcal{S}$  and  $\mathcal{A}$ . This chapter is devoted to understanding the large scale geometry of immersed surfaces in 3-manifolds by using distortion of the surface group. In fact, the purpose is to address the following problem:

**Problem 2.1.1.** Let  $S \looparrowright N$  be a properly immersed  $\pi_1$ -injective surface in a 3-manifold  $N$ . What is the distortion of  $\pi_1(S)$  in  $\pi_1(N)$ ? How does it relate to algebraic properties of  $\pi_1(S) \leq \pi_1(N)$ , topological properties of the immersion and geometries of components in

the JSJ decomposition?

Dani Wise observed that Problem 2.1.1 is important in the study of cubulations of 3-manifold groups. The goal of cubulation is to find a suitable collection of immersed surfaces and then study the action of the fundamental group of the 3-manifold on the CAT(0) cube complex dual to the collection of immersed surfaces. Whenever the fundamental group acts properly and cocompactly, surfaces must be undistorted.

A compact, orientable, irreducible 3-manifold  $N$  with empty or toroidal boundary is *geometric* if its interior admits a geometric structure in the sense of Thurston. The answer to Problem 2.1.1 is relatively well-understood in the geometric case. By Hass [Has87], if  $N$  is a Seifert fibered space then up to homotopy, the surface  $S$  is either vertical (i.e, union of fibers) or horizontal (i.e, tranverses to fibers). In either case,  $\pi_1(S)$  is undistorted in  $\pi_1(N)$ . If  $N$  is a hyperbolic 3-manifold, then by Bonahon-Thurston ([Bon86], [Thu79]) the distortion is linear when the surface is geometrically finite and the distortion is exponential when the surface is geometrically infinite.

By Geometrization Theorem, a non-geometric 3-manifold can be cut into hyperbolic and Seifert fibered “blocks” along a JSJ decomposition. It is called a *graph manifold* if all the blocks are Seifert fibered, otherwise it is a *mixed manifold*.

An immersed surface  $S$  in a non-geometric manifold  $N$  is called *properly immersed* if the preimage of  $\partial N$  under the immersion is  $\partial S$ . Roughly speaking, if the surface  $S$  is properly immersed  $\pi_1$ -injective in the non-geometric manifold  $N$  then up to homotopy, the JSJ decomposition in the manifold into blocks induces a decomposition on the surface into *pieces*. Each piece is carried in either a hyperbolic or Seifert fibered block. A piece in a Seifert fibered block is either vertical or horizontal, and a piece in a hyperbolic block is either geometrically finite or geometrically infinite. Yi Liu [Liu17] and Hongbin Sun [Sun] show that all information about virtual embedding can be obtained by examining the *almost fiber part*  $\Phi(S)$ , that is, the union of horizontal and geometrically infinite pieces. We remark that virtual embedding is equivalent to subgroup separability [Sco78], [PW14b] (a subgroup

$H \leq G$  is called *separable* if for any  $g \in G - H$  there exists a finite index subgroup  $K \leq G$  such that  $H \leq K$  and  $g \notin K$ ).

The following theorem is the main theorem in this paper which give a complete answer to Problem 2.1.1. The theorem states for “clean surfaces” which we discuss below, but we emphasize here that up to homotopy every properly immersed surface is also a clean surface.

**Theorem 2.1.2** (Distortion of surfaces in non-geometric 3-manifolds). *Let  $g: S \looparrowright N$  be a clean surface in a non-geometric 3-manifold  $N$ . Suppose that all Seifert fibered blocks of  $N$  are non-elementary. Let  $\Delta$  be the distortion of  $\pi_1(S)$  in  $\pi_1(N)$ . There are four mutually exclusive cases:*

1. *If there is a component  $S'$  of the almost fiber  $\Phi(S)$  such that  $S'$  contains a geometrically infinite piece and  $\pi_1(S')$  is non-separable in  $\pi_1(N)$  then  $\Delta$  is double exponential.*
2. *Suppose that  $\phi(S)$  has no component satisfying (1). If there is a component  $S'$  of the almost fiber  $\Phi(S)$  such that  $S'$  contains a geometrically infinite piece then  $\Delta$  is exponential.*
3. *Suppose that  $\phi(S)$  has no component satisfying (1) and (2) (i.e, no component of  $\phi(S)$  contains a geometrically infinite piece). If there is a component of the almost fiber  $\Phi(S)$  containing two adjacent pieces then  $\Delta$  is exponential if  $\pi_1(S)$  is non-separable in  $\pi_1(N)$  and  $\Delta$  is quadratic if  $\pi_1(S)$  is separable in  $\pi_1(N)$ .*
4. *In all other cases,  $\Delta$  is linear.*

We note that Theorem 2.1.2 generalizes the main theorem of Hruska-Nguyen in Chapter 1. In the setting of a properly immersed surface in a graph manifold, Hruska and the author (Chapter 1) show that when the surface is an almost fiber, i.e, horizontal, its distortion is always nontrivial. The distortion is quadratic if the fundamental group of the surface is separable in the fundamental group of the manifold and the distortion is exponential otherwise.

For the definition of nonelementary Seifert fibered space, we refer the reader to Section 2.3. We note that the properly immersed condition of a surface is not general enough for the purpose of this paper since the almost fiber part  $\Phi(S)$  is no longer a properly immersed surface in the 3-manifold (in fact, it is typical that a boundary circle of the almost fiber part is mapped into a JSJ torus of  $N$ ). We thus introduce the notion of *clean surfaces* which generalizes the notion of properly immersed surfaces by allowing some boundary circles to be mapped into JSJ tori (see Definition 2.3.8). Clean surfaces are general enough for the purpose of computing distortion in this paper (as the almost fiber part of a clean surface is again a clean surface and a properly immersed  $\pi_1$ -injective surface is also a clean surface).

We prove Theorem 2.1.2 by using the following strategy. We prove that the distortion of a clean surface  $S$  in a non-geometric 3-manifold  $N$  depends only on the almost fiber part  $\Phi(S)$  (see Theorem 2.1.3) and then we compute the distortion of components of the almost fiber part  $\Phi(S)$  in the manifold  $N$  (see Theorem 2.1.5 and Theorem 2.1.4).

**Theorem 2.1.3.** *Let  $g: S \looparrowright N$  be a clean surface in a non-geometric 3-manifold  $N$ . We assume that every Seifert fibered block in  $N$  is nonelementary. For each component  $S_i$  of  $\Phi(S)$ , let  $\delta_{S_i}$  be the distortion of  $\pi_1(S_i)$  in  $\pi_1(N)$ . Then the distortion of  $H = \pi_1(S)$  in  $G = \pi_1(N)$  satisfies*

$$f \preceq \Delta_H^G \preceq \bar{f}$$

where

$$f(n) := \max\{ \delta_{S_i}(n) \mid S_i \text{ is a component of } \Phi(S) \}$$

and  $\bar{f}$  is the superadditive closure of  $f$ .

For the definition of superadditive closure function, we refer the reader to Section 2.2. We remark that a similar result was proved by Hruska for relatively hyperbolic groups (see Theorem 1.4 in [Hru10]), but the conclusion here is stronger because in many cases  $\pi_1(S)$  and  $\pi_1(N)$  don't satisfy the hypothesis in Theorem 1.4 [Hru10].

In [RW98], Rubinstein-Wang introduce a combinatorial invariant called ‘‘spirality’’ and

show that it is the obstruction to separability for horizontal surfaces in graph manifolds. Recently, Liu [Liu17] generalizes the work of Rubinstein–Wang to closed surfaces in closed non-geometric 3–manifolds and Sun [Sun] generalizes the work of Liu to arbitrary finitely generated subgroups in arbitrary non-geometric 3–manifolds. In the setting of a clean almost fiber surface in a graph manifold, the following theorem follows immediately from the work of Hruska–Nguyen in Chapter 1 and the theorems of Liu [Liu17] and Sun [Sun].

**Theorem 2.1.4.** *Let  $S \looparrowright N$  be a clean almost fiber surface (i.e.,  $\Phi(S) = S$ ) in a graph manifold  $N$ . We assume that all Seifert fibered blocks of  $N$  is non-elementary. Let  $\Delta$  be the distortion of  $\pi_1(S)$  in  $\pi_1(N)$ . Then*

1.  $\Delta$  is linear if each component of the almost fiber part contains only one horizontal piece.
2. Otherwise,  $\Delta$  is quadratic if  $\pi_1(S)$  is separable in  $\pi_1(N)$ , and exponential if  $\pi_1(S)$  is non-separable in  $\pi_1(N)$ .

To give a complete proof to Theorem 2.1.2, it remains to compute the distortion of a clean almost fiber surface in a mixed manifold (see Theorem 2.1.5). This computation is one of the main components of this paper. We note that a fibered 3–manifold can be expressed as a mapping torus for a diffeomorphism of the fiber surface. The strategy in the proof of Theorem 2.1.5 is inspired from Hruska–Nguyen (Chapter 1) and Woodhouse [Woo16]. However the techniques are different because unlike the setting of a Seifert block where the diffeomorphism of the fiber surface is trivial and the distortion of the fiber surface in the Seifert block is linear, the diffeomorphism of the fiber surface in a hyperbolic block is pseudo-Anosov and the distortion of the fiber surface in the hyperbolic block is exponential. In addition, the generalized definition of spirality by Liu and Sun in a mixed manifold is more elaborate. We use the generalization of Liu and Sun to compute the distortion and show that the distortion is determined by separability of the surface subgroup.

**Theorem 2.1.5.** *Let  $S \looparrowright N$  be a clean almost fiber surface (i.e.,  $\Phi(S) = S$ ) in a mixed manifold  $N$ . We assume that all Seifert fibered blocks of  $N$  is non-elementary. Suppose that  $S$  contains at least one geometrically infinite piece. Then the distortion of  $\pi_1(S)$  in  $\pi_1(N)$  is exponential if  $\pi_1(S)$  is separable in  $\pi_1(N)$ , and double exponential if  $\pi_1(S)$  is non-separable in  $\pi_1(N)$ .*

As mentioned above, the strategy for constructing an action of  $\pi_1(N)$  on a CAT(0) cube complex is to find a suitable collection of immersed surfaces and then consider the CAT(0) cube complex dual to this collection of surfaces. According to Hagen–Przytycki [HP15] and Tidmore [Tid] the fundamental groups of chargeless graph manifolds and chargeless mixed manifolds act cocompactly on CAT(0) cube complexes. The cubulations constructed by them are each dual to a collection of immersed surfaces, none of which contains a geometrically infinite piece or two adjacent horizontal pieces. It is clear from the corollary below that the cocompact cubulations of Hagen–Przytycki and Tidmore are canonical. For the purpose of obtaining a proper, cocompact cubulation, all surface subgroups must be of the type used by Hagen–Przytycki and Tidmore.

**Corollary 2.1.6.** *Let  $G$  be the fundamental group of a non-geometric 3-manifold. Let  $\{H_1, H_2, \dots, H_k\}$  be a collection of codimension-1 subgroups of  $G$ . Let  $X$  be the corresponding dual CAT(0) cube complex. If at least one  $H_i$  is the fundamental group of a surface containing two adjacent horizontal pieces or a geometrically infinite piece, then the action of  $G$  on  $X$  is not proper and cocompact.*

### 2.1.1 Overview

In Section 2.2 we review some concepts in geometric group theory. Section 2.3 is a review background about 3-manifolds and introduced the notion of clean surface. In Section 2.4, we give the proof of Theorem 2.1.3. The proof of Theorem 2.1.5 is given in Section 2.5. In Section 2.6, we discuss about Theorem 2.1.4 and Theorem 2.1.2 by combining previous results.

## 2.2 Preliminaries

In this section, we review some concepts in geometric group theory.

The following propositions is routine, and we leave the proof as an exercise for the reader.

**Proposition 2.2.1.** *Let  $K', K$  and  $G'$  be finitely generated subgroups of a finitely generated group  $G$  such that  $K' \leq G'$  and  $K' \leq K$ . Suppose that  $K'$  is undistorted in  $K$  and  $G'$  is undistorted in  $G$ . Then  $\Delta_{K'}^{G'} \preceq \Delta_K^G$ .*

**Proposition 2.2.2.** *Let  $G, H, K$  be finitely generated groups with  $K \leq H \leq G$ .*

1. *If  $H$  is a finite index subgroup of  $G$  then  $\Delta_K^H \sim \Delta_K^G$ .*

2. *If  $K$  is a finite index subgroup of  $H$  then  $\Delta_K^G \sim \Delta_H^G$ . □*

**Lemma 2.2.3** (Proposition 9.4 [Hru10]). *Let  $G$  be a finitely generated group with a word length metric  $d$ . Suppose  $H$  and  $K$  are subgroups of  $G$ . For each constant  $r$  there is a constant  $r' = r'(G, d, H, K)$  so that in the metric space  $(G, d)$  we have*

$$\mathcal{N}_r(H) \cap \mathcal{N}_r(K) \subset \mathcal{N}_{r'}(H \cap K)$$

**Definition 2.2.4.** A function  $f: \mathbb{N} \rightarrow \mathbb{N}$  is *superadditive* if

$$f(a + b) \geq f(a) + f(b) \text{ for all } a, b \in \mathbb{N}$$

The *superadditive closure* of a function  $f: \mathbb{N} \rightarrow \mathbb{N}$  is the function defined by the formula

$$\bar{f}(n) = \max\{f(n_1) + \cdots + f(n_\ell) \mid \ell \geq 1 \text{ and } n_1 + \cdots + n_\ell = n\}$$

**Remark 2.2.5.** The following facts are easy to verify. We leave it as an exercise to the reader.

1. Suppose that  $f_i \sim g_i$  with  $i = 1, \dots, \ell$ . Let  $f(n) = \max\{f_i(n) \mid i = 1, \dots, \ell\}$  and  $g(n) = \max\{g_i(n) \mid i = 1, \dots, \ell\}$ . Then  $f \sim g$ .
2. If  $f$  and  $g$  are superadditive and  $f \sim g$  then  $\bar{f} \sim \bar{g}$ .

## 2.3 Surfaces in non-geometric 3-manifolds

In this section, we review backgrounds of surfaces in 3-manifolds. Throughout this paper, a 3-manifold is always assumed to be compact, connected, orientable, irreducible with empty or toroidal boundary. A surface is always compact, connected and orientable and not a 2-sphere  $S^2$ .

**Definition 2.3.1.** Let  $M$  be a compact, orientable, irreducible 3-manifold with empty or toroidal boundary. The 3-manifold  $M$  is *geometric* if its interior admits a geometric structure in the sense of Thurston which are 3-sphere, Euclidean 3-space, hyperbolic 3-space,  $S^2 \times \mathbb{R}$ ,  $\mathbb{H}^2 \times \mathbb{R}$ ,  $\widetilde{SL}(2, \mathbb{R})$ , Nil and Sol. Otherwise,  $M$  is called *non-geometric*. By the Geometrization Theorem, a non-geometric 3-manifold can be cut into hyperbolic and Seifert fibered “blocks” along a JSJ decomposition. It is called a *graph manifold* if all the blocks are Seifert fibered, otherwise it is a *mixed manifold*. A Seifert fibered space is called *nonelementary* if it is a circle bundle over a hyperbolic 2-orbifold.

A non-geometric 3-manifold  $M$  always has a double cover in which all Seifert fibered blocks are nonelementary. In this section, we will always assume that all Seifert fibered blocks in a non-geometric 3-manifold are nonelementary.

**Definition 2.3.2.** Let  $M$  be a Seifert fibered space, and  $S \looparrowright M$  is a properly immersed  $\pi_1$ -injective surface. The surface  $S$  is called *horizontal* if it intersects transversely to the Seifert fibers, *vertical* if it is a union of the Seifert fibers.

The definition of geometrically finite surface below is one of many equivalent forms. We refer the reader to [Bow93] for detail discussions.

**Definition 2.3.3.** Let  $g: S \looparrowright M$  be a properly immersed  $\pi_1$ -injective surface in a hyperbolic 3-manifold  $M$ . The surface  $S$  is called *geometrically finite* if  $\pi_1(S)$  is undistorted subgroup of  $\pi_1(M)$ , *geometrically infinite* if  $S$  is not a geometrically finite surface.

**Definition 2.3.4.** A properly immersed  $\pi_1$ -injective surface  $g: S \looparrowright M$  is called *virtual fiber* if after applying a homotopy relative to boundary,  $g$  can be lifted to some finite cover  $M_S$  of  $M$  that fibers over the circle such that  $g$  lifts to a fiber. In fact,  $M_S$  is the mapping torus

$$M_S = \frac{S \times [0, 1]}{(x, 0) \sim (\phi(x), 1)}$$

for some homeomorphism  $\phi$  of  $S$ .

**Remark 2.3.5.** Horizontal surfaces in Seifert fibered spaces and geometrically infinite surfaces in hyperbolic manifolds are all virtual fiber. In particular, if  $g: S \looparrowright M$  is a horizontal surface in a nonelementary Seifert fibered space  $M$  then we may choose  $\phi$  as the identity map of  $S$  (see Lemma 2.1 [RW98]). By Subgroup Tameness Theorem (a combination of Tameness Theorem [Ago], [CG06] and Canary's Covering Theorem [Can96]), if  $g: S \looparrowright M$  is geometrically infinite surface in a hyperbolic manifold  $M$  then we may choose  $\phi$  as a pseudo-Anosov homeomorphism of  $S$  stabilizing each component of  $\partial S$ , fixing periodic points on  $\partial S$ . In addition, the finite cover map  $M_S \rightarrow M$  takes  $S \times \{0\}$  to the image  $g(S)$ , and  $g$  lifts to an embedding  $g': S \hookrightarrow M_S$  (up to homotopy) where  $g'(S)$  is the surface fiber  $S \times \{0\}$  in  $M_S$ .

**Definition 2.3.6.** A properly immersed surface  $g: (B, \partial B) \looparrowright (M, \partial M)$  is called *essential* if it is not homotopic (relative to  $\partial B$ ) to a map  $B \rightarrow \partial M$  and the induced homomorphism  $g_*: \pi_1(B) \rightarrow \pi_1(M)$  is injective. A loop in the surface  $S$  is an *essential curve* if it is neither nullhomotopic or homotopic into the boundary of  $S$ .

**Remark 2.3.7.** The distortion of a horizontal surface subgroup in a Seifert fibered space group is linear (see Chapter 1) and the distortion of a geometrically infinite surface subgroup in a hyperbolic manifold group is exponential (by Subgroup Tameness Theorem).

**Definition 2.3.8** (Clean Surface). Let  $N$  be a non-geometric 3-manifold, and  $\mathcal{T}$  the union of JSJ tori. Let  $S$  be a compact, orientable, connected surface. Let  $g: S \looparrowright N$  be an immersion such that  $S$  and  $\mathcal{T}$  intersects transversely. The immersion is called *clean surface* in  $N$  if the following holds.

1.  $g(\partial S) \subset \mathcal{T} \cup \partial N$
2.  $g(S - \partial S) \cap \partial N = \emptyset$
3.  $S$  intersects the JSJ tori of  $N$  in a minimal finite collection  $\mathcal{T}_g$  of disjoint essential curves of  $S$ .
4. The complementary components of the union of curves in  $\mathcal{T}_g$  are essential subsurfaces (in the sense of Definition 2.3.6) of  $S$ , called *pieces* of  $S$ . Each piece of  $S$  is mapped into either a hyperbolic block or Seifert fibered block of  $N$ . Each piece of  $S$  in a hyperbolic block is either geometrically finite or geometrically infinite. Each piece of  $S$  in a Seifert fibered block is either horizontal or vertical.
5. Let  $N' \rightarrow N$  be the covering space corresponding to the subgroup  $\pi_1(S)$  of  $\pi_1(N)$ . The immersion  $g$  lifts to an embedding  $S \rightarrow N'$ .

**Definition 2.3.9.** The *almost fiber part*  $\Phi(S)$  of  $S$  is the union of all the horizontal or geometrically infinite pieces mapped into Seifert fibered or hyperbolic blocks of  $N$  respectively. The surface  $S$  is called *almost fiber* if  $\Phi(S) = S$ .

**Remark 2.3.10.**

1. Any properly immersed  $\pi_1$ -injective surface  $g: S \looparrowright N$  with  $S$  compact, orientable, connected and not homeomorphic to  $S^2$  is homotopic to a clean surface.
2. Each component of the almost fiber part of a clean surface is a clean almost fiber surface.

Rubinstein-Wang [RW98] introduces a combinatorial invariant to characterize the virtual embedding of a horizontal surface  $S$  in graph manifold  $N$  (i.e, after applying a homotopy, the immersion lifts to an embedding of  $S$  in some finite cover of  $N$ ). In [Liu17], Liu generalizes the invariant of Rubinstein-Wang, which he calls *spirality* (this concept has also been called “dilation” in Chapter 1), to surfaces in closed 3–manifold  $N$ , and proves that spirality is the obstruction to the surface being virtually embedded. Recently, Sun [Sun] generalizes Liu’s work to separability of arbitrary finitely generated subgroup in non-geometric 3–manifolds.

There are two equivalent definitions of spirality given by [Liu17]. Liu first defines spirality by partial dilations and a principal  $\mathbb{Q}^\times$ –bundle over  $\Phi(S)$ . Liu then gives a combinatorial formula (Formula 4.5 in Section 4.2 [Liu17]) and shows that spirality can be computed by this formula. The definition of spirality below is from Section 4.2 in [Liu17] that also can be seen in Section 3.3 [Sun].

**Definition 2.3.11** (Spirality). Let  $g: S \looparrowright N$  be a clean surface in a non-geometric 3–manifold  $N$ . With respect to  $\mathcal{T}_g$ , let  $\Gamma(\Phi(\mathcal{T}_g))$  be the dual graph of  $\Phi(S)$ . For each vertex  $v$  of  $\Gamma(\Phi(\mathcal{T}_g))$ , let  $B_v$  be the piece of  $S$  corresponding to the vertex  $v$ , and let  $M_v$  be the block of  $N$  such that  $B_v$  is mapped into  $M_v$ . We choose a mapping torus

$$M_{B_v} = \frac{B_v \times [0, 1]}{(x, 0) \sim (\phi_v(x), 1)}$$

as in Remark 2.3.5. For each directed edge  $e$  in  $\Gamma(\Phi(\mathcal{T}_g))$  with  $v$  as its initial vertex. Let  $c_e$  be the circle boundary of  $B_v$  corresponding to  $e$ . Let  $T_e$  be the boundary torus of  $M_v$  containing  $c_e$ . Let  $T'_e$  be the boundary torus of  $M_{B_v}$  containing  $c_e$ . We associate to  $c_e$  a nonzero integer  $h_e = [T'_e : T_e]$  where  $[- : -]$  denotes the covering degree. Let  $-e$  denote  $e$  with the orientation reversed. Let

$$\xi_e = h_e / h_{-e}$$

There is a natural homomorphism  $w: H_1(\Phi(S); \mathbb{Z}) \rightarrow \mathbb{Q}^\times$  defined as follows. For any directed 1–cycle  $\gamma$  in  $\Phi(S)$  dual to a cycle of directed edges  $e_1, \dots, e_n$  in  $\Gamma(\Phi(\mathcal{T}_g))$ , the *spirality* of  $\gamma$

is the number

$$w(\gamma) = \prod_{i=1}^n \xi_{e_i}$$

We say the *spirality of  $S$  is trivial* if  $w$  is a trivial homomorphism. The *governor* of  $g$  with respect to the chosen mapping torus  $M_{B_v}$  is the maximum of values  $\xi_e$  with  $e$  varying over all directed edges in the graph  $\Gamma(\Phi(\mathcal{T}_g))$ .

- Remark 2.3.12.** 1. It is shown by Yi Liu in [Liu17] that the homomorphism  $w$  does not depend on the choice of mapping torus  $M_{B_v}$ . Moreover, Yi Liu shows that if  $N$  is a closed manifold, and  $S$  is a closed surface then  $\pi_1(S)$  is separable in  $\pi_1(N)$  if and only if the spirality of  $S$  is trivial (see Theorem 1.1 [Liu17]). Recent work of Sun (see Theorem 1.3 in [Sun]) allows us to say that fundamental group of a clean surface  $S$  in a non-geometric 3-manifold  $N$  is separable if and only if the spirality of  $S$  is trivial.
2. When  $N$  is a graph manifold and  $S$  is horizontal, properly immersed then the notion of spirality in Definition 2.3.11 was previously studied by Rubinstein-Wang [RW98].

The proof of the following proposition is essentially the same as Proposition 4.15 in Chapter 1.

**Proposition 2.3.13.** *For each  $\gamma \subset \Phi(S)$  as in Definition 1.4.10, we define*

$$\Lambda_\gamma = \max \left\{ \prod_{i=j}^k \xi_{e_i} \mid 1 \leq j \leq k \leq n \right\}$$

*If the spirality of  $S$  is trivial, then there exists a positive constant  $\Lambda$  such that  $\Lambda_\gamma \leq \Lambda$  for all all directed 1-cycle  $\gamma$  in  $\Phi(S)$ .*

**Definition 2.3.14.** Let  $F$  be a compact, orientable connected surface with non-empty boundary and  $\chi(F) < 0$ . Let  $\varphi: F \rightarrow F$  be a orientation preserving homeomorphism fixing  $\partial F$  setwise. Let  $M_F = F \times [0, 1] / (x, 0) \sim (\varphi(x), 1)$ . Projection of  $F \times [0, 1]$  onto the second factor induces a map  $\sigma: M_F \rightarrow S^1$  which is a fibration with fiber  $F$ . The foliation

of  $F \times [0, 1]$  by intervals has image in  $M_F$  a one-dimensional foliation which we denote by  $\mathcal{L}$  called the *suspension flow* on  $M_F$ .

In the following, when we say  $\varphi$  *fixes periodic points* on  $\partial F$ , we mean all the periodic points of  $\varphi$  on  $\partial F$  are fixed points of  $\varphi$ . We note that if  $\varphi$  is a pseudo-Anosov, then after passing to a power  $\varphi^m$  of  $\varphi$  for some sufficiently large integer  $m$ , the map  $\varphi^m$  fixes all periodic points of  $\varphi$  on  $\partial F$ .

**Definition 2.3.15** (Degeneracy slope). If the map  $\varphi$  in Definition 2.3.14 fixes periodic points on  $\partial F$  then on each boundary component of  $M_F$ , there exists a closed leaf (of the suspension flow), and different closed leaves in the same boundary component are parallel to each other. We will call any such leaf a *degeneracy slope*. Each boundary component  $c$  of  $F$  is mapped into a boundary torus of  $M_F$ , we fix a degeneracy slope on this torus, and denoted it by  $\mathbf{s}_{cF}$ .

Let  $f: F \times \mathbb{R} \rightarrow F \times \mathbb{R}$  be the homeomorphism given by  $f(x, t) = (\varphi(x), t + 1)$ . We denote  $\langle f \rangle$  be the infinite cyclic group generated by  $f$  and  $\hat{M}_F = F \times \mathbb{R}$ . We note that the quotient space  $F \times \mathbb{R} / \langle f \rangle$  is the mapping torus  $M_F$ . Let the triple  $(\hat{M}_F, \theta^1, \theta^2)$  be the pullback bundle of the fibration  $\sigma: M_F \rightarrow S^1$  by the infinite cyclic covering map  $\mathbb{R} \rightarrow S^1$  where  $\theta^2: F \times \mathbb{R} \rightarrow \mathbb{R}$  is the projection on the second factor and  $\theta^1$  is the quotient map  $F \times \mathbb{R} \rightarrow F \times \mathbb{R} / \langle f \rangle$ . The universal cover  $\tilde{M}_F$  is identified with  $\tilde{F} \times \mathbb{R}$ . For each integer  $n$ , the subspace  $\tilde{F} \times \{n\}$  of  $\tilde{M}_F = \tilde{F} \times \mathbb{R}$  is called a *slice* of  $\tilde{M}$ . We have the following lemma.

**Lemma 2.3.16.** *Let  $M_F$  be the mapping torus of a orientation preserving homeomorphism  $\varphi$  of a compact orientable connected surface  $F$  with nonempty boundary and  $\chi(F) < 0$ . We assume that  $\varphi$  fixes  $\partial F$  setwise and  $\varphi$  fixes periodic points on  $\partial F$ . Equip  $M_F$  with a length metric, and let  $d$  be the metric on  $\tilde{M}_F$  induced from the metric on  $M_F$ . There are positive constants  $L$  and  $C$  such that for any  $x$  in the slice  $\tilde{F} \times \{n\}$  and  $y$  in the slice  $\tilde{F} \times \{m\}$  then*

$$|m - n| \leq L d(x, y) + C$$

*Proof.* Let  $x_0$  be a point on a boundary circle of  $\partial F$  and  $\tilde{x}_0$  be a lift of  $x_0$  in  $\tilde{M}_F$ . We fix generating sets  $\mathcal{A}$  and  $\mathcal{B}$  of  $\pi_1(F, x_0)$  and  $\pi_1(M_F, x_0)$  respectively. We remark that there is a positive constant  $\epsilon > 0$  such that for any integer  $k$  and for any  $z$  in the slice  $\tilde{F} \times \{k\}$  of  $\tilde{M}_F$ , there exists  $z'$  in the slice  $\tilde{F} \times \{k\}$  such that  $z'$  is a lift of the base point  $x_0$  and  $d(z, z') \leq \epsilon$ . Choose  $x'$  in the slice  $\tilde{F} \times \{n\}$  and  $y'$  in the slice  $\tilde{F} \times \{m\}$  so that  $x'$  and  $y'$  are lifts of  $x_0$  with  $d(x, x') \leq \epsilon$  and  $d(y, y') \leq \epsilon$ .

Let  $\sigma: M_F \rightarrow S^1$  be the projection of the bundle  $M_F$ . It follows that we have the short exact sequence:

$$1 \rightarrow \pi_1(F, x_0) \rightarrow \pi_1(M_F, x_0) \rightarrow \mathbb{Z} \rightarrow 1$$

Since  $\sigma_*$  is a homomorphism, it is easy to see that there exists  $L' > 0$  such that

$$|\sigma_*(g) - \sigma_*(g')| \leq L' |g - g'|_{\mathcal{B}}$$

for all  $g, g' \in \pi_1(M_F, x_0)$ .

Since  $\pi_1(M_F, x_0)$  acts geometrically on  $\tilde{M}_F$ , it follows that there exist constants  $A \geq 1$  and  $B \geq 0$  such that

$$|g - g'|_{\mathcal{B}} \leq A d(g(\tilde{x}_0), g'(\tilde{x}_0)) + B$$

for all  $g, g' \in \pi_1(M_F, x_0)$ . It follows that  $|m - n| \leq L' A d(x', y') + L' B$  since  $x'$  and  $y'$  are lifts of  $x_0$ . Since  $d(x', y') \leq d(x, y) + 2\epsilon$ , it follows that

$$|m - n| \leq L d(x, y) + C$$

where  $L = L' A$  and  $C = L' B + 2L' A\epsilon$ . □

The following lemma can be seen in the proof of Theorem 11.9 in [FLP12].

**Lemma 2.3.17.** *Let  $B$  be a surface with nonempty boundary with  $\chi(B) < 0$ . Let  $\varphi: B \rightarrow B$  be a pseudo-Anosov homeomorphism fixing the boundary  $\partial B$  setwise. Let  $\alpha$  be a geodesic such*

that  $\alpha(0)$  and  $\alpha(1)$  belong to a boundary circle of  $B$  and  $\alpha$  is not homotoped to a boundary circle. For any  $n \in \mathbb{N}$ , let  $\gamma_n$  be the geodesic connecting the two endpoints of a lift of  $\varphi^n(\alpha)$  in the universal cover  $\tilde{B}$ , and let  $\beta_n$  be the shortest path in  $\tilde{B}$  joining two boundary lines containing the endpoints of  $\gamma_n$ . Then

1.  $\limsup_{n \rightarrow \infty} \ln(|\gamma_n|_{\tilde{B}})/n = \lambda > 1$
2.  $\limsup_{n \rightarrow \infty} \ln d(\beta_n(0), \gamma_n(0))/n = 0$  and  $\limsup_{n \rightarrow \infty} \ln d(\beta_n(1), \gamma_n(1))/n = 0$ .

### 2.3.1 Metrics on non-geometric 3-manifolds

Since we compute the distortion of a surface subgroup in non-geometric 3-manifold group by using geometry of their universal covers (see Corollary 1.2.10), we need to discuss the metrics on non-geometric 3-manifolds that we are going to use. We note that the choice of length metrics does not affect the distortion, so we will choose a convenient metric.

**Metrics on mixed 3-manifolds:** In the rest of this paper, if we are working on the setting of mixed manifolds, the following metric is the metric we will talk about. If  $N$  is a mixed manifold, it is shown by Leeb [Lee95] that  $N$  admits a smooth Riemannian metric  $d$  of nonpositive sectional curvature with totally geodesic boundary such that  $\mathcal{T}$  is totally geodesic and the sectional curvature is strictly negative on each hyperbolic component of  $N - \mathcal{T}$ .

**Metrics on simple graph manifolds:** A *simple graph manifold*  $N$  is a graph manifold with the following properties: Each Seifert component is a trivial circle bundle over an orientable surface of genus at least 2. The intersection numbers of fibers of adjacent Seifert components have absolute value 1. It was shown by Kapovich and Leeb that any graph manifold  $N$  has a finite cover  $\hat{N}$  that is a simple graph manifold [KL98].

In the rest of this paper, if we are working on the setting of simple graph manifolds, the following metric (described by Kapovich–Leeb [KL98]) will be the metric we will talk about. If  $N$  is a simple graph manifold, on each Seifert fibered block  $M_i = F_i \times S^1$  we choose a

hyperbolic metric on  $F_i$  and then equip  $M_i$  with the product metric  $d_i$ . There is a length metric  $d$  on  $N$  with the following properties. There is  $K > 0$  such that for each Seifert fibered block  $M_i$ , we have

$$\frac{1}{K}d_i(x, y) \leq d(x, y) \leq Kd_i(x, y)$$

for all  $x$  and  $y$  in  $M_i$ .

**Remark 2.3.18.** There exists a positive lower bound  $\rho$  for the distance between any two distinct JSJ planes in  $\tilde{N}$ .

## 2.4 Distortion of surfaces is determined by the almost fiber part

The goal in this section is to show that the distortion of the fundamental group of a surface  $S$  in the fundamental group of a non-geometric 3-manifold  $N$  can be determined by looking at the distortion of the almost fiber part  $\Phi(S)$ .

**Theorem 2.4.1.** *Let  $g: S \looparrowright N$  be a clean surface in a non-geometric 3-manifold  $N$ . For each component  $S_i$  of  $\Phi(S)$ , let  $\delta_{S_i}$  be the distortion of  $\pi_1(S_i)$  in  $\pi_1(N)$ . Then the distortion of  $H = \pi_1(S)$  in  $G = \pi_1(N)$  satisfies*

$$f \preceq \Delta_H^G \preceq \bar{f}$$

where

$$f(n) := \max\{ \delta_{S_i}(n) \mid S_i \text{ is a component of } \Phi(S) \}$$

and  $\bar{f}$  is the superadditive closure of  $f$ .

**Remark 2.4.2.** The definition of  $f$  depends on choices of generating sets for  $\pi_1(N)$  and each  $\pi_1(S_i)$ . In general it is unknown whether  $f \sim \bar{f}$  for an arbitrary distortion function  $f$ . But

in Section 2.5 we will see this is true because each function  $\delta_{S_i}$  is either linear, quadratic, exponential or double exponential.

We use the convention that  $f(n) = 0$  if  $\Phi(S) = \emptyset$ . Note that the zero function is equivalent to a linear function by Definition 1.2.7. Therefore we obtain the following corollary.

**Corollary 2.4.3.** *Let  $g: S \looparrowright N$  be a clean surface in a non-geometric 3-manifold  $N$ . If the almost fiber part  $\Phi(S)$  is empty then the distortion of  $\pi_1(S)$  in  $\pi_1(N)$  is linear.*

Regarding Theorem 2.4.1, the proof  $f \preceq \Delta_H^G$  is not hard to see, meanwhile the proof  $\Delta_H^G \preceq \bar{f}$  requires more work. We sketch here the idea of the proof of the upper bound case. We fix a lifted point  $\tilde{s}_0$  in  $\tilde{S}$ , and let  $h \in \pi_1(S, s_0)$  such that the distance of  $\tilde{s}_0$  and  $h(\tilde{s}_0)$  in  $\tilde{N}$  is less than  $n$ . We will construct a path  $\gamma'$  in  $\tilde{N}$  connecting  $\tilde{s}_0$  to  $h(\tilde{s}_0)$  such that  $|\gamma'|$  is bounded above by a linear function in term of  $n$ . We then construct a path  $\beta$  in  $\tilde{S}$  connecting  $\tilde{s}_0$  to  $h(\tilde{s}_0)$  such that  $\beta$  stays close to  $\gamma'$  every time they travel in the same block containing a piece which is either vertical or geometrically finite (see Lemma 2.4.4 and Lemma 2.4.7).

**Lemma 2.4.4.** *Let  $F$  be a connected compact hyperbolic surface with non-empty boundary. Let  $M = F \times S^1$ . Let  $g: (S, s_0) \looparrowright (M, x_0)$  be an essential, vertical surface. We equip  $M$  with a length metric and lift this metric to the metric  $d$  in the universal covers  $\tilde{M}$ . Then there exists a constant  $R$  such that the following holds. Let  $P$  and  $P'$  be two distinct boundary planes in  $\tilde{M}$  such that  $P \cap \tilde{S} \neq \emptyset$  and  $P' \cap \tilde{S} \neq \emptyset$ . Let  $x$  and  $y$  be points in  $P$  and  $P'$ , and  $\alpha$  be a geodesic in  $(\tilde{M}, d)$  connecting  $x$  to  $y$ . Then there exists a path  $\beta$  in  $\tilde{S}$  connecting a point in  $P \cap \tilde{S}$  to a point in  $P' \cap \tilde{S}$  such that  $\beta(0), \beta(1) \in \mathcal{N}_R(\alpha)$ .*

*Proof.* Since  $S$  is orientable and vertical, it follows that  $S$  is an annulus. The map  $g$  is a vertical map and thus the image  $g(S)$  in  $M$  is  $\gamma \times S^1$  where  $\gamma$  is a proper arc in the base surface  $F$  of  $M$  (i.e,  $\gamma$  could not be homotoped to a path in a boundary circle). We fix a hyperbolic metric  $d_F$  on  $F$  such that the boundary is totally geodesic. We lift the metric  $d_F$  to the metric  $d_{\tilde{F}}$  in the universal cover  $\tilde{F}$  of  $F$ . We equip  $\tilde{M} = \tilde{F} \times \mathbb{R}$  with the product

metric  $d'$ . We note that the identity map  $(\tilde{M}, d) \rightarrow (\tilde{M}, d')$  is a  $(K, C)$ -quasi-isometric for some constant  $K$  and  $C$ . In  $\tilde{M}$ , we note that  $\tilde{S}$  is  $\tilde{\gamma} \times \mathbb{R}$  where  $\tilde{\gamma}$  is a path lift of  $\gamma$  in  $\tilde{F}$ .

We note that  $(\tilde{F}, d_{\tilde{F}})$  is bilipschitz homeomorphic to a fattened tree (see the paragraph after Lemma 1.1 [BN08]). Thus, there exists  $A_0 > 0$  such that the following holds. Let  $\ell$  and  $\ell'$  be two distinct boundary lines in  $\tilde{F}$ . Let  $[p, p']$  be a geodesic of shortest length from  $\ell$  to  $\ell'$ . If  $\tau$  is a path in  $\tilde{F}$  connecting a point in  $\ell$  to a point in  $\ell'$  then  $[p, p'] \subset \mathcal{N}'_{A_0}(\tau)$  where  $\mathcal{N}'_{A_0}(\tau)$  is the  $A_0$ -neighborhood of  $\tau$  with respect to  $d_{\tilde{F}}$ -metric.

Let  $|\tilde{\gamma}|_{\tilde{F}}$  be the length of  $\tilde{\gamma}$  with respect to  $d_{\tilde{F}}$ -metric. Let  $L = 2|\tilde{\gamma}|_{\tilde{F}} + 2A_0$ . Let  $\alpha_{\tilde{F}}$  be the projection of  $\alpha$  on the first factor  $\tilde{F}$  of  $\tilde{M}$ . We first show that  $\tilde{\gamma} \subset \mathcal{N}'_L(\alpha_{\tilde{F}})$ . Indeed, let  $\ell_1$  and  $\ell_2$  be the boundary lines in  $\tilde{F}$  such that  $\tilde{\gamma}(0) \in \ell_1$  and  $\tilde{\gamma}(1) \in \ell_2$ . Let  $[p_1, p_2]$  be a geodesic of shortest length from  $\ell_1$  to  $\ell_2$ . According to the previous paragraph, we have  $[p_1, p_2] \subset \mathcal{N}'_{A_0}(\alpha_{\tilde{F}})$  and  $[p_1, p_2] \subset \mathcal{N}'_{A_0}(\tilde{\gamma})$ . Since  $p_1 \in \mathcal{N}'_{A_0}(\tilde{\gamma})$ , it follows that there exists  $a \in \tilde{\gamma}$  such that  $d_{\tilde{F}}(p_1, a) \leq A_0$ . Thus  $d_{\tilde{F}}(\tilde{\gamma}(0), p_1) \leq d_{\tilde{F}}(\tilde{\gamma}(0), a) + d_{\tilde{F}}(a, p_1) \leq |\tilde{\gamma}|_{\tilde{F}} + d_{\tilde{F}}(a, p_1) \leq |\tilde{\gamma}|_{\tilde{F}} + A_0$ . For any  $x \in \tilde{\gamma}$ , we have  $d_{\tilde{F}}(x, p_1) \leq d_{\tilde{F}}(x, \tilde{\gamma}(0)) + d_{\tilde{F}}(\tilde{\gamma}(0), p_1) \leq |\tilde{\gamma}|_{\tilde{F}} + d_{\tilde{F}}(\tilde{\gamma}(0), p_1) \leq |\tilde{\gamma}|_{\tilde{F}} + |\tilde{\gamma}|_{\tilde{F}} + A_0 = 2|\tilde{\gamma}|_{\tilde{F}} + A_0$ . It follows that  $\tilde{\gamma} \subset \mathcal{N}'_{2|\tilde{\gamma}|_{\tilde{F}}+A_0}([p_1, p_2])$ . Using  $\tilde{\gamma} \subset \mathcal{N}'_{2|\tilde{\gamma}|_{\tilde{F}}+A_0}([p_1, p_2])$  and  $[p_1, p_2] \subset \mathcal{N}'_{A_0}(\alpha_{\tilde{F}})$  we have  $\tilde{\gamma} \subset \mathcal{N}'_{2|\tilde{\gamma}|_{\tilde{F}}+2A_0}(\alpha_{\tilde{F}}) = \mathcal{N}'_L(\alpha_{\tilde{F}})$ .

Since  $\tilde{\gamma} \subset \mathcal{N}'_L(\alpha_{\tilde{F}})$ , there exist  $u_0 \in \alpha_{\tilde{F}}$  and  $u_1 \in \alpha_{\tilde{F}}$  such that  $d_{\tilde{F}}(\tilde{\gamma}(0), u_0) \leq L$  and  $d_{\tilde{F}}(\tilde{\gamma}(1), u_1) \leq L$ . Choose  $s_0, s_1 \in \mathbb{R}$  such that  $(u_0, s_0), (u_1, s_1) \in \alpha$ . It follows that  $d((\tilde{\gamma}(0), s_0), (u_0, s_0)) \leq Kd'((\tilde{\gamma}(0), s_0), (u_0, s_0)) + C = Kd_{\tilde{F}}(\tilde{\gamma}(0), u_0) + C \leq KL + C$ . Hence  $(\tilde{\gamma}(0), s_0) \in \mathcal{N}_{KL+C}(\alpha)$ . Similarly, we have  $(\tilde{\gamma}(1), s_1) \in \mathcal{N}_{KL+C}(\alpha)$ . Note that  $(\tilde{\gamma}(0), s_0)$  and  $(\tilde{\gamma}(1), s_1)$  are in  $\tilde{S} = \tilde{\gamma} \times \mathbb{R}$ . Let  $\beta$  be a path in  $\tilde{S}$  connecting  $(\tilde{\gamma}(0), s_0)$  to  $(\tilde{\gamma}(1), s_1)$ . The end points of  $\beta$  are in  $\mathcal{N}_R(\alpha)$ .  $\square$

**Lemma 2.4.5.** *Let  $g: (S, s_0) \looparrowright (M, x_0)$  be a essential, geometrically finite surface in a hyperbolic manifold  $M$  with nonempty toroidal boundary such that  $\partial S \neq \emptyset$ . Let  $\tilde{g}: (\tilde{S}, \tilde{s}_0) \hookrightarrow (\tilde{M}, \tilde{x}_0)$  be a lift of  $g$ . Then for any distinct boundary lines  $\ell$  and  $\ell'$  of  $\partial \tilde{S}$ , the images  $\tilde{g}(\ell)$  and  $\tilde{g}(\ell')$  lie in different boundary planes of  $\partial \tilde{M}$ .*

*Proof.* Suppose by the way of contradiction that  $\tilde{g}(\ell)$  and  $\tilde{g}(\ell')$  are lines in the same boundary

plane  $\tilde{T}$ . Since  $g: (S, s_0) \looparrowright (M, x_0)$  is essential,  $S$  could not be annulus or a disk. Thus,  $S$  is a hyperbolic surface. Let  $d_S$  be a hyperbolic metric on  $S$  such that the boundary is totally geodesic and let  $d_M$  be a non-positively curved metric on the manifold with boundary  $M$ . We lift these metrics to metrics  $d_{\tilde{S}}$  and  $d_{\tilde{M}}$  in the universal covers  $\tilde{S}$  and  $\tilde{M}$  respectively. Since  $g: (S, s_0) \looparrowright (M, x_0)$  is geometrically finite, it follows that  $\tilde{g}: (\tilde{S}, d_{\tilde{S}}) \hookrightarrow (\tilde{M}, d_{\tilde{M}})$  is an  $(L, C)$ -quasi-isometric embedding for some constant  $L$  and  $C$ .

Since  $\tilde{g}$  is an embedding, it follows that  $\tilde{g}(\ell)$  and  $\tilde{g}(\ell')$  are disjoint lines in  $\tilde{T}$ . We note that, on the one hand the Hausdorff distance of two sets  $\ell$  and  $\ell'$  with respect to  $d_{\tilde{S}}$ -metric is infinite (this follows from Lemma 3.2 in Chapter 1). On the other hand, the Hausdorff distance of two sets  $\tilde{g}(\ell)$  and  $\tilde{g}(\ell')$  with respect to  $d_{\tilde{M}}$ -metric is finite. (this follows from the fact that  $A = \text{stab}(\tilde{T})$  in  $\pi_1(M)$  acts isometrically on  $\tilde{T}$  and  $\text{stab}(\tilde{g}(\ell))$  and  $\text{stab}(\tilde{g}(\ell'))$  are commensurable in  $A$ ). This could not happen since  $\tilde{g}$  is a quasi-isometric embedding.  $\square$

**Remark 2.4.6.** Lemma 2.4.5 can be proven by using malnormality of the peripheral subgroups of  $\pi_1(S)$ .

**Lemma 2.4.7.** *Let  $M$  be a hyperbolic manifold with nonempty toroidal boundary. Let  $g: (S, s_0) \looparrowright (M, x_0)$  be a essential, geometrically finite surface such that  $\partial S \neq \emptyset$ . Equip  $M$  with a non-positively curved metric and lift this metric to the universal cover  $\tilde{M}$  denoted by  $d$ . Then there exists a constant  $R$  such that the following holds. Let  $P$  and  $P'$  be two distinct boundary planes in  $\tilde{M}$  such that  $P \cap \tilde{S} \neq \emptyset$  and  $P' \cap \tilde{S} \neq \emptyset$ . Let  $x$  and  $y$  be points in  $P$  and  $P'$  respectively, and  $\alpha$  be a geodesic in  $\tilde{M}$  connecting  $x$  to  $y$ . Then there is a path  $\beta$  in  $\tilde{S}$  connecting a point in  $P \cap \tilde{S}$  to a point in  $P' \cap \tilde{S}$  such that  $\beta(0), \beta(1) \in \mathcal{N}_R(\alpha)$ .*

*Proof.* Let  $G = \pi_1(M, x_0)$  and  $H = \pi_1(S, s_0)$ . Let  $\mathbb{P}$  be the collection of fundamental groups of tori boundary of  $M$ . Since  $g: (S, s_0) \looparrowright (M, x_0)$  is geometrically finite, it follows that  $\pi_1(S, s_0)$  is relatively quasiconvex in the relatively hyperbolic group  $(G, \mathbb{P})$  (see Corollary 1.6 in [Hru10]). Since  $d$  is a complete non-positively curved metric, it follows from Cartan-Hadamard Theorem that  $(\tilde{M}, d)$  is a CAT(0) space. It also follows from Corollary 1.6

in [Hru10] that the orbit space  $\pi_1(S, s_0)(\tilde{x}_0)$  is quasiconvex in  $(\tilde{M}, d)$ . It follows that  $\tilde{S}$  is  $\epsilon_0$ -quasiconvex in  $(\tilde{M}, d)$  for some positive constant  $\epsilon_0$ .

Applying Lemma 2.2.3 to the surface subgroup and the fundamental group of each torus boundary, we have the following fact: For any  $r > 0$ , there exists  $r' = r'(r) > 0$  such that whenever  $x \in \mathcal{N}_r(\tilde{T}) \cap \mathcal{N}_r(\tilde{S})$  and  $\tilde{T}$  is an arbitrary boundary plane of  $\tilde{M}$  with nonempty intersection with  $\tilde{S}$ , then  $x \in \mathcal{N}_{r'}(\tilde{T} \cap \tilde{S})$ .

We note that  $(\tilde{M}, d)$  is a CAT(0) space with isolated flats. Let  $\epsilon_1$  be the positive constant given by Proposition 8 [HK09]. Let  $[p, q]$  be a geodesic of shortest length from  $P$  to  $P'$ . Then every geodesic from  $P$  to  $P'$  must come within a distance  $\epsilon_1$  of both  $p$  and  $q$ . Since  $\alpha$  is a geodesic in  $\tilde{M}$  connecting  $x \in P$  to  $y \in P'$ , it follows that  $\{p, q\} \in \mathcal{N}_{\epsilon_1}(\alpha)$ . Moreover, there exist points  $x'$  and  $y'$  in a geodesic  $\gamma$  from  $P \cap \tilde{S}$  to  $P' \cap \tilde{S}$  such that  $d(x', p) \leq \epsilon_1$  and  $d(y', q) \leq \epsilon_1$ . Hence  $x' \in \mathcal{N}_{\epsilon_1}(P)$  and  $y' \in \mathcal{N}_{\epsilon_1}(P')$ . We note that the end points of  $\gamma$  belong to  $\tilde{S}$ . Using quasiconvexity of  $\tilde{S}$ , we have  $x', y' \in \mathcal{N}_{\epsilon_0}(\tilde{S})$ . Thus there exists a constant  $\epsilon_2$  depending on  $\epsilon_0$  and  $\epsilon_1$  such that  $x' \in \mathcal{N}_{\epsilon_2}(P) \cap \mathcal{N}_{\epsilon_2}(\tilde{S})$  and  $y' \in \mathcal{N}_{\epsilon_2}(P') \cap \mathcal{N}_{\epsilon_2}(\tilde{S})$  (we may choose  $\epsilon_2 = \epsilon_0 + \epsilon_1$ ). Let  $r' = r'(\epsilon_2)$  be the constant given in the previous paragraph with respect to  $\epsilon_2$ . It follows that  $x' \in \mathcal{N}_{r'}(P \cap \tilde{S})$  and  $y' \in \mathcal{N}_{r'}(P' \cap \tilde{S})$ . Thus,  $d(x', u) \leq r'$  and  $d(y', v) \leq r'$  for some points:  $u \in P \cap \tilde{S}$  and  $v \in P' \cap \tilde{S}$ . Let  $\beta$  be a path in  $\tilde{S}$  connecting  $u$  to  $v$ . Since  $d(\beta(0), p) = d(u, p) \leq d(u, x') + d(x', p) \leq r' + \epsilon_1$  and  $p \in \mathcal{N}_{\epsilon_1}(\alpha)$ , it follows that  $\beta(0) \in \mathcal{N}_{r'+2\epsilon_1}(\alpha)$ . Similarly, since  $d(\beta(1), q) = d(v, q) \leq d(v, y') + d(y', q) \leq r' + \epsilon_1$  and  $q \in \mathcal{N}_{\epsilon_1}(\alpha)$ , it follows that  $\beta(1) \in \mathcal{N}_{r'+2\epsilon_1}(\alpha)$ . Let  $R = r' + 2\epsilon_1$ , the lemma is confirmed.

□

Let  $g: S \looparrowright N$  be the immersion in the statement of Theorem 2.4.1.

**Definition 2.4.8.** Lift the JSJ decomposition of the manifold  $N$  to the universal cover  $\tilde{N}$ , and let  $\mathbf{T}_N$  be the tree dual to this decomposition of  $\tilde{N}$ . Lift the collection  $\mathcal{T}_g$  to the universal cover  $\tilde{S}$ . The tree dual to this decomposition of  $\tilde{S}$  will be denoted by  $\mathbf{T}_S$ . The map  $\tilde{g}$  induces a map  $\zeta: \mathbf{T}_S \rightarrow \mathbf{T}_N$ .

**Remark 2.4.9.** For each geometrically infinite piece  $\tilde{B}$  in  $\tilde{S}$ , let  $\tilde{M}$  be the block of  $\tilde{N}$  such that  $\tilde{g}(\tilde{B}) \subset \tilde{M}$ . By Remark 2.3.5, the immersion  $B \looparrowright M$  lifts to an embedding (up to homotopy) in a finite cover  $M_B$  of  $M$  which is fibered over circle with a fiber  $B$ . Let  $\mathcal{L}_{M_B}$  be the suspension flow on  $M_B$ . We note that  $\tilde{B}$  meets every flow line of  $\tilde{\mathcal{L}}_{M_B}$  once.

**Proposition 2.4.10.** *The map  $\zeta$  is injective.*

*Proof.* A simplicial map between trees is injective if it is locally injective (see [Sta83]). Suppose by way of contradiction that  $\zeta$  is not locally injective. Then there exists three distinct pieces  $\tilde{B}_1, \tilde{B}_2$  and  $\tilde{B}_3$  in  $\tilde{S}$  such that  $\tilde{B}_1 \cap \tilde{B}_2$  is a line  $\ell_1$  and  $\tilde{B}_2 \cap \tilde{B}_3$  is a line  $\ell_2$  and the images  $\tilde{g}(\tilde{B}_1)$  and  $\tilde{g}(\tilde{B}_3)$  lie in the same block  $\tilde{M}_1$  of  $\tilde{N}$ . Let  $\tilde{M}_2$  be the block containing the image  $\tilde{g}(\tilde{B}_2)$ . We have  $\tilde{g}(\ell_1)$  and  $\tilde{g}(\ell_2)$  are subsets of the JSJ plane  $\tilde{T} = \tilde{M}_1 \cap \tilde{M}_2$ . Since the map  $\tilde{g}$  is an embedding, it follows that  $\tilde{g}(\ell_1)$  and  $\tilde{g}(\ell_2)$  are disjoint lines in the plane  $\tilde{T}$ . If  $\tilde{B}_2$  is horizontal, this contradicts Lemma 6.3 in Chapter 1. If  $\tilde{B}_2$  is geometrically infinite, this contradicts Remark 2.4.9. If  $\tilde{B}_2$  is vertical, this contradicts the fact that  $B_2$  is essential. If  $\tilde{B}_2$  is geometrically finite, this contradicts Lemma 2.4.5.  $\square$

In the rest of this section, we equip  $S$  with a hyperbolic metric  $d_S$  such that the boundary (if nonempty) is totally geodesic.

*Proof of Theorem 2.4.1.* The non-geometric manifold  $N$  has a finite cover such that each Seifert block in this cover is a trivial circle bundle over a hyperbolic surface (see Lemma 3.1 [PW14b]). We elevate  $S \looparrowright N$  into this finite cover. By Proposition 2.2.2, it suffices to prove the theorem in this cover. Thus, without loss of generality, we can assume that each Seifert block in  $N$  is a trivial circle bundle over a hyperbolic surface.

Now we deal with the issue of metrics: We always have a convenient metric (in the sense of Section 3.1) on a mixed manifold. In the graph manifold case, we may pass to a further finite cover and hence assume that it is a simple graph manifold. Then we can choose a convenient metric on it as described in Section 3.1.

We first show that  $f \preceq \Delta_H^G$ . Every finitely generated subgroup of a surface group or free group is undistorted. It follows that for any component  $S_i$  of  $\Phi(S)$  then  $\pi_1(S_i)$  is undistorted in  $\pi_1(S)$ . It follows from Proposition 2.2.1 that  $\delta_{S_i}$  is dominated by the distortion of  $\pi_1(S)$  in  $\pi_1(N)$ . Therefore,  $f \preceq \Delta_H^G$ .

We are now going to prove  $\Delta_H^G \preceq \bar{f}$ , which is less trivial. Let  $h \in H$  such that  $d(\tilde{s}_0, h(\tilde{s}_0)) \leq n$ , we wish to show that  $d_{\tilde{S}}(\tilde{s}_0, h(\tilde{s}_0))$  is bounded above by  $\bar{f}(n)$ . The theorem is proved by an application of Corollary 1.2.10. For each component  $S_i$  of  $\Phi(S)$ , let  $\tilde{\delta}_{S_i}$  be the distortion of  $\tilde{S}_i$  in  $\tilde{N}$ . We note that  $\tilde{\delta}_{S_i} \sim \delta_{S_i}$ . Let

$$\tau(n) := \max\{\tilde{\delta}_{S_i}(n) \mid S_i \text{ is a component of } \Phi(S)\}$$

and  $\bar{\tau}$  is the superadditive closure of  $\tau$ . We note that  $\bar{\tau} \sim \bar{f}$  by Remark 2.2.5.

We will assume that  $\tilde{s}_0$  and  $h(\tilde{s}_0)$  belong to distinct pieces of  $\tilde{S}$ , otherwise the fact  $d_{\tilde{S}}(\tilde{s}_0, h(\tilde{s}_0))$  is bounded above by  $\bar{f}(n)$  is trivial. Without of generality, we assume that  $s_0$  belongs to a curve in the collection  $\mathcal{T}_g$ . Let  $\mathcal{Q}$  be the family of lines in  $\tilde{S}$  that are lifts of curves of  $\mathcal{T}_g$ . We note that there are distinct lines  $\ell$  and  $\ell'$  in  $\mathcal{Q}$  such that  $\tilde{s}_0 \in \ell$  and  $h(\tilde{s}_0) \in \ell'$ . Let  $e$  and  $e'$  be the non-oriented edges in the tree  $\mathbf{T}_S$  corresponding to the lines  $\ell$  and  $\ell'$  respectively. Choose the non backtracking path joining  $e$  to  $e'$  in the tree  $\mathbf{T}_S$ , with ordered vertices  $v_0, v_1, \dots, v_{k-1}$  where  $v_1$  is not a vertex on the edge  $e$  and  $v_{k-2}$  is not a vertex on the edge  $e'$ . We denote the pieces corresponding to the vertices  $v_i$  by  $\tilde{B}_i$  and the blocks corresponding to the vertices  $\zeta(v_i)$  by  $\tilde{M}_i$  with  $i = 0, 1, \dots, k-1$ . We note that the blocks  $\tilde{M}_i$  are distinct because  $\zeta$  is injective by Proposition 2.4.10.

For each piece  $B$  of  $S$ , let  $M$  be the block of  $N$  such that  $B$  is mapped into  $M$ . If  $B \looparrowright M$  is vertical, let  $R_B$  be the constant given by Lemma 2.4.4. If  $B \looparrowright M$  is geometrically finite, we let  $R_B$  be the constant given by Lemma 2.4.7. Since the number of vertical and geometrically finite pieces of  $S$  is finite, we let  $R$  be the maximum of the numbers  $R_B$  chosen above.

By a similar argument as in the proof of Theorem 6.1 in Chapter 1, we can find a path

$\gamma$  connecting  $\tilde{s}_0$  to  $h(\tilde{s}_0)$  that intersects each plane  $\tilde{T}_i = \tilde{M}_{i-1} \cap \tilde{M}_i$  with  $i = 1, 2, \dots, k-1$  exactly at one point  $y_i$  and satisfies  $|\gamma| \leq Kd(\tilde{s}_0, h(\tilde{s}_0))$  where the constant  $K$  depends only on the metric  $d$ . Here  $|\cdot|$  denotes the length of a path with respect to the metric  $d$ .

If a piece  $\tilde{B}_i$  is either vertical or geometrically finite in the corresponding block  $\tilde{M}_i$ , we let  $\alpha_i$  be a path in  $\tilde{M}_i$  connecting  $y_i$  to  $y_{i+1}$  and  $\beta_i$  be a path in  $\tilde{B}_i$  connecting a point in  $\tilde{B}_i \cap \tilde{T}_i$  to a point in  $\tilde{B}_i \cap \tilde{T}_{i+1}$  as given by Lemma 2.4.4 (when  $\tilde{B}_i$  is vertical) and Lemma 2.4.7 (when  $\tilde{B}_i$  is geometrically finite). We replace  $\beta_i$  by a geodesic in  $\tilde{S}$  connecting  $\beta_i(0)$  to  $\beta_i(1)$ . **By abuse of notation, we still denote this geodesic by  $\beta_i$ .**

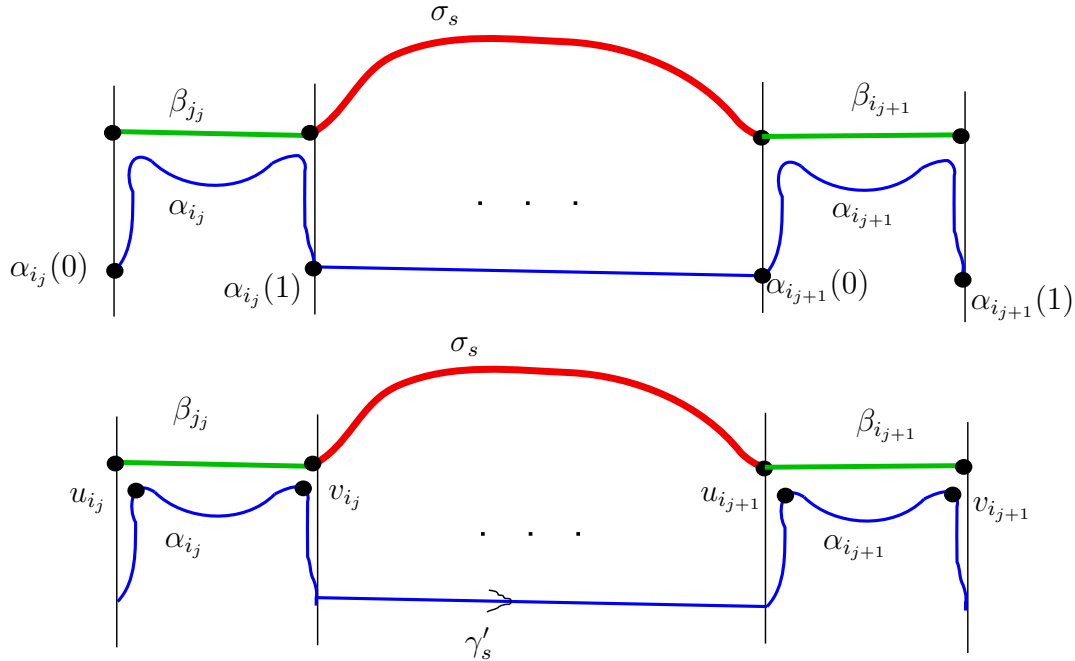

Figure 2.1: The upper picture illustrates the two end points of each path  $\beta_{i_j}$  are within a  $R$ -neighborhood of  $\alpha_{i_j} \subset \gamma'$ . We add a geodesic in the almost fiber part of  $\tilde{S}$  connecting  $\beta_{i_j}(1)$  to  $\beta_{i_{j+1}}(0)$ . The lower picture illustrates the point  $v_{i_j}$  (resp.  $u_{i_j}$ ) is within  $R$ -distance from  $\beta_{i_j}(0)$  (resp.  $\beta_{i_j}(1)$ ). The path  $\gamma'_s$  is the subpath of  $\gamma'$  that connects  $v_{i_j}$  to  $u_{i_{j+1}}$ .

On the path  $\gamma$ , every time the piece  $\tilde{B}_i$  is either vertical or geometrically finite, we replace the subpath  $\gamma|_{[y_i, y_{i+1}]}$  of  $\gamma$  by  $\alpha_i$ . We therefore obtain a new path denoted by  $\gamma'$  such that

$$|\gamma'| \leq KRd(\tilde{s}_0, h(\tilde{s}_0)) \leq KRn$$

We now construct a path  $\beta$  in  $\tilde{S}$  connecting  $\tilde{s}_0$  to  $h(\tilde{s}_0)$  which stays close to  $\gamma'$  every time

they both travel the same a block containing a piece which is either vertical or geometrically finite (see Figure 2.1). Let  $\tilde{B}_{i_0}, \dots, \tilde{B}_{i_t}$  be the collection of the vertical or geometrically finite pieces where  $0 \leq i_0 \leq \dots \leq i_t \leq k-1$ . From the given paths  $\beta_{i_0}, \dots, \beta_{i_t}$ , we obtain a path  $\beta$  in  $\tilde{S}$  connecting  $\tilde{s}_0$  to  $h(\tilde{s}_0)$  by adding a geodesic in  $\tilde{S}$  connecting the endpoint of  $\beta_{i_j}$  to the initial point of  $\beta_{i_{j+1}}$  where  $j$  varies from 0 to  $t-1$ , adding a geodesic in  $\tilde{S}$  connecting  $\tilde{s}_0$  to the initial point of  $\beta_{i_0}$ , and a geodesic in  $\tilde{S}$  connecting the endpoint of  $\beta_{i_t}$  to  $h(\tilde{s}_0)$ .

**Claim 1:** There exists a linear function  $J$  not depending on the choices of  $n$ ,  $h$ , or  $\beta$  such that  $\sum_{j=0}^t |\beta_{i_j}|_{\tilde{S}} \leq J(n)$ .

Since vertical pieces and geometrically finite pieces of  $S$  are undistorted in the corresponding blocks of  $N$ , and there are finite many of vertical pieces and geometrically finite pieces, we have a constant  $\epsilon > 0$  such that the following holds. Suppose that  $B$  is either vertical piece or geometrically finite piece, then for any  $x, y \in \tilde{B}$  we have  $d_{\tilde{S}}(x, y) \leq \epsilon d(x, y) + \epsilon$ .

We recall that  $\alpha_{i_j}$  is a subpath of  $\gamma'$  and  $\beta_{i_j}$  is a geodesic in  $\tilde{S}$ . Since  $\beta_{i_j}(0), \beta_{i_j}(1) \in \mathcal{N}_R(\alpha_{i_j})$ , we have  $d(\beta_{i_j}(0), \beta_{i_j}(1)) \leq 2R + |\alpha_{i_j}|$ . Let  $\rho$  be the constant given by Remark 2.3.18. We note that  $k \leq n/\rho$ .

We have

$$\begin{aligned}
\sum_{j=0}^t |\beta_{i_j}|_{\tilde{S}} &= \sum_{j=0}^t d_{\tilde{S}}(\beta_{i_j}(0), \beta_{i_j}(1)) \leq \sum_{j=0}^t (\epsilon d(\beta_{i_j}(0), \beta_{i_j}(1)) + \epsilon) \\
&\leq \sum_{j=0}^t (\epsilon(2R + |\alpha_{i_j}|) + \epsilon) = \sum_{j=0}^t \epsilon |\alpha_{i_j}| + \sum_{j=0}^t (2R\epsilon + \epsilon) \\
&\leq \epsilon \sum_{j=0}^t |\alpha_{i_j}| + (t+1)(2R\epsilon + \epsilon) \leq \epsilon |\gamma'| + (t+1)(2R\epsilon + \epsilon) \\
&\leq \epsilon |\gamma'| + (k+1)(2R\epsilon + \epsilon) \leq \epsilon |\gamma'| + (n/\rho + 1)(2R\epsilon + \epsilon) \\
&\leq \epsilon K R n + (n/\rho + 1)(2R\epsilon + \epsilon)
\end{aligned}$$

Let  $J(n) = \epsilon K R n + (n/\rho + 1)(2R\epsilon + \epsilon)$ , the claim is confirmed.

We consider the complement of  $\beta - \cup_{j=0}^t \beta_{i_j}$ , which can be written as a disjoint union of

subpaths  $\sigma_1, \dots, \sigma_m$  of  $\beta$  with  $m \leq k$ .

**Claim 2:** For each  $i = 1, \dots, m$ , there exists a subpath  $\gamma'_i$  of  $\gamma'$  such that

$$d(\sigma_i(0), \sigma_i(1)) \leq 2R + |\gamma'_i|$$

and  $\sum_{i=1}^m |\gamma'_i| \leq 3|\gamma'|$ .

Indeed, let  $p(i) \neq q(i)$  be two numbers in the collection  $\{i_0, \dots, i_t\}$  such that  $\sigma_i(0)$  is the endpoint of  $\beta_{p(i)}$  and  $\sigma_i(1)$  is the initial point of  $\beta_{q(i)}$ . For convenience, let's relabel  $p = p(i)$ ,  $q = q(i)$ . Note that it is possible that the pieces  $\tilde{B}_p$  and  $\tilde{B}_q$  are adjacent. Since  $\beta_p \subset \mathcal{N}_R(\alpha_p)$  and  $\beta_q \subset \mathcal{N}_R(\alpha_q)$ , it follows that  $d(\beta_p(1), v_p) \leq R$  and  $d(\beta_q(0), u_q) \leq R$  for some  $v_p \in \alpha_p$ ,  $u_q \in \alpha_q$ .

Let  $\gamma'_i$  be the concatenation  $\alpha_{p[v_p, \alpha_p(1)]} \cdot \gamma'_{[[\alpha_p(1), \alpha_q(0)]}$  (see Figure 2.1). It follows that  $d(v_p, u_q) \leq |\gamma'_i|$ . Using  $d(\beta_p(1), v_p) \leq R$ ,  $d(\beta_q(0), u_q) \leq R$ ,  $d(v_p, u_q) \leq |\gamma'_i|$ , and the triangle inequality, we have

$$\begin{aligned} d(\sigma_i(0), \sigma_i(1)) &= d(\beta_p(1), \beta_q(0)) \leq d(\beta_p(1), v_p) + d(v_p, u_q) + d(u_q, \beta_q(0)) \\ &\leq R + d(v_p, u_q) + R = 2R + d(v_p, u_q) \leq 2R + |\gamma'_i| \end{aligned}$$

Recall that  $\alpha_{i_j}$  is a subpath of  $\gamma'$  with  $i_j \in \{i_0, \dots, i_t\}$  and  $\sum_{j=0}^t |\alpha_{i_j}| \leq |\gamma'|$ . By the construction of  $\gamma'_i$ , we have

$$|\gamma'_i| \leq |\alpha_p| + |\alpha_q| + \left| \gamma'_{[[\alpha_p(1), \alpha_q(0)]} \right| = |\alpha_{p(i)}| + |\alpha_{q(i)}| + \left| \gamma'_{[[\alpha_{p(i)}(1), \alpha_{q(i)}(0)]} \right|$$

Summing over  $i$ , we obtain

$$\begin{aligned} \sum_{i=1}^m |\gamma'_i| &\leq \sum_{i=1}^m \left( |\alpha_{p(i)}| + |\alpha_{q(i)}| \right) + \sum_{i=1}^m \left| \gamma'_{[\alpha_{p(i)}(1), \alpha_{q(i)}(0)]} \right| \\ &\leq 2 \sum_{j=0}^t |\alpha_{i_j}| + \sum_{i=1}^m \left| \gamma'_{[\alpha_{p(i)}(1), \alpha_{q(i)}(0)]} \right| \leq 2 \sum_{j=0}^t |\alpha_{i_j}| + |\gamma'| \leq 2|\gamma'| + |\gamma'| = 3|\gamma'|. \end{aligned}$$

The claim is confirmed.

Let  $S_i$  be the component of  $\Phi(S)$  that the image of  $\sigma_i$  under the covering map belongs to. We have the length of  $\sigma_i$  in  $\tilde{S}$  is no more than  $\tilde{\delta}_{S_i}(2R + |\gamma'_i|)$ . Thus the sum of the lengths of  $\sigma_i$  in  $\tilde{S}$  is no more than

$$\tilde{\delta}_{S_1}(2R + |\gamma'_1|) + \cdots + \tilde{\delta}_{S_m}(2R + |\gamma'_m|)$$

which is less than or equal to  $\tau(2Rm + \sum_{i=1}^m |\gamma'_i|)$ . Since  $\sum_{i=1}^m |\gamma'_i| \leq 3|\gamma'| \leq 3KRn$  and  $m$  is bounded above by a linear function in term of  $n$  ( $m \leq k \leq n/\rho$ ), it follows that  $|\beta|_{\tilde{S}} \preceq \bar{\tau}(n)$ .  $\square$

## 2.5 Distortion of clean almost fiber surfaces in mixed manifolds

As we have shown in Section 2.4, distortion of a surface in a non-geometric 3-manifold is determined by the distortion of components of the almost fiber part of the surface. We note that each component of the almost fiber part is a clean almost fiber surface. In this section, we compute the distortion of a clean almost fiber surface  $S$  in  $N$ . The main theorem is the following.

**Theorem 2.5.1.** *Let  $g: (S, s_0) \looparrowright (N, x_0)$  be a clean almost fiber surface in a mixed manifold  $N$ . We assume that all Seifert fibered blocks of  $N$  are non-elementary. Suppose that  $S$  contains at least one geometrically infinite piece. Then the distortion of  $\pi_1(S)$  in  $\pi_1(N)$  is*

exponential if  $\pi_1(S)$  is separable in  $\pi_1(N)$ , and double exponential if  $\pi_1(S)$  is non-separable in  $\pi_1(N)$ .

We recall that  $\pi_1(S)$  is separable in  $\pi_1(N)$  if and only if the spirality of  $S$  is trivial (see Remark 2.3.12). The proof of Theorem 2.5.1 is divided into two parts. The proof of the lower bound of the distortion is given in Subsection 2.5.2 and the proof of the upper bound of the distortion is given by Subsection 2.5.1.

**Set up 2.5.2.** We equip  $N$  with the metric  $d$  as in Subsection 2.3.1, and equip  $S$  with a hyperbolic metric  $d_S$  such that the boundary (if nonempty) is totally geodesic and the simple closed curves of  $\mathcal{T}_g$  are geodesics.

For each piece  $B$  of  $S$ , let  $M$  be the block of  $N$  in which  $B$  is mapped into  $M$ . By Remark 2.3.5, there exists a finite cover  $M_B \rightarrow M$  where  $M_B$  is the mapping torus of a homeomorphism  $\varphi$  of the surface  $B$  such that  $\varphi$  fixes periodic points on  $\partial B$ . Each boundary component  $c$  of  $B$  is mapped into a boundary torus of  $M_B$ , we fix a degeneracy slope on this torus, and denoted it by  $\mathbf{s}_{cB}$ . The pullback of the fibration  $M_B \rightarrow S^1$  by the infinite cyclic covering map  $\mathbb{R} \rightarrow S^1$  is  $B \times \mathbb{R}$  (see the paragraph above Lemma 2.3.16), we identify the universal cover  $\tilde{M}$  with  $\tilde{B} \times \mathbb{R}$ . We also assume that  $\tilde{S} \cap \tilde{M} = \tilde{B} \times \{0\}$ .

## 2.5.1 Upper bound of the distortion

In this subsection, we find the upper bound of the distortion of  $\pi_1(S)$  in  $\pi_1(N)$ .

**Proposition 2.5.3.** *The distortion of  $\pi_1(S)$  in  $\pi_1(N)$  is at most double exponential. Furthermore, if the spirality of  $S$  is trivial then the distortion is at most exponential.*

We use the same strategy as in the upper bound section of Chapter 1 (see Section 6 of Chapter 1) but techniques are different. We briefly discuss here the main difference between this current section and Section 6 in Chapter 1. In the setting of graph manifold, a JSJ torus  $T$  of  $N$  receives two Seifert fibers from the blocks on both sides. In Chapter 1, at any  $y$  in  $\tilde{T}$  (universal cover of  $T$ ), we follow fibers (on both sides) until they meet  $\tilde{S}$ . Note that these

fibers do not match up. In this current section, it is possible that one block containing  $T$  is a Seifert fibered space and the other block containing  $T$  is a hyperbolic block or both the blocks are hyperbolic, thus we will follow degeneracy slopes instead. Moreover, at  $y \in \tilde{T}$ , we need to be specific on which degeneracy slopes we should follow.

We describe here the outline of the proof of Proposition 2.5.3. For each  $n \in \mathbb{N}$ , let  $h \in \pi_1(S, x_0)$  such that  $d(\tilde{x}_0, h(\tilde{x}_0)) \leq n$ . We would like to find an upper bound (either exponential or double exponential) of  $d_{\tilde{S}}(\tilde{x}_0, h(\tilde{x}_0))$  in terms of  $n$ . Choose a path  $\beta$  in  $\tilde{N}$  connecting  $\tilde{x}_0$  to  $h(\tilde{x}_0)$  with  $|\beta| \leq n$  such that  $\beta$  passes through a sequence of blocks  $\tilde{M}_0, \dots, \tilde{M}_k$ , intersecting the plane  $\tilde{T}_j = \tilde{M}_{j-1} \cap \tilde{M}_j$  exactly at one point that is denoted by  $y_j$  with  $j = 1, \dots, k$  if  $k \geq 1$ . There exists a piece  $\tilde{B}_j$  of  $\tilde{S}$  such that  $\tilde{g}(\tilde{B}_j) \subset \tilde{M}_j$ . Let  $\rho$  be the constant given by Remark 2.3.18. We note that  $k \leq n/\rho$ . Let  $c_j$  be the circle in  $\mathcal{T}_g$  that is universally covered by the line  $\tilde{B}_{j-1} \cap \tilde{B}_j$  with  $j = 1, \dots, k$ . Let  $\overleftarrow{\mathfrak{s}}_j = \mathfrak{s}_{c_j B_{j-1}}$  and  $\overrightarrow{\mathfrak{s}}_j = \mathfrak{s}_{c_j B_j}$  be the degeneracy slopes in the corresponding tori  $\overleftarrow{T}'_j$  and  $\overrightarrow{T}'_j$  of the spaces  $M_{B_{j-1}}$  and  $M_{B_j}$  respectively (see Definition 2.3.15). The distortion function  $\Delta$  of  $\tilde{S}$  in  $\tilde{N}$  does not change (up to equivalence in Definition 1.2.7) when we add a linear function in term of  $n$  to  $\Delta$ . Therefore, to make the argument simpler, using Corollary 1.2.10 and modifying  $g$  by a homotopy, we may assume that the lifts of the degeneracy slopes and lines  $\tilde{g}(\ell)$  (where  $\ell$  is a line in  $\mathcal{Q}$  the family of lines that are lifts of loops of  $\mathcal{T}_g$ ) are straight lines in the corresponding planes of  $\tilde{N}$ . The line parallel to a lift of the degeneracy slope  $\overleftarrow{\mathfrak{s}}_j$  in  $\tilde{T}_j$  passing through  $y_j$  intersects  $\tilde{g}(\tilde{S})$  in a unique point which is denoted by  $x_j$ . Similarly, the line parallel to a lift of the degeneracy slope  $\overrightarrow{\mathfrak{s}}_j$  in  $\tilde{T}_j$  passing through  $y_j$  intersect  $\tilde{g}(\tilde{S})$  in one point which is denoted by  $z_j$ .

Similarly as in Chapter 1, we show that  $d_{\tilde{S}}(\tilde{x}_0, h(\tilde{x}_0))$  is dominated by the sum

$$e^n \sum_{j=1}^k e^{d(y_j, x_j) + d(y_j, z_j)}$$

and we analyze the growth of the sequence

$$\begin{aligned}
& d(y_1, x_1), d(y_1, z_1), d(y_2, x_2), \dots, \\
& \qquad d(y_{j-1}, z_{j-1}), d(y_j, x_j), d(y_j, z_j), \dots, \\
& \qquad \qquad \qquad d(y_k, x_k), d(y_k, z_k)
\end{aligned}$$

An upper bound on  $d(y_j, x_j)$  in terms of  $d(y_{j-1}, z_{j-1})$  will be described in Lemma 2.5.5. A relation between  $d(y_j, x_j)$  and  $d(y_j, z_j)$  will be Lemma 2.5.6.

**Remark 2.5.4.** 1. It is possible from the construction above that  $x_j = z_j$ .

2. Using Remark 2.3.7, the fact  $S$  has only finite many pieces, and  $N$  has finite many blocks, we obtain a constant  $L \geq 1$  such that for each piece  $\tilde{B}$  in  $\tilde{S}$ , we have  $d_{\tilde{S}}(u, v) \leq e^{Ld(u,v)+L}$  for any two points  $u$  and  $v$  in  $\tilde{B}$ .

Let  $\overleftarrow{\lambda}_j$  and  $\overrightarrow{\lambda}_j$  be the lengths of path lifts of the degeneracy slopes  $\overleftarrow{\mathbf{s}}_j$  and  $\overrightarrow{\mathbf{s}}_j$  in  $\tilde{N}$  with respect to  $d$ -metric. Let  $\overleftarrow{\ell}_j$  (resp.  $\overrightarrow{\ell}_j$ ) be the line parallel to a lift of the degeneracy slope  $\overleftarrow{\mathbf{s}}_j$  (resp.  $\overrightarrow{\mathbf{s}}_j$ ) in  $\tilde{T}_j$  such that  $y_j \in \overleftarrow{\ell}_j$  (resp.  $y_j \in \overrightarrow{\ell}_j$ ). We note that  $\overleftarrow{\ell}_j$  intersects  $\tilde{S}$  at  $x_j$ , and  $\overrightarrow{\ell}_j$  intersects  $\tilde{S}$  at  $z_j$ .

**Lemma 2.5.5** (Crossing a block). *There exists a positive constant  $L'$  such that the following holds: For any  $j = 1, \dots, k$*

$$d(y_j, x_j) \leq \frac{\overleftarrow{\lambda}_j}{\lambda_{j-1}} d(y_{j-1}, z_{j-1}) + L' d(y_j, y_{j-1})$$

*Proof.* We recall that the finite covering space  $M_{B_{j-1}}$  of  $M_{j-1}$  is fibered over circle with the fiber  $B_{j-1}$ , and the block  $\tilde{M}_{j-1}$  is identified with  $\tilde{B}_{j-1} \times \mathbb{R}$ .

We recall that the line  $\overrightarrow{\ell}_{j-1}$  parallel to a lift of the degeneracy slope  $\overrightarrow{\mathbf{s}}_{j-1}$  and  $\overrightarrow{\ell}_{j-1}$  passes through  $y_{j-1}$  and  $z_{j-1}$ . On the line  $\overrightarrow{\ell}_{j-1}$ , choose a point  $u_{j-1}$  such that  $u_{j-1} \in \tilde{B}_{j-1} \times \{n\}$

for some integer  $n$ ,  $d(u_{j-1}, y_{j-1}) \leq \overrightarrow{\lambda_{j-1}}$  and

$$d(u_{j-1}, z_{j-1}) \leq d(y_{j-1}, z_{j-1}) \quad (2.1)$$

Similarly, on the line  $\overleftarrow{\ell}_j$ , choose a point  $v_j \in \tilde{B}_{j-1} \times \{m\}$  for some integer  $m$  and  $v_j$  such that  $d(v_j, y_j) \leq \overleftarrow{\lambda}_j$ . It follows that

$$\begin{aligned} d(u_{j-1}, v_j) &\leq d(u_{j-1}, y_{j-1}) + d(y_{j-1}, y_j) + d(y_j, v_j) \\ &\leq \overrightarrow{\lambda_{j-1}} + d(y_{j-1}, y_j) + \overleftarrow{\lambda}_j \end{aligned} \quad (2.2)$$

Let  $\rho > 0$  be the constant given by Remark 2.3.18. Let  $L$  and  $C$  be constants given by Lemma 2.3.16. We use Lemma 2.3.16 and the fact  $\rho \leq d(u_{j-1}, v_j)$  to see that

$$\begin{aligned} |m - n| &\leq L d(u_{j-1}, v_j) + C \\ &\leq L d(u_{j-1}, v_j) + \frac{C}{\rho} d(u_{j-1}, v_j) \\ &= \left(L + \frac{C}{\rho}\right) d(u_{j-1}, v_j) \end{aligned} \quad (2.3)$$

Let  $L_j = \overleftarrow{\lambda}_j (L + C/\rho) + \overleftarrow{\lambda}_j/\rho + ((\overleftarrow{\lambda}_j)^2 + \overrightarrow{\lambda_{j-1}} \overleftarrow{\lambda}_j)(L + C/\rho)(1/\rho)$ .

We use (2.1), (2.2), (2.3) and the facts  $d(y_j, v_j) \leq \overleftarrow{\lambda}_j$ ,  $d(v_j, x_j) = |m| \overleftarrow{\lambda}_j$  and  $1 \leq$

$d(y_{j-1}, y_j)/\rho$  to see that

$$\begin{aligned}
d(y_j, x_j) &\leq d(y_j, v_j) + d(v_j, x_j) \leq \overleftarrow{\lambda}_j + d(v_j, x_j) \leq \overleftarrow{\lambda}_j + |m| \overleftarrow{\lambda}_j \\
&\leq \overleftarrow{\lambda}_j + |n| \overleftarrow{\lambda}_j + |m - n| \overleftarrow{\lambda}_j \\
&= \overleftarrow{\lambda}_j + \frac{\overleftarrow{\lambda}_j}{\lambda_{j-1}} d(u_{j-1}, z_{j-1}) + |m - n| \overleftarrow{\lambda}_j \\
&\leq \overleftarrow{\lambda}_j + \frac{\overleftarrow{\lambda}_j}{\lambda_{j-1}} d(u_{j-1}, z_{j-1}) + (L + \frac{C}{\rho}) \overleftarrow{\lambda}_j d(u_{j-1}, v_j) \quad \text{by (2.3)} \\
&\leq \overleftarrow{\lambda}_j + \frac{\overleftarrow{\lambda}_j}{\lambda_{j-1}} d(y_{j-1}, z_{j-1}) + (L + \frac{C}{\rho}) \overleftarrow{\lambda}_j d(u_{j-1}, v_j) \\
&\leq \overleftarrow{\lambda}_j + \frac{\overleftarrow{\lambda}_j}{\lambda_{j-1}} d(y_{j-1}, z_{j-1}) + (L + \frac{C}{\rho}) \overleftarrow{\lambda}_j (\overrightarrow{\lambda}_{j-1} + d(y_{j-1}, y_j) + \overleftarrow{\lambda}_j) \\
&= \frac{\overleftarrow{\lambda}_j}{\lambda_{j-1}} d(y_{j-1}, z_{j-1}) + \overleftarrow{\lambda}_j + (L + \frac{C}{\rho}) \overleftarrow{\lambda}_j (\overrightarrow{\lambda}_{j-1} + \overleftarrow{\lambda}_j) + (L + \frac{C}{\rho}) \overleftarrow{\lambda}_j d(y_{j-1}, y_j) \\
&\leq \frac{\overleftarrow{\lambda}_j}{\lambda_{j-1}} d(y_{j-1}, z_{j-1}) + \left( \overleftarrow{\lambda}_j + (L + \frac{C}{\rho}) \overleftarrow{\lambda}_j (\overrightarrow{\lambda}_{j-1} + \overleftarrow{\lambda}_j) \right) \frac{d(y_{j-1}, y_j)}{\rho} \\
&\quad + (L + \frac{C}{\rho}) \overleftarrow{\lambda}_j d(y_{j-1}, y_j) \\
&= \frac{\overleftarrow{\lambda}_j}{\lambda_{j-1}} d(y_{j-1}, z_{j-1}) + L_j d(y_j, y_{j-1})
\end{aligned}$$

Because there are only finitely many pieces of  $S$  and blocks of  $N$ , we can choose a constant  $L'$  (may be maximum of all possible constants  $L_j$ ) that is large enough to satisfy the conclusion of the lemma.  $\square$

**Lemma 2.5.6** (Crossing a JSJ plane).

$$\frac{d(y_j, z_j)}{d(y_j, x_j)} = \xi_j \cdot \frac{\overrightarrow{\lambda}_j}{\overleftarrow{\lambda}_j}$$

*Proof.* Choose non-zero integers  $n$  and  $m$  such that the slice  $\tilde{B}_{j-1} \times \{n\}$  of  $\tilde{M}_{j-1} = \tilde{M}_{B_{j-1}}$  is glued into the slice  $\tilde{B}_j \times \{m\}$  of  $\tilde{M}_j = \tilde{M}_{B_j}$ . Choose a point  $y'$  in  $\tilde{B}_{j-1} \times \{n\}$ , and two points  $x'$  and  $z'$  in  $\tilde{S} \cap \tilde{T}_j$  such that  $[y', z']$  and  $[y_j, z_j]$  are parallel segments as well as  $[y', x']$

and  $[y_j, x_j]$  are parallel segments. Since  $\Delta(x', y', z')$  and  $\Delta(x_j, y_j, z_j)$  are similar triangles, it follows that

$$d(y', z')/d(y', x') = d(y_j, z_j)/d(y_j, x_j)$$

Thus, without loss of generality, we may assume that  $y_j$  belongs to the slice  $\tilde{B}_j \times \{m\}$ , and  $x_j$  belongs to the slice  $\tilde{B}_{j-1} \times \{n\}$ . We note that

$$|n|[\overleftarrow{T}'_j : \overleftarrow{T}_j] = |m|[\overrightarrow{T}'_j : \overrightarrow{T}_j]$$

Thus

$$|m|/|n| = [\overleftarrow{T}'_j : \overleftarrow{T}_j]/[\overrightarrow{T}'_j : \overrightarrow{T}_j] = \xi_j$$

Since  $d(y_j, z_j) = |m| \overrightarrow{\lambda}_j$  and  $d(y_j, x_j) = |n| \overleftarrow{\lambda}_j$ , we have

$$\frac{d(y_j, z_j)}{d(y_j, x_j)} = \xi_j \cdot \frac{\overrightarrow{\lambda}_j}{\overleftarrow{\lambda}_j}$$

□

*Proof of Proposition 2.5.3.* We assume that the base point  $s_0$  belongs to a curve in the collection  $\mathcal{T}_g$ . For any  $h \in \pi_1(S, s_0)$  such that  $d(\tilde{s}_0, h(\tilde{s}_0)) \leq n$ , we will show that  $d_{\tilde{S}}(\tilde{s}_0, h(\tilde{s}_0))$  is bounded above by a double exponential function in terms of  $n$ . Let  $L$  be the constant given by Remark 2.5.4, and let  $L'$  be the constant given by Lemma 2.5.5. We consider the following cases:

**Case 1:**  $\tilde{s}_0$  and  $h(\tilde{s}_0)$  belong to the same a piece  $\tilde{B}$ . By Remark 2.3.7 then  $d_{\tilde{S}}(\tilde{s}_0, h(\tilde{s}_0)) \leq e^{Ln+L}$  which is dominated by an exponential function.

**Case 2:**  $\tilde{s}_0$  and  $h(\tilde{s}_0)$  belong to distinct pieces of  $\tilde{S}$ . Let  $y_j, x_j$ , and  $z_j$  be points described as in the previous paragraphs. For convenience, relabel  $\tilde{s}_0$  by  $y_0$ , and  $h(\tilde{s}_0)$  by  $y_{k+1}$ .

**Claim 1:** Let  $z_0 = y_0$  and  $z_{k+1} = y_{k+1}$ . We have the following inequality.

$$d_{\tilde{S}}(\tilde{s}_0, h(\tilde{s}_0)) \leq e^{Ln} \sum_{j=0}^k e^{Ld(z_j, y_j) + Ld(z_{j+1}, y_{j+1}) + L}$$

We write  $\beta = \beta_0 \cdot \beta_1 \cdots \beta_k$  where  $\beta_j$  is the subpath of  $\beta$  in  $\tilde{M}_j$  connecting  $y_j$  to  $y_{j+1}$ . For each  $j = 0, \dots, k$  we have

$$\begin{aligned} d(z_j, z_{j+1}) &\leq d(z_j, y_j) + d(y_j, y_{j+1}) + d(y_{j+1}, z_{j+1}) \\ &\leq d(z_j, y_j) + |\beta_j| + d(y_{j+1}, z_{j+1}) \end{aligned}$$

Using Remark 2.5.4 we obtain

$$\begin{aligned} d_{\tilde{S}}(\tilde{s}_0, h(\tilde{s}_0)) &= d_{\tilde{S}}(y_0, y_{k+1}) \leq \sum_{j=0}^k d_{\tilde{S}}(z_j, z_{j+1}) \leq \sum_{j=0}^k e^{Ld(z_j, z_{j+1}) + L} \\ &\leq \sum_{j=0}^k e^{L(d(z_j, y_j) + |\beta_j| + d(z_{j+1}, y_{j+1})) + L} \\ &\leq \sum_{j=0}^k e^{L(d(z_j, y_j) + n + d(z_{j+1}, y_{j+1})) + L} \\ &\leq e^{Ln} \sum_{j=0}^k e^{L(d(z_j, y_j) + d(z_{j+1}, y_{j+1})) + L} \end{aligned}$$

Claim 1 is confirmed.

We note that if  $F(n) \sim e^{e^n}$ , and  $E(n) \sim e^n$  then  $e^n F(n) \sim e^{e^n}$  and  $e^n E(n) \sim e^n$ . To complete the proof of the proposition, it suffices to find an appropriate upper bound of the sum appearing in Claim 1 which is a double exponential function in general, and exponential function when the spirality of  $S$  is trivial.

By Lemma 2.5.5, we have

$$d(y_j, x_j) \leq \overleftarrow{\lambda}_j d(y_{j-1}, z_{j-1}) + L' |\beta_{j-1}| \quad (*)$$

By Lemma 2.5.6, we have

$$d(y_j, z_j) = \xi_j \cdot \frac{\overrightarrow{\lambda_j}}{\overleftarrow{\lambda_j}} d(y_j, x_j) \quad (\dagger)$$

**Claim 2:** Suppose that the spirality of  $S$  is non-trivial. There exists a function  $F$  not depending on  $\beta$ ,  $n$ , and  $h$  such that

$$\sum_{j=0}^k e^{Ld(z_j, y_j) + Ld(z_{j+1}, y_{j+1}) + L} \leq F(n)$$

and  $F(n) \sim e^{e^n}$

Let  $\epsilon$  be the governor of  $g$  with respect to the chosen mapping tori (see Definition 2.3.11). Since the spirality of  $S$  is non-trivial, it follows that  $\epsilon$  is strictly greater than 1. Let  $\mathcal{D}$  be the collection of the degeneracy slopes given by Set up 2.5.2. We note that  $\mathcal{D}$  is a finite collection. For each degeneracy slope  $\mathbf{s}_{cB}$ , let  $|\mathbf{s}_{cB}|$  be the length of path lift of  $\mathbf{s}_{cB}$  in  $\tilde{N}$  with respect to  $d$ -metric. Let  $\delta$  be the maximum of all possible ratios  $|\mathbf{s}_{cB}|/|\mathbf{s}_{c'B'}|$ .

We will show that for each  $j = 0, \dots, k$  then

$$d(y_j, z_j) \leq \frac{L'\delta n}{\epsilon - 1} \epsilon^{j+1} \quad (2.4)$$

To see (2.4), we first show by induction on  $j = 0, \dots, k$  that

$$d(y_j, z_j) \leq L'n \sum_{i=1}^j \frac{\overrightarrow{\lambda_j}}{\overleftarrow{\lambda_{j+1-i}}} \epsilon^i$$

The base case is trivial since  $y_0 = z_0$ , so both sides of the inequality equal zero. For inductive

step, we use (\*), (†), the inequality  $\xi_j \leq \epsilon$ , and the fact  $|\beta_{j-1}| \leq n$  to see that

$$\begin{aligned}
d(y_j, z_j) &= \xi_j \frac{\overrightarrow{\lambda_j}}{\overleftarrow{\lambda_j}} d(y_j, x_j) \leq \epsilon \frac{\overrightarrow{\lambda_j}}{\overleftarrow{\lambda_j}} d(y_j, x_j) \leq \epsilon \frac{\overrightarrow{\lambda_j}}{\overleftarrow{\lambda_j}} \left( \frac{\overleftarrow{\lambda_j}}{\overrightarrow{\lambda_{j-1}}} d(y_{j-1}, z_{j-1}) + L' |\beta_{j-1}| \right) \\
&\leq \epsilon \frac{\overrightarrow{\lambda_j}}{\overrightarrow{\lambda_{j-1}}} d(y_{j-1}, z_{j-1}) + \epsilon \frac{\overrightarrow{\lambda_j}}{\overleftarrow{\lambda_j}} L' |\beta_{j-1}| \\
&\leq \epsilon \frac{\overrightarrow{\lambda_j}}{\overrightarrow{\lambda_{j-1}}} d(y_{j-1}, z_{j-1}) + \epsilon \frac{\overrightarrow{\lambda_j}}{\overleftarrow{\lambda_j}} L' n \\
&\leq \epsilon \frac{\overrightarrow{\lambda_j}}{\overrightarrow{\lambda_{j-1}}} L' n \sum_{i=1}^{j-1} \frac{\overrightarrow{\lambda_{j-1}}}{\overleftarrow{\lambda_{j-i}}} \epsilon^i + \epsilon \frac{\overrightarrow{\lambda_j}}{\overleftarrow{\lambda_j}} L' n \\
&= L' n \sum_{i=1}^{j-1} \frac{\overrightarrow{\lambda_j}}{\overleftarrow{\lambda_{j-i}}} \epsilon^{i+1} + \epsilon \frac{\overrightarrow{\lambda_j}}{\overleftarrow{\lambda_j}} L' n = L' n \left( \sum_{i=1}^{j-1} \frac{\overrightarrow{\lambda_j}}{\overleftarrow{\lambda_{j-i}}} \epsilon^{i+1} + \epsilon \frac{\overrightarrow{\lambda_j}}{\overleftarrow{\lambda_j}} \right) \\
&= L' n \left( \sum_{i=2}^j \frac{\overrightarrow{\lambda_j}}{\overleftarrow{\lambda_{j+1-i}}} \epsilon^i + \epsilon \frac{\overrightarrow{\lambda_j}}{\overleftarrow{\lambda_j}} \right) = L' n \sum_{i=1}^j \frac{\overrightarrow{\lambda_j}}{\overleftarrow{\lambda_{j+1-i}}} \epsilon^i
\end{aligned}$$

Since  $\overleftarrow{\lambda_j}/\overleftarrow{\lambda_{j+1-i}}$  is bounded above by  $\delta$ , it follows that

$$d(y_j, z_j) \leq L' n \delta \sum_{i=1}^j \epsilon^i \leq L' n \delta \epsilon^{j+1} / (\epsilon - 1),$$

establishing (2.4). Summing over  $j$ , we obtain

$$\sum_{j=1}^k d(y_j, z_j) \leq \frac{L' \delta n}{\epsilon - 1} (\epsilon^2 + \dots + \epsilon^{k+1}) \leq \frac{L' \delta n \epsilon^2}{(\epsilon - 1)^2} \epsilon^{k+2} \leq \frac{L' \delta n \epsilon^2}{(\epsilon - 1)^2} \epsilon^{n/\rho+2}$$

which is equivalent to an exponential function of  $n$ . We use the facts  $y_0 = z_0$ ,  $y_{k+1} = z_{k+1}$ ,

$L \geq 1$ , and the fact that  $e^x$  is superadditive on  $[1, \infty)$  to see that

$$\begin{aligned}
\sum_{j=0}^k e^{Ld(z_j, y_j) + Ld(z_{j+1}, y_{j+1}) + L} &\leq e^{\sum_{j=0}^k Ld(z_j, y_j) + Ld(z_{j+1}, y_{j+1}) + L} \\
&= e^{(k+1)L + \sum_{j=0}^k Ld(z_j, y_j) + Ld(z_{j+1}, y_{j+1})} \\
&= e^{(k+1)C + 2L \sum_{j=1}^k d(y_j, z_j)} \\
&\leq e^{(n/\rho + 1) + 2L \sum_{j=1}^k d(y_j, z_j)}
\end{aligned}$$

which is equivalent to a double exponential function (because  $\sum_{j=1}^k d(y_j, z_j)$  is equivalent to an exponential function of  $n$ , so  $(n/\rho + 1) + 2L \sum_{j=1}^k d(y_j, z_j)$  is also equivalent to an exponential function of  $n$ ). Claim 2 is confirmed.

**Claim 3:** Suppose the spirality of  $S$  is trivial. There exists a function  $E$  not depending on  $\beta$ ,  $n$ , and  $h$  such that

$$\sum_{j=1}^k e^{Ld(y_j, z_j) + Ld(y_{j+1}, z_{j+1}) + L} \leq E(n)$$

and  $E(n) \sim e^n$ .

For any  $1 \leq i \leq j$ , let  $\Theta_{i,j} = \xi_i \xi_{i+1} \cdots \xi_j$ . Let  $\Lambda$  be the constant given by Proposition 2.3.13. In order to prove Claim 3, we follow the argument in the proof of Claim 3 of Theorem 6.1 in Chapter 1. We note that

$$\Theta_{i,j-1} \xi_j = \Theta_{i,j}$$

We will show by induction on  $j = 0, 1, \dots, k$  that

$$d(y_j, z_j) \leq L' \sum_{i=1}^j |\beta_{i-1}| \frac{\vec{\lambda}_j}{\lambda_i} \Theta_{i,j}$$

The base case  $j = 0$  is trivial since both sides of the inequality equal zero. For the inductive

step, we use (\*), (†) to see that

$$\begin{aligned}
d(y_j, z_j) &= \xi_j \frac{\overrightarrow{\lambda_j}}{\overleftarrow{\lambda_j}} d(y_j, x_j) = d(y_j, x_j) \frac{\overrightarrow{\lambda_j}}{\overleftarrow{\lambda_j}} \xi_j \\
&\leq \left( \frac{\overleftarrow{\lambda_j}}{\overrightarrow{\lambda_{j-1}}} d(y_{j-1}, z_{j-1}) + L' |\beta_{j-1}| \right) \frac{\overrightarrow{\lambda_j}}{\overleftarrow{\lambda_j}} \xi_j \\
&= d(y_{j-1}, z_{j-1}) \frac{\overrightarrow{\lambda_j}}{\overrightarrow{\lambda_{j-1}}} \xi_j + L' |\beta_{j-1}| \frac{\overrightarrow{\lambda_j}}{\overleftarrow{\lambda_j}} \xi_j \\
&\leq \left( L' \sum_{i=1}^{j-1} |\beta_{i-1}| \frac{\overrightarrow{\lambda_{j-1}}}{\overleftarrow{\lambda_i}} \Theta_{i,j-1} \right) \frac{\overrightarrow{\lambda_j}}{\overrightarrow{\lambda_{j-1}}} \xi_j + L' |\beta_{j-1}| \frac{\overrightarrow{\lambda_j}}{\overleftarrow{\lambda_j}} \xi_j \\
&= L' \sum_{i=1}^{j-1} |\beta_{i-1}| \frac{\overrightarrow{\lambda_j}}{\overleftarrow{\lambda_i}} \Theta_{i,j-1} \xi_j + L' |\beta_{j-1}| \frac{\overrightarrow{\lambda_j}}{\overleftarrow{\lambda_j}} \xi_j \\
&= L' \sum_{i=1}^{j-1} |\beta_{i-1}| \frac{\overrightarrow{\lambda_j}}{\overleftarrow{\lambda_i}} \Theta_{i,j} + L' |\beta_{j-1}| \frac{\overrightarrow{\lambda_j}}{\overleftarrow{\lambda_j}} \Theta_{j,j} \\
&= L' \sum_{i=1}^j |\beta_{i-1}| \frac{\overrightarrow{\lambda_j}}{\overleftarrow{\lambda_i}} \Theta_{i,j}
\end{aligned}$$

Since  $\Theta_{i,j}$  is bounded above by  $\Lambda$ ,  $\overrightarrow{\lambda_j}/\overleftarrow{\lambda_i}$  is bounded above by  $\delta$ , and  $\sum_{i=1}^j |\beta_{i-1}| \leq |\beta| \leq n$ , we have

$$d(y_j, z_j) \leq L' \sum_{i=1}^j |\beta_{i-1}| \delta \Lambda = L' \delta \Lambda \sum_{i=1}^j |\beta_{i-1}| \leq L' \delta \Lambda n$$

It follows that

$$e^{Ld(y_j, z_j) + Ld(y_{j+1}, z_{j+1}) + L} \leq e^{2LL'\delta\Lambda n + L}$$

Summing over  $j$ , we obtain

$$\begin{aligned}
\sum_{j=0}^k e^{Ld(y_j, z_j) + Ld(y_{j+1}, z_{j+1}) + L} &\leq \sum_{j=0}^k e^{2LL'\delta\Lambda n + L} = (k+1) e^{2LL'\delta\Lambda n + L} \\
&\leq (n/\rho + 1) e^{2LL'\delta\Lambda n + L}
\end{aligned}$$

which is equivalent to an exponential function of  $n$ , establishing Claim 3.

If the spirality of  $S$  is non-trivial, Claim 1 combines with Claim 2 gives a double expo-

ponential upper bound for  $d_{\tilde{S}}(\tilde{s}_0, h(\tilde{s}_0))$ . If the spirality of  $S$  is trivial, we combine Claim 1 and Claim 3 to get an exponential upper bound. The proposition follows from Corollary 1.2.10.  $\square$

## 2.5.2 Lower bound of the distortion

In this subsection, we compute the lower bound of the distortion of  $\pi_1(S)$  in  $\pi_1(N)$ .

**Proposition 2.5.7.** *The distortion of  $\pi_1(S)$  in  $\pi_1(N)$  is at least exponential.*

*Proof.* We recall that  $S$  contains a geometrically infinite piece. The fundamental group of the geometrically infinite piece is exponentially distorted in the fundamental group of the corresponding hyperbolic block of  $N$  (see Remark 2.3.7). The fundamental group of the geometrically infinite piece is undistorted in  $\pi_1(S)$  (in fact, every finitely generated subgroup of  $\pi_1(S)$  is undistorted), and the fundamental group of the hyperbolic block is undistorted in  $\pi_1(N)$ . We combine these facts and Proposition 2.2.1 to get the proof of this proposition.  $\square$

For the rest of this subsection, we will compute the lower bound (double exponential) of the distortion of  $\pi_1(S)$  in  $\pi_1(N)$  when the spirality of  $S$  is non-trivial.

**Proposition 2.5.8.** *The distortion  $\pi_1(S)$  in  $\pi_1(N)$  is at least double exponential if the spirality of  $S$  is non-trivial.*

**The Goal:** Let  $\tilde{s}_0$  be a lift of  $s_0$  in  $\tilde{S}$ . For convenience, we label  $\tilde{s}_0$  by  $z_1$ . Our goal in this section is to construct a sequence of elements  $\{z_n\}$  in  $\tilde{S}$  such that  $d(z_1, z_n) \leq n$  and  $d_{\tilde{S}}(z_1, z_n)$  is bounded from below by a double exponential function in terms of  $n$ .

**Lemma 2.5.9.** *Let  $\gamma$  be a geodesic loop in  $S$  such that  $\gamma$  and  $\mathcal{T}_g$  have nonempty intersection and such that  $w(\gamma) > 1$ . There exists a positive number  $A = A(\gamma)$  such that the following holds: Let  $\{c_1, \dots, c_m\}$  be the sequence of curves of  $\mathcal{T}_g$  (see Definition 2.3.8) crossed by  $\gamma$ . The image of the circle  $g(c_i)$  in  $M$  lies in a JSJ torus  $T_i$  obtained by gluing to a boundary torus  $\overleftarrow{T}_i$  of  $M_{i-1}$  to a boundary torus  $\overrightarrow{T}_i$  of  $M_i$ . Let  $\overleftarrow{T}_i$  and  $\overrightarrow{T}_i$  be the boundary tori of  $M_{B_{i-1}}$*

and  $M_{B_i}$  where the circle  $c_i$  is embedded into  $\overleftarrow{T}_i$  and  $\overrightarrow{T}_i$  respectively. For each  $i = 1, 2, \dots, m$ , let  $\xi_i = [\overleftarrow{T}_i : \overleftarrow{T}_i] / [\overrightarrow{T}_i : \overrightarrow{T}_i]$ . Extend the sequence  $\xi_1, \dots, \xi_m$  to a periodic sequence  $\{\xi_j\}_{j=1}^\infty$  with  $\xi_{j+m} = \xi_j$  for all  $j > 0$ . Then there exists a (nonperiodic) sequence of integers  $\{t_j\}_{j=1}^\infty$ , depending on our choice of the loop  $\gamma$  such that

1.  $0 \leq t_j/\xi_j - t_{j-1} \leq A$  and  $t_j/\xi_j \in \mathbb{N}$  for all  $j \geq 2$ .

2.  $t_{nm+1} \geq t_1 w(\gamma)^n$  for all  $n \geq 1$ .

3. Let  $\epsilon$  be the governor of  $g$  with respect to the chosen mapping tori. There exists a positive constant  $D$  depending only on  $A, \epsilon$ , and  $t_1$  such that  $t_n \leq e^{Dn+D}$  for all  $n \geq 1$ .

*Proof.* We recall that the spirality of  $\gamma$  is the number  $w(\gamma) = \xi_1 \xi_2 \cdots \xi_m$  (see Definition 2.3.11). For each  $j \in \{1, \dots, m\}$ , let  $p_j = [\overleftarrow{T}_j' : \overleftarrow{T}_j']$  and  $q_j = [\overrightarrow{T}_j' : \overrightarrow{T}_j']$ . Extend the sequence  $p_1, p_2, \dots, p_m$  to a  $m$ -periodic sequence  $\{p_j\}_{j=1}^\infty$  with  $p_{j+m} = p_j$  for all  $j \geq 1$ , and similarly extend  $q_1, \dots, q_m$  to an  $m$ -periodic sequence  $\{q_j\}_{j=1}^\infty$ . Let  $A = \max\{1 + q_j \mid j = 1, 2, \dots, m\}$ . Let  $t(1) = q_1 q_2 \cdots q_m$ , we construct an infinite sequence  $\{t_j\}$  satisfying (1). Suppose that  $t_{j-1}$  has been defined for some  $j \geq 2$ , and we would like to define  $t_j$ . Since  $1 + q_j \leq A$ , we have

$$1 \leq \frac{A-1}{q_j} = \frac{A+t_{j-1}-1-t_{j-1}}{q_j} = \frac{A+t_{j-1}}{q_j} - \frac{1+t_{j-1}}{q_j}$$

It follows that there exists  $k_j \in \mathbb{N}$  such that

$$\frac{1+t_{j-1}}{q_j} \leq k_j \leq \frac{A+t_{j-1}}{q_j} \quad (\clubsuit)$$

Let  $t_j = k_j p_j$ . It is obvious that  $t_j \in \mathbb{N}$ . We use the fact  $\xi_j = p_j/q_j$  to see that  $t_j/\xi_j = k_j p_j/\xi_j = k_j q_j$ . Hence  $t_j/\xi_j \in \mathbb{N}$ .

From  $(\clubsuit)$ , we have  $1 + t_{j-1} \leq k_j q_j \leq A + t_{j-1}$ . Hence  $1 \leq k_j q_j - t_{j-1} \leq A$ . Using  $t_j/\xi_j = k_j q_j$ , we immediately have  $1 \leq t_j/\xi_j - t_{j-1} \leq A$ , verifying (1).

We next verify that the sequence  $\{t_j\}$  in (1) satisfies (2). From (1), we have  $0 \leq t_j/\xi_j - t_{j-1}$ . Thus

$$t_j \geq \xi_j t_{j-1} \quad \text{for all } j > 1. \quad (\diamond)$$

For any  $j > m$ , we apply  $(\diamond)$  iteratively  $m$  times to get

$$\begin{aligned} t_j &\geq \xi_j t_{j-1} \\ &\geq \xi_j \xi_{j-1} t_{j-2} \geq \cdots \\ &\geq \left( \xi_j \xi_{j-1} \cdots \xi_{j-m+1} \right) t_{j-m} \\ &= w(\gamma) t_{j-m} \end{aligned}$$

Further applying  $t_j \geq w(\gamma) t_{j-m}$  iteratively  $k$  times (and using that  $w(\gamma) \geq 1$ ) gives  $t_j \geq w(\gamma)^n t_{j-nm}$  for any  $n \geq 1$ . In particular, with  $j = nm + 1$  we have  $t_{nm+1} \geq w(\gamma)^n t_1$  which confirms (2).

In order to establish (3), we recall that  $w(\gamma) > 1$ . It follows that the spirality of  $S$  is non-trivial. Let  $\epsilon$  be the governor of  $g$  with respect to the chosen mapping torus (see Definition 2.3.11). We note that  $\epsilon$  is strictly greater than 1 since the spirality of  $S$  is non-trivial. We will show by induction on  $j$  that

$$t_j \leq (A + t_1) \sum_{i=1}^j \epsilon^i$$

When  $j = 1$ , it is obvious that  $t_1 < (A + t_1)\epsilon$  (using  $\epsilon > 1$ ). For the inductive step, we use

the right inequality (i.e,  $t_j/\xi_j - t_{j-1} \leq A$ ) in (1), and the fact  $\xi_j \leq \epsilon$  to get that

$$\begin{aligned}
t_j &\leq (A + t_{j-1}) \xi_j \\
&\leq (A + t_{j-1})\epsilon = A\epsilon + t_{j-1}\epsilon \\
&\leq A\epsilon + (A + t_1) \left( \sum_{i=1}^{j-1} \epsilon^i \right) \epsilon = A\epsilon + (A + t_1) \sum_{i=1}^{j-1} \epsilon^{i+1} \\
&< (A + t_1)\epsilon + (A + t_1) \sum_{i=1}^{j-1} \epsilon^{i+1} \\
&= (A + t_1) \left( \epsilon + \sum_{i=1}^{j-1} \epsilon^{i+1} \right) = (A + t_1) \sum_{i=1}^j \epsilon^i
\end{aligned}$$

Since  $\sum_{i=1}^j \epsilon^i < \epsilon^{j+1}/(\epsilon - 1)$ , we obtain  $t_j < (A + t_1)\epsilon^{j+1}/(\epsilon - 1)$ . It follows that there is  $D > 0$  depending only on  $A$ ,  $\epsilon$  and  $t_1$  such that  $t_j \leq e^{Dj+D}$  for all  $j \geq 1$  (for example, we may choose  $D = \ln(\epsilon) + \ln(A + t_1)\epsilon/(\epsilon - 1)$ ).  $\square$

For the rest of this section, we fix the curve  $\gamma$  satisfying the hypothesis of Lemma 2.5.9. The collection  $\mathcal{T}_\gamma$  subdivides  $\gamma$  into a concatenation  $\gamma_1 \cdots \gamma_m$  with the following properties. Each path  $\gamma_i$  belongs to a piece  $B_i$  of  $S$ , starting on a circle  $c_i \in \mathcal{T}_\gamma$  and ending on the circle  $c_{i+1}$ . The image  $g(\gamma_i)$  of this path in  $N$  lies in a block  $M_i$ . The image of the circle  $g(c_i)$  in  $N$  lies a JSJ torus  $T_i$  obtained by gluing to a boundary torus  $\overleftarrow{T}_i$  of  $M_{i-1}$  to a boundary torus  $\overrightarrow{T}_i$  of  $M_i$ . We extend the sequence  $\gamma_1, \dots, \gamma_m$  to a periodic sequence  $\{\gamma_j\}_{j=1}^\infty$  with  $\gamma_{j+m} = \gamma_j$  for all  $j \geq 1$ . We extend the sequence  $c_1, \dots, c_m$  to a periodic sequence  $\{c_j\}_{j=1}^\infty$  with  $c_{j+m} = c_j$  for all  $j \geq 1$ . We also choose the basepoint  $x_0 \in S$  to be the initial point of  $\gamma_1$ . Let  $\mathcal{Q}$  be the family of lines that are lifts of loops of  $\mathcal{T}_\gamma$ .

**construction 2.5.10** (Constructing a sequence of points in  $\tilde{S}$ ). We recall that  $\tilde{g}: \tilde{S} \rightarrow \tilde{N}$  is an embedding. Let  $\tilde{x}_0 = \tilde{g}(\tilde{s}_0)$ . For convenience, we relabel  $\tilde{x}_0$  by  $z_1$ . Draw a line that passes through  $z_1$  parallel to a lift of the degeneracy slope  $\overrightarrow{\mathbf{s}}_1 = \mathbf{s}_{c_1 B_1}$  in  $\tilde{M}_1 = \tilde{M}_{B_1}$ . We denote the intersection of this line with the slice  $\tilde{B}_1 \times \{t_1\}$  (of  $\tilde{M}_1 = \tilde{M}_{B_1}$ ) by  $y_1$ . We denote the degeneracy slope  $\mathbf{s}_{c_1 B_m}$  by  $\overleftarrow{\mathbf{s}}_1$ . Let  $x_1 = z_1$ . We construct a sequence of triples  $\{x_j, y_j, z_j\}$

inductively as the following.

Suppose that  $y_{j-1}$ ,  $x_{j-1}$ , and  $z_{j-1}$  have been defined. Let  $\tilde{\gamma}_{j-1}$  be the lift of  $\gamma_{j-1}$  in  $\tilde{N}$  based at  $y_{j-1}$ . Let  $y'_j$  be the terminal point of  $\tilde{\gamma}_{j-1}$ . Draw a line that passes through  $y'_j$  parallel to a lift of the degeneracy slope  $\overleftarrow{\mathbf{s}}_j = \mathbf{s}_{c_j B_{j-1}}$  in  $\tilde{M}_{j-1} = \tilde{M}_{B_{j-1}}$ . This line meets the slice  $\tilde{B}_{j-1} \times \{0\} \subset \tilde{S}$  at a point denoted by  $x_j$ , and it meets the slice  $\tilde{B}_{j-1} \times \{t_j/\xi_j\}$  in  $\tilde{M}_{j-1} = \tilde{M}_{B_{j-1}}$  at a point denoted by  $y_j$ . Draw a line that passes through  $y_j$  parallel to a lift of the degeneracy slope  $\overrightarrow{\mathbf{s}}_j = \mathbf{s}_{c_j B_j}$  in  $\tilde{M}_j = \tilde{M}_{B_j}$  until it meets the slice  $\tilde{B}_j \times \{0\} \subset \tilde{S}$  at a point denoted by  $z_j$ .

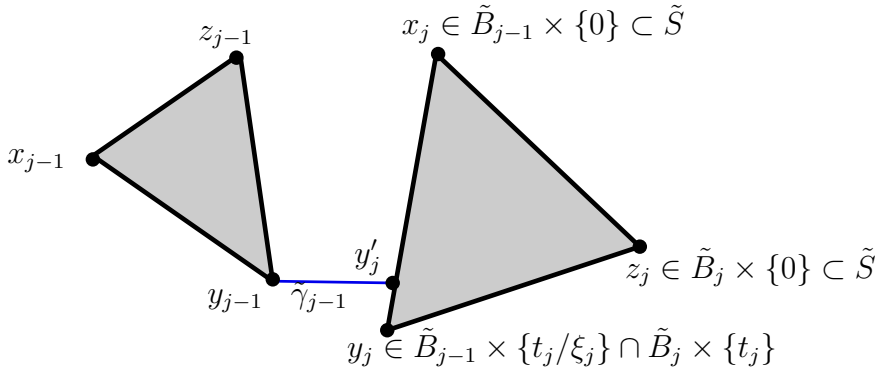

Figure 2.2: The picture illustrates the slices that  $x_j$ ,  $y_j$ ,  $z_j$  belong to

In the following, let  $\{x_j\}$ ,  $\{y_j\}$ , and  $\{z_j\}$  be the collections of points given by Construction 2.5.10. We note that  $z_j \in (\tilde{B}_{j-1} \times \{0\}) \cap (\tilde{B}_j \times \{0\})$ . We denote  $\overleftarrow{\lambda}_i$  the length of the image of  $\overleftarrow{\mathbf{s}}_i$  in  $N$ , and  $\overrightarrow{\lambda}_i$  the length of the image of  $\overrightarrow{\mathbf{s}}_i$  in  $N$  with  $i = 1, \dots, m$ . We extend the sequence  $\overleftarrow{\lambda}_1, \dots, \overleftarrow{\lambda}_m$  to the  $m$ -periodic sequence  $\{\overleftarrow{\lambda}_j\}_{j=1}^\infty$ , and the sequence  $\overrightarrow{\lambda}_1, \dots, \overrightarrow{\lambda}_m$  to the  $m$ -periodic sequence  $\{\overrightarrow{\lambda}_j\}_{j=1}^\infty$ .

**Remark 2.5.11.** From Construction 2.5.10, it is possible that  $x_j = z_j$ . For each  $j \geq 2$ , since  $y_j$  belongs to the slice  $\tilde{B}_{j-1} \times \{t_j/\xi_j\}$  of  $\tilde{M}_{j-1}$ , we have  $d(y_j, x_j) = \frac{t_j}{\xi_j} \overleftarrow{\lambda}_j$ . Also  $y_j$  belongs to the slice  $\tilde{B}_j \times \{t_j\}$  of  $\tilde{M}_j$  (see Lemma 2.5.6 for a similar argument), and thus  $d(y_j, z_j) = t_j \overrightarrow{\lambda}_j$ .

Since  $y'_j \in \tilde{B}_{j-1} \times \{t_{j-1}\}$ , it follows that  $d(x_j, y'_j) = t_{j-1} \overleftarrow{\lambda}_j$ . Thus  $d(y_j, y'_j) = d(y_j, x_j) - d(x_j, y'_j) = \frac{t_j}{\xi_j} \overleftarrow{\lambda}_j - t_{j-1} \overleftarrow{\lambda}_j = (\frac{t_j}{\xi_j} - t_{j-1}) \overleftarrow{\lambda}_j$

We use the following lemma in the proof of Lemma 2.5.16 where we show that the double

spiral path  $\sigma_n$  in Definition 2.5.13 is non-backtracking.

**Lemma 2.5.12.** *Let  $F$  be a connected compact hyperbolic surface with non-empty boundary. Equip  $F$  with a hyperbolic metric and lift this metric to the universal cover  $\tilde{F}$ , and denote it by  $d$ . There exists a constant  $k > 0$  such that the following holds:*

*Let  $\ell$  and  $\ell'$  be two distinct boundary lines in  $\tilde{F}$ . Let  $[p, p']$  be a geodesic of shortest length from  $\ell$  to  $\ell'$ . Let  $c_1$  be the boundary circle in  $F$  such that  $\ell'$  covers  $c_1$ . Let  $z$  be a point in  $\ell$ ,  $\beta$  be the geodesic in  $\tilde{F}$  connecting  $z$  to  $p'$ , and  $\tilde{c}_1^k$  be the path lift of  $c_1^k$  based at  $p'$ . Let  $\beta^{-1}$  be the path lift of the image of the inverse path  $\bar{\beta}$  (of  $\beta$ ) based at  $\tilde{c}_1^k(1)$ . Then the terminal point of the path  $\beta \cdot \tilde{c}_1^k \cdot \beta^{-1}$  does not lie in the boundary line  $\ell$ .*

*Proof.* We note that  $(\tilde{F}, d)$  is bilipschitz homeomorphic to a fattened tree (see the paragraph after Lemma 1.1 [BN08]). Thus, there exists  $\epsilon > 0$  such that the following holds: Let  $\ell_0$  and  $\ell_1$  be two distinct boundary lines in  $\tilde{F}$ . Let  $[p_0, p_1]$  be a geodesic of shortest length from  $\ell_0$  to  $\ell_1$ . Then every geodesic from  $\ell_0$  to  $\ell_1$  must come within a distance  $\epsilon$  of both  $p_0$  and  $p_1$ . Let  $\delta$  be the maximum of values  $|c|$  with  $c$  varying over all boundary circles of  $F$ . Let  $k$  be a sufficiently large integer such that  $k\delta > 2\epsilon$ .

Suppose by way of contradiction that the terminal point of  $\beta \cdot \tilde{c}_1^k \cdot \beta^{-1}$  lies in  $\ell$ . Let  $h = [c_1^k] \in \pi_1(F, *)$  where  $*$   $\in c_1$  is the image of  $p'$  under the covering map. We note that  $\beta^{-1} = h(\bar{\beta})$ ,  $h(p') \in \ell'$ , and  $p, z \in \ell$ . Since we assume that  $\beta^{-1}(1) \in \ell$ , it follows that  $h(z) = \beta^{-1}(1) \in \ell$ . Since  $z, p \in \ell$ , it follows that  $h(p) \in \ell$ . Let  $[h(p), h(p')]$  be the geodesic in  $\tilde{F}$  connecting  $h(p) \in \ell$  to  $h(p') \in \ell'$ . According to the previous paragraph, it follows that there exists  $a \in [h(p), h(p')]$  such that  $d(p', a) \leq \epsilon$ . Since the concatenation  $[h(p), a] \cdot [a, p']$  is a path from  $\ell$  to  $\ell'$  and  $[p, p']$  is a geodesic of shortest length from  $\ell$  to  $\ell'$ , it follows that  $d(p, p') = |[p, p']| \leq |[h(p), a] \cdot [a, p']| = d(h(p), a) + d(a, p') \leq d(h(p), a) + \epsilon$ .

Using the fact  $d(h(p), h(p')) = d(p, p')$ ,  $a \in [h(p), h(p')]$ , and the inequality  $d(p, p') \leq d(h(p), a) + \epsilon$ , we have

$$d(a, h(p')) = d(h(p), h(p')) - d(a, h(p)) = d(p, p') - d(a, h(p)) \leq \epsilon$$

It follows that

$$k\delta \leq k|c_1| = |\tilde{c}_1^k| = d(p', h(p')) \leq d(p', a) + d(a, h(p')) \leq \epsilon + d(a, h(p')) \leq 2\epsilon$$

This contradicts to our choice of  $k$  that  $k\delta > 2\epsilon$ .  $\square$

We recall that  $\mathcal{Q}$  is the family of lines in  $\tilde{S}$  that are lifts of curves of  $\mathcal{T}_g$ . We also recall that both  $z_j$  and  $z_{j+1}$  belong  $\tilde{B}_j$ . For each  $j$ , let  $\ell_j$  be the line in  $\mathcal{Q}$  that passes through  $z_j$ . Let  $\alpha_j$  be a shortest path in  $\tilde{B}_j$  connecting  $\ell_j$  to  $\ell_{j+1}$  of  $\tilde{B}_j$ . For each piece  $B$  of  $S$ , let  $k_B$  be the constant given by Lemma 2.5.12. Let  $k_0$  be the maximum of  $k_B$  where  $B$  runs over pieces of  $S$ .

**Definition 2.5.13** (Double spiral path). Let  $[z_j, z_{j+1}]$  be a geodesic in  $\tilde{S}$  connecting  $z_j$  to  $z_{j+1}$ , and  $[z_j, \alpha_j(1)]$  a geodesic in  $\tilde{S}$  connecting  $z_j$  to  $\alpha_j(1)$ . For each  $n \geq 1$ , let  $\tau_n$  be the concatenation of the geodesics

$$[z_1, z_2], [z_2, z_3], \dots, [z_{nm-1}, z_{nm}], [z_{nm}, \alpha_{nm}(1)]$$

Let  $\tilde{c}_1^{k_0}$  be the path lift of  $c_1^{k_0}$  based at  $\alpha_{nm}(1)$ . We define *double spiral path*  $\sigma_n$  of  $\tau_n$  as

$$\sigma_n = \tau_n \cdot \tilde{c}_1^{k_0} \cdot \tau_n^{-1}$$

**Lemma 2.5.14.** *Suppose that  $M_1$  is a hyperbolic block of  $N$ . Then there exists an integer  $n_1$ , a function  $F(n)$  such that  $F(n) \sim e^{\epsilon^n}$ , and  $F(n) \leq |\alpha_{nm+1}|_{\tilde{S}}$  for all  $n \geq n_1$ .*

*Proof.* We recall that  $M_{B_1}$  is the mapping torus of a pseudo-Anosov  $\varphi: B_1 \rightarrow B_1$ . By our assumption, we note that  $M_{nm+1} = M_1$  and  $M_1$  is a hyperbolic block of  $N$ . Applying Lemma 2.3.17 to the pseudo-Anosov  $\varphi$  and the curve  $\gamma_1$ , there exists a sufficiently large integer  $n_0$  such that the following holds: For any  $j \geq n_0$ , let  $u_j$  and  $v_j$  be the two endpoints of a path lift of  $\varphi^j(\gamma_1)$  in the universal cover  $\tilde{B}_1$ . Let  $\alpha$  be a shortest path in  $\tilde{B}_1$  from a

boundary line of  $\partial\tilde{B}_1$  that contains  $u_j$  to a boundary line of  $\partial\tilde{B}_1$  that contains  $v_j$ . Then

$$e^{Lj}/C \leq d_{\tilde{S}}(u_j, v_j), \frac{\ln d_{\tilde{S}}(u_j, \alpha(0))}{n} \leq \frac{1}{2}, \text{ and } \frac{\ln d_{\tilde{S}}(v_j, \alpha(1))}{n} \leq \frac{1}{2} \quad (*)$$

By (2) in Lemma 2.5.9, we have  $(w(\gamma))^n t_1 \leq t_{nm+1}$ . Hence, there exists an integer  $n_1$  which is greater than  $n_0$  and satisfies that  $n_0 \leq (w(\gamma))^n t_1 \leq t_{nm+1}$  for all  $n \geq n_1$ . Let  $F$  be a function on  $n$  defined by  $F(n) = e^{Lt_1 w(\gamma)^n} / C - 2e^{n/2}$ . We note that  $w(\gamma) > 1$ , thus  $F(n) \sim e^{e^n}$  (we recall that if  $a, b > 1$  then  $a^{b^n} \sim e^{e^n}$ ). To prove the lemma, we first prove the following claim.

**Claim:**  $F(n) \leq d_{\tilde{S}}(z_{nm+1}, \alpha_{nm+1}(1)) - e^{n/2}$  for all  $n \geq n_1$ .

We recall that  $\alpha_{nm+1}$  is a shortest path connecting  $\ell_{nm+1}$  to  $\ell_{nm+2}$ . Let  $\widetilde{\varphi^{t_{nm+1}}(\gamma_1)}$  be the path lift of  $\varphi^{t_{nm+1}}(\gamma_1)$  based at  $z_{nm+1}$ . We denote the initial point and terminal point of  $\widetilde{\varphi^{t_{nm+1}}(\gamma_1)}$  by  $u_{t_{nm+1}}$  and  $v_{t_{nm+1}}$  respectively. We have that  $v_{nm+1} \in \ell_{nm+2}$  (we refer the reader to Lemma 2.5.15 for an explanation of this fact). Using (\*), the fact  $z_{nm+1} = u_{t_{nm+1}}$ , and the triangle inequality, we have

$$\begin{aligned} F(n) &= e^{Lt_1 w(\gamma)^n} / C - 2e^{n/2} \leq e^{Lt_{nm+1}} / C - 2e^{n/2} \\ &\leq d_{\tilde{S}}(u_{t_{nm+1}}, v_{t_{nm+1}}) - 2e^{n/2} \quad (\text{using the first inequality of } (*)) \\ &= d_{\tilde{S}}(z_{nm+1}, v_{t_{nm+1}}) - 2e^{n/2} \\ &\leq d_{\tilde{S}}(z_{nm+1}, \alpha_{nm+1}(1)) + d_{\tilde{S}}(\alpha_{nm+1}(1), v_{t_{nm+1}}) - 2e^{n/2} \\ &\leq d_{\tilde{S}}(z_{nm+1}, \alpha_{nm+1}(1)) + e^{n/2} - 2e^{n/2} \quad (\text{using the third inequality of } (*)) \\ &= d_{\tilde{S}}(z_{nm+1}, \alpha_{nm+1}(1)) - e^{n/2} = d_{\tilde{S}}(u_{t_{nm+1}}, \alpha_{nm+1}(1)) - e^{n/2} \\ &\leq d_{\tilde{S}}(u_{t_{nm+1}}, \alpha_{nm+1}(0)) + d_{\tilde{S}}(\alpha_{nm+1}(0), \alpha_{nm+1}(1)) - e^{n/2} \\ &\leq e^{n/2} + d_{\tilde{S}}(\alpha_{nm+1}(0), \alpha_{nm+1}(1)) - e^{n/2} \quad (\text{using the second inequality of } (*)) \\ &= d_{\tilde{S}}(\alpha_{nm+1}(0), \alpha_{nm+1}(1)) = |\alpha_{nm+1}|_{\tilde{S}} \end{aligned}$$

which is confirming the lemma. □

In the proof of Lemma 2.5.14, we claim that the terminal point of  $\widetilde{\varphi^{t_{nm+1}}(\gamma_1)}$  lies in  $\ell_{nm+2}$  without an explanation. We provide a proof for this claim in the following lemma.

**Lemma 2.5.15.** *Let  $\widetilde{\varphi^{t_{nm+1}}(\gamma_1)}$  be the path lift of  $\varphi^{t_{nm+1}}(\gamma_1)$  based at  $z_{nm+1}$ . Then the terminal point of  $\widetilde{\varphi^{t_{nm+1}}(\gamma_1)}$  lies in  $\ell_{nm+2}$*

*Proof.* We note that  $B_{nm+1} = B_1$ ,  $c_{nm+1} = c_1$  and  $\gamma_{nm+1} = \gamma_1$ . Let  $*$  be the image of  $y_{nm+1} \in \tilde{M}_{B_1}$  in  $M_{B_1}$  under the covering map. Let  $\omega$  be  $\gamma_1 \cdot c_1 \cdot \gamma_1^{-1}$ . Let  $\tilde{\omega}$  be the path lift of  $\omega$  in  $\tilde{M}_{B_1}$  based at  $y_{nm+1}$ . Draw a line that passes through  $\tilde{\omega}(1)$  parallel to a lift of the degeneracy slope  $\mathbf{s}_{c_1 B_1}$  in  $\tilde{M}_{B_1}$  until it meets the slice  $\tilde{B}_{nm+1} \times \{0\} \subset \tilde{S}$  at a point denoted by  $v$ . Let  $\tilde{u}$  be a path in  $\tilde{B}_{nm+1}$  connecting  $z_{nm+1}$  to  $x_{nm+2}$ , and let  $u$  be the image of  $\tilde{u}$  under the covering map. It follows that  $u$  and  $\gamma_1$  have the same endpoints.

We first show that  $[c_1]$  and  $[u^{-1} \cdot \varphi^{t_{nm+1}}(\gamma_1)]$  commute in  $\pi_1(B_1, \gamma_1(1))$ . Indeed, we note that  $\tilde{u} \cdot \tilde{c}_1 \cdot \tilde{u}^{-1}$  and  $[z_{nm+1}, y_{nm+1}] \cdot \tilde{\omega} \cdot [\tilde{\omega}(1), v]$  are paths connecting  $z_{nm+1}$  to  $v$ . Since  $\tilde{M}_{nm+1}$  is contractible, it follows that they are homotopic, and thus their images in  $M_{B_1}$  are homotopic as well. Since the homotopy class of the image of the path  $[z_{nm+1}, y_{nm+1}] \cdot \tilde{\omega} \cdot [\tilde{\omega}(1), v]$  in  $M_{B_1}$  is  $f^{-t_{nm+1}}[\omega]f^{t_{nm+1}}$  where  $f = [s_{c_1 B_1}] \in \pi_1(M_{B_1}, *)$ . It follows that  $[u \cdot c_1 \cdot u^{-1}] = f^{-t_{nm+1}}[\omega]f^{t_{nm+1}}$ . In  $\pi_1(M_{B_1}, *)$  we have that  $[\varphi^{t_{nm+1}}(\omega)] = f^{-t_{nm+1}}[\omega]f^{t_{nm+1}}$  (since  $\pi_1(M_{B_1}, *)$  is the semidirect product of  $\pi_1(B_1)$  and  $\langle f \rangle$ ). Hence,  $[u \cdot c_1 \cdot u^{-1}] = [\varphi^{t_{nm+1}}(\omega)]$  in  $\pi_1(M_{B_1})$ . It follows that  $\tilde{u} \cdot \tilde{c}_1 \cdot \tilde{u}^{-1}$  and  $\widetilde{\varphi^{t_{nm+1}}(\omega)}$  have the same endpoints, and thus they are homotopic in  $\tilde{B}_{nm+1}$  because  $\tilde{B}_{nm+1}$  is contractible. Thus, their images in  $B_1$  are homotopic. In other words,  $u \cdot c_1 \cdot u^{-1}$  and  $\varphi^{t_{nm+1}}(\gamma_1) \cdot c_1 \cdot \varphi^{-t_{nm+1}}(\gamma_1)$  are homotopic in  $B_1$ . It follows that  $[c_1]$  and  $[u^{-1} \cdot \varphi^{t_{nm+1}}(\gamma_1)]$  commute in  $\pi_1(B_1, \gamma_1(1))$ .

Since  $\pi_1(B_1, \gamma_1(1))$  is a free group, it follows that  $[c_1]$  and  $[u^{-1} \cdot \varphi^{t_{nm+1}}(\gamma_1)]$  are powers of a common element (the subgroup generated by  $[c_1]$  and  $[u^{-1} \cdot \varphi^{t_{nm+1}}(\gamma_1)]$  is an abelian, free subgroup of  $\pi_1(B_1, \gamma_1(1))$ , thus it is a cyclic subgroup). Since  $c_1$  is a simple closed curve and it is not null-homotopic, it follows that  $[c_1]$  is a primitive element (in the sense that there does not exist any  $h \in \pi_1(B_1, \gamma_1(1))$  such that  $[c_1] = h^k$  where  $|k| > 1$ ) (see Proposition 1.4 [FM12]). Thus,  $[u^{-1} \cdot \varphi^{t_{nm+1}}(\gamma_1)] = [c_1]^k$  for some integer  $k$ . It follows that

$\varphi^{tnm+1}(\gamma_1)$  is homotopic to  $u \cdot c_1^k$ . Since  $\tilde{u}(1) = x_{nm+2} \in \ell_{nm+2}$ , it follows that the terminal point of  $\widetilde{\varphi^{tnm+1}(\gamma_1)}$  lies in  $\ell_{nm+2}$ .  $\square$

**Lemma 2.5.16.** *Suppose that  $M_1$  is a hyperbolic block of  $N$ . Then  $e^{e^n}$  is dominated by  $d_{\tilde{S}}(z_1, \sigma_n(1))$ .*

*Proof.* Let  $F$  be the function given by Lemma 2.5.14. We recall that  $F(n) \sim e^{e^n}$ . Let  $n_1$  be the constant given by Lemma 2.5.14. For each  $n \geq n_1 + 1$ , let  $[z_1, \sigma_n(1)]$  be the geodesic in  $\tilde{S}$  connecting  $z_1$  to  $\sigma_n(1)$ . Let  $\mathbf{T}_S$  be the tree given by Definition 2.4.8. The subpath  $[z_j, z_{j+1}]$  (with  $j = 1, \dots, nm - 1$ ), the subpath  $[z_{nm}, \alpha_{nm}(1)] \cdot \tilde{c}_1^{k_0} \cdot [z_{nm}, \alpha_{nm}(1)]^{-1}$ , and the subpath  $[z_j, z_{j+1}]^{-1}$  (with  $j = 1, \dots, nm - 1$ ) of  $\sigma_n$  belong to pieces of  $\tilde{S}$ . These pieces correspond to vertices of  $\mathbf{T}_S$ . By our construction of  $\sigma_n$  and by Lemma 2.5.12, these vertices are distinct. It follows that the geodesic  $[z_1, \sigma_n(1)]$  must come through all these pieces. Thus,  $[z_1, \sigma_n(1)]$  must come through the piece  $\tilde{B}_{(n-1)m+1}$ , and  $[z_1, \sigma_n(1)]$  enters  $\tilde{B}_{(n-1)m+1}$  at  $\ell_{(n-1)m}$  and leaves  $\tilde{B}_{(n-1)m+1}$  at  $\ell_{(n-1)m+1}$ . Using the fact that  $\alpha_{(n-1)m+1}$  is a shortest path from  $\ell_{(n-1)m}$  to  $\ell_{(n-1)m+1}$ . It follows that  $|\alpha_{(n-1)m+1}|_{\tilde{S}} \leq d_{\tilde{S}}(z_1, \sigma_n(1))$ . As  $F(n) \sim e^{e^n}$ , it implies that  $F(n-1) \sim e^{e^{n-1}}$ . Using Lemma 2.5.14, we have  $F(n-1) \leq |\alpha_{(n-1)m+1}|_{\tilde{S}} \leq d_{\tilde{S}}(z_1, \sigma_n(1))$ . The lemma is verified.  $\square$

The proof of the following lemma is similar to the proof of Lemma 5.4 in Chapter 1.

**Lemma 2.5.17.** *The distance in  $\tilde{N}$  between the endpoints of  $\sigma_n$  is bounded above by a linear function of  $n$ .*

*Proof.* We recall that  $\tau_n$  is the concatenation of geodesics

$$[z_1, z_2], [z_2, z_3], \dots, [z_{nm-1}, z_{nm}], [z_{nm}, \alpha_{nm+1}(1)]$$

Note that in the Construction 2.5.10, we also produce points  $y_1, \dots, y_{nm+1}$  in  $\tilde{N}$ . Similarly, we also have points  $\bar{y}_{nm+1}, \dots, \bar{y}_1$  associating to  $\tau_n^{-1}$ . Our purpose is to show the distance in  $(\tilde{N}, d)$  between the endpoints of  $\sigma_n$  is bounded above by a linear function of  $n$ . By the

triangle inequality it suffices to produce an upper bound for the distance between successive points of the linear sequence

$$y_1, y_2, \dots, y_{nm+1}, \bar{y}_{nm+1}, \dots, \bar{y}_1$$

Let  $A$  is the constant given by Lemma 2.5.9. Let  $\bar{A}$  be the maximum of all possible numbers  $\max\{|\gamma_j| + A\overleftarrow{\lambda}_{j+1} + k_0|c_j| + t_1\overrightarrow{\lambda}_1\}$ . By Remark 2.5.11 and Lemma 2.5.9 we have  $d(y'_j, y_j) = (t_j/\xi_j - t_{j-1})\overleftarrow{\lambda}_j \leq A\overleftarrow{\lambda}_j$ . Using the triangle inequality, we have  $d(y_j, y_{j+1}) \leq d(y_j, y'_{j+1}) + d(y'_{j+1}, y_{j+1}) \leq |\gamma_j| + d(y'_{j+1}, y_{j+1}) \leq |\gamma_j| + A\overleftarrow{\lambda}_{j+1} \leq \bar{A}$  for all  $j \geq 0$ . Therefore  $d(y_1, y_{mn+1}) \leq \bar{A}mn$ . Similarly, we have  $d(\bar{y}_1, \bar{y}_{mn+1}) \leq \bar{A}mn$ . We note that two points  $y_{nm+1}$  and  $\bar{y}_{nm+1}$  belong to the same plane  $\tilde{T}_{nm+1}$  and  $d(y_{nm+1}, \bar{y}_{nm+1}) \leq k_0|c_1| \leq \bar{A}$ . Thus,  $d(y_1, \bar{y}_1) \leq d(y_1, y_{nm+1}) + d(y_{nm+1}, \bar{y}_{nm+1}) + d(\bar{y}_{nm+1}, \bar{y}_1) \leq 2\bar{A}mn + \bar{A}$ . Since  $d(z_1, y_1) = t_1\overrightarrow{\lambda}_1 \leq \bar{A}$  and  $d(\bar{z}_1, \bar{y}_1) = t_1\overrightarrow{\lambda}_1 \leq \bar{A}$ , it follows that  $d(\sigma_n(0), \sigma_n(1)) = d(z_1, \bar{z}_1) \leq d(z_1, y_1) + d(y_1, \bar{y}_1) + d(\bar{y}_1, \bar{z}_1) \leq 2\bar{A}nm + 3\bar{A}$ .  $\square$

*Proof of Proposition 2.5.8.* If there is a closed curve  $\gamma$  such that it satisfies the hypothesis of Lemma 2.5.9 and passing through a hyperbolic block, then Proposition 2.5.8 is confirmed by a combination of the previous lemmas in this section. What remains to be shown is that the existence of the curve  $\gamma$ .

Since the spirality of  $S$  is non-trivial, we can choose a closed curve  $\alpha$  in  $S$  with nonempty intersection with  $\mathcal{T}_g$  such that  $w(\alpha) > 1$ . If the curve  $\alpha$  already passes through a geometrically infinite piece, then we let  $\gamma = \alpha$ . If not, we need to extend the curve  $\alpha$  to a new closed curve  $\gamma$  so that  $w(\gamma) = w(\alpha)$  and  $\gamma$  has nonempty intersection with a curve in  $\mathcal{T}_g$  that is a boundary component of a piece of  $S$ , and this piece is mapped into a hyperbolic block of  $N$ . We describe below how we find such a curve  $\gamma$ .

The collection  $\mathcal{T}_g$  subdivides  $\alpha$  into a concatenation  $\alpha_1 \cdots \alpha_n$  such that each  $\alpha_i$  belongs to a piece  $B_i$  of  $S$ , starting on a circle  $c_i \in \mathcal{T}_g$  and ending on the circle  $c_{i+1}$ . Note that by our assumption above, each piece  $B_i$  is horizontal surface. We recall that  $\Gamma(\mathcal{T}_g)$  is the graph dual

to the collection  $\mathcal{T}_g$  on  $S$ . Let  $v_i$  be the vertex in  $\Gamma(\mathcal{T}_g)$  associated to the piece  $B_i$ . The closed curve  $\alpha$  determines the closed cycle  $e_1 \cdots e_n$  in  $\Gamma(\mathcal{T}_g)$  where the initial vertex and terminal vertex of the edge  $e_i$  are  $v_i$  and  $v_{i+1}$  respectively (with a convention that  $v_{n+1} = v_1$ ).

Since  $S$  contains a geometrically infinite piece, let  $u$  be the vertex in  $\Gamma(\mathcal{T}_g)$  associated to this piece. It follows that  $u \neq v_i$  for any  $i = 1, \dots, n$ . There exists  $j \in \{1, \dots, n\}$  such that the following holds: there exists a  $\beta$  in  $\Gamma(\mathcal{T}_g)$  with no self intersection connecting  $v_j$  to  $u$  such that the other vertices  $v_i$  with  $i \neq j$  does not appear on  $\beta$ . Without loss generality, we assume  $j = 1$ . Note that  $S$  is a clean almost fiber surface, so every piece of  $S$  is neither an annulus or a disk. We thus choose a path  $\gamma'$  connecting  $\alpha_1(0)$  to  $\alpha_1(1)$  with non-empty intersection with  $\mathcal{T}_g$  such that it can not be homotoped out of the geometrically finite piece, and the corresponding path of  $\gamma' \subset S$  in  $\Gamma(\mathcal{T}_g)$  is the back-tracking path  $\beta \cdot \beta^{-1}$ . Let  $\gamma$  be the concatenation of  $\gamma' \cdot \alpha_2 \cdots \alpha_n$ . It follows that  $w(\gamma) = w(\alpha)$ . Since  $w(\alpha) > 1$ , we obtain  $w(\gamma) > 1$ . □

## 2.6 Distortion of surfaces in non-geometric 3-manifolds

In Section 2.4, we show that the distortion of a clean surface subgroup in a non-geometric 3-manifold group can be determined by looking at the distortion of the clean almost fiber part. We recall that the almost fiber part contains only horizontal and geometrically infinite pieces. The distortion of properly immersed  $\pi_1$ -injective horizontal surfaces in graph manifolds is computed in Chapter 1. In the setting of mixed manifold, the distortion of a clean almost fiber part is addressed in Section 2.5. In this section, we compute the distortion of arbitrary clean surface in a non-geometric 3-manifold by putting the previous results together.

**Lemma 2.6.1.** *Let  $S$  be a clean almost fiber surface in a graph manifold  $N$ . Let  $\Delta$  be the distortion of  $\pi_1(S)$  in  $\pi_1(N)$ . If  $S$  contains only one horizontal piece then  $\Delta$  is linear. If  $S$  contains at least two horizontal pieces, then  $\Delta$  is quadratic if the spirality of  $S$  is trivial, otherwise it is exponential.*

*Proof.* The fundamental group of a Seifert fibered block in  $\pi_1(N)$  is undistorted. If  $S$  contains only one horizontal piece then  $\Delta$  is linear by Remark 2.3.7 and Proposition 2.2.1. We now consider the case  $S$  has at least two horizontal pieces. We remark that the main theorem in Chapter 1 states for properly immersed  $\pi_1$ -injective, horizontal surfaces. However, the proof of the main theorem in Chapter 1 still hold for clean almost fiber surfaces.  $\square$

*Proof of Theorem 2.1.4.* The proof is a combination of Lemma 2.6.1, Theorem 2.4.1, and (1) in Remark 2.3.12.  $\square$

*Proof of Theorem 2.1.2.* If  $\Phi(S)$  is empty then the distortion of  $\pi_1(S)$  in  $\pi_1(N)$  is linear by Corollary 2.4.3. We now assume that  $\Phi(S)$  is non-empty. By Theorem 2.4.1, it is suffice to compute the distortion of each component of the almost fiber part  $\Phi(S)$  in  $N$ .

Let  $N'$  be a submanifold of  $N$  such that the restriction  $g|_{S'}: S' \looparrowright N'$  is a clean almost fiber surface. Note that  $\pi_1(N')$  is undistorted in  $\pi_1(N)$ , thus the distortion of  $\pi_1(S')$  in  $\pi_1(N)$  is equivalent to the distortion of  $\pi_1(S')$  in  $\pi_1(N')$ . To compute the distortion of  $\pi_1(S')$  in  $\pi_1(N')$ , we note that the distortions of clean almost fiber surfaces in mixed manifolds, graph manifolds, Seifert fibered spaces and hyperbolic spaces are addressed in Theorem 2.1.5, Theorem 2.1.4 and Remark 2.3.7 respectively. The proof of the theorem follows easily by combining these results together with (1) in Remark 2.3.12.  $\square$

# Chapter 3

## Quasi-isometries of pairs: surfaces in graph manifolds

### 3.1 Introduction

A finitely generated group  $G$  can be considered as a metric space when we equip  $G$  with the word metric from a finite generating set. With different finite generating sets on  $G$  we have different metrics on  $G$ , however such metric spaces are unique up to *quasi-isometric* equivalence. The notion of quasi-isometry that ignores small scale details is especially significant in geometric group theory following the work of Gromov. Two quasi-isometries of  $G$  are called equivalent if they are within finite distance from each other. The group of quasi-isometries of  $G$ , denoted by  $QI(G)$  is the set of equivalence classes of quasi-isometries  $G \rightarrow G$  with the canonical operation (i.e, composition of maps). We note that if two finitely generated groups are quasi-isometric then their corresponding quasi-isometry groups are isomorphic.

Quasi-isometric classification of graph manifolds has been studied by Kapovich-Leeb [KL98] and a complete quasi-isometric classification for fundamental groups of graph manifolds is given by Behrstock-Neumann in [BN08]. In particular, Behrstock-Neumann proved that the fundamental groups of all closed graph manifolds are quasi-isometric. Thus, there

is exactly one quasi-isometry group of fundamental group of closed graph manifolds. When  $N$  is a closed graph manifold, the construction of quasi-isometries of Behrstock-Neumann is very flexible and produces many quasi-isometric classes in  $QI(\pi_1(N))$ .

A subgroup  $H \leq G$  is called *separable* if for any  $g \in G - H$  there exists a finite index subgroup  $K \leq G$  such that  $H \leq K$  and  $g \notin K$ . A horizontal surface  $S \looparrowright N$  in a graph manifold  $N$  is called *separable* if  $\pi_1(S)$  is a separable subgroup in  $\pi_1(N)$ . In Chapter 1, we show that the distortion of  $\pi_1(S)$  in  $\pi_1(N)$  is quadratically distorted whenever the surface is separable and is exponentially distorted otherwise. Therefore, there does not exist any quasi-isometry of fundamental groups of closed graph manifolds mapping a separable, horizontal surface to a non-separable, horizontal surface.

The purpose of this paper is trying to understand whether such quasi-isometries exist which map any separable (resp. non-separable) surface to another separable (resp. non-separable) surface.

If the two surfaces are both separable or both non-separable, then the subgroup distortion is not an useful quasi-isometric invariant to look at for the purpose above. Beside subgroup distortion, we remark that there are several other key quasi-isometric invariants of a pair  $(G, H)$  in literature such as upper, lower relative divergence [Tra15], and  $k$ -volume distortion ( $k \geq 1$ ) [Ben11], [Ger96]. However, again the  $k$ -volume distortion is not an useful quasi-isometric invariant for our purpose above. We show that  $k$ -volume distortion of the surface subgroup in the 3-manifold group is always trivial if  $k \geq 3$ , linear when  $k = 2$ , and quadratic (resp. exponential) when  $k = 1$  and the surface is separable (resp. non-separable). Relative divergence which is introduced by Tran [Tra15] is quite technical and difficult to compute in general. Recent work of Tran [Tra17] allows us to show that the upper (lower) relative divergence of a separable, horizontal surface in a graph manifold is quadratic (linear) (see Appendix), however the author does not know the upper relative divergence and lower relative divergence in the non-separable case.

So far, none of the invariants discussed above can distinguish between two separable

surfaces or two non-separable surfaces. The following questions are natural to ask.

**Question 3.1.1.** Given a closed graph manifold  $N$ . Are all pairs  $(\pi_1(N), \pi_1(S))$  and  $(\pi_1(N), \pi_1(S'))$  with  $S$  and  $S'$  non-separable in  $N$ , quasi-isometric?

**Question 3.1.2.** Given a closed graph manifold  $N$ . Are all pairs  $(\pi_1(N), \pi_1(S))$  and  $(\pi_1(N), \pi_1(S'))$  with  $S$  and  $S'$  separable in  $N$ , quasi-isometric?

In the questions above, two pairs  $(G, H)$  and  $(G', H')$  with  $H \leq G$  and  $H' \leq G'$  are *quasi-isometric* if there is a quasi-isometry  $G \rightarrow G'$  mapping  $H$  to  $H'$  within a finite Hausdorff distance.

In this paper we show the answer to the Question 3.1.1 is no. We give examples of non-separable surfaces where such quasi-isometries never exist. The main theorem of this paper is the following

**Theorem 3.1.3.** *There exists a closed simple graph manifold  $N$  and infinitely many non-separable, horizontal surface  $S_n \looparrowright N$  such that none of the pairs  $(\pi_1(N), \pi_1(S_n))$  and  $(\pi_1(N), \pi_1(S_m))$  are quasi-isometric when  $n \neq m$*

No example is currently known for separable, horizontal surfaces  $S \looparrowright N$  and  $S' \looparrowright N$  such that  $(\pi_1(N), \pi_1(S))$  and  $(\pi_1(N), \pi_1(S'))$  are not quasi-isometric. Thus, we propose the following conjecture.

**Conjecture 3.1.4.** *Let  $N$  and  $M$  be two closed graph manifolds. Let  $S \looparrowright N$  and  $S' \looparrowright M$  be two separable, horizontal surfaces. Then there is a quasi-isometry from  $\pi_1(N)$  to  $\pi_1(M)$  mapping  $\pi_1(S)$  to  $\pi_1(S')$  in a finite Hausdorff distance.*

Although this paper deals only with graph manifolds, it is interesting to work on other classes of 3-manifolds. We note that if  $\Gamma \leq \text{Isom}(\mathbb{H}^n)$  ( $n \geq 3$ ) is a nonuniform lattice and  $\Gamma$  is torsion-free then the quotient space  $N = \mathbb{H}^n/\Gamma$  is a hyperbolic manifold of finite volume. In the setting of non-uniform lattices in  $\text{Isom}(\mathbb{H}^n)$  ( $n \geq 3$ ), quasi-isometry of pairs can be interpreted via algebraic properties of groups (see Theorem 3.1.5) thank to Schwartz Rigidity Theorem.

**Theorem 3.1.5.** *Let  $\Gamma$  and  $\Gamma'$  be two non-uniform lattices of  $\text{Isom}(\mathbb{H}^n)$  with  $n \geq 3$ . Let  $H$  and  $H'$  be two finitely generated subgroups of  $\Gamma$  and  $\Gamma'$  respectively. Then  $(\Gamma, H)$  and  $(\Gamma', H')$  are quasi-isometric if and only if there exists  $g \in \text{Isom}(\mathbb{H}^n)$  such that  $gHg^{-1}$  and  $H'$  are commensurable as well as  $g\Gamma g^{-1}$  and  $\Gamma'$  are commensurable.*

## 3.2 Quasi-isometry of the pairs of spaces

In this section, we review some notions in geometric group theory.

Let  $(X, d)$  be a metric space, and  $\gamma$  a path in  $X$ . We denote the length of  $\gamma$  by  $|\gamma|$ . If  $A$  and  $B$  are subsets of  $X$ , the *Hausdorff distance* between  $A$  and  $B$  is

$$d_{\mathcal{H}}(A, B) = \inf \{ r \mid A \subseteq \mathcal{N}_r(B) \text{ and } B \subseteq \mathcal{N}_r(A) \}$$

where  $\mathcal{N}_r(C)$  denotes the  $r$ -neighborhood of a subset  $C$ .

**Definition 3.2.1.** Let  $X$  and  $Y$  be metric spaces. Let  $A$  be a subspace of  $X$  and  $B$  a subspace of  $Y$ . Two pairs of spaces  $(X, A)$  and  $(Y, B)$  is called *quasi-isometric* if there exists an  $(L, C)$ -quasi-isometry  $f: X \rightarrow Y$  such that  $f(A) \subseteq B$  and  $B \subseteq \mathcal{N}_C(f(A))$ . We call the map  $f$  an  $(L, C)$ -*quasi-isometry of pairs*. We denote  $(X, A) \sim (Y, B)$  if  $(X, A)$  and  $(Y, B)$  are quasi-isometric, and  $(X, A) \approx (Y, B)$  otherwise.

**Definition 3.2.2.** Let  $G$  and  $G'$  be finitely generated groups with finite generating sets  $\mathcal{S}$  and  $\mathcal{S}'$  respectively. Let  $\Gamma(G, \mathcal{S})$  and  $\Gamma(G', \mathcal{S}')$  be the Cayley graphs of  $(G, \mathcal{S})$  and  $(G', \mathcal{S}')$  respectively. Let  $H$  be a subgroup of  $G$  and  $H'$  a subgroup of  $G'$ . We say  $(G, H)$  and  $(G', H')$  are quasi-isometric if the pairs of spaces  $(\Gamma(G, \mathcal{S}), H)$  and  $(\Gamma(G', \mathcal{S}'), H')$  are quasi-isometric.

**Remark 3.2.3.** 1. We note that  $\sim$  is an equivalent relation, and the relation  $(G, H) \sim (G', H')$  is independent of choices of generating sets for the groups.

2. If there is a quasi-isometry  $f: X \rightarrow Y$  such that  $d_{\mathcal{H}}(f(A), B)$  is finite then  $(X, A)$  and  $(Y, B)$  are quasi-isometric.

- Example 3.2.4.** 1. Let  $H \leq G_1$  be finitely generated subgroups of a finitely generated group  $G$ . Suppose that  $G_1$  is a finite index subgroup in  $G$ . Then  $(G, H) \sim (G_1, H)$ .
2.  $(G, H) \sim (G, G)$  if and only if  $H$  is a finite index subgroup of  $G$ .
3. Let  $F_n$  be the free group on  $n$  generators with  $n \geq 2$ . It is well-known that there are two isomorphic subgroups  $H$  and  $K$  of  $F_n$  such that  $H$  is a finite index subgroup of  $F_n$  and  $K$  is an infinite index subgroup of  $F_n$ . It follows from (2) that  $(F_n, H) \approx (F_n, K)$ .
4. Let  $M_1$  and  $M_2$  be Seifert fibered spaces with the base surfaces have negative Euler characteristic and nonempty boundary. Let  $S_1$  and  $S_2$  be two properly immersed  $\pi_1$ -injective horizontal surfaces in  $M_1$  and  $M_2$  respectively. The immersion  $S_j \looparrowright M_j$  lifts to an embedding  $S_j \rightarrow S_j \times S^1$  (which sends  $x \in S_j$  to  $(x, (1, 0)) \in S_j \times S^1$ ) in a finite cover  $S_j \times S^1$  of  $M_j$  (see Lemma 2.1 [RW98]). Since  $\pi_1(S_j)$  is free, there exists a quasi-isometry  $f: \pi_1(S_1) \rightarrow \pi_1(S_2)$ . Let  $\varphi: \pi_1(S_1) \times \mathbb{Z} \rightarrow \pi_1(S_2) \times \mathbb{Z}$  be the map given by  $\varphi(x, n) = (f(x), n)$ . It follows that  $\varphi$  is a quasi-isometry mapping  $\pi_1(S_1)$  to  $\pi_1(S_2)$ . Thus  $(\pi_1(S_1 \times S^1), \pi_1(S_1)) \sim (\pi_1(S_2 \times S^1), \pi_1(S_2))$ . Using (1) in Example 3.2.4, we have  $(\pi_1(M_1), \pi_1(S_1)) \sim (\pi_1(M_2), \pi_1(S_2))$ .

**Definition 3.2.5** (Commensurable). Let  $G$  be a group. Two subgroups  $H$  and  $K$  of  $G$  are called *commensurable* if  $H \cap K$  is a finite index subgroup of both  $H$  and  $K$ .

We use the following lemma in the proof of Theorem 3.1.5.

**Lemma 3.2.6** (Corollary 2.4 [MSW11]). *Two subgroups  $H$  and  $K$  are commensurable in a finitely generated group  $G$  if and only if  $H$  is within a finite Hausdorff distance with  $K$ .*

*Proof of Theorem 3.1.5.* We are going to prove sufficiency. Let equip  $\Gamma$  and  $\Gamma'$  with word metrics. Let  $f: \Gamma \rightarrow \Gamma'$  be a quasi-isometry such that  $f(H)$  is within a finite Hausdorff distance with  $H'$  with respect to the word metric on  $\Gamma'$ . By Schwartz Rigidity Theorem [Sch95] (see also, for example, Theorem 24.1 [DtK18]), there exists  $g \in \text{Isom}(\mathbb{H}^n)$  such that the following holds:

1.  $g\Gamma g^{-1}$  and  $\Gamma'$  are commensurable.
2. Let  $G$  be the subgroup of  $\text{Isom}(\mathbb{H}^n)$  generated by two subgroups  $g\Gamma g^{-1}$  and  $\Gamma'$ . We note that  $G$  is a finitely generated subgroup. We equip  $G$  with a word metric. For each  $\gamma \in \Gamma$ , choose  $y_\gamma \in \Gamma'$  which is nearest to  $g\gamma g^{-1}$  with respect to the word metric on  $G$ . Then the map  $q_g: \Gamma \rightarrow \Gamma'$  which sends  $\gamma$  to  $y_\gamma$  is a quasi-isometry and  $q_g$  is within finite distance from  $f$ .

We will need to show  $gHg^{-1}$  and  $H'$  are commensurable. Let  $d_{\mathcal{H}}$  denote for the Hausdorff distance of any two subsets of  $G$  with respect to the given word metric on  $G$ . By the definition of  $q_g$  we have  $d_{\mathcal{H}}(gHg^{-1}, q_g(H)) < \infty$  and  $d_{\mathcal{H}}(q_g(H), f(H)) < \infty$ . By the assumption of  $f$  we have  $d_{\mathcal{H}}(f(H), H') < \infty$ . We use the triangle inequality to get that

$$d_{\mathcal{H}}(gHg^{-1}, H') \leq d_{\mathcal{H}}(gHg^{-1}, q_g(H)) + d_{\mathcal{H}}(q_g(H), f(H)) + d_{\mathcal{H}}(f(H), H') < \infty.$$

Thus,  $gHg^{-1}$  and  $H'$  are commensurable by Lemma 3.2.6.

We now are going to prove necessity. Suppose that there exists  $g \in \text{Isom}(\mathbb{H}^n)$  such that  $gHg^{-1}$  and  $H'$  are commensurable as well as  $g\Gamma g^{-1}$  and  $\Gamma'$  are commensurable. Let  $G$  be the subgroup of  $\text{Isom}(\mathbb{H}^n)$  generated by two subgroups  $g\Gamma g^{-1}$  and  $\Gamma'$ . We equip  $G$  with a word metric  $d$ , and with respect to this metric we denote  $d_{\mathcal{H}}$  the Hausdorff distance of any two subsets of  $G$ . Since  $gHg^{-1}$  and  $H'$  are commensurable as well as  $g\Gamma g^{-1}$  and  $\Gamma'$  are commensurable, it follows that there is  $R > 0$  such that  $d_{\mathcal{H}}(gHg^{-1}, H') \leq R$  and  $d_{\mathcal{H}}(\Gamma', g\Gamma g^{-1}) \leq R$ . For each  $\gamma \in \Gamma$ , choose an element  $q_g(\gamma)$  in  $\Gamma'$  such that  $d(q_g(\gamma), g\gamma g^{-1}) \leq R$ . We thus define the map  $q_g: \Gamma \rightarrow \Gamma'$ . Since the map  $\Gamma \rightarrow g\Gamma g^{-1}$  which sends  $\gamma$  to  $g\gamma g^{-1}$  is a quasi-isometry and  $q_g$  is within finite distance from the map  $\Gamma \rightarrow g\Gamma g^{-1}$ , it follows that  $q_g$  is a quasi-isometry. From the definition of  $q_g$ , it is obvious that  $d_{\mathcal{H}}(q_g(H), gHg^{-1}) \leq R$ . We use the facts  $d_{\mathcal{H}}(q_g(H), gHg^{-1}) \leq R$  and  $d_{\mathcal{H}}(gHg^{-1}, H') \leq R$  to get that

$$d_{\mathcal{H}}(q_g(H), H') \leq d_{\mathcal{H}}(q_g(H), gHg^{-1}) + d_{\mathcal{H}}(gHg^{-1}, H') \leq 2R$$

Thus  $(\Gamma, H)$  and  $(\Gamma, H')$  are quasi-isometric via the map  $q_g$ .  $\square$

We use the following lemma in the proof of Theorem 3.1.3.

**Lemma 3.2.7.** *Let  $G$  and  $G'$  be finitely generated groups with finite generating sets  $\mathcal{S}$  and  $\mathcal{S}'$  respectively. Let  $H$  and  $H'$  be finitely generated subgroups of  $G$  and  $G'$  with finite generating sets  $\mathcal{A}$  and  $\mathcal{A}'$  respectively such that  $\mathcal{A} \subseteq \mathcal{S}$  and  $\mathcal{A}' \subseteq \mathcal{S}'$ . Let  $\varphi: (\Gamma(G, \mathcal{S}), H) \rightarrow (\Gamma(G', \mathcal{S}'), H')$  be an  $(L, C)$ -quasi-isometry of pairs. Then there exists a constant  $L'$  such that*

$$\frac{|h|_{\mathcal{A}}}{L'} - L' \leq |\varphi(h)|_{\mathcal{A}'} \leq L'|h|_{\mathcal{A}} + L'$$

for all  $h \in H$ .

*Proof.* Let  $e$  and  $e'$  be the identity elements in the groups  $G$  and  $G'$ . For any  $h \in H$ , let  $\alpha$  be a geodesic in the Cayley graph  $\Gamma(H', \mathcal{A}')$  connecting  $\varphi(e)$  to  $\varphi(h)$ . We denote  $\varphi(e) = y_0, y_1, \dots, y_m = \varphi(h)$  be the sequence of vertices belong to  $\alpha$ . Since  $H' \subset N_C(\varphi(H))$ , there exists  $x_i \in H$  such that  $d_{\mathcal{S}'}(\varphi(x_i), y_i) \leq C$  with  $x_0 = e$  and  $x_m = h$ . Moreover, we have

$$d_{\mathcal{S}}(x_i, x_{i+1}) \leq L d_{\mathcal{S}'}(\varphi(x_i), \varphi(x_{i+1})) + C \leq L + C.$$

Since  $G$  is locally finite, it follows that there exists a constant  $R$  depending on  $L$  and  $C$  such that  $d_{\mathcal{A}}(x_i, x_{i+1}) \leq R$ . It is obvious that  $|h|_{\mathcal{A}} = d_{\mathcal{A}}(e, h) \leq mR$ , thus  $|h|_{\mathcal{A}} = d_{\mathcal{A}}(e, h) \leq R d_{\mathcal{A}'}(\varphi(e), \varphi(h)) \leq R|\varphi(e)|_{\mathcal{A}'} + R|\varphi(h)|_{\mathcal{A}'}$ . Let  $\bar{\varphi}$  be a quasi-inverse of  $\varphi$ , by a similar argument it is not hard to see that constants  $L'$  and  $C'$  exist.  $\square$

It is well known that a group acting properly, cocompactly, and isometrically on a geodesic space is quasi-isometric to the space. The following corollary of this fact allows us to show two pairs of (group, subgroup) are quasi-isometric using the geometric properties of spaces in place of words metrics.

**Corollary 3.2.8.** *Let  $X_i$  and  $Y_i$  be compact geodesic spaces, and let  $g: (Y_i, y_i) \rightarrow (X_i, x_i)$  be  $\pi_1$ -injective with  $i = 1, 2$ . We lift the metrics on  $X_i$  and  $Y_i$  to geodesic metrics on the*

universal covers  $\tilde{X}_i$  and  $\tilde{Y}_i$  respectively. Let  $G_i = \pi_1(X_i, x_i)$  and  $H_i = g_*(\pi_1(Y_i, y_i))$ . Then  $(\tilde{X}_1, \tilde{Y}_1)$  and  $(\tilde{X}_2, \tilde{Y}_2)$  are quasi-isometric if and only if  $(G_1, H_1)$  and  $(G_2, H_2)$  are quasi-isometric.

### 3.3 Graph manifolds and horizontal surfaces

In this section, we give some lemmas which will be used in the proof of Theorem 3.1.3 in Section 3.5.

In the following, we use the notation  $[\alpha] \wedge [\beta]$  to denote the algebraic intersection number of two oriented closed curves  $\alpha$  and  $\beta$  in a torus  $T$  with respect to some chosen orientation on  $T$ .

Let  $g: S \looparrowright N$  be a horizontal surface in a simple graph manifold  $N$  given by Definition 1.4.10. We have the following lemma that give us an alternative way to compute slopes.

**Lemma 3.3.1.** *For each oriented edge  $e$  in  $O(\Omega_S)$ . Let  $\overleftarrow{B}$  and  $\overrightarrow{B}$  be the components in  $S - g^{-1}(\mathcal{T})$  corresponding to the initial and terminal vertices of  $e$ . These components  $\overleftarrow{B}$  and  $\overrightarrow{B}$  are mapped by  $g$  into Seifert blocks  $\overleftarrow{M}$  and  $\overrightarrow{M}$  respectively. Let  $c$  be the circle in  $g^{-1}(\mathcal{T})$  corresponding to the edge  $e$  obtained by gluing a boundary circle  $\overleftarrow{c}$  of  $\overleftarrow{B}$  to a boundary circle  $\overrightarrow{c}$  of  $\overrightarrow{B}$ . The image  $g(c)$  in  $N$  lies in a JSJ torus  $T$  obtained by gluing a boundary torus  $\overleftarrow{T}$  of  $\overleftarrow{M}$  to a boundary torus  $\overrightarrow{T}$  of  $\overrightarrow{M}$ . Let  $\overleftarrow{\beta}$  and  $\overrightarrow{\beta}$  be fibers of  $\overleftarrow{M}$  and  $\overrightarrow{M}$  in the torus  $T$ . Let  $\overleftarrow{\alpha}$  and  $\overrightarrow{\alpha}$  be oriented simple closed curves in  $\overleftarrow{T}$  and  $\overrightarrow{T}$  respectively such that  $|\overleftarrow{\alpha} \wedge \overleftarrow{\beta}| = 1$  and  $|\overrightarrow{\alpha} \wedge \overrightarrow{\beta}| = 1$ . If  $[g(c)] = m[\overleftarrow{\alpha}] + n[\overleftarrow{\beta}]$  and  $[g(c)] = m'[\overrightarrow{\alpha}] + n'[\overrightarrow{\beta}]$  for some integers  $m, n, m'$  and  $n'$ . Then  $\mathbf{sl}(e) = |m/m'|$ .*

*Proof.* Let  $a$  and  $b$  be integers such that  $[g(c)] = a[\overleftarrow{\beta}] + b[\overrightarrow{\beta}]$ , By the definition of slope, we have  $\mathbf{sl}(e) = |b/a|$ . We use the distributive law and the scalar multiplication law of algebraic intersection together with the facts  $[\overleftarrow{\beta}] \wedge [\overleftarrow{\beta}] = 0$ ,  $|\overleftarrow{\alpha} \wedge [\overleftarrow{\beta}]| = 1$  and  $|\overleftarrow{\beta}] \wedge [\overrightarrow{\beta}]| = 1$  to

get that

$$\left| [g(c)] \wedge [\overleftarrow{\beta}] \right| = \left| m[\overleftarrow{\alpha}] \wedge [\overleftarrow{\beta}] + n[\overleftarrow{\beta}] \wedge [\overleftarrow{\beta}] \right| = |m|$$

and

$$\left| [g(c)] \wedge [\overleftarrow{\beta}] \right| = \left| a[\overleftarrow{\beta}] \wedge [\overleftarrow{\beta}] + b[\overrightarrow{\beta}] \wedge [\overleftarrow{\beta}] \right| = |b|$$

Thus,  $|m| = |b|$ .

Similarly, we get that

$$\left| [g(c)] \wedge [\overrightarrow{\beta}] \right| = \left| m'[\overrightarrow{\alpha}] \wedge [\overrightarrow{\beta}] + n'[\overrightarrow{\beta}] \wedge [\overrightarrow{\beta}] \right| = |m'|$$

and

$$\left| [g(c)] \wedge [\overrightarrow{\beta}] \right| = \left| a[\overleftarrow{\beta}] \wedge [\overrightarrow{\beta}] + b[\overrightarrow{\beta}] \wedge [\overrightarrow{\beta}] \right| = |a|$$

Thus,  $|m'| = |a|$ . It follows that  $|b/a| = |m/m'|$ . Therefore  $\mathbf{sl}(e) = |m/m'|$ .  $\square$

We use the following lemma in the construction of surfaces in Lemma 3.4.1.

**Lemma 3.3.2** (Lemma 2.2 in [RW98]). *Let  $F$  be a surface with non-empty boundary, positive genus and  $\chi(F) < 0$ . Let  $M$  be the trivial Seifert fibered space  $F \times S^1$ . We fix orientations of the surface  $F$  and the fiber  $S^1$  of  $M$ . Let  $\{\alpha_i \mid i = 1, 2, \dots, t\}$  be the collection of oriented boundary curves of the surface  $F$ . Let  $T_i = T(\alpha_i, \beta_i)$  be the boundary torus of  $M = F \times S^1$  where  $\beta_i$  is a oriented fiber  $S^1$  corresponding to the second factor of  $M$  with  $i = 1, 2, \dots, n$ . Suppose that  $\{c_{ij} \mid j = 1, 2\}$  is a family of oriented simple closed curves on  $T_i$  and*

$$[c_{ij}] = u_{ij}[\alpha_i] + v_{ij}[\beta_i] \quad \text{in } H_1(T_i)$$

for some integers  $u_{ij}$  and  $v_{ij}$  with  $u_{ij} > 0$ .

Then the union of family  $\{c_{ij} \mid j = 1, 2\}$  is a boundary of a connected immersed orientable horizontal surface  $S$  in  $M$  if the following holds

1.  $\sum_{i=1}^n \sum_{j=1}^2 v_{ij} = 0$

2. There exists  $u > 0$  such that for all  $i$  we have  $u_{i1} + u_{i2} = u$ .

3.  $u\chi(F)$  is even.

**Remark 3.3.3.** Let  $S \looparrowright M$  be the horizontal surface given by Lemma 3.3.2. By the construction, we note that the number of boundary components of  $S$  is  $2t$ . We can compute the genus  $x$  of  $S$  as the follows. The composition of  $S \looparrowright M$  with the projection of  $M$  to  $F$  yields a finite covering map  $S \rightarrow F$  with degree  $u$ . Hence,  $\chi(S) = u\chi(F)$ . It follows that  $2 - 2x - 2t = u\chi(F)$ . Thus,  $x = (2 - 2t - u\chi(F))/2$ .

Let  $\overleftarrow{\alpha}, \overleftarrow{\beta}, \overrightarrow{\alpha}$  and  $\overrightarrow{\beta}$  be the copies of the circle  $S^1$ . Let  $\overleftarrow{T} = \overleftarrow{\alpha} \times \overleftarrow{\beta}$  and  $\overrightarrow{T} = \overrightarrow{\alpha} \times \overrightarrow{\beta}$ . Let  $J = \begin{pmatrix} p & q \\ r & s \end{pmatrix}$  be the 2 by 2 matrix such that  $p, q, r, s \in \mathbb{Z}$ ,  $q \neq 0$  and  $ps - qr = -1$ . With respect to the matrix  $J$ , the basis  $\{[\overleftarrow{\alpha}], [\overleftarrow{\beta}]\}$  in  $H_1(\overleftarrow{T})$ , and the basis  $\{[\overrightarrow{\alpha}], [\overrightarrow{\beta}]\}$  in  $H_1(\overrightarrow{T})$ , there is a homeomorphism  $h: \overleftarrow{T} \rightarrow \overrightarrow{T}$  such that  $h_*: H_1(\overleftarrow{T}) \rightarrow H_1(\overrightarrow{T})$  has the matrix  $J$  in the sense that

$$h_*\left(a[\overleftarrow{\alpha}] + b[\overleftarrow{\beta}]\right) = \left([\overrightarrow{\alpha}], [\overrightarrow{\beta}]\right) \begin{pmatrix} p & q \\ r & s \end{pmatrix} \begin{pmatrix} a \\ b \end{pmatrix}$$

In the rest of this paper, when we say we glue the torus  $\overleftarrow{T}$  to the torus  $\overrightarrow{T}$  via matrix  $J$ , we mean that the gluing map is the homeomorphism  $h$ .

## 3.4 Constructing horizontal surfaces

In this section, we will construct a closed simple graph manifold  $N$  and a collection of horizontal surfaces  $\{S_n \looparrowright N\}$  such that when we pass to a specific subsequence then this subsequence satisfies the conclusion of Theorem 3.1.3. We also recall some facts from Chapter 1 that will be used in Section 3.5.

**Lemma 3.4.1.** *There exists a closed simple graph manifold  $N$  such that for any  $n \in \mathbb{N}$ , there exists a non-separable, horizontal surface  $g_n: S_n \looparrowright N$  with the following properties.*

1. The governor of  $g_n: S_n \looparrowright N$  is  $\epsilon_n = 2n + 1$

2. Let  $\mathcal{T}$  be the union of the JSJ tori of  $N$ . There exists a simple closed curve  $\gamma_n$  in  $S_n$  such that the geometric intersection number of  $\gamma_n$  and  $g_n^{-1}(\mathcal{T})$  is 2 and  $w(\gamma_n) = (2n + 1)^2$ .

*Proof.* We first construct a simple graph manifold  $N'$  with non-empty boundary, and a non-separable horizontal surface  $B_n \looparrowright N'$  (for each  $n$ ) satisfying the conclusion of the lemma (we refer the reader to Figure 3.1 for an illustration.), and then obtain a closed simple graph manifold  $N$  and a closed surface  $S_n$  by doubling  $N'$  and  $B_n$  along their boundaries respectively. The construction here is inspired from Example 2.6 in [RW98].

Let  $\overleftarrow{F}$  be the once punctured torus with the boundary circle denoted by  $\overleftarrow{\alpha}$ . Let  $\overleftarrow{\beta}$  be the fiber factor of the trivial Seifert fibered space  $\overleftarrow{F} \times S^1$ . We denote the boundary torus of  $\overleftarrow{F} \times S^1$  by  $\overleftarrow{T}_1$ . We fix orientations of  $\overleftarrow{F}$  and  $\overleftarrow{\beta}$ . Let  $\overrightarrow{F}$  be a twice punctured torus with two boundary circles denoted by  $\overrightarrow{\alpha}$  and  $\overrightarrow{\alpha}'$ . Let  $\overrightarrow{\beta}$  be the fiber factor of the trivial Seifert fibered space  $\overrightarrow{F} \times S^1$ . The space  $\overrightarrow{F} \times S^1$  has two boundary tori  $\overrightarrow{T}_1 = T(\overrightarrow{\alpha}, \overrightarrow{\beta})$  and  $\overrightarrow{T}_2 = T(\overrightarrow{\alpha}', \overrightarrow{\beta})$ . We fix orientations of  $\overrightarrow{F}$  and  $\overrightarrow{\beta}$ .

Let  $J$  be the matrix  $\begin{pmatrix} 1 & 1 \\ 2 & 1 \end{pmatrix}$ . Let  $N'$  be the simple graph manifold obtained from gluing the boundary torus  $\overleftarrow{T}_1$  of  $\overleftarrow{F} \times S^1$  to the boundary torus  $\overrightarrow{T}_1$  of  $\overrightarrow{F} \times S^1$  via the gluing matrix  $J$ . We note that  $N'$  is a simple graph manifold because of  $|\overleftarrow{[\beta]} \wedge \overrightarrow{[\beta]}| = 1$ . To see this, we note that  $\overleftarrow{[\beta]} = 0[\overleftarrow{\alpha}] + \overleftarrow{[\beta]}$  and hence in  $H_1(\overrightarrow{T}_1)$  we have  $\overleftarrow{[\beta]} = ([\overrightarrow{\alpha}], [\overrightarrow{\beta}]) \begin{pmatrix} 1 & 1 \\ 2 & 1 \end{pmatrix} \begin{pmatrix} 0 \\ 1 \end{pmatrix} = [\overrightarrow{\alpha}] + \overrightarrow{[\beta]}$ . Thus  $|\overleftarrow{[\beta]} \wedge \overrightarrow{[\beta]}| = |[\overrightarrow{\alpha}] \wedge \overrightarrow{[\beta]}| = 1$ .

Let  $\overleftarrow{B}$  be the orientable surface with two boundaries  $\overleftarrow{c}_1$  and  $\overleftarrow{c}_2$  with  $n + 1$  genus. Let  $\overrightarrow{B}$  be the orientable surface with four boundaries  $\overrightarrow{c}_1, \overrightarrow{c}_2, \overrightarrow{c}_3, \overrightarrow{c}_4$  and  $2n + 1$  genus. Let  $c_{1,1}$  and  $c_{1,2}$  be oriented simple closed curves in  $\overleftarrow{T}_1$  such that in  $H_1(\overleftarrow{T}_1)$  we have  $[c_{1,1}] = [\overleftarrow{\alpha}] + 2n[\overleftarrow{\beta}]$  and  $[c_{1,2}] = (2n + 1)[\overleftarrow{\alpha}] - 2n[\overleftarrow{\beta}]$ . Applying Lemma 3.3.2 to  $\overleftarrow{F}$ ,  $\overleftarrow{T}_1$ ,  $c_{1,1}$  and  $c_{1,2}$ , there is a

horizontal surface  $\overleftarrow{g} : \overleftarrow{B} \looparrowright \overleftarrow{F} \times S^1$  such that in  $H_1(\overleftarrow{T}_1)$  we have

$$\begin{aligned} [\overleftarrow{g}(\overleftarrow{c}_1)] &= [c_{1,1}] = [\overleftarrow{\alpha}] + 2n[\overleftarrow{\beta}] \\ [\overleftarrow{g}(\overleftarrow{c}_2)] &= [c_{1,2}] = (2n+1)[\overleftarrow{\alpha}] - 2n[\overleftarrow{\beta}] \end{aligned} \quad (*)$$

Since the homeomorphism  $\overleftarrow{T}_1 \rightarrow \overrightarrow{T}_1$  is the gluing matrix  $J$ , it follows that in  $H_1(\overrightarrow{T})$  we have  $[c_{1,1}] = (2n+1)[\overrightarrow{\alpha}] + (2n+2)[\overrightarrow{\beta}]$  and  $[c_{1,2}] = [\overrightarrow{\alpha}] + (2n+2)[\overrightarrow{\beta}]$ . Let  $c_{2,1}$  and  $c_{2,2}$  be oriented simple closed curves in  $\overrightarrow{T}_2$  such that in  $H_1(\overrightarrow{T}_2)$  we have  $[c_{2,1}] = [\overrightarrow{\alpha}'] - (2n+2)[\overrightarrow{\beta}]$  and  $[c_{2,2}] = (2n+1)[\overrightarrow{\alpha}'] - (2n+2)[\overrightarrow{\beta}]$ . Applying Lemma 3.3.2 to  $\overrightarrow{F}$ ,  $\overrightarrow{T}_1$ ,  $\overrightarrow{T}_2$ ,  $c_{1,1}$ ,  $c_{1,2}$ ,  $c_{2,1}$  and  $c_{2,2}$ , there is a horizontal surface  $\overrightarrow{g} : \overrightarrow{B} \looparrowright \overrightarrow{F} \times S^1$  such that in  $H_1(\overrightarrow{T}_1)$  we have

$$\begin{aligned} [\overrightarrow{g}(\overrightarrow{c}_1)] &= [c_{1,1}] = (2n+1)[\overrightarrow{\alpha}] + (2+2n)[\overrightarrow{\beta}] \\ [\overrightarrow{g}(\overrightarrow{c}_2)] &= [c_{1,2}] = [\overrightarrow{\alpha}] + (2n+2)[\overrightarrow{\beta}] \end{aligned} \quad (\dagger)$$

and in  $H_1(\overrightarrow{T}_2)$  we have

$$\begin{aligned} [\overrightarrow{g}(\overrightarrow{c}_3)] &= [c_{2,1}] = [\overrightarrow{\alpha}'] - (2+2n)[\overrightarrow{\beta}] \\ [\overrightarrow{g}(\overrightarrow{c}_4)] &= [c_{2,2}] = (2n+1)[\overrightarrow{\alpha}'] - (2+2n)[\overrightarrow{\beta}] \end{aligned}$$

Since  $\overleftarrow{g}(\overleftarrow{c}_j) = \overrightarrow{g}(\overrightarrow{c}_j)$  in  $T$  with  $j = 1, 2$ , we may paste horizontal surfaces  $\overleftarrow{g} : \overleftarrow{B} \looparrowright \overleftarrow{F} \times S^1$  and  $\overrightarrow{g} : \overrightarrow{B} \looparrowright \overrightarrow{F} \times S^1$  to form a horizontal surface  $g : B_n \looparrowright N'$  where  $B_n$  is formed from  $\overleftarrow{B}$  and  $\overrightarrow{B}$  by gluing. The surface  $B_n$  has two boundary components  $\overrightarrow{c}_3$  and  $\overrightarrow{c}_4$ . We denote  $c_1$  to be the closed curve in  $B_n$  obtained from gluing  $\overleftarrow{c}_1$  to  $\overrightarrow{c}_1$ . We denote  $c_2$  to be the closed curve in  $B_n$  obtained from gluing  $\overleftarrow{c}_2$  to  $\overrightarrow{c}_2$ .

Fix a point  $x$  in the interior of the subsurface  $\overrightarrow{B}$  of  $B_n$ . Let  $\gamma_n$  be an oriented simple closed curve in  $B_n$  such that starting from  $x$  the curve  $\gamma_n$  intersects each circle  $c_1$  and  $c_2$  exactly once. The direction of  $\gamma_n$  determines directed edges  $e_1$  and  $e_2$  in the graph  $\Omega_{B_n}$ . Applying Lemma 3.3.1 to the horizontal surface  $g : B_n \looparrowright N'$  together with equations (\*)

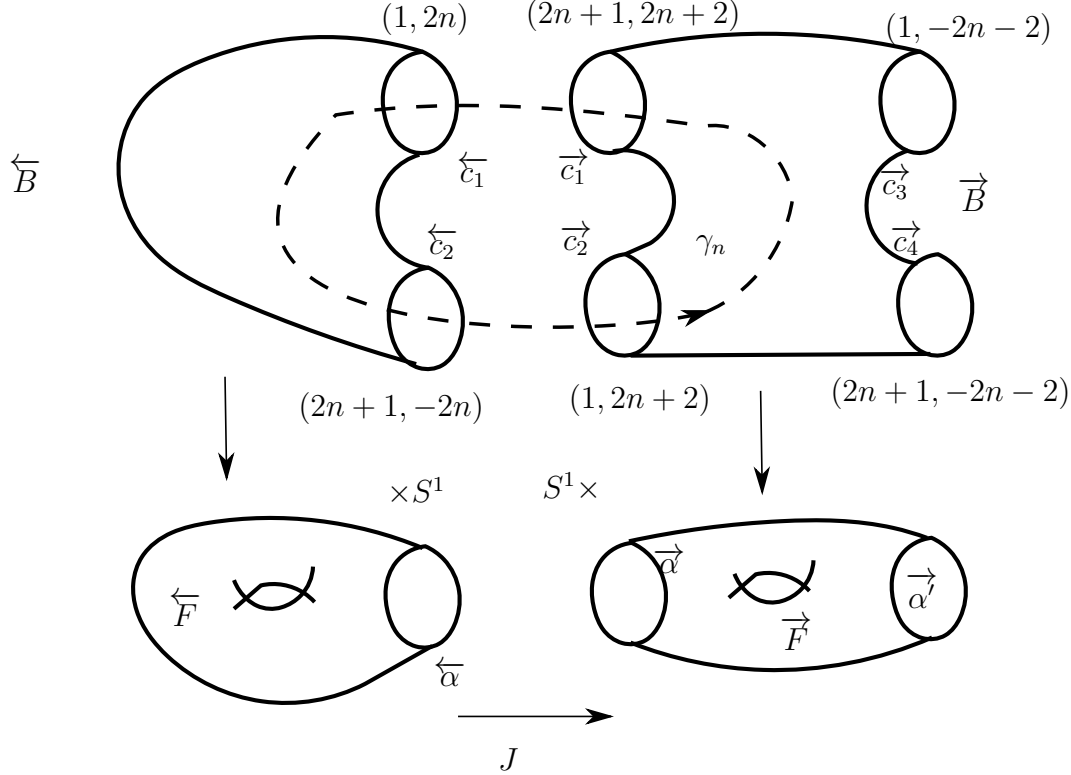

Figure 3.1: The left down arrow illustrates the horizontal surface  $\overleftarrow{g}: \overleftarrow{B} \rightarrow \overleftarrow{F} \times S^1$  and the right down arrow illustrates the horizontal surface  $\overrightarrow{g}: \overrightarrow{B} \rightarrow \overrightarrow{F} \times S^1$  in Lemma 3.4.1. The simple graph manifold  $N'$  is obtained from  $\overleftarrow{F} \times S^1$  to  $\overrightarrow{F} \times S^1$  by gluing the boundary torus  $\overleftarrow{\alpha} \times S^1$  of  $\overleftarrow{F} \times S^1$  to the boundary torus  $\overrightarrow{\alpha} \times S^1$  of  $\overrightarrow{F} \times S^1$  via the gluing matrix  $J$ . We paste  $\overleftarrow{g}$  and  $\overrightarrow{g}$  to form the horizontal surface  $g: B_n \rightarrow N'$ . The oriented curve  $\gamma_n$  in the surface  $B_n$  is shown in the Figure.

and  $(\dagger)$ , we get that  $\mathbf{sl}(e_1) = (2n+1)/1 = 2n+1$  and  $\mathbf{sl}(e_2) = (2n+1)/1 = 2n+1$ . Therefore,  $w(\gamma_n) = \mathbf{sl}(e_1) \cdot \mathbf{sl}(e_2) = (2n+1)^2$ .

We double the surface  $B_n$  along its boundary to get a closed surface, denoted by  $S_n$ . We also double the simple graph manifold  $N'$  along its boundary to get a closed simple graph manifold, denoted by  $N$ . From the horizontal surface  $g: B_n \looparrowright N'$ , after doubling  $B_n$  and  $N'$  along their respective boundaries, we get a canonical a horizontal surface, denoted by  $g_n: S_n \looparrowright N$ . Furthermore, since  $w(\gamma_n) > 1$  it follows that  $g_n: S_n \looparrowright N$  is non-separable. We note that the manifold  $N$  is a closed simple graph manifold with three Seifert blocks and  $S_n$  is a closed surface with three pieces. We note that from the construction of  $g_n: S_n \looparrowright N$ , its governor is  $\epsilon_n = 2n+1$  and the simple closed curve  $\gamma_n$  in  $S_n$  has geometric intersection number with  $g_n^{-1}(\mathcal{T})$  is 2 where  $\mathcal{T}$  is the union of JSJ tori in  $N$ .  $\square$

To get into the proof of Theorem 3.1.3, we need several facts from Section 5 and Section 6 in Chapter 1. Let  $\{S_j \looparrowright N\}_{j \in \mathbb{N}}$  be the collection of non-separable, horizontal surfaces given by Lemma 3.4.1. We equip  $S_j$  with a hyperbolic metric, and we equip  $N$  with a length metric. These metrics induce metrics on the universal covers  $\tilde{S}_j$  and  $\tilde{N}$ , which are denoted by  $d_{\tilde{S}_j}$  and  $d$  respectively. In the following, for any two points  $x$  and  $y$  in  $\tilde{N}$  we denote  $[x, y]$  as a geodesic in  $\tilde{N}$  connecting  $x$  to  $y$ .

Let  $S_n$  be the surface given by Lemma 3.4.1, and let  $\gamma_n$  be the curve given by Lemma 3.4.1. Fact 3.4.2 below is extracted from Section 5 (lower bound of distortion) in Chapter 1, it mainly follows from the proof of Theorem 5.1 in Chapter 1.

**Fact 3.4.2.** Let  $\gamma_n$  be the closed curve in the surface  $S_n$  given by Lemma 3.4.1. Fix a point  $s_0 \in \gamma_n$  such that  $s_0$  belongs to a circle in the collection of circles in  $g_n^{-1}(\mathcal{T})$ . We relabel  $\tilde{s}_0$  by  $\tilde{x}_0$ . There exists a constants  $L \geq 1$  depending on the length of  $\gamma_n$ , and a collection of paths  $\{\rho_j \mid j \in \mathbb{N}\}$  in  $\tilde{S}_n$  (the path  $\rho_j$  is called "double spiral loop" in Chapter 1) such that the following holds.

1. For each  $j \in \mathbb{N}$ , we have  $\tilde{x}_0 = \rho_j(0)$  and  $\tilde{x}_j := \rho_j(1)$  is an element in the orbit  $\pi_1(S_n, s_0)(\tilde{s}_0)$ .
2. For each  $j \in \mathbb{N}$ , we have that  $[\tilde{x}_0, \tilde{x}_j] - \{\tilde{x}_0, \tilde{x}_j\}$  passes through  $4j - 1$  Seifert blocks of  $\tilde{N}$ .
3. For each  $j \in \mathbb{N}$ , we have that

$$d(\tilde{x}_0, \tilde{x}_j) \leq Lj + L \quad \text{and} \quad Lw(\gamma_n)^j \leq d_{\tilde{S}_n}(\tilde{x}_0, \tilde{x}_j).$$

The following fact is extracted from Section 6 (upper bound of distortion) in Chapter 1. It mainly follows from Claim 1 and Claim 2 in the proof of Theorem 6.1 in Chapter 1.

**Fact 3.4.3.** Let  $\epsilon_m > 1$  be the governor of the non-separable, horizontal surface  $g_m: S_m \looparrowright N$ . There exists a constant  $L' \geq 1$  such that the following holds: For any  $x$  and  $y$  in  $\tilde{S}_m$ , let

$k$  be the number of Seifert blocks where  $[x, y] - \{x, y\}$  passes through. Then

$$d_{\tilde{S}_m}(x, y) \leq L' \epsilon_m^k + L' d(x, y).$$

Let  $N$  and  $M$  be closed simple graph manifolds. We equip  $N$  and  $M$  with length metrics, and these metrics induce the metrics in the universal covers  $\tilde{N}$  and  $\tilde{M}$ , denoted by  $d$  and  $d'$  respectively. It is shown by Behrstock-Neumann [BN08] that  $\tilde{N}$  and  $\tilde{M}$  are quasi-isometric.

**Lemma 3.4.4.** *Let  $\varphi: \tilde{N} \rightarrow \tilde{M}$  be a quasi-isometry. There exists a positive constant  $D > 0$  such that the following holds. For any two points  $x$  and  $y$  in  $\tilde{N}$  such that  $x$  and  $y$  belong to JSJ planes of  $\tilde{N}$  and  $[x, y] - \{x, y\}$  passes through  $n$  number of Seifert blocks. Let  $k$  be the number of Seifert blocks where  $[\varphi(x), \varphi(y)] - \{\varphi(x), \varphi(y)\}$  passes through. Then  $k \leq n + D$ .*

*Proof.* By Theorem 1.1 [KL98], there exists a positive constant  $R > 0$  such that for any Seifert block  $B$  in  $\tilde{N}$ , there exists a Seifert block  $B'$  in  $\tilde{M}$  such that the Hausdorff distance  $d_{\mathcal{H}}(B', \varphi(B)) \leq R$ . Moreover, for any JSJ plane  $P$  in  $\tilde{N}$ , there exists a JSJ plane  $P'$  in  $\tilde{M}$  such that  $d_{\mathcal{H}}(\varphi(P), P') \leq R$ .

Let  $\rho > 0$  be the infimum of the set of the distance of any two JSJ planes in  $\tilde{M}$ . We let  $D = 2R/\rho + 2$ . We are going to prove that  $k \leq n + D$ .

Let  $P_0$  and  $P_n$  be the JSJ planes in  $\tilde{N}$  such that  $x \in P_0$  and  $y \in P_n$ . Let  $P'_0$  and  $P'_n$  be the JSJ planes in  $\tilde{M}$  such that  $d_{\mathcal{H}}(\varphi(P_0), P'_0) \leq R$  and  $d_{\mathcal{H}}(\varphi(P_n), P'_n) \leq R$ . It follows that there exist  $x' \in P'_0$  and  $y' \in P'_n$  such that  $d'(\varphi(x), x') \leq R$  and  $d'(\varphi(y), y') \leq R$ .

Let  $a$  be the number of Seifert blocks which  $[\varphi(x), x'] - \{\varphi(x), x'\}$  passes through. Let  $b$  be the number of Seifert blocks which  $[\varphi(y), y'] - \{\varphi(y), y'\}$  passes through. We note that the number of Seifert blocks where  $[x', y'] - \{x', y'\}$  passing through is no more than  $n$ . Thus,  $k \leq a + n + b$ .

Since  $\rho$  is the smallest distance of any two JSJ planes in  $\tilde{M}$ , we have  $\rho(a-1) \leq d'(\varphi(x), x')$  and  $\rho(b-1) \leq d'(\varphi(y), y')$ . Since  $d'(\varphi(x), x') \leq R$  and  $d'(\varphi(y), y') \leq R$ , it follows that  $\rho a \leq R + \rho$  and  $\rho b \leq R + \rho$ . Hence  $a \leq R/\rho + 1$  and  $b \leq R/\rho + 1$ . It follows that

$$k \leq n + a + b \leq n + 2R/\rho + 2 = n + D. \quad \square$$

### 3.5 Proof of the main Theorem

In this section, we give the proof of Theorem 3.1.3 by showing that there is an infinite collection of natural numbers  $\mathcal{F}$  such that the collection of non-separable, horizontal surfaces  $\{g_j: S_j \looparrowright N \mid j \in \mathcal{F}\}$  given by Lemma 3.4.1 satisfy the conclusion of Theorem 3.1.3.

*Proof of Theorem 3.1.3.* For each  $j \in \mathbb{N}$ , let  $S_j \looparrowright N$  be the non-separable, horizontal surface given by Lemma 3.4.1. Let  $\gamma_j$  be the simple closed curve given by Lemma 3.4.1. Let  $\epsilon_j$  be the governor of the horizontal surface  $S_j \looparrowright N$ . We note that  $\epsilon_j = 2j + 1$  and  $w(\gamma_j) = (2j + 1)^2$  by Lemma 3.4.1.

Let  $\mathcal{F}$  be a infinite collection of natural numbers such that for any elements  $n$  and  $m$  in  $\mathcal{F}$  we have  $(2m + 1)^2 < 2n + 1$  whenever  $m < n$  (the existence of this collection is easy to see, for instance, we may define  $\tau(j)$  inductively by letting  $\tau(j + 1) = (2\tau(j) + 1)^2 + 1$  and then we may let  $\mathcal{F} = \{\tau(j) \mid j \in \mathbb{N}\}$ ).

To prove the theorem we only need to show that if  $n$  and  $m$  are two elements  $\mathcal{F}$  such that  $m < n$  then  $(\pi_1(N), \pi_1(S_n))$  and  $(\pi_1(N), \pi_1(S_m))$  are not quasi-isometric. We prove this by contradiction. We briefly describe here how do we get a contradiction. Suppose that  $(\pi_1(N), \pi_1(S_n))$  and  $(\pi_1(N), \pi_1(S_m))$  are quasi-isometric, then we are going to show  $w(\gamma_n) \leq \epsilon_m^4$ . From this inequality and the facts  $\epsilon_j = 2j + 1$  and  $w(\gamma_j) = (2j + 1)^2$ , we get that  $2n + 1 \leq (2m + 1)^2$ . Since  $m, n \in \mathcal{F}$  and  $m < n$ , it follows that  $(2m + 1)^2 < 2n + 1$ . The contradiction comes from two inequalities  $2n + 1 \leq (2m + 1)^2$  and  $(2m + 1)^2 < 2n + 1$ .

We fix a finite generating set  $\mathcal{A}_n$  of  $\pi_1(S_n)$ , a finite generating set  $\mathcal{A}_m$  of  $\pi_1(S_m)$  and a finite generating set  $\mathcal{S}$  of  $\pi_1(N)$  so that  $\mathcal{A}_n \subset \mathcal{S}$  and  $\mathcal{A}_m \subset \mathcal{S}$ . We note that  $\mathcal{S}$  depends on the choice of  $m$  and  $n$ . Assume that  $(\pi_1(N), \pi_1(S_n))$  and  $(\pi_1(N), \pi_1(S_m))$  are quasi-isometric, it follows that  $(\tilde{N}, \tilde{S}_m)$  and  $(\tilde{N}, \tilde{S}_n)$  are quasi-isometric by Lemma 3.2.8. Hence, there exists a positive constant  $L_1$  and an  $(L_1, L_1)$ -quasi-isometry map  $\varphi: \tilde{N} \rightarrow \tilde{N}$  such that  $\varphi(\tilde{S}_n) \subseteq \tilde{S}_m$

and  $\tilde{S}_m \subseteq \mathcal{N}_{L_1}(\varphi(\tilde{S}_n))$ .

Let  $L \geq 1$  be the constant given by Fact 3.4.2 with respect to the horizontal surface  $S_n \looparrowright N$ . Let  $L' \geq 1$  be the constant given by Fact 3.4.3 with respect to the horizontal surface  $S_m \looparrowright N$ . Let  $A = \max\{L, L', L_1\}$ .

Let  $\{\tilde{x}_j \mid j \in \mathbb{N}\}$  be the collection of points given by Fact 3.4.2. Let  $D$  be the constant given by Lemma 3.4.4. We first claim that

$$d_{\tilde{S}_m}(\varphi(\tilde{x}_0), \varphi(\tilde{x}_j)) \leq A\epsilon_m^{4j+D} + A^3j + A^3 + A^2 \quad (**)$$

Indeed, From Fact 3.4.2 we have

$$d(\tilde{x}_0, \tilde{x}_j) \leq Aj + A \text{ and } w(\gamma_n)^j \leq A d_{\tilde{S}_n}(\tilde{x}_0, \tilde{x}_j)$$

Using the above inequality and the fact  $\varphi$  is a  $(A, A)$ -quasi-isometry, we get that

$$d(\varphi(\tilde{x}_0), \varphi(\tilde{x}_j)) \leq A d(\tilde{x}_0, \tilde{x}_j) + A \leq A(Aj + A) + A = A^2j + A^2 + A$$

We recall that  $[\tilde{x}_0, \tilde{x}_j] - \{\tilde{x}_0, \tilde{x}_j\}$  passes through  $2j$  Seifert blocks of  $\tilde{N}$ . Let  $[\varphi(\tilde{x}_0), \varphi(\tilde{x}_j)]$  be a geodesic in  $\tilde{N}$  connecting  $\varphi(\tilde{x}_0)$  to  $\varphi(\tilde{x}_j)$ . Let  $k$  be the number of Seifert blocks of  $\tilde{N}$  where  $[\varphi(\tilde{x}_0), \varphi(\tilde{x}_j)] - \{\varphi(\tilde{x}_0), \varphi(\tilde{x}_j)\}$  passes through. By Lemma 3.4.4, we have that  $k \leq 2j + D$ . Using Fact 3.4.3, the above inequality  $d(\varphi(\tilde{x}_0), \varphi(\tilde{x}_j)) \leq A^2j + A^2 + A$ , and  $k \leq 4j + D$  we get that

$$\begin{aligned} d_{\tilde{S}_m}(\varphi(\tilde{x}_0), \varphi(\tilde{x}_j)) &\leq A\epsilon_m^k + Ad(\varphi(\tilde{x}_0), \varphi(\tilde{x}_j)) \\ &\leq A\epsilon_m^k + A(A^2j + A^2 + A) \\ &\leq A\epsilon_m^k + A^3j + A^3 + A^2 \leq A\epsilon_m^{4j+D} + A^3j + A^3 + A^2 \end{aligned}$$

Thus  $(**)$  is established.

By Lemma 3.2.7, there exists constant  $\xi > 0$  such that

$$d_{\tilde{S}_n}(\tilde{x}_0, \tilde{x}_j) \leq \xi d_{\tilde{S}_m}(\varphi(\tilde{x}_0), \varphi(\tilde{x}_j)) + \xi$$

for all  $j$ .

We use Fact 3.4.2, the above inequality, and (\*\*) to get that

$$\begin{aligned} w(\gamma_n)^j &\leq A d_{\tilde{S}_n}(\tilde{x}_0, \tilde{x}_j) \\ &\leq A (\xi d_{\tilde{S}_m}(\varphi(\tilde{x}_0), \varphi(\tilde{x}_j)) + \xi) \\ &= A \xi d_{\tilde{S}_m}(\varphi(\tilde{x}_0), \varphi(\tilde{x}_j)) + A \xi \\ &\leq A \xi (A \epsilon_m^k + A^3 j + A^3 + A^2) + A \xi \\ &\leq A \xi (A \epsilon_m^{4j+D} + A^3 j + A^3 + A^2) + A \xi \\ &= A^2 \xi \epsilon_m^{4j+D} + A^4 \xi j + A^4 \xi + A^3 \xi + A \xi \end{aligned}$$

We divide both sides of the inequality

$$w(\gamma_n)^j \leq A^2 \xi \epsilon_m^{4j+D} + A^4 \xi j + A^4 \xi + A^3 \xi + A \xi$$

by  $\epsilon_m^{4j}$  to get that

$$\left( w(\gamma_n) / \epsilon_m^4 \right)^j \leq A^2 \xi \epsilon_m^D + A^4 \xi j / \epsilon_m^{4j} + (A^4 \xi + A^3 \xi + A \xi) / \epsilon_m^{4j}$$

for all  $j \in \mathbb{N}$ .

Since  $\epsilon_m > 1$ , we have

$$\lim_{j \rightarrow \infty} \left( A^2 \xi \epsilon_m^D + A^4 \xi j / \epsilon_m^{4j} + (A^4 \xi + A^3 \xi + A \xi) / \epsilon_m^{4j} \right) = A^2 \xi \epsilon_m^D.$$

Hence  $\lim_{j \rightarrow \infty} \left( w(\gamma_n) / \epsilon_m^4 \right)^j \leq A^2 \xi \epsilon_m^D$ . It follows that  $w(\gamma_n) / \epsilon_m^4 \leq 1$ , otherwise we will get

$\infty \leq A^2 \xi \epsilon_m^D$ . Thus

$$w(\gamma_n) \leq \epsilon_m^4$$

Since  $w(\gamma_n) = (2n + 1)^2$  and  $\epsilon_m = 2m + 1$ , it follows that  $(2n + 1)^2 \leq (2m + 1)^4$ . Hence  $2n + 1 \leq (2m + 1)^2$ .

We note that  $m < n$  and  $m, n \in \mathcal{F}$ , thus by the definition of  $\mathcal{F}$  we have  $(2m + 1)^2 < 2n + 1$ . Combining two inequalities  $2n + 1 \leq (2m + 1)^2$  and  $2n + 1 < (2m + 1)^2$ , we have  $n < n$ , a contradiction. The theorem is established.  $\square$

## 3.6 Appendix

In this section, we give an evidence supporting Conjecture 3.1.4 by showing that other geometric invariants in literature such as subgroup distortion,  $k$ -volume distortion, relative upper divergence, relative lower divergence could not be used to distinguish quasi-isometry of pairs of separable, horizontal surfaces in graph manifolds.

### 3.6.1 $k$ -volume distortion

$k$ -volume distortion ( $k \geq 1$ ) is a notion introduced by Bennett [Ben11]. We remark that this notion agrees with subgroup distortion when  $k = 1$  and area distortion (introduced by Gersten [Ger96]) when  $k = 2$ . We refer the reader to [Ben11] for a precise definition of  $k$ -volume distortion.

**Proposition 3.6.1.** *Let  $S \looparrowright N$  be a separable, horizontal surface in a graph manifold  $N$ . Then the  $k$ -volume distortion of  $\pi_1(S)$  in  $\pi_1(N)$  is quadratic when  $k = 1$ , is linear when  $k = 2$  and is trivial when  $k \geq 3$ .*

*Proof.* 1-volume distortion (i.e, subgroup distortion) of  $\pi_1(S)$  in  $\pi_1(N)$  is quadratic (see Chapter 1). We are going to show that 2-volume distortion (i.e, area subgroup distortion) of  $\pi_1(S)$  in  $\pi_1(N)$  is linear. Indeed, the paragraph after Proposition 5.4 in [Ger96] shows that

if the Dehn function of  $\pi_1(S)$  is linear then 2-volume distortion of  $\pi_1(S)$  in  $\pi_1(N)$  is linear. Since Dehn function of the fundamental group of a hyperbolic surface is linear. The claim is confirmed. Finally, we consider the case  $k \geq 3$ . Since there is no  $k$ -cell in the universal cover  $\tilde{S}$ , it follows from the definition of  $k$ -volume distortion that  $k$ -volume distortion ( $k \geq 3$ ) of  $\pi_1(S)$  in  $\pi_1(N)$  is trivial.  $\square$

### 3.6.2 Relative divergence

In [Tra15], Tran introduces the notions of relative upper divergence and relative lower divergence of a pair of finitely generated groups  $H \leq G$ , denoted by  $Div(G, H)$  and  $div(G, H)$  respectively, and shows that relative upper divergence and relative lower divergence are quasi-isometric invariants (see Proposition 4.3 and Proposition 4.9 in [Tra15]). Since relative upper divergence and relative lower divergence are quite technical and we only use results established in [Tra15], [Tra17], we refer the reader to [Tra15] for a precise definition.

**Proposition 3.6.2.** *Let  $g: (S, s_0) \looparrowright (N, x_0)$  be a separable, horizontal surface in a graph manifold  $N$ . Let  $G = \pi_1(N, x_0)$  and  $H = \pi_1(S, s_0)$ . Then  $Div(G, H)$  is quadratic and  $div(G, H)$  is linear.*

If a horizontal surface  $g: S \looparrowright N$  is separable then there exist finite covers  $\hat{S} \rightarrow S$  and  $\hat{N} \rightarrow N$  such that  $\hat{N}$  is an  $\hat{S}$ -bundle over  $S^1$  (see [WY97]). Relative upper divergence and relative lower divergence are unchanged when passing to subgroups of finite index, so for the rest of this section, without loss generality we assume the graph manifold  $N$  fibers over  $S^1$  with the fiber  $S$ . We remark that  $N$  is the mapping torus of a homeomorphism  $f \in \text{Aut}(S)$ . In particular, if we let  $G = \pi_1(N)$  and  $H = \pi_1(S)$ , then  $G = H \rtimes_{\phi} \mathbb{Z}$ , where  $\phi \in \text{Aut}(H)$  is an automorphism induced by  $f$ . We note that that the distortion of  $\pi_1(S)$  in  $\pi_1(N)$  is quadratic as  $S$  is embedded in  $N$ .

The proof of Proposition 3.6.2 is a combination of Lemma 3.6.3 and Lemma 3.6.6.

**Lemma 3.6.3.**  *$Div(G, H)$  is at most quadratic and  $div(G, H)$  is linear.*

*Proof.* We note that  $G = H \rtimes_{\phi} \mathbb{Z}$ , where  $\phi \in \text{Aut}(H)$ . We fix finite generating sets  $\mathcal{A}$  and  $\mathcal{B}$  of  $H$  and  $G$  respectively. By Proposition 4.3 in [Tra17] we have  $\text{Div}(G, H) \preceq \Delta_H^G$ . Since  $H$  is quadratically distorted in  $G$ , it follows that  $\text{Div}(G, H) \preceq n^2$ .

To see that  $\text{div}(G, H)$  is linear, it suffices to show  $\text{div}(G, H)$  is dominated by a linear function (because  $\text{div}(G, H)$  is always bounded below by a linear function). Since  $H$  is a normal subgroup in  $G$ , by Theorem 5.4 in [Tra15] we have  $\text{div}(G, H) \preceq \text{dist}_H^G$  where  $\text{dist}_H^G(n) = \min\{|h|_{\mathcal{A}} \mid h \in H, |h|_{\mathcal{B}} \geq n\}$ . We fix a circle  $c$  in  $g^{-1}(\mathcal{T})$  where  $\mathcal{T}$  is the collection of JSJ tori of  $N$ . Let  $K = \pi_1(c)$ . We note that  $K$  is undistorted in  $G$ . By Theorem 3.6 and Proposition 3.5 in [Tra15], we have  $\text{dist}_H^G \preceq \text{dist}_K^G \preceq \Delta_K^G$ . It follows that  $\text{dist}_H^G$  is dominated by a linear function because  $K$  is undistorted in  $G$ .  $\square$

**Definition 3.6.4.** The divergence of a bi-infinite quasi-geodesic  $\alpha$ , denoted by  $\text{Div}(\alpha)$ , is a function  $g: (0, \infty) \rightarrow (0, \infty)$  which for each positive number  $r$  the value  $g(r)$  is the infimum on the lengths of all paths outside the open ball with radius  $r$  about  $\alpha(0)$  connecting  $\alpha(-r)$  to  $\alpha(r)$ .

The following lemma is proved implicitly in [Tra17]. We use it in the proof of Lemma 3.6.6.

**Lemma 3.6.5.** *Suppose that there exists an element  $h$  in  $H$  with infinite order such that the map  $\alpha: \mathbb{Z} \rightarrow G$  determined by  $\alpha(n) = h^n$  is an  $(L, C)$ -quasi-isometric embedding. Then  $\text{Div}(\alpha) \preceq \text{Div}(G, H)$ .*

**Lemma 3.6.6.**  *$\text{Div}(G, H)$  is at least quadratic.*

*Proof.* We equip  $N$  with a Riemannian metric and this metric induces a metric on the universal cover  $\tilde{N}$ , denoted by  $d$ . We equip  $S$  with a hyperbolic metric and this metric induces a metric on the universal cover  $\tilde{S}$ , denoted by  $d_{\tilde{S}}$ .

Let  $\mathcal{T}$  be the JSJ decomposition of  $N$ . Choose a geodesic loop  $\gamma$  such that  $\gamma$  and  $g^{-1}(\mathcal{T})$  has non-trivial geometric intersection number (see Lemma 3.3 in Chapter 1 for the existence of such a loop  $\gamma$ ). We also assume that  $s_0 \in \gamma$ . Let  $h = [\gamma] \in \pi_1(S, s_0)$ . We note that  $h$  has infinite order. Let  $\alpha: \mathbb{Z} \rightarrow G$  be determined by  $\alpha(n) = h^n$ , and let  $\beta: \mathbb{Z} \rightarrow \tilde{N}$  be

determined by  $\beta(n) = h^n \cdot \tilde{s}_0$  for each  $n \in \mathbb{Z}$ . We will show that  $\beta$  is a quasi-geodesic and  $Div(\beta)$  is at least quadratic and thus it follows that  $\alpha$  is a quasi-geodesic and  $Div(\alpha)$  is at least quadratic. We then apply Lemma 3.6.5 to get that  $Div(G, H)$  is at least quadratic.

We are going to show  $\beta$  is a quasi-geodesic. Let  $\tilde{\gamma}$  be the path lift of  $\gamma$  based at  $\tilde{s}_0$ . Let  $k$  be the number of Seifert blocks of  $\tilde{N}$  where  $\tilde{\gamma}$  passes through. It follows that a geodesic  $[h^n \cdot \tilde{s}_0, h^m \cdot \tilde{s}_0]$  in  $\tilde{N}$  passes through  $k|m - n|$  Seifert blocks in  $\tilde{N}$ . Let  $\rho$  be the shortest distance of any two JSJ planes in  $\tilde{N}$ . It follows that  $\rho k|m - n| \leq d(h^n \cdot \tilde{s}_0, h^m \cdot \tilde{s}_0) = d(\beta(n), \beta(m))$ . Since  $\pi_1(S)$  is a hyperbolic group, it follows that there is  $A > 0$  such that  $\beta$  is an  $(A, A)$ -quasi-geodesic in  $\tilde{S}$  with respect to  $d_{\tilde{S}}$ -metric. Hence, for any  $n, m \in \mathbb{Z}$  we have  $d_{\tilde{S}}(\beta(n), \beta(m)) \leq A|m - n| + A$ . Since  $d(\beta(n), \beta(m)) \leq d_{\tilde{S}}(\beta(n), \beta(m))$ , it follows that  $d(\beta(n), \beta(m)) \leq A|m - n| + A$ . Let  $L = \max\{A, 1/k\rho\}$ , we easily see that  $\beta$  is an  $(L, L)$ -quasi-geodesic.

We are now going to show  $Div(\beta)$  is at least quadratic. Lift the JSJ decomposition of the graph manifold  $N$  to the universal cover  $\tilde{N}$ , and let  $T_N$  be the tree dual to this decomposition of  $\tilde{N}$ . We note that  $h$  acts hyperbolically on the tree  $T_N$  in the sense that there exists a vertex  $v \in T_N$  and there exists a bi-infinite geodesic  $\gamma$  in  $T_N$  such that  $\{h^j v \mid j \in \mathbb{Z}\}$  is an unbounded subset of  $\gamma$ . By Proposition 3.7 in [Sis11], it follows that  $h$  is a contracting element in  $\pi_1(N)$ , and hence  $h$  is Morse element in  $\pi_1(N)$  (see Lemma 2.9 in [Sis11]). Thus,  $\beta$  is a Morse quasi-geodesic in  $(\tilde{N}, d)$ . By Theorem 1.1 in [KL98], there exists a CAT(0) space  $(X, d')$  such that  $(\tilde{N}, d)$  and  $(X, d')$  are bilipschitz homeomorphism. It shown in [BDt14] (see also in [Sul14]) that divergence of a Morse bi-infinite quasi-geodesic is at least quadratic. Hence, the divergence of the image of  $\beta$  in  $(X, d')$  under the bilipschitz homeomorphism  $(\tilde{N}, d) \rightarrow (X, d')$  is at least quadratic. It follows that  $Div(\beta)$  in  $\tilde{N}$  is at least quadratic.  $\square$

*Proof of Proposition 3.6.2.* The proof is a combination of Lemma 3.6.3 and Lemma 3.6.6.  $\square$

# Bibliography

- [Ago] I. Agol. Tameness of hyperbolic 3-manifolds. arXiv:math/0405568.
- [Ago13] I. Agol. The virtual Haken conjecture. *Doc. Math.*, 18:1045–1087, 2013. With an appendix by Agol, Daniel Groves, and Jason Manning.
- [BBI01] D. Burago, Y. Burago, and S. Ivanov. *A course in metric geometry*, volume 33 of *Graduate Studies in Mathematics*. American Mathematical Society, Providence, RI, 2001.
- [BDt14] Jason Behrstock and Cornelia Druţu. Divergence, thick groups, and short conjugators. *Illinois J. Math.*, 58(4):939–980, 2014.
- [Ben11] Hanna Bennett. Volume distortion in groups. *Algebr. Geom. Topol.*, 11(2):655–690, 2011.
- [BN08] Jason A. Behrstock and Walter D. Neumann. Quasi-isometric classification of graph manifold groups. *Duke Math. J.*, 141(2):217–240, 2008.
- [Bon86] Francis Bonahon. Bouts des variétés hyperboliques de dimension 3. *Ann. of Math. (2)*, 124(1):71–158, 1986.
- [Bow93] B. H. Bowditch. Geometrical finiteness for hyperbolic groups. *J. Funct. Anal.*, 113(2):245–317, 1993.
- [BS04] S.V. Buyalo and P.V. Svetlov. Topological and geometric properties of graph manifolds. *Algebra i Analiz*, 16(2):3–68, 2004.

- [Can96] Richard D. Canary. A covering theorem for hyperbolic 3-manifolds and its applications. *Topology*, 35(3):751–778, 1996.
- [CG06] Danny Calegari and David Gabai. Shrinkwrapping and the taming of hyperbolic 3-manifolds. *J. Amer. Math. Soc.*, 19(2):385–446, 2006.
- [DtK18] Cornelia Drutu and Michael Kapovich. *Geometric group theory*, volume 63 of *American Mathematical Society Colloquium Publications*. American Mathematical Society, Providence, RI, 2018. With an appendix by Bogdan Nica.
- [FLP12] Albert Fathi, François Laudenbach, and Valentin Poénaru. *Thurston’s work on surfaces*, volume 48 of *Mathematical Notes*. Princeton University Press, Princeton, NJ, 2012. Translated from the 1979 French original by Djun M. Kim and Dan Margalit.
- [FM12] B. Farb and D. Margalit. *A primer on mapping class groups*, volume 49 of *Princeton Mathematical Series*. Princeton University Press, Princeton, NJ, 2012.
- [Ger94] S.M. Gersten. Quadratic divergence of geodesics in CAT(0) spaces. *Geom. Funct. Anal.*, 4(1):37–51, 1994.
- [Ger96] S. M. Gersten. Preservation and distortion of area in finitely presented groups. *Geom. Funct. Anal.*, 6(2):301–345, 1996.
- [GH90] É. Ghys and P. de la Harpe, editors. *Sur les groupes hyperboliques d’après Mikhael Gromov*, volume 83 of *Progress in Mathematics*. Birkhäuser Boston, Inc., Boston, MA, 1990.
- [Has87] Joel Hass. Minimal surfaces in manifolds with  $S^1$  actions and the simple loop conjecture for Seifert fibered spaces. *Proc. Amer. Math. Soc.*, 99(2):383–388, 1987.

- [HK09] G. Christopher Hruska and Bruce Kleiner. Erratum to: “Hadamard spaces with isolated flats” [Geom. Topol. **9** (2005), 1501–1538; mr2175151]. *Geom. Topol.*, 13(2):699–707, 2009.
- [HP15] M.F. Hagen and P. Przytycki. Cocompactly cubulated graph manifolds. *Israel J. Math.*, 207(1):377–394, 2015.
- [Hru10] G. Christopher Hruska. Relative hyperbolicity and relative quasiconvexity for countable groups. *Algebr. Geom. Topol.*, 10(3):1807–1856, 2010.
- [Joh79] K. Johannson. *Homotopy equivalences of 3-manifolds with boundaries*, volume 761 of *Lecture Notes in Mathematics*. Springer, Berlin, 1979.
- [JS79] W.H. Jaco and P.B. Shalen. Seifert fibered spaces in 3-manifolds. *Mem. Amer. Math. Soc.*, 21(220):1–192, 1979.
- [KL98] M. Kapovich and B. Leeb. 3-manifold groups and nonpositive curvature. *Geom. Funct. Anal.*, 8(5):841–852, 1998.
- [Lee95] Bernhard Leeb. 3-manifolds with(out) metrics of nonpositive curvature. *Invent. Math.*, 122(2):277–289, 1995.
- [Liu17] Yi Liu. A characterization of virtually embedded subsurfaces in 3-manifolds. *Trans. Amer. Math. Soc.*, 369(2):1237–1264, 2017.
- [MSW11] Lee Mosher, Michah Sageev, and Kevin Whyte. Quasi-actions on trees II: Finite depth Bass-Serre trees. *Mem. Amer. Math. Soc.*, 214(1008):vi+105, 2011.
- [Neu01] W.D. Neumann. Immersed and virtually embedded  $\pi_1$ -injective surfaces in graph manifolds. *Algebr. Geom. Topol.*, 1:411–426, 2001.
- [Ngu] H.T. Nguyen. Distortion of surfaces in 3-manifolds. Preprint. arXiv:1805.01094 [math.GR].

- [Pau05] G. Paulik. *Gluing spaces and analysis*. Bonner Mathematische Schriften [Bonn Mathematical Publications], 372. Universität Bonn, Mathematisches Institut, Bonn, 2005. Dissertation, Rheinische Friedrich-Wilhelms-Universität Bonn, Bonn, 2005.
- [PW14a] P. Przytycki and D.T. Wise. Separability of embedded surfaces in 3-manifolds. *Compos. Math.*, 150(9):1623–1630, 2014.
- [PW14b] Piotr Przytycki and Daniel T. Wise. Graph manifolds with boundary are virtually special. *J. Topol.*, 7(2):419–435, 2014.
- [RW98] J.H. Rubinstein and S. Wang.  $\pi_1$ -injective surfaces in graph manifolds. *Comment. Math. Helv.*, 73(4):499–515, 1998.
- [Sch95] Richard Evan Schwartz. The quasi-isometry classification of rank one lattices. *Inst. Hautes Études Sci. Publ. Math.*, 82:133–168 (1996), 1995.
- [Sco78] P. Scott. Subgroups of surface groups are almost geometric. *J. London Math. Soc.* (2), 17(3):555–565, 1978.
- [Sis11] A. Sisto. Contracting elements and random walks. Preprint. arXiv:1112.2666 [math.GT], December 2011.
- [Sta83] J.R. Stallings. Topology of finite graphs. *Invent. Math.*, 71(3):551–565, 1983.
- [Sul14] Harold Sultan. Hyperbolic quasi-geodesics in CAT(0) spaces. *Geom. Dedicata*, 169:209–224, 2014.
- [Sun] H. Sun. A characterization on separable subgroups of 3-manifold groups. Preprint. arXiv:1805.08580 [math.GT].
- [Thu79] W.P. Thurston. *The geometry and topology of 3-manifolds.*, Princeton Lecture Notes, 1979.

- [Tid] J. Tidmore. Cocompact cubulations of mixed 3-manifolds. Preprint. arXiv:1612.06272 [math.GR].
- [Tra15] Hung Cong Tran. Relative divergence of finitely generated groups. *Algebr. Geom. Topol.*, 15(3):1717–1769, 2015.
- [Tra17] Hung Cong Tran. Geometric embedding properties of Bestvina-Brady subgroups. *Algebr. Geom. Topol.*, 17(4):2499–2510, 2017.
- [Wis12a] D.T. Wise. *From riches to RAAGs: 3-manifolds, right-angled Artin groups, and cubical geometry*, volume 117 of *CBMS Regional Conference Series in Mathematics*. Published for the Conference Board of the Mathematical Sciences, Washington, DC; by the American Mathematical Society, Providence, RI, 2012.
- [Wis12b] D.T. Wise. The structure of groups with a quasiconvex hierarchy. Preprint, 2012.
- [Woo16] D.J. Woodhouse. Classifying finite dimensional cubulations of tubular groups. *Michigan Math. J.*, 65(3):511–532, 2016.
- [WY97] S. Wang and F. Yu. Graph manifolds with non-empty boundary are covered by surface bundles. *Math. Proc. Cambridge Philos. Soc.*, 122(3):447–455, 1997.

## CURRICULUM VITAE

**Hoang Thanh Nguyen**

**Place of birth:** VietNam

**Education:**

B.S., Da Nang University of Education-Viet Nam, May 2011

Major: Mathematics

Lecturer., Danang Univeristy of Education-Vietnam, August 2011- June 2012.

M.S., New Mexico Sate University, December 2013

Major: Mathematics

Ph.D., University of Wisconsin-Milwaukee, expected May 2019

Advisor: Christopher Hruska

**Research Interests:**

Geomtric group theory, low dimensional topology

**Dissertation Title:** Large scale geometry of surfaces in 3-manifolds

**Published/Accepted papers:**

- 1) Distortion of surfaces in graph manifolds (with Chris Hruska.) *Algebraic & Geometric Topology* 19 (2019) 363-395.
- 2) Quasi-isometry of pairs: surfaces in graph manifolds. *International Journal of Algebra and Computation*; <https://doi.org/10.1142/S0218196719500218>
- 3) On the coarse geometry of right-angled Coxeter groups. (with H.C.Tran). To appear in *Algebraic & Geometric Topology*

**Preprints/Submitted papers:**

4) Distortion of surfaces in 3-manifolds. Under revision at the *Journal of Topology*.

5) On boundaries of relatively hyperbolic right-angled Coxeter groups. (with H.C.Tran, M. Haulmark.) *Submitted*

**In preparation:**

6) Subgroup distortion of 3-manifold groups (with Hongbin Sun).