

**Rapid Bridge Construction Technology:
Precast Elements for Substructures**

by

Demirhan Unlu

A thesis in partial fulfillment of the requirements for the degree of

Master of Science

(Civil Engineering)

at the

UNIVERSITY OF WISCONSIN - MADISON

2010

Rapid Bridge Construction Technology:

Precast Elements for Substructures

APPROVED BY:

DATE:

Dr. Michael G. Oliva
Major Advisor
Professor of Civil and Environmental Engineering
University of Wisconsin - Madison

Abstract

This thesis elaborates on the ongoing efforts of University of Wisconsin – Madison and Wisconsin DOT to utilize precast technology for bridge substructures in Wisconsin as a rapid construction technique. Decreasing the negative outcomes of detours for the traveling public and freight transportation during bridge replacement projects is the main advantage of the precast construction in addition to improving work zone safety, allowing the use of innovative materials, introducing better in plant quality control and lessening the environmental impact. The use of precast concrete for bridge superstructures has long been known and practiced. Various precast substructure elements have been used throughout the world resulting in successful projects. After the better understanding of the importance of the project time in replacement projects, Wisconsin also started to shift to accelerated construction techniques. The last two projects, Baldwin Bridge on USH 63 in Croix County of Wisconsin and Mississippi Slough Bridges on Wisconsin Highway 25 which use precast substructure elements, clearly show these efforts.

After evaluating the characteristics of current cast in place abutments, piers, pier caps and foundations, the components that are the most advantageous for precasting were already determined and specific systems have been developed during a first phase of research completed by Okumus⁴⁶. Precast abutments and pier caps are observed to be the most suitable elements for standardizing and are the focus of this research as well, which is the extension of the first precast substructures project. Modules of reasonable weight under permissible limit for Wisconsin and sizes, accordingly, are defined. Easy to implement connection details with enough strength were identified for the systems. Standardization was

given special attention to allow repetition, reuse of forms and provide familiarity of details for contractors. Especially for this research, it is decided that the same bent cap system will be used for piers, pile caps and in some abutments which will increase the repetitive nature of the system. Through regular interaction with DOT engineers and the precast manufacturers, alternative guidelines, design examples and standard plans are being prepared as end products. It is believed that future projects such as the ones mentioned before, with precast abutments will help improve the system more and show efficiency of precast substructure use in Wisconsin and make both design engineers and contractors more familiar with the system resulting in a lower project cost.

Acknowledgements

Throughout the graduate study that I have been undertaking in University of Wisconsin – Madison, there have been so many great people that helped me.

Above all, I would like to thank profoundly to my major advisor Professor Michael G. Oliva, without whom there would never be such a spectacular opportunity for me, for his invaluable guidance, understanding and inspirational profile as an academician.

Pinar Okumus, who has been my family in States, is also deeply appreciated for her presence in my life as a friend and mentor. Your unrequited help and advice have always been a roadmap throughout the time that I have spent in Madison.

The cutest couple in the world, Karaesmen family, is gratefully thanked for their endless support about any topic that someone can think of. You have been the starting point of this time interval of my life.

Engineers in Wisconsin Department of Transportation, who made this research possible by providing funding, are sincerely appreciated.

I also owe my fellow graduate students, Gregory Rajek, Jake Effinger, Miguel Azócar, Derek Scullion a debt of gratitude for their friendship. Being around you and spending time with you have always been fun for me.

Last but not least, father, mother and brother, you have always been my reason to be alive. One of the very first of my goals is to make you proud. Your endless encouragements, which will make me succeed anything, lead me always in my life. Father, I know that your soul has always been with me and the strength that I am getting from that cannot be

compared to any other thing. No matter what I do in my life, it will always be attributed to you as well.

List of Figures

Figure 2-1 – Precast footing module with a shear key and splice detail getting placed on subfooting ⁴	8
Figure 2-2 - Single piece abutment stem and partial footing ⁹	10
Figure 2-3 – Vertically separated modules connected with grouted shear keys ⁴	11
Figure 2-4 – Details of post tensioning to be used for lateral connection of two abutment modules ¹⁰	12
Figure 2-5 – Welding the precast modules together ¹¹	13
Figure 2-6 – Precast abutment with block-outs, being placed on steel H piles ¹⁵	14
Figure 2-7 – The steel piles in front of the abutment body and the welding process ¹⁶	15
Figure 2-8 – Post-tensioning dowels in the footing ¹⁷	16
Figure 2-9 – Precast abutment pin connected to the footing ⁵	17
Figure 2-10 – Single piece pier module ¹⁶	18
Figure 2-11 – Precast pier module with an hammerhead extension to form the pier cap later ²⁰	19
Figure 2-12 – Precast I piers connected to the adjacent elements by post-tensioning ²²	20
Figure 2-13 – Erection of precast box pier section ²³	21
Figure 2-14 – Completed precast segmental pier of US 183 Bridge, Austin ^{6, 24}	22
Figure 2-15 – Several pier frame configurations using the system proposed ²⁶	23
Figure 2-16 – Precast concrete cap shell shown with pile reinforcement and the girders in place, ready for concrete casting in the center region ²⁸	24
Figure 2-17 – Precast pile cap with pockets visible ready to accommodate the connectors ³⁰	26

Figure 2-18 – Dowels protruding from the columns are inserted in the ducts in the cap ³⁰	27
Figure 2-19 – Precast cross head with sleeves ³¹	28
Figure 2-20 – Post tensioned cap to column connection detail ³²	29
Figure 2-21 – Cross sectional view (left) and erection (right) of pile to pile cap connection ³⁴	30
Figure 2-22 – Splice Sleeve Detail ⁶	31
Figure 3-1 – Frequency of use of various abutment and pier types.....	35
Figure 3-2 – Summary of the Standard Abutment Module Dimensions	38
Figure 3-3 – Possible joint locations marked for a modularized precast pier cap	40
Figure 3-4 – Abutment module to module connection methods: Spliced Sleeves (top left), Post tensioning ³⁷ (top right), Cast in place closure joints ¹² (bottom left), Welding ¹¹ (bottom right).....	42
Figure 3-5 – Example shear key vertical abutment to abutment connection ⁴	43
Figure 3-6 – Wingwall as a combination of the precast abutment module at the bottom and the cast in place portion at the top which also provides the connection	45
Figure 3-7 – Pile to Abutment Connection methods: Embedded connection ¹⁵ (left), Welded connection ¹¹ (right).....	46
Figure 3-8 – Pier Cap to Column connections: Bolted connection ³⁸ (left), connection by splice sleeves ³⁵ (middle), grouted duct connection ³⁰ (right).....	47
Figure 3-9 – Grouted Pocket Connection with Pier Partially Embedded in Cap ³⁰	48
Figure 3-10 – Connector bar configurations for 36in. diameter pier: Configuration I (left), Configuration II (right)	51

Figure 3-11 – N-M envelopes for grouted pockets and the reactions enveloped	52
Figure 4-1– Traditional Cost and User Related Costs with High and Low Volume Traffics with respect to Time ³⁹	55
Figure 4-2 – Total Cost which Includes the Traditional and User Related Costs and the Traditional Cost Curve Only ³⁹	56
Figure 5-1 – The Standard Precast Abutment Modules.....	59
Figure 5-2 – The Standard Precast Pier/Bent Cap	60
Figure 6-1 – Cross section of the abutment segment.....	64
Figure 6-2 – Setting the second abutment module in place	65
Figure 7-1 – Erection of Precast Pier Cap ⁴⁰	69
Figure 7-2 – Precast Abutment used in Michigan’s Replacement Project ⁴²	70
Figure 8-1 – Isometric View of Welded Steel Plate Connection.....	74
Figure 8-2 – Cross Section View of Connection	75
Figure 8-3 – First Option for Spliced Reinforcement Connection	76
Figure 8-4 – Second Option for Spliced Reinforcement Connection.....	77
Figure 8-5 – Pile Bent Cap with Hollow Wall Panel.....	80
Figure 8-6 – Full length Socketed Wall with Bent Cap.....	83
Figure 8-7 – Limited Length Socketed Wall with Bent Cap (other dimensions are same as Figure 8-6)	85
Figure 8-8 – Cross section view showing shear key for abutment module to abutment module connection.....	86

Figure 8-9 – Grouted pocket connection between cap and abutment module for full length socketed wall abutment type.....	88
Figure 8-10 – Horizontal loads acting on abutment caused by earth fill (left) and	91
Figure 8-11 – Forces at the top of the pile (right) shown on a limited length socketed wall type abutment.....	92
Figure 8-12 – Forces in socket region ignoring friction forces on socket	93
Figure 8-13 – Total model and two sub-models for the case friction is included	95
Figure 8-14 – Anticipated reinforcement distribution at the cross section of abutment.....	96
Figure 8-15 – Wall numbers and reinforcement distribution at the cross section of socket region	97
Figure 8-16 – Suggested truss force resisting mechanism in socket region	98
Figure 8-17 – Cross section in plan view of socket region showing the distribution of C_1 and C_2 on walls 1 & 2 respectively.....	99
Figure 8-18 – The cross section view showing how C_1 is carried by reinforcements to transverse walls (wall 3 & 4)	100
Figure 8-19 – Reinforcement in parallel walls (top and bottom) distributed over $l_{emb}/4$ from top and bottom of the socket.....	101
Figure 8-20 – Compression force distribution in socket, the mathematical model and the assumed moment distribution ⁴³	102
Figure 8-21 – Possible punching failure	103
Figure 8-22 – Figure showing the reinforcement that contributes to punching shear strength	105

Figure 8-23 – Longitudinal reinforcement at the corners of the socket cross section	106
Figure 8-24 – Strut and tie forces in socket	107
Figure 8-25 – One node of the strut and tie model showing the angle β	108
Figure 9-1 – Cross section view of abutment section which shows the fixed pile spacing, fixed heights of 3ft or 7ft, and variable overall length	111
Figure 9-2 – Full length socketed wall abutment type with bent cap	112
Figure 9-3 – Limited length socketed wall abutment type with bent cap	113

List of Tables

Table 2-1 – Summary of Bridges Using Precast Substructure Elements and Connection Methods..... 31

Table 3-1 – Various Cross Sectional Alternatives to Reduce the Weight 39

Table 3-2 – Disadvantages of some module to module connection methods..... 43

Table 3-3 – Disadvantages of the eliminated pier cap to column connection methods..... 47

Table 3-4 - Connectors chosen for pier caps supporting superstructures in various span ranges (pier cap to column joint design example can be found in appendices in Pier Cap Design Example)..... 53

Table 7-1 – Construction Schedule Comparison⁴² which compares total time to construct specific elements of the bridge with different techniques (the units are calendar day) 71

Table of Contents

Abstract	i
Acknowledgements	iii
List of Figures	v
List of Tables	x
Chapter 1: Introduction.....	1
1.1 Definition of the Problem.....	1
1.2 Research Objective.....	3
Chapter 2: Literature Review.....	7
2.1 Precast Foundations.....	7
2.2 Precast Abutments.....	9
2.3 Precast Piers	17
2.4 Precast Pier and Pile Caps.....	23
Chapter 3: Procedures Followed (First Phase)	34
3.1 Target Substructure Components	34
3.2 Modularization and Standardization	35
3.3 Identifying the Connection Methods.....	41
3.4 Analysis and Design of Selected Components.....	48
Chapter 4: Alternative Contracting Methods.....	54
4.1 Cost Analysis.....	54

4.2	Alternative Contracting Methods	56
Chapter 5:	Initial Summary	59
Chapter 6:	Application of Pilot Abutments on Baldwin Bridge.....	63
Chapter 7:	Recent Efforts of Other States in Precast Bridge Substructures	68
Chapter 8:	Revised Systems / Improved Bridge Abutments	72
8.1	Bent Cap Connections.....	72
8.1.1	Welded Steel Plate Connection.....	73
8.1.2	Spliced Reinforcement Connection	76
8.1.3	Post – Tensioned Connection.....	78
8.2	Abutments	79
8.2.1	Pile Bent Cap with Hollow Wall Panels.....	79
8.2.2	Full Length Socketed Wall with Bent Cap	81
8.2.3	Limited Length Socketed Wall with Bent Cap.....	84
8.2.4	Connection Methods for Abutment Modules	86
8.2.5	Socket Region Analysis and Design Method.....	89
8.3	Key Items about New Systems.....	108
Chapter 9:	Conclusions and Recommendations	110
Chapter 10:	Appendices	123

Chapter 1: Introduction

1.1 Definition of the Problem

Although cast in place construction has been a conventional method for many years for highway bridge construction, it lacks certain advantages that precast concrete brings to highway construction. Recently urged by the demand from the traveling public and freight transportation, construction duration has become a vital focus in highway construction. Cast in place construction takes a substantial amount of construction time as it requires forming, placing and curing time and additional labor for these. Delays in concrete pouring on site in case of non-cooperating weather may occur in regions like Wisconsin where unpredictable weather is expected. Extended construction durations cause inconvenience especially for bridge replacement projects where road closure periods come into the picture.

Bridge inspections are performed at least once every two years in Wisconsin following the federal guidelines in their bridge inspection and maintenance procedures. Out of 13798 bridges in Wisconsin, 2091 bridges were evaluated to be deficient, 1302 and 798 of which were classified as structurally deficient (deck, superstructure or the substructure is rated under 4 out of 9) and functionally obsolete (bridge geometry does not meet the current standards) respectively according to bridge inspections in 2009.¹ Although, not all deficient bridges require replacement as they are not necessarily unsafe, the numbers are indicators of the potential number of bridge replacement projects that may take place in Wisconsin in the upcoming years.²

From the economical aspects of long detours during bridge replacement construction, need for temporary bridges, and traffic congestion emerge the need for a faster alternate

construction method. On the other hand, concrete has long been used as a construction material and is very familiar to designers, and contractors. The codes and design methods are available based on years of experience and the behavior is well understood. Precast concrete maintains these desired aspects of cast in place concrete and enhances the construction by shortening the project duration.

Accelerated construction, to avoid construction delays and lane closures, is one of the leading reasons for promoting precast construction followed by facilitating construction, improving quality and durability, increasing work zone safety, while minimizing environmental impact and costs.³ Quality control on the site is limited by the site conditions and the facilities on site for cast in place construction. Therefore better quality control can be achieved with the use of precast concrete at the precast plant in combination with high performance innovative materials. With improved quality, better durability may be attained decreasing the long term cost. Shorter durations also lead to shorter exposure times for workers and decreased work zone safety risks. For projects where most of the work is carried out on water or at heights, shorter duration becomes particularly important. The impact of the construction on the public is further decreased due to shorter risk periods associated with traveling vehicles near the construction site.

The effectiveness of precast construction has been recognized in Wisconsin for superstructure construction for many years. Standard precast superstructure unit plans are available and frequently used. Precast technology for bridge substructures, however, has not yet been widely utilized in Wisconsin despite the innovative constructions taken place in the other states. Even though the superstructure replacement is fast, the overall duration of the

construction is controlled by the substructure construction duration since the substructure has to gain strength before the superstructure can be placed. The existing projects in other states or outside the US showed that precast technology is an efficient and competitive means of reducing the substructure construction time. The aim of this research is to identify a system compatible with conditions and current practice in Wisconsin to accelerate the substructure construction for the various purposes mentioned above.

1.2 Research Objective

The goal of this research is to propose an alternate standard system of precast bridge substructures for Wisconsin which can substitute for the conventional cast in place systems when accelerated construction or any of the other benefits noted above are sought. Although bridge characteristics vary for each project, an efficient standard system applicable to the widest range of projects is desired.

There are many advantages related to a standard system as opposed to custom designed systems when precast construction is considered. Standardization allows units of similar geometry to be manufactured and thus the initial investment for the formwork is worthwhile for the precast manufacturers in the long term. The usage of the same formwork for precast elements will reduce the cost of each precast module substantially. Repetitive features of the projects provide familiarity with the system to the contractors, the design engineers and the manufacturers. Furthermore, it is believed that the construction efficiency will develop faster when a standard system is used since the lessons learnt during one project are immediately applicable to others.

In order to be a feasible alternative to the current system of practice, several distinct features of precast construction must be taken into account when developing the standard system. While the precast system shifts most of the work to the manufacturing plant, the planning stage before the construction and manufacturing should be given special importance. Since the precast system will eliminate the most of the time consuming steps of the conventional construction, there is a need for a good planning for further time savings. The steps in conventional cast in place construction such as forming, reinforcement placing, pouring, curing and removing will be eliminated by the new system. The main construction step for the new system will be erection. The cast in place amount for the new systems will not be significant. Therefore, as long as the planning and application of erection process is done in accordance with the proposed techniques, the system is expected to be much faster than the conventional construction.

First, the system should be targeted by the needs in Wisconsin in the planning stage. The conditions that the system requires for this purpose include overall shape and concept familiarity to accommodate existing practice and the types of supported superstructures that are commonly used. Similarity in shape and function should also allow the use of familiar design methods. Yet, the emulation of the existing structures is proved to be inefficient. This is mainly caused by the weight of the emulated module. For that reason, for the second phase of the project lightweight modules have been decided to be developed while trying to keep the number of connections down. While thinking about modularization the simplest connections were tried to be used for the pace the project as well as the cost of those connections. The easier the connection is, the more economical to finish that connection by

less people and less material. Another issue is the tolerance for connections. In this project, the systems are developed giving workable tolerances to connections. Moreover, in this project the effort for each connection is tried to be minimized.

For the manufacturing stage, the geometry of the units or the features they accommodate are constrained to be easily manufactured with non complicated, easy to remove formwork systems which minimize fabrication costs and produce a competitive product.

Other important advantages of precast concrete include the safety and the quality control/assurance that it provides. Since the time for construction will be reduced, the likelihood of accident occurrence for workers will be reduced as well especially for the constructions on certain heights. Furthermore, the quality of the modules manufactured in factory is better than the structures made on site. Since the accuracy of the formworks, quality of the material, effect of better curing conditions and the quality checks by engineers make the modules way better and durable than conventional construction. For that reason, the life cycle of the structure is expected to be longer than the cast in place option.

The restriction on system development for the construction stage covers the constructability of the system including connections and construction tolerances provided in the details, or the speed or practicability of the methods involved in construction.

Another important issue is the overall cost of the precast project and its comparison with the same scale cast in place project. There are no exact cost figures to use therefore; decisions on economical aspects have been based on general ideas and feelings.

This study has been divided into two phases. This thesis encompasses both phases. *Chapter 3 – Chapter 5* explains the first phase of this project (work completed and reported by Okumus). *Chapter 6 – Chapter 9* elaborates on the second phase of work conducted for this thesis.

Chapters in the thesis include the followings. *Chapter 2: Literature Review* gives a literature review conducted to identify the existing examples of precast substructure construction, the advantages and the drawbacks of the systems. *Chapter 3: Procedures Followed* aims to pick the target components for the first phase of this research by evaluation of the substructure components, piles, spread foundations, piers, pier caps, and abutments for suitability for precasting by the need in Wisconsin. *Chapter 4: Alternative Contracting Methods* proposes alternative contracting methods suitable for precast construction, describes the means of cost analysis and decision making processes to promote the use of the system and lists construction steps. *Chapter 5: Initial Summary* summarizes the first phase of this study and shows the outcomes. *Chapter 6: Application of Pilot Abutments on Baldwin Bridges* explains the pilot bridge construction that has used the abutment panels developed in the first phase. *Chapter 7: Efforts of Other States for Precast Bridge Substructures* gives examples of precast bridge substructures from other states obtained after the first phase had been completed. Next, *Chapter 8: Revised System/Improved Bridge Abutments* elaborates on the improved abutment systems and new bent cap connection systems in this second phase. The last chapter, *Chapter 9: Summary* summarizes the research.

Chapter 2: Literature Review

This chapter presents the background information which formed the basis for the research. Several states in the US have taken advantage of precast construction for bridge construction to address problems regarding rapid replacement or construction, durability, aesthetics, and geometrical limitations. In addition, precast concrete bridges have an international use as reported by scanning committees. Although most of the projects were custom designs planned for specific requirements of the projects, their success highlighted the advantages of precast technology for bridge construction. Developing a standard precast substructure system for Wisconsin was promoted by this fact and the focus of the literature study was on identifying the suitability of the existing systems for Wisconsin.

2.1 Precast Foundations

Footings and piles, namely shallow and deep foundations respectively, are investigated. Foundations are used under the abutments or piers and provide the force transfer from these elements to the soil. Precast foundations became the object of attention for water crossing bridges because of the difficulty of construction or quality control of pouring concrete near or in water. Precast concrete would accelerate the construction by eliminating this need. It also lessened the environmental impact of in-place construction on streambeds.

The Epping Bridge in New Hampshire utilized precast spread footings, under precast abutments, connected to the abutments with mechanical splices.⁴ The footing is broken into smaller modules and the unity is provided by female-female shear key joints filled with non-shrink grout. (Figure 2-1) One main concern with any shallow footings is the possibility of

streambed scour in the long term, damaging the stability of the footing. A second concern is that the underlying layer of soil should be level to provide uniform load distribution, which is generally not the case originally found at the site. To overcome this local bearing problem, an additional operation of leveling the soil or the bedrock is necessary. Pouring a concrete or grout layer to further ensure the uniform contact at the interface prior to footing erection is needed. Roughening the bottom surface of precast member is also recommended.⁵



Figure 2-1 – Precast footing module with a shear key and splice detail getting placed on subfooting⁴

Precast concrete piles have been not only commonly used in bridge construction but also for building construction for many years. Since early to mid nineteen fifties thousands of installations took place around the US.⁶ The piles are available in different size and shapes: generally square, orthogonal or circular cross sections. Voided cross sections are also

manufactured to reduce the weight. Better corrosion resistance is a feature of precast piles and another reason why they are preferred over steel piles. In terms of accelerated construction however, Wisconsin practices steel pile driving so frequently that this familiarity leads to efficiency versus uncommon precast piles. For integral abutments with precast concrete piles, crack progression decreasing the vertical load carrying capacity under cyclic loading was reported after lab tests.⁷ On the other hand, adequate performance with integral abutments meeting the deflection criteria was reported with precast piles after a series of tests in undisturbed clay under lateral loading by another reference.⁸

2.2 Precast Abutments

Several examples of precast abutments were identified during the literature review, mostly given as case studies. In almost all cases the abutment body was broken down into small individual pieces for ease in handling, while rare examples of single piece abutments were also available. Due to the inherent design schedule, the abutment seat and a portion of the footing of the Marble Wash Bridge in California were precast as a single piece, but the authors recommend modularizing for ease in handling large pieces for future projects.⁹ For modularizing, several connection alternatives are proposed for future use: transverse prestressing, fingered joints (multiple female-male shear keys) with vertically inserted shear rods grouted in place, or cast in place joints - while promoting the latter. The rest of that abutment was cast in place which was completed after superstructure erection and did not cause delays.



Figure 2-2 - Single piece abutment stem and partial footing⁹

The projects, where smaller modules are utilized for abutment construction, include examples of abutment module to module connection details. The New Hampshire Department of transportation used vertical shear keys to be filled with grout in between abutment modules as the connection detail for the Epping Bridge noting that this detail might be eliminated for future use for walls under 20 ft height. (Figure 2-3) Also the joint opening used as 1 in. originally was recommended to be changed to 1 ½ in.⁴



Figure 2-3 – Vertically separated modules connected with grouted shear keys⁴

Precast modules can also be post-tensioned together laterally or vertically to provide unity to the abutment. The Andover Dam Bridge in Upton Maine utilized lateral post-tensioning to connect the two abutment modules together. (Figure 2-4) The two abutment modules were match-cast against each other, and the joint was secured against leakage by applying epoxy. The tendons in the abutment were grouted after the road was opened to traffic again. The post tensioning is also designed to carry the passive earth pressure expected to develop for integral abutments.¹⁰

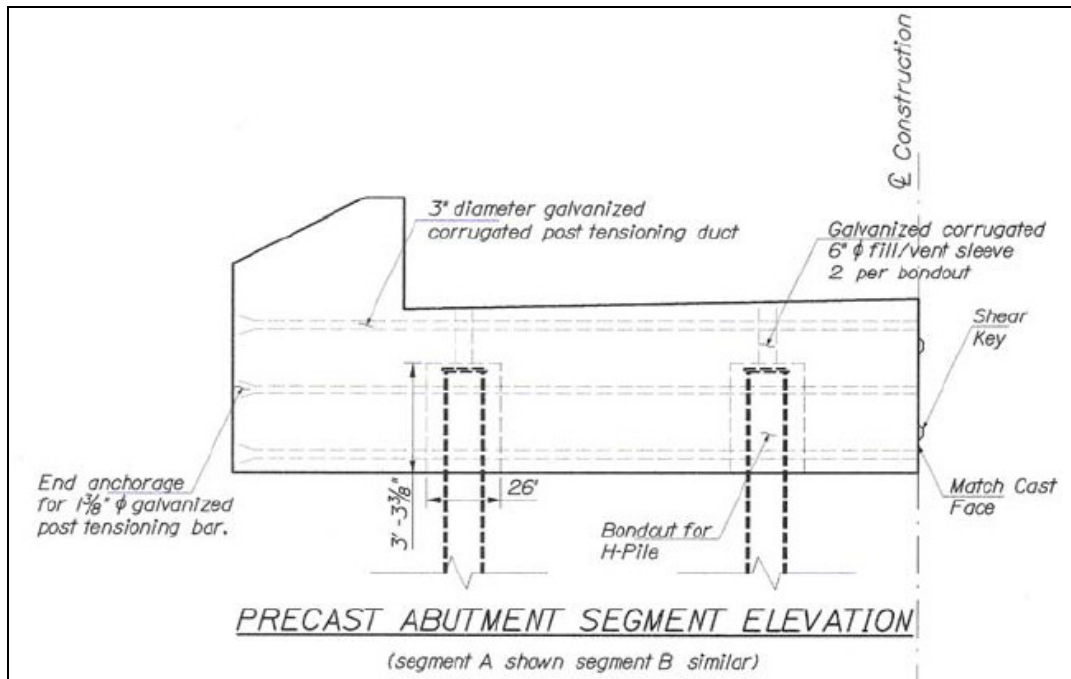

Figure 2-4 – Details of post tensioning to be used for lateral connection of two abutment modules¹⁰

The abutments of the single span Mitchell Gulch Bridge in Colorado represent an example of welded connections of precast modules to each other. Elements of the abutment, the wingwalls and the abutment body wall were attached to each other by welding scab plates to plates embedded in the modules.¹¹ Since no cast in place concrete was involved, the total construction took place on a weekend resulting in a coined name as the “weekend bridge”.



Figure 2-5 – Welding the precast modules together¹¹

Ontario utilized precast abutments in a totally prefabricated bridge over Moose Creek. The abutment modules were connected together by cast in place closure joints between the modules. Reinforcing bars sticking out of the abutment body and closure reinforcement inserted into the joints ensures the integrity of the cast in place connection for the integral abutment.¹²

The connection methods for the abutment units to the adjacent bridge units, superstructure or the foundation were also reviewed. Two connection methods were identified to connect the abutments to piles: connection by embedding the piles into the abutment body, and connection by welding the piles to embedded plates in the abutment body.

Embedded pile connections were used in several projects.^{10 - 15} Although minor differences existed, in all projects the abutment modules were formed such that they have

block outs to be used to accommodate piles. (Figure 2-6) In 2004, the Maine DOT used pile embedded precast abutments for the 65 ft single span Andover Dam Bridge with a steel H pile foundation.¹⁰ For 14 inch deep H pile sections a 6 inch tolerance gap was formed at both sides of the piles to compensate for alignment errors. After the piles were driven they were cut off to the desired length and a leveling plate was attached on top of to form a bearing surface for the abutment body. A steel frame was welded to the piles to form the support for the abutment body for erection. Once the abutment body was placed on steel H piles, the remaining voids in block outs were filled with self consolidated concrete modified with a shrinkage compensating admixture to provide the permanent bond between piles and abutment.



Figure 2-6 – Precast abutment with block-outs, being placed on steel H piles¹⁵

For the Tanglewood Bridge in Texas, 16 inch square prestressed piles are embedded in an abutment body with 3 inch positioning tolerance at both sides.¹³ Tops of the piles were proposed to either be roughened or saw grooved to improve the bond with non shrink cementitious grout as the filling material between piles and abutment. Friction collars on the piles were used to provide the support for the abutment body during erection.

The Mitchell Gulch Bridge abutments have welded connections between the steel piles the steel plates placed in the precast abutment bodies. Sets of steel H piles were driven outside of the existing roadway before the bridge closure to save time. The abutment body then spanned between these sets of piles. Pile to abutment wall connection was assured by welding the piles to the preassembled plates in the abutment wall eliminating the need for grouting.¹¹

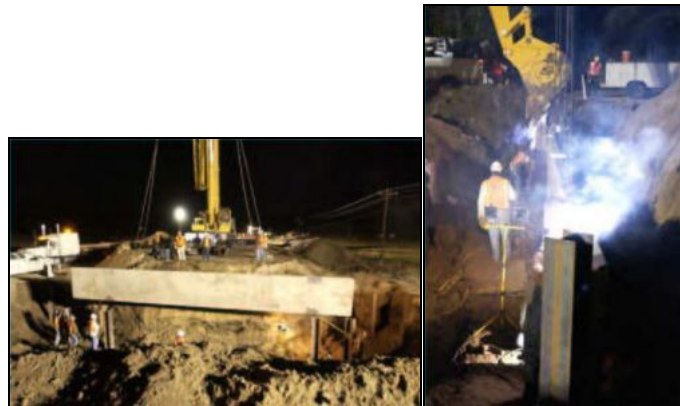

Figure 2-7 – The steel piles in front of the abutment body and the welding process¹⁶

Precast abutments constructed on shallow foundations instead of piles were also observed during the literature review. Vertical post tensioning tendons going through the abutment body were coupled to dowels extended from the cast in place footing in Miller's Run Creek Bridge project in Pennsylvania.¹⁷ Stable geometry of the modules, similar to

vertical double T panels, eliminated temporary supports for the abutment during construction. Post tensioning tendons were placed at the front and back of the abutment for this moment carrying connection. Similar post-tensioning connection to footings was also proposed for another Pennsylvania bridge, on Dillerville Road for abutments as well as the hammerhead piers.¹⁸



Figure 2-8 – Post-tensioning dowels in the footing¹⁷

The Epping Bridge in New Hampshire⁴ was also noted for the grouted splicer detail for footing to abutment connection. This connection detail is used to transfer moment at the connection. The number of NMB grouted splicers used to splice reinforcement from two units was recommended to be reduced for faster construction and better tolerance. On the other hand, pinned connections can also be created by simply embedding the abutment wall in the socket formed in the footing.⁵



Figure 2-9 – Precast abutment pin connected to the footing⁵

2.3 Precast Piers

Throughout the literature review many projects utilizing precast piers, modularized or in single piece are identified. Precast piers are efficiently used since for large multi span projects, repetition of the pier emphasizes the advantages of precast on a cost and time saving basis.

Baldorioty de Castro Avenue Bridges in San Juan, Puerto Rico with spans ranging from 700 to 900 ft, used precast piers, pier caps and superstructure and each bridge was completed in less than 36 hours of construction time in 1992.¹⁹ The precast pier units were composed of a single piece connected to the cast in place footing and the precast hammerhead cap by post-tensioning (Figure 2-10).

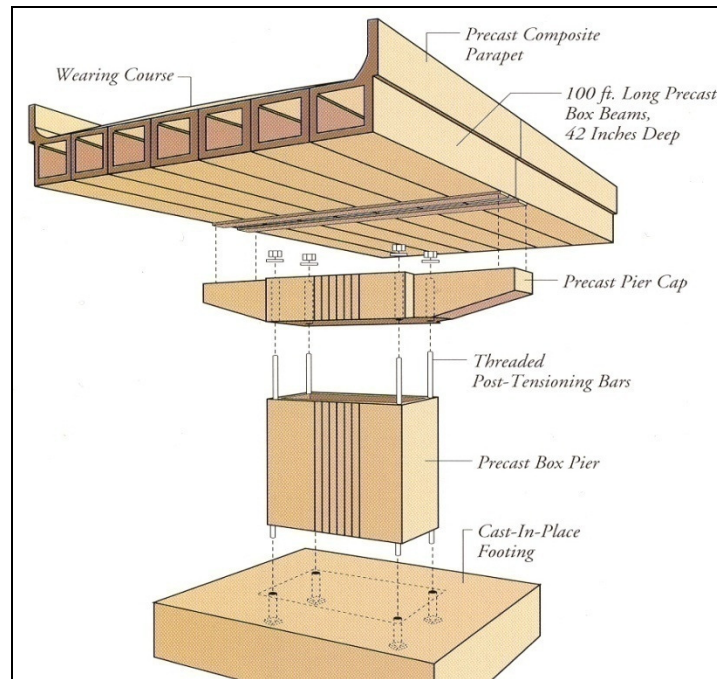

Figure 2-10 – Single piece pier module¹⁶

Ayuntamiento 2000 Bridge in Mexico²⁰ is a six span bridge built on a deep gorge with pier heights ranging from 39 to 138 feet. The tallest piers are composed of 3 segments, connected together by cast in place joints. The piers are designed as hollow units to reduce the weight. The piers have cross sectional dimensions of 6.6 ft by 4.9 ft and a thickness of 6 to 12 in. The upper segments of the piers are manufactured with hammerheads which later form the pier cap when the gap between the piers are closed by cast in place concrete pour and the cap is post-tensioned. (Figure 2-11) Pier segments are connected together and to the foundation by cast in place joints, therefore precast modules are manufactured with protruding reinforcement.



**Figure 2-11 – Precast pier module with an hammerhead extension to form the pier cap
later²⁰**

The Florida Department of Transportation used I shaped piers in two bridge projects: the Mid Bay Bridge and the Edison Bridge in Fort Myers.²¹ The Mid Bay Bridge utilized segmental precast I shaped pier segments connected to each other, to the foundation and the pier cap by post tensioning where strand tendons were looped in the foundations. Connectors are located at each of four sides of the pier I section. (Figure 2-12) The Edison Bridge used mechanical couplers to connect the single piece pier to the cap and to the foundation with the largest pier weighting 89 kips.

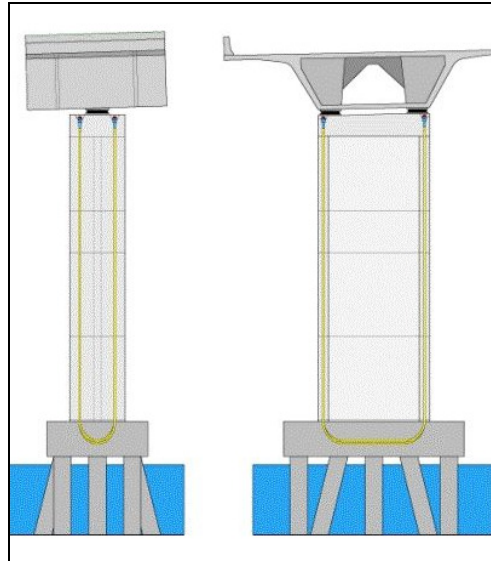

Figure 2-12 – Precast I piers connected to the adjacent elements by post-tensioning²²

A similar method of post-tensioning with a looped tendon strand in the footing was also used to connect the box shaped piers of the Chesapeake and Delaware Canal Bridge with a 750 ft main span length. 463 box pier segments were used with 100 ft of pier completion rate per day. Epoxy grout was applied to the joints before they are vertically post tensioned.²³



Figure 2-13 – Erection of precast box pier section²³

The Texas DOT, over the past years, practiced many examples of precast piers or precast pier/pier cap systems. The bridge on US 183 in Austin (Figure 2-14) and the Louretta Road Overpass in Houston were some examples of segmental pier construction in Texas.^{24, 25} Post tensioning ducts are placed in the hollow pier sections of reduced weight.

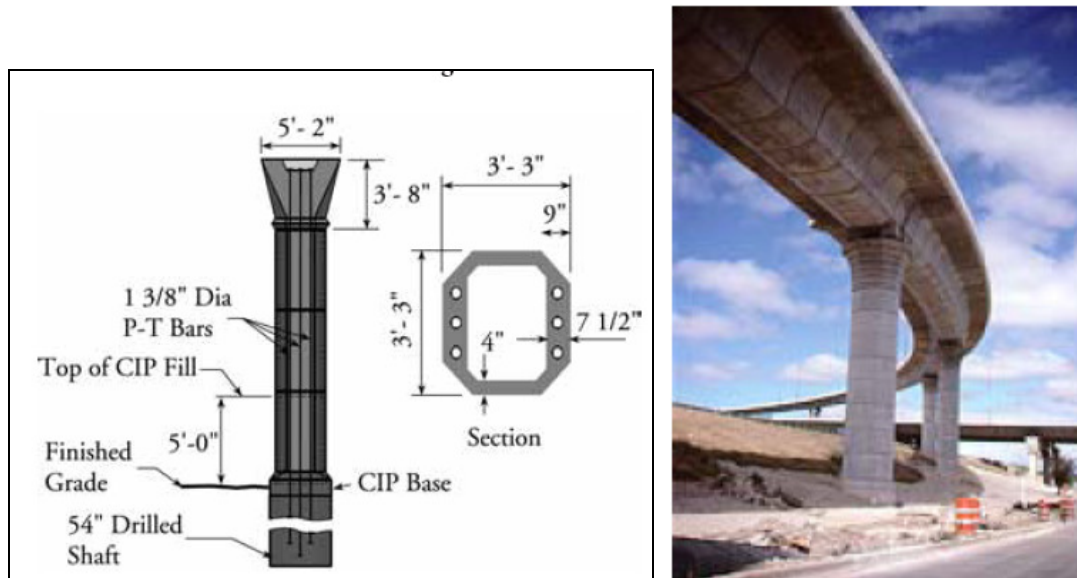

Figure 2-14 – Completed precast segmental pier of US 183 Bridge, Austin^{6,24}

A standardized system was proposed for bridges in Texas by reference²⁴. The proposed system was composed of the pier segments, the template section (serving as a construction aid) and the hollow inverted T pier cap. These elements can be combined in different ways to fulfill the requirements of different projects and geometries. The pier segments are planned to be match cast to eliminate any construction misalignment problems and epoxied to ensure the connection. Post tensioning was proposed to connect the pieces. In addition to the template segment, adjustable supports were also used as geometry control joints. Several column cross sections were presented taking the aesthetics into account.

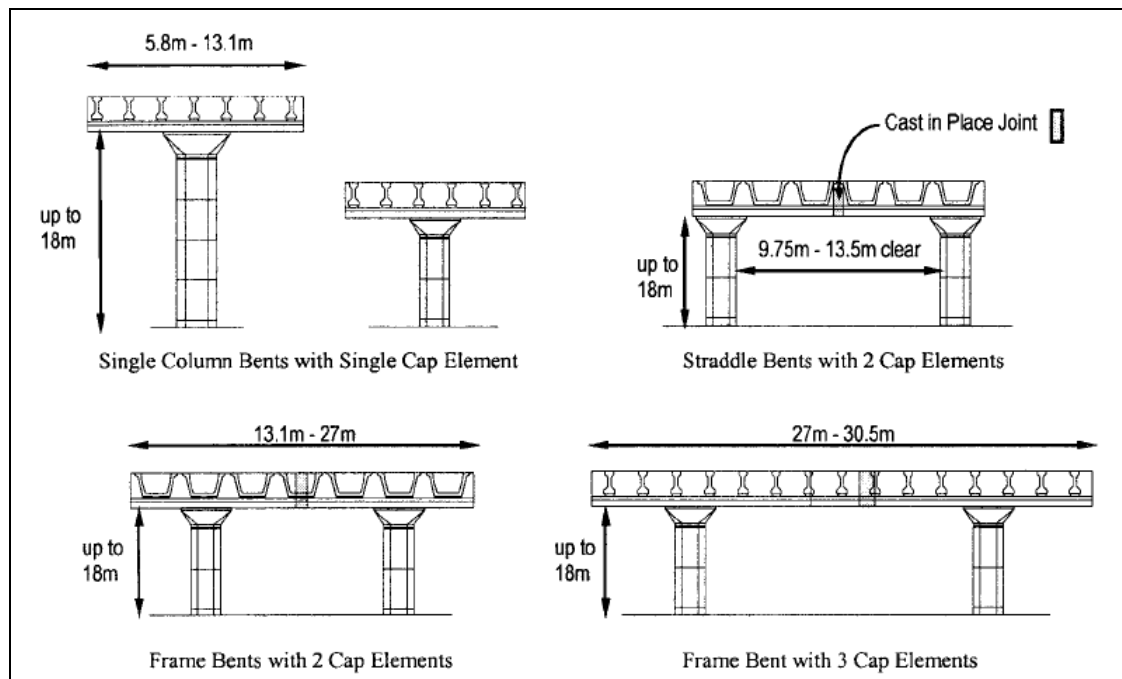

Figure 2-15 – Several pier frame configurations using the system proposed²⁶

2.4 Precast Pier and Pile Caps

Precast pier or pile caps have been used for rapid construction accommodating single or multi columns in numerous projects. More research and testing results are available on precast piers than most other precast substructure elements and will be summarized here.

Since pier caps are relatively large, reducing the weight is a consideration. Modularized precast pile cap use is demonstrated in a rural two lane timber bridge replacement project in St. John's County, Florida.²⁷ Based on the request by the contractor, the pile caps were manufactured in two pieces for handling purposes. Each pile bent had six HP 14x73 piles with 92 tons of capacity each. The pile cap modules were connected together by a cast in place splice. The piles are connected to the cap by embedding the piles in the

voids provided at each location. Non shrink grout was pumped through 4 in. sleeves from the top of the cap to fill the extra voids.

Partially precast bent caps were also used, reducing the weight and emulating the monolithic behavior by the use of cast in place connections. The San Mateo-Hayward Bridge in California was in a high seismic region and monolithic behavior was desired.²⁸ The remaining reinforcement which is not preassembled was placed after the precast pile cap shell had been erected. The superstructure was made integral with the substructure by casting the rest of the cap in place. A 2.5 ft deep precast portion (out of 7 ft deep total cap) of the caps provided a ledge for the girders for construction and the holes accommodated the reinforcement coming from the three 42 in. diameter precast concrete hollow piles. The project used over 275 pile cap shells.



Figure 2-16 – Precast concrete cap shell shown with pile reinforcement and the girders in place, ready for concrete casting in the center region²⁸

A research project conducted by the University of Texas, Austin, proposed several column to cap connection details.²⁹ Four connection details were developed: grout pockets, grouted vertical ducts, bolted connections, and grout-sleeve couplers. The research reports the connection and full scale test results and gives the design guidelines for the connections. U shaped dowels, headed, straight or hooked bars were considered as connector reinforcement alternatives.

Numerous precast pier cap constructions took place in Texas prior to or following this research.^{25, 30} The Red Fish Bay project in 1994 connected the precast rectangular piles by placing U shaped dowels in the pockets provided in the precast cap. The pockets are full depth and grouted from the top of the cap after the cap was in place. (Figure 2-17) The precast rectangular piles had four 1½” diameter corrugated ducts. After driving piles dowels have been placed into ducts in piles and then precast cap has been put in place sliding over dowels. The Lake Ray Hubbard Bridge in Rockwall County in Texas was one of the applications of grouted duct connections. As specified for this system, the reinforcement from the column was extended into multiple corrugated stay in place ducts in the cap. The connection was secured by grouting the ducts. (Figure 2-18) Similarly the Lake Belton Bridge in Bell County in Texas over SH 66 constructed in 2004, had precast hammerhead pier caps connected to the column unit by a grouted duct connection. Mock up tests were conducted by the contractor to ensure the effectiveness of the connection and detect possible problems before the construction. The Pierce Elevated Freeway replacement project in Downtown Houston used bolted column to cap connections in 1997. In a similar way, the US 290 Ramp G Project used post tensioning bars for the precast straddle bents and the

connection was grouted. The road closure time was reduced from 41 days to 6 hours with the use of precast bents. In addition to these, a reference²⁶ proposes a standard system for bridge substructures to be used with standard bridges with post tensioned cap to column connections. A hollow inverted T section was developed to reduce the weight and to improve the visual impact.



Figure 2-17 – Precast pile cap with pockets visible ready to accommodate the connectors³⁰



Figure 2-18 – Dowels protruding from the columns are inserted in the ducts in the cap³⁰

Bridges with similar connection details to the ones constructed by Texas DOT were practiced by other states as well. The guideway structure transports visitors from an underground parking structure to the new J. Paul Getty Museum near Los Angeles, California.³¹ The guideway substructure is composed of cast in place columns and precast hammerhead pier caps. A 180 ton capacity crane was employed for most of the erection work. The reinforcing bars from the columns were inserted into the sleeves in the cap and the sleeves were grouted to provide the connection between the cap and the column (Figure 2-19).



Figure 2-19 – Precast cross head with sleeves³¹

The two span Mountain Valley Road Bridge over I-40, in New Mexico used modularized precast pier caps over precast piers to provide a 52 ft wide superstructure cap.³² The substructure units, including the cast in place components below the pier cap, were constructed before the demolition of the existing bridge. Since a moment resisting connection was desired between the piers and the cap, vertical post tensioning was used (Figure 2-20). 1 ½ in diameter bars were anchored in the columns and tensioned when each piece of the cap was in place. The ducts and the layer between the cap and the columns were grouted. The erection of a precast pier was completed in 1 day, minimizing the road closure time. The Dillerville Road project over Amtrak Road in Pennsylvania also utilized two precast hammerhead pier caps post-tensioned to the pier and to the foundation.¹⁸

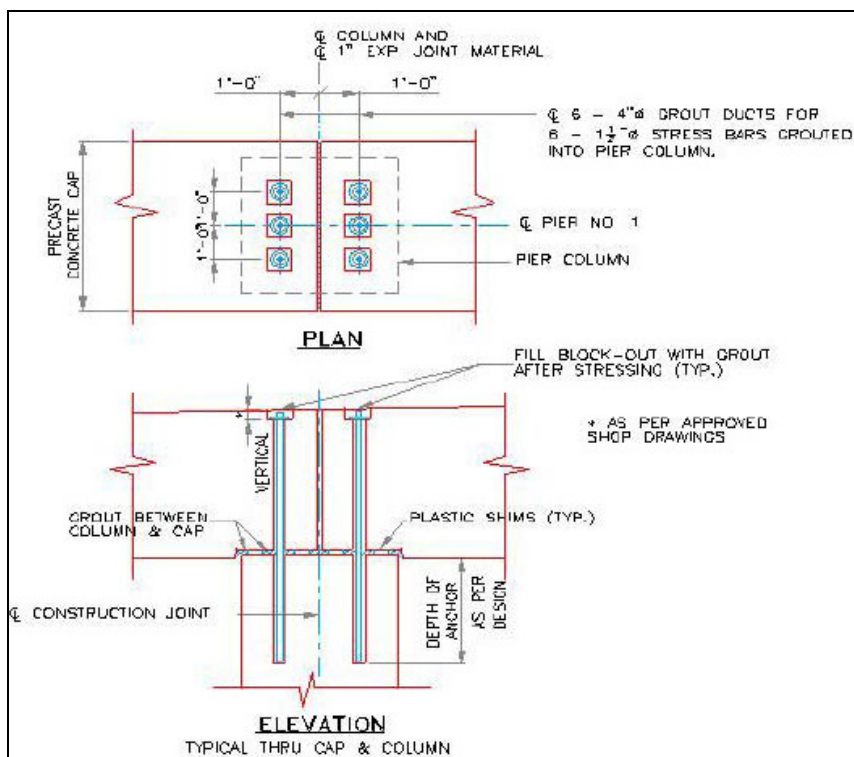

Figure 2-20 – Post tensioned cap to column connection detail³²

The US 90 Bridge over Bay St. Luis had to be reconstructed after the Hurricane Katrina.³³ To speed up the construction precast pile caps was utilized. The 5 ft wide 4.5 ft deep cap beam was manufactured in two pieces and connected together by a cast in place joint. The cap to pile connection was performed in the following way: the pile caps used single trapezoidal shape block outs at each pile location to enclose the connector reinforcement running from the piles to the cap. The circular void in the rectangular precast prestressed piles was plugged near the top to place the connection reinforcement and to allow grouting. Unfortunately the estimated pile tolerance of 6 in. was not enough for the construction and caused the precast cap beam to be redesigned or some caps to be replaced by cast-in-place caps.

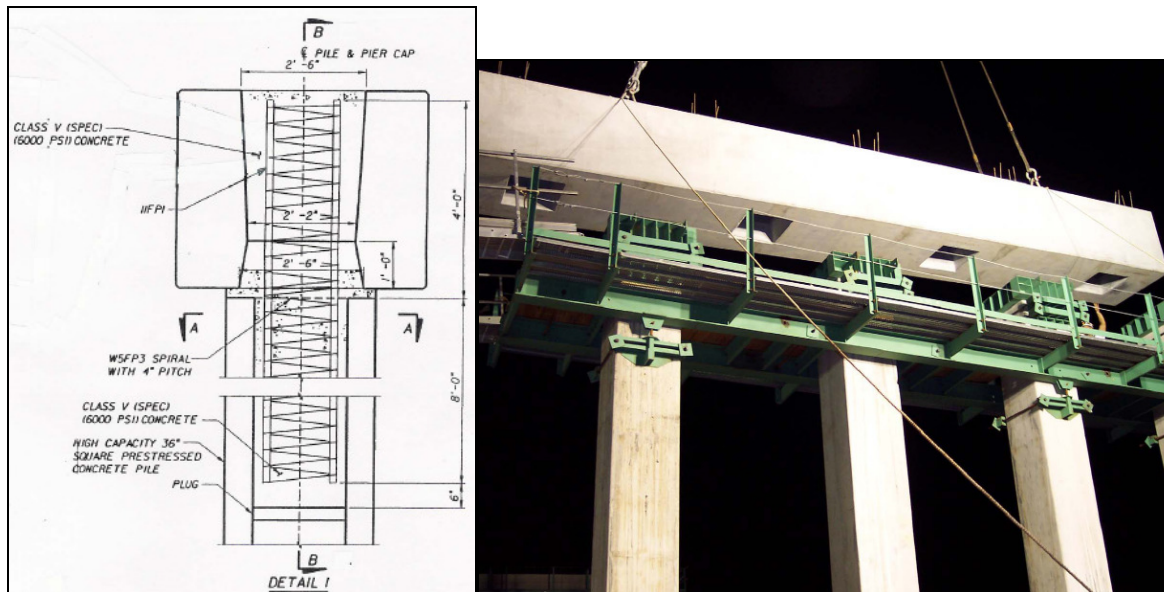

Figure 2-21 – Cross sectional view (left) and erection (right) of pile to pile cap connection³⁴

The Florida Department of transportation uses mechanical splicers for column to cap connections as a standard detail after constructing bridges with this method including the Edison Bridge in Fort Myers.³⁵ 70 piers were created using this technique. The columns were H shaped with 12 in leg thickness accommodating 2 #14 bars at each leg. The U shaped cap was connected to the columns by means of mechanical splicers grouted afterwards. Even though the tolerances expected were very small, the construction was accomplished and full moment connections were provided.

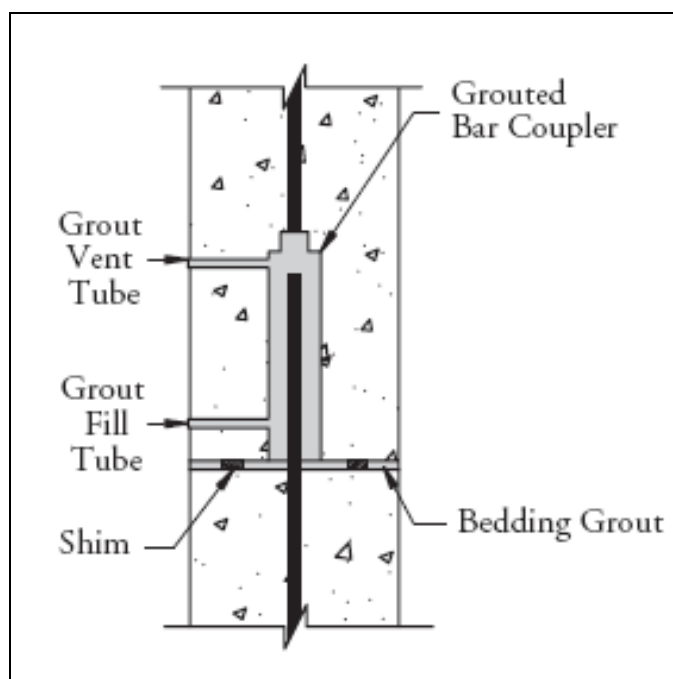

Figure 2-22 – Splice Sleeve Detail⁶

Some of the bridges given as examples above are summarized in the following table together with the precast elements and the connection methods they utilized (Table 2-1). Earthquake resistant precast concrete connections started to gain importance also. Earthquake resistant beam column connection has been developed and another research is currently being completed at the University of Washington on earthquake resistant column to foundation connections with mechanical splices.^{48, 49}

Table 2-1 – Summary of Bridges Using Precast Substructure Elements and Connection Methods

Bridge	Location	Precast Element	Connection Type
Epping Bridge	New Hampshire	Footing, abutment	Shear key, mechanical splices

Marble Wash Bridge	California	Abutment	
Andover Dam Bridge	Maine	Abutment	Post tensioning, grouted pile pockets
Mitchell gulch Bridge	Colorado	Abutment	Welding
Moose Creek Bridge	Ontario, Canada	Abutment	Cast in place joints
Tanglewood Bridge	Texas	Abutment	Grouted pile pockets
Miller's Run Creek Bridge	Pennsylvania	Abutment	Post tensioning
Baldorioty de Castro Avenue Bridge	San Juan, Puerto Rico	Pier, pier cap	Post tensioning
Ayuntamiento Bridge	Mexico	Pier	Cats in place joints
Mid Bay Bridge	Florida	Pier	Post tensioning
Edison Bridge	Florida	Pier, pier cap	Mechanical splices
Chesapeake and Delaware Canal Bridge	Delaware	Pier	Post tensioning
US 183 Bridge, Austin	Texas	Pier	Post tensioning
Louretta Road Overpass, Houston	Texas	Pier	Post tensioning
St. John's County	Florida	Pier cap	Cast in place joint, grouted pile pockets
San-Mateo Hayward Bridge	California	Pier cap shell	Cast in place joint

Red Fish Bay	Texas	Pile cap	Grouted pockets
Lake Ray Hubbard Bridge	Texas	Pier cap	Grouted duct
Lake Belton Bridge	Texas	Pier cap	Grouted duct
Pierce Elevated Freeway	Texas	Pier cap	Bolted connection
US290 Ramp G Project	Texas	Bent cap	Post tensioning
Guideway structure of J. Paul Getty Museum	California	Pier cap	Grouted sleeves
Mountain Valley Road Bridge	New Mexico	Pier cap	Post tensioning
Dillerville Road project over Amtrak Road	Pennsylvania	Pier cap	Post tensioning
-	University of Washington	Pier, foundation	Column to foundation connection with mechanical splices ⁴⁸ and column to beam connection ⁴⁹

Chapter 3: Procedures Followed (First Phase)

3.1 Target Substructure Components

The components included in the substructures group are the foundation, columns, pier caps, and abutments. Based on the frequency of use of these component, need for improvement to current cast-in-place construction, and suitability for precasting, target substructure elements were chosen.

The first down selection was on the foundation type. Deep foundations compose the majority of the bridge foundations in Wisconsin. Therefore, the foundation type to be used with the precast substructures was determined to be pile foundations. Steel HP pile sections HP 10 x 42 and HP 12 x 53, which compose the most frequently used pile types together with cast in place concrete piles, were selected to be the foundation for standard components. Steel HP piles are advantageous for the speed of driving, eliminating cast-in-place concrete, familiarity of practice, and ease in splicing or cutting to adjust the elevations at the pile top.

The second selection was to determine the target precast abutment geometry and function. WisDOT has several standard abutment types suitable for different bridge projects: sill, semi retaining, and pile encased abutments. The frequency of use in the last years of these types based on the data given by the Wisconsin Highway Information System³⁶ showed that sill and pile encased abutments were used for most of the bridges (Figure 3-1). The common features of these two abutments were the pile foundation encased in the abutment body eliminating the need for a pile cap, no inclined surfaces, no battered piles or no backwall for superstructure. These abutment types have heights ranging from 5 to 10 ft. A standard precast abutment was desired having these characteristics based on the frequent use.

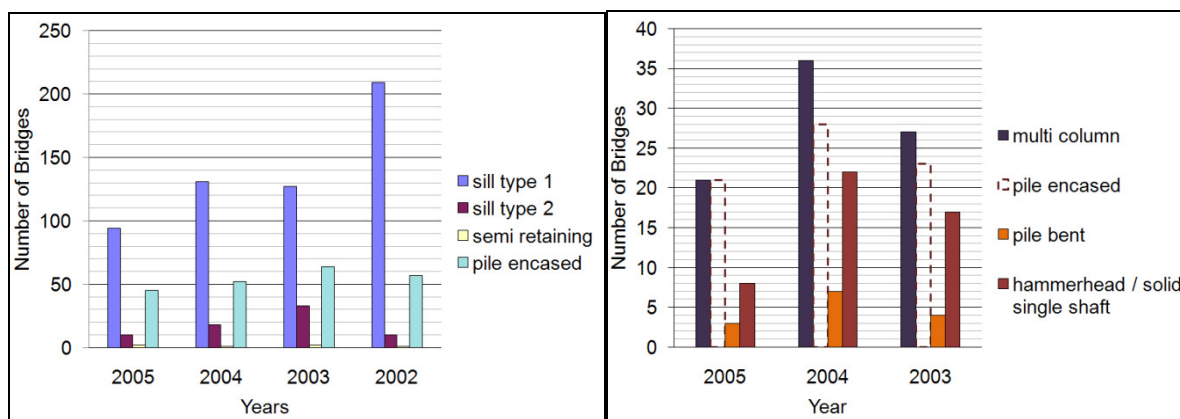

**Figure 3-1 – Frequency of use of various abutment and pier types
(left = abutments, right = pier caps)**

Precasting the pier caps has a significant advantage of limiting the time for tasks to be performed at heights and improves work zone safety.

For pier caps, the analysis of historical frequency of use highlighted multi column piers over single column piers. (Figure 3-1) The pier cap for multi column piers (and also pile bents) with a rectangular geometry was picked as part of the standard precast substructure system. Pier columns on the other hand were assumed to be cast-in-place for this system, based on WisDOT preference, due to relatively non complicated forming and contractor familiarity.

3.2 Modularization and Standardization

A component weight limit of 40,000lbs was selected as a guide to avoid any special permitting requirements during transportation. This weight also falls into the capacity range of cranes used in erection of bridges with precast girder superstructures. Due to the dimensions of the components dictated by the bridge geometry, the weight of the abutment

and pier cap may become excessive and surpass the 40,000lb target if a single precast piece is used. Therefore modularization was considered for handling and erection purposes.

Precast Abutments:

Abutments could be modularized by using either vertical or horizontal joints between pieces. The configuration where adjacent abutment modules were separated with a vertical joint allows for simpler connection details as opposed to using horizontal joints where the joints have to transfer considerable moment and shear from lateral backfill loading down to the piles.

A constraint of a minimum of two piles for each abutment module is adopted to restrain vertical movement of abutment modules and make them essentially self-supporting and stable. The connections between adjacent modules would not have to transfer loads. With settlement very limited due to the pile foundation, the abutment modules are considered to be non continuous members separated by vertical joints under vertical loading from superstructure. Each module is able to resist the vertical and lateral loads applied. The force transfer at the joint is minimized eliminating the need for complicated connections. Under the lateral earth pressure, the modules are anticipated to deflect similarly minimizing loads at the vertical joint.

Initial standard abutment sections with heights of 3¼ ft, 5 ft, and 10 ft by 38in. thick were selected, having joints between modules in the vertical direction, leaving the length of the modules to be a variable dependent on the project needs. (Figure 3-2) It is assumed that precasters would purchase standard forms in the three height configurations with adjustable side forms to allow variable length dimensions. The 38in. thickness was defined by WisDOT

as the necessary amount to allow for pile embeds and to provide a paving notch for the bridge approach slabs.

The total abutment length for any specific project should be divided into equal length modules without exceeding the 40kip per module weight limit, creating a set of identical modules for each project. When abutment heights other than the three standard sizes are needed, they can be obtained by using one of the standards and burying or lowering the bottom of the abutment to achieve the desired elevation. The modules should have a flat top surface to allow repetitive use of standard forms. The roadway crown or variable girder elevations can be created by using precast beam pedestals that are dowelled or keyed into the abutment. With flat slab bridges the abutment top would be flat and crown achieved in variable thickness of the cast-in-place slab.

The minimum pile embedment length is determined to be 2 ft which is a reasonable depth for easy forming and avoiding problems in abutment erection due to pile misalignment. Piles that are non-vertical after driving should still be able to slide into a short 2 ft pocket in the abutment. Special tolerances on pile driving should be defined in the project contract provisions. For the 10 ft high abutment, which is under larger earth pressure, a longer pile embedment length, up to 8 ft, could be employed where abutment tipping is a concern.

The shallowest abutment depth (3¼ ft) was determined based on the minimum depth of concrete over the pile which prevents punching of piles through the concrete body when the piles are vertically loaded to their capacity.

This shallowest section may be used alone with shallow embankments, or could also be used as a cap beam with thinner 8in. wall panels attached behind the piles, a system where

the cap transfers the superstructure load to the piles and the wall panels span between the piles retaining the earth and resisting the lateral backfill pressure. This system is frequently used in railway bridges and may be advantageous due to the lighter nature of the shallowest section and the walls. A schematic of this alternate use for the shallow section is shown in Figure 3-2 (left) with the other normal abutment applications.

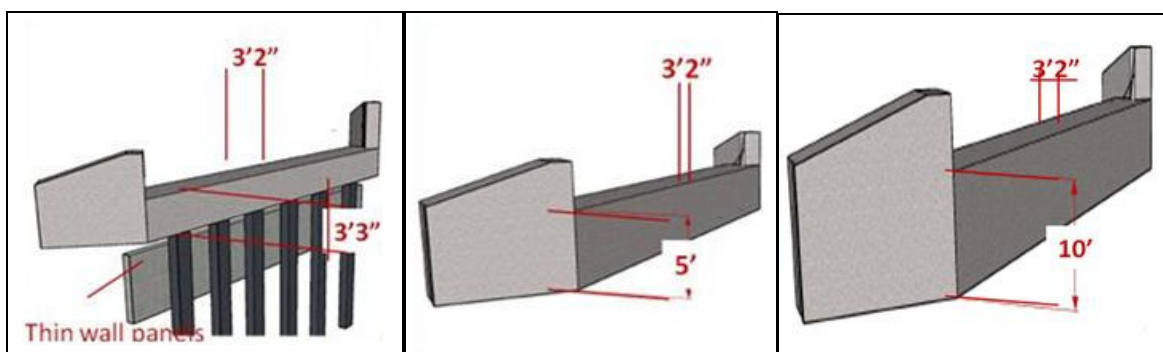







Figure 3-2 – Summary of the Standard Abutment Module Dimensions

Typical current cast in place wingwalls are similar in shape to abutments, but generally higher to retain the earth at the top of the superstructure level. The upper portion of the wingwalls is difficult to standardize due to the variability in geometry of the sloped section for different projects. Use of the standard rectangular precast abutment modules, in combination with a cast in place upper portion, is suggested for the wingwalls (Figure 3-6). Wingwalls that are not parallel with the front wall will still cause standardization problems, however, because of the unique joint between the wingwall and the front wall. This will be discussed later in developing joint systems.

Precast Pier Caps:

For a standard pier cap of 3.5 ft x 3.5 ft rectangular cross section, the 40,000lb weight target would impose a maximum length of 22 ft. Given that a typical bridge of three lanes is 42 ft wide; it appeared that a lighter weight section was needed or a multi piece cap beam might be required. Cross sections with reduced concrete area were reviewed. Various cross sections and the approximate ratio of their weight to the solid rectangular section's weight are shown below. The solid rectangular section is familiar to contractors and designers, easy to form and manufacture without complicated reinforcement details. The inverted U section allows easy inspection and easy forming unlike the box sections. Therefore the inverted U section was chosen as a candidate section in addition to the solid rectangular section.

Table 3-1 – Various Cross Sectional Alternatives to Reduce the Weight

Cross Section	Approximate Weight / solid rectangular
 Solid Rectangular	100 %
 Hollow Rectangular	75 %
 Solid Inverted T	95%
 Hollow Inverted T²⁴	80%
 Inverted U³⁵	75%
 Tapered Rectangle	90%

Modularizing was also examined for the pier caps. Several possible joint configurations and the load transfer and temporary supports they would necessitate were

studied. (Figure 3-3) For all the combinations, modularizing the pier cap necessitates major load transferring connection details and temporary supports prior to completing a connection.

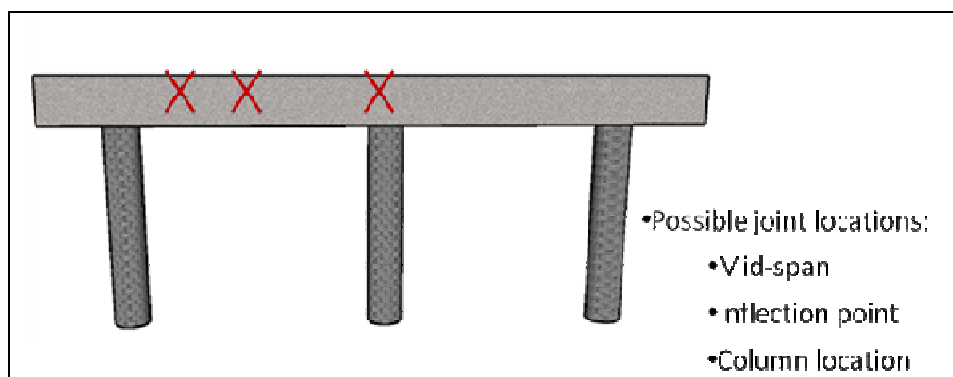

Figure 3-3 – Possible joint locations marked for a modularized precast pier cap

Considering that multi column piers are used mostly with girder type superstructures, it is reasonable to assume that utilization of cranes that are needed with larger capacity for lifting girders is possible. In placing a pier cap the crane will not likely need as long a reach as in placing girders. Therefore the heaviest precast pier cap that is still constructible may be 80,000lb or more. A 130ft long 54W girder would weigh 108,000lb. Equipment with 80,000lb capacity is expected to be used for average length girders, and 40-50 ft long U-shaped caps weighing 70,000lb could then be shipped and lifted as single piece units within this limit. A single piece pier cap unit which can cover bridges of 40-50 ft wide is preferred over multiple pieces to eliminate connections. As noted earlier for form repetitive use, it is preferred that the caps are built with a flat top surface and beam steps be obtained by using variable height precast pedestals connected to the top of the cap.

3.3 Identifying the Connection Methods

The connection details compiled for this project were grouped into two types according to the use, module to module connections, and module to adjacent member connections. The first group covers the connection details for abutment module to module joints, while the second group of module to adjacent member connections would be used for abutment module to pile and pier cap to column or pile connections. The connection methods most suitable for a standard system were selected, aiming at simple to construct details with reasonable tolerances, and using the common construction methods familiar to contractors.

Module to Module Connections

Shear keys, lateral post-tensioning, splice sleeve connections, welded connections, bolted connections, and cast in place connections are all methods currently used to connect precast concrete components as illustrated in Figure 3-4.



Figure 3-4 – Abutment module to module connection methods: Spliced Sleeves (top left), Post tensioning³⁷ (top right), Cast in place closure joints¹² (bottom left), Welding¹¹ (bottom right)

Abutment modules with vertical joints eliminate the need for major load transfer through the joint and allow for simpler connections. All connection methods were evaluated based on whether they meet the service demand, and whether they are easy to construct without requiring special equipment. Since each module is already supported on two piles, there is virtually no load demand on the joint. Instead the joint needs to maintain an attractive appearance even if differential settlement occurs or unexpected differential lateral backfill pressured develop.

Shear key connectors were picked as a high priority connection method between abutment modules as the load transfer need is minimal and they are simple to complete. If differential settlement occurred, the joint could slip vertically with little sign of distress. If uneven backfill pressures develop, the keys are very effective in transferring out of plane shear from a module to an adjacent one without visible differential movement. Shear key abutment module connections were successfully used for the Epping Bridge in NH. (Figure 3-5) Other options are less desirable due to the disadvantages summarized in Table 3-2.



Figure 3-5 – Example shear key vertical abutment to abutment connection⁴

Table 3-2 – Disadvantages of some module to module connection methods

Connection Type	Disadvantages
Lateral post tensioning	Requires special equipment; Unfamiliar to local contractors and may require separate subcontractors; Not presently preferred by the WisDOT; Load transfer capacity provided is not needed.
Splice sleeve connection	Tight tolerances required; Protruding bars from the forms make production difficult or multiple expensive sleeves in each module.

Welded plates	Requires on site quality control; Requires a certified welder on site; Requires welding equipment; Not currently practiced by WisDOT; Stainless steel plates and welding needed for corrosion resistance.
Bolted connection	May demand tight tolerances, or if slotted plates used the deformation control is limited; Requires galvanized hardware.
Cast in place connection	Requires protruding bars from the precast elements which makes production difficult, or requires multiple expensive splice sleeves; Requires onsite forming and reinforcement placement; Requires onsite concrete placement and curing time.

Since the same modules are proposed for use in wingwalls and abutments both systems will be joined with shear keys. This will work well if the wingwalls are parallel to the abutment front wall. If the wingwalls are set at angle to the front wall, as in Figure 3-6, unacceptable conditions may develop. If the lateral backfill pressures create outward deformation of the walls, then the joint between the corner panels will open up because the wingwall panel and abutment front wall panels will move in different directions. A tension tie is needed between the corner modules to prevent the joint opening.

This tie can be achieved as shown in Figure 3-6. Vertical dowels are drilled into the tops of both corner modules and then reinforcing in the top cast-in-place material provides the tension tie. This tie system does not need to be placed before construction of the superstructure begins – thus not slowing the construction process. The slower to accomplish cast in place portion of the walls can be completed as convenient, but before backfilling.

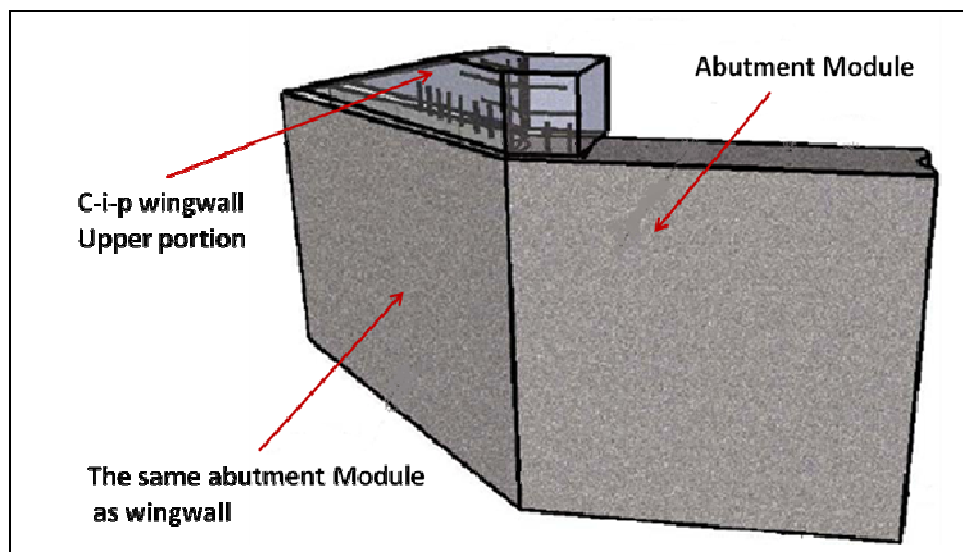

Figure 3-6 – Wingwall as a combination of the precast abutment module at the bottom and the cast in place portion at the top which also provides the connection

Module to Adjacent Member: Pile to Abutment Connections

The two common connection methods for the pile to the abutment module are embedment of piles in the abutment body or welding the piles to the abutment body. (Figure 3-7) The welded connections, with plates embedded in the precast body welded to the steel piles at multiple locations, are not preferred by WisDOT due to the same disadvantages noted previously for welded connections.

The embedded pile connection, which is used in most of the existing Wisconsin bridge projects with cast in place abutments and piles, is the focus for this project. This system requires the abutment modules to be formed with block outs to accommodate the piles. The block outs in the precast abutments must be oversized to provide tolerance for misalignment of the piles during pile driving. A reasonable block out size would be 22in. x 22in. in x 2 ft. minimum length. The standard piles are 10in. or 12in. H piles. A 22in.

blockout provides 5-6in. of tolerance on each side of the pile. After the pile is embedded, the blockout is filled with grout through ports from the side of the abutment, or concrete is placed from above if the blockout extends full height. The inner surface of the block outs should be roughened, at least in the region above the pile, for better bond.



Figure 3-7 – Pile to Abutment Connection methods: Embedded connection¹⁵ (left), Welded connection¹¹ (right)

Column to Pier Cap Connections:

The main types of connections for the pier cap to a column include cast in place connections, bars in splice sleeves, bolted connections, and post tensioning. (Figure 3-8) Cast in place and grouted connections are composed of concreted or grouted block outs, grouted pocket connections, and grouted duct connections²⁹ all of which embed the connectors coming from the columns into the block outs. Welding could be used, but is not examined here due to WisDOT preferences.

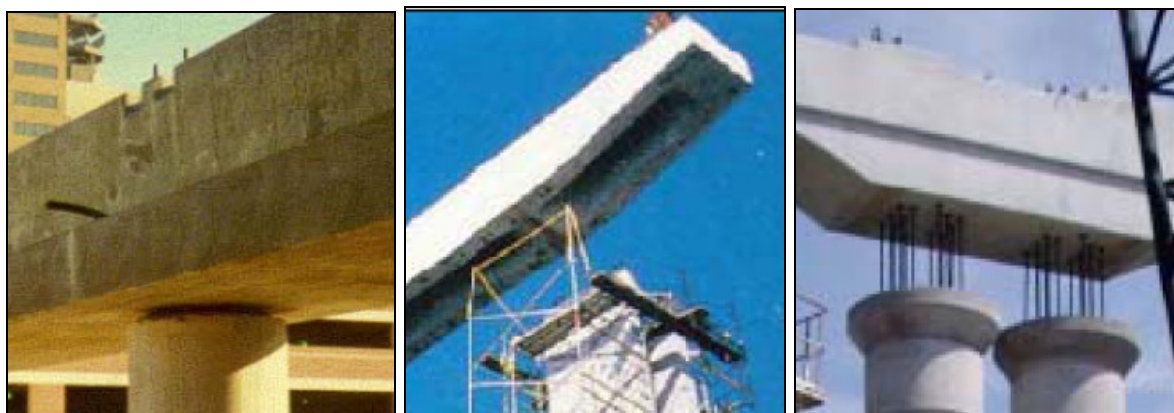

Figure 3-8 – Pier Cap to Column connections: Bolted connection³⁸ (left), connection by splice sleeves³⁵ (middle), grouted duct connection³⁰ (right)

Examining these connections, grouted pockets were selected as the preferred method due to their simplicity and wide tolerance as compared with other methods in Table 3.3-2. It is important that any pockets in the cap create minimal interference with the cap reinforcement. An example of a grouted pocket connection is shown in the figure from the construction of the Red Fish Bay Project, Texas. (Figure 3-9)

Table 3-3 – Disadvantages of the eliminated pier cap to column connection methods

Connection Type	Disadvantages
Grouted block outs	A large blockout may interfere with the cap reinforcement; Requires more grouting or concreting to fill.
Grouted ducts	Tight tolerances; Require pumped grout.
Splice sleeve	Tight tolerances; Sleeves may be expensive and require pumped grout.
Bolted / Post tensioned	Tight tolerances for bolted connections; Special equipment and contractor for post tensioning; Not preferred by the WisDOT.



Figure 3-9 – Grouted Pocket Connection with Pier Partially Embedded in Cap³⁰

3.4 Analysis and Design of Selected Components

The design of precast modules and cast in place components are similar. Due to the changes made in the structure geometries, the need for standardization, the need for modularization with precast joints, and changes to develop a more efficient system suggested that the precast pieces be specially designed. The preliminary designs are also tools to check and show the applicability of the new concepts to real structures.

Design of Approach for Precast Abutments (the detailed design calculations can be found in appendices named as “Preliminary Abutment Design Example”):

Abutments are under the vertical loads from the superstructure and lateral loads from the retained earth. Vertical loads generally depend on the span of the bridge. The horizontal earth load is a function of the abutment height.

Design calculations for the abutment modules were repeated for three standard heights. The abutment was assumed to act as a cantilever beam fixed at the bottom to allow early backfilling. Once the superstructure is in place it may act as a diaphragm providing an extra support at the top of the abutment. The resultant back-face reinforcement to resist moments from lateral soil pressure was not governing for any of the abutment heights.

The vertical load from superstructure would vary depending on the span length and superstructure construction. In order for the standard abutment designs to cover most bridges of interest, the abutment modules were designed to resist whatever superstructure load that could cause the piles to reach their capacity. A standard average pile capacity of 100kips each was assumed. Since each module has two embedded piles, the total vertical load on a module was assumed to be 200kips. A situation where the piles were assumed to reach their ultimate strength capacity was also studied but was not adopted as a design load since it would result in a very conservative abutment design.

This design basis will cover most of the average bridges in Wisconsin. The maximum WisDOT allowed spacing of piles, 8 ft, was used to create the most unfavorable case. Even with the maximum pile spacing, the span lengths were small compared to the abutment depths. Since the abutment acts as a deep beam, a strut and tie analysis was preferred over the common bending theory approach. Several truss models were formed and reinforcement was proportioned to carry the reactions formed at the tension ties and the compression struts for abutments of the three standard heights, 3¼ ft, 5 ft, and 10 ft.

Design Approach for Precast Pier Caps (the detailed design calculations can be found in appendices as named "Preliminary Pier Cap Design Example"):

Standard pier cap analysis and designs were performed for 4 ranges of girder bridge spans taken in 20 ft increments, between 50 ft and 130 ft. For each analysis, a bridge with the longest span of that range was used. Pier frames were analyzed as having both rigid and pinned joints between the piers and the cap - to create the maximum bending effects at the pier and in the span respectively. Those forces were then assumed as the lower and upper bounds for the cap design moments. The superstructure reactions on the cap were calculated for a 42 ft wide bridge with 3 columns 36 ft high at each pier.

The loads applied on the pier frame included: dead load of the girders, the deck and the wearing surface, live load including the truck and lane loads creating the worst reactions, loads due to vehicle braking, wind load in transverse and longitudinal directions of the bridge acting on superstructure, substructure and vehicles, and loads due to temperature changes. The reactions due to lateral loading in the transverse direction of the bridge dominated relative to loading in the longitudinal direction of the bridge.

Due to the pockets at the cap connection region to the columns, the availability of sufficient room for the longitudinal pier cap reinforcement needed to be checked. Pier caps, both solid and inverted U sections designed with mild reinforcement had enough space to accommodate the reinforcement. Prestressing was also considered to decrease the area of reinforcement and was applicable without causing excessive stresses at erection for pier caps.

The column to pier cap connection region was considered to be the extension of the column into the cap. Moment and axial load reactions at the top of the columns were obtained from the analysis in which the column to cap joints were fixed. In reality, the precast joint would be a partially rigid joint rather than the full moment resisting joint

assumed, resulting in smaller actual joint moments. In order to conservatively design the connection, the forces at the column top were obtained from the analysis with rigid joints.

Two connector configurations were generated, with one and another with two lines of connectors in each pocket as shown in Figure 3-10. The second configuration increases the (transverse) moment arm between the connector bars and is for cases where the first configuration is insufficient to transfer the required moments.

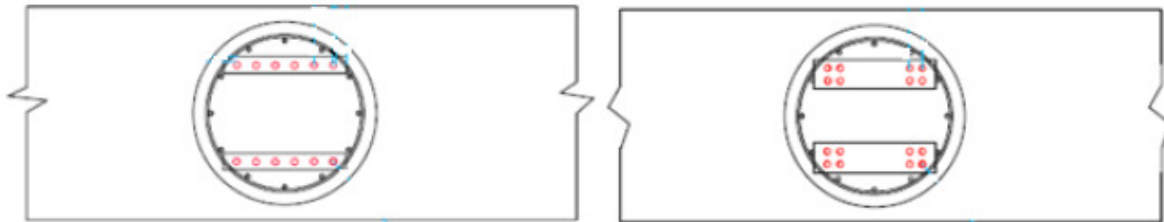

Figure 3-10 – Connector bar configurations for 36in. diameter pier: Configuration I (left), Configuration II (right)

Moment and axial load interaction diagrams were created for several of the proposed connector sizes and configurations as shown in Figure 3-11. The number of connection bars belonging safely to the nearest P-M interaction curve enveloping the actual forces was chosen for use. The reactions belonging to the bridges of the specified span length and the moment axial load capacity diagrams of several connectors are shown on the same figure. (Figure 3-11) (Table 3-4) Shear was also checked.

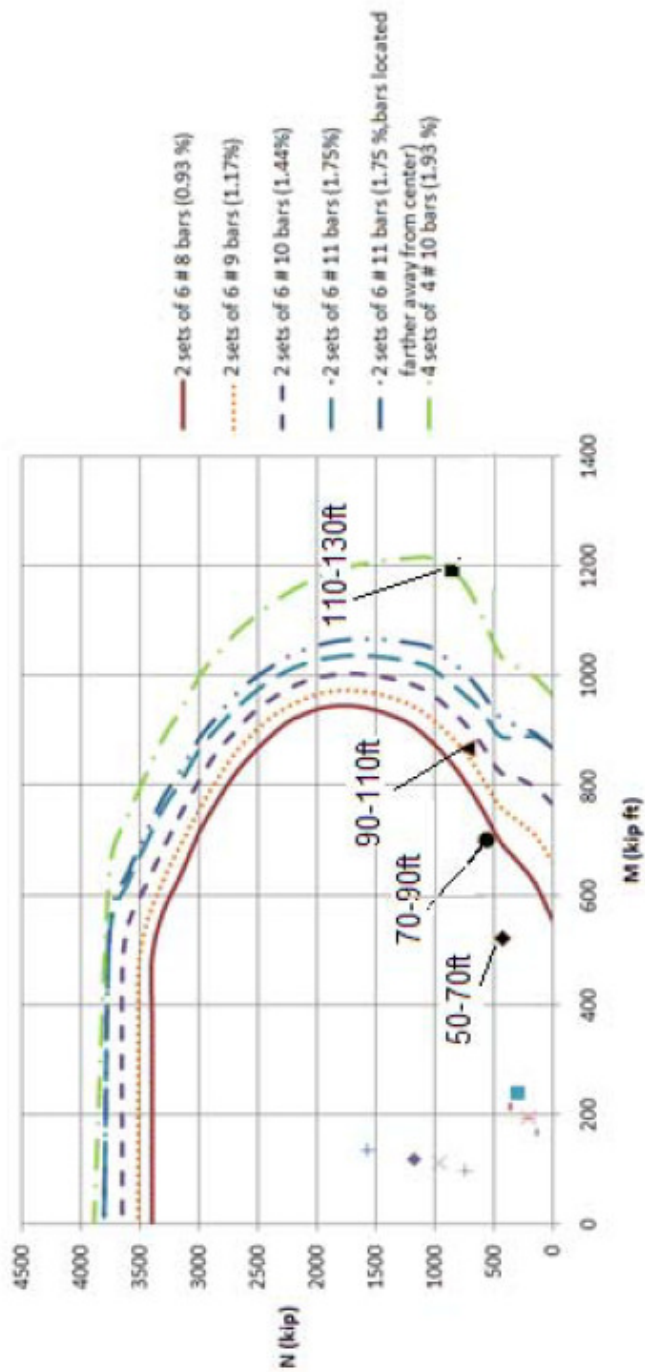

Figure 3-11 – N-M envelopes for grouted pockets and the reactions enveloped

Table 3-4 - Connectors chosen for pier caps supporting superstructures in various span ranges (pier cap to column joint design example can be found in appendices in Pier Cap Design Example)

Span Length (ft)	Connector bars (Conf. I has one layer of bars, Conf. II has two layers per pocket – Figure 3-10)	Design Loads (M-N)
50 -70	2 sets of 6 # 9 bars (Configuration I)	520 ft-kip – 420 kip
70-90	2 sets of 6 # 9 bars (Configuration I)	700 ft-kip – 556 kip
90-110	2 sets of 6 # 11 bars (Configuration I)	867 ft-kip – 730 kip
110-130	4 sets of 4 # 11 bars (Configuration II)	1192 ft-kip – 852 kip

The method to connect pier to pier cap for concrete piers and concrete filled steel tube piles is to place a separate set of reinforcement bars into the ducts in concrete pier or into the steel tube pile before grouting and then the pier cap will be place on top of pile or pier accommodating the reinforcement in the block outs. This will provide greater tolerance than having fixed reinforcement protruding out of the pier or pile end.

Chapter 4: Alternative Contracting Methods

When the cost of a system is used as a measure of efficiency, the evaluation is not complete unless the cost is analyzed in relation with the expected outcomes of the project. The primary motivation of this project is accomplishing rapid construction. Therefore, the cost analysis cannot be studied independent of time savings. For many cases an increase in the initial cost of a project is expected with precast substructure systems as opposed to a conventional system.⁴ However, reduced construction time may counteract or overcome this increase.

4.1 Cost Analysis

The effect of time on the construction cost has been noted. The traditional parabolic cost versus time curves, however, do not consider the effect of the user costs or life cycles costs so the lowest point does not really give the optimum cost. The user cost, is proportional to the time that the road users are affected by the construction and increases as the time period gets longer with a rate depending on the average daily traffic.³⁹ The following graph summarizes the general nature of cost versus time relations. (Figure 4-1)

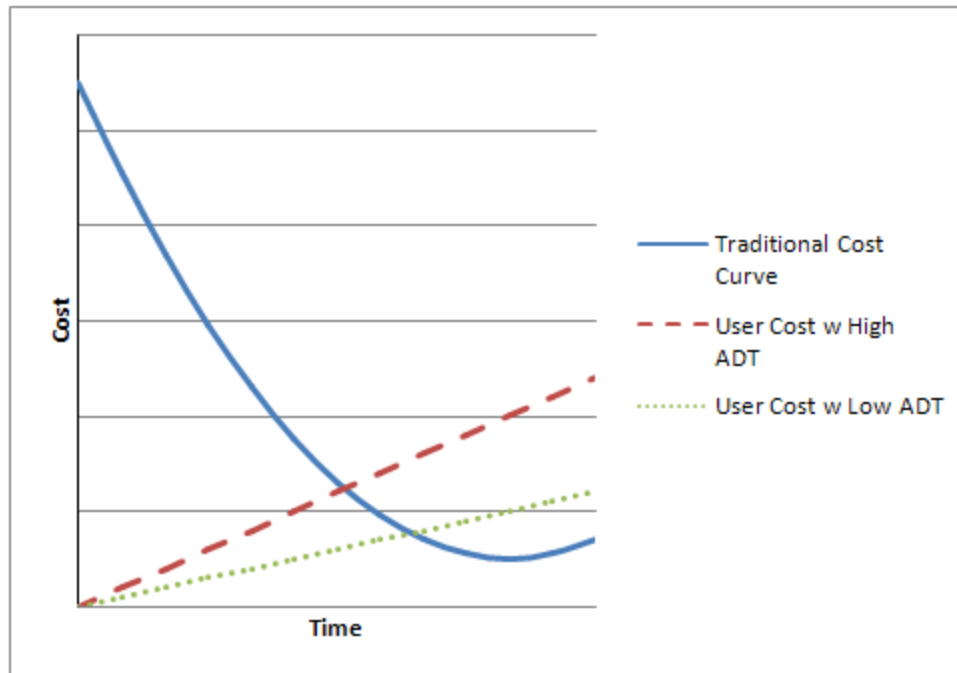

**Figure 4-1– Traditional Cost and User Related Costs with High and Low Volume
Traffics with respect to Time³⁹**

When the user cost is added to the traditional cost which includes initial construction cost only, a shift of location of the lowest cost to a shorter time is observed.³⁹ (Figure 4-2) The shift is more pronounced for roads with high average daily traffic values. These plots show that shortened construction durations can result in cost savings if the cost analysis includes the user costs. User cost, however, are not precisely known and vary on the project location and traffic type.

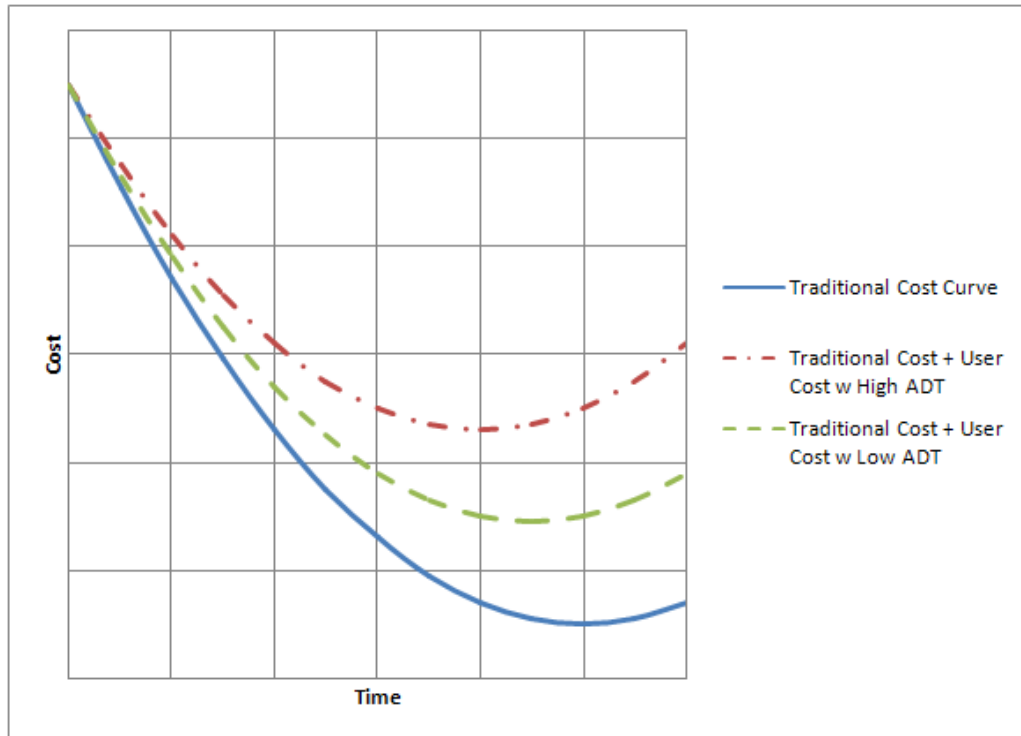

Figure 4-2 – Total Cost which Includes the Traditional and User Related Costs and the Traditional Cost Curve Only³⁹

4.2 Alternative Contracting Methods

Contracting methods involving the time effect in the cost rather than only considering the lowest bid were investigated to better represent the value of a project utilizing precast substructure components for rapid construction. Some of the contracting methods encouraging shorter project durations are briefly given here: design/build, A+B bidding, and lane closure.

In design / build contracting, the design and construction is performed by a single party which eliminates multiple contracts. Contractor can predict the construction process at

the design stage and improve constructability. This method is used to shorten project time for situations such as emergencies.

A+B bidding reflects costs associated with the project duration to the project bid. A and B represent the cost of the bid items and the cost of the project duration respectively, combined to make up the total bid amount for picking the contractor. B is calculated by multiplying the daily cost to the road users by the construction time. This way, the bidders are encouraged to use innovative techniques to keep the construction time short. A+B bidding is considered for cases where road closures and detours are a burden for traveling public or freight transportation, which matches well with the goal of this research. The location of the bridge is also important for the decision to use precast technology. Effect to the road users such a long detours can be very pronounced for high traffic volume roads. This contracting method was practiced for the St. Croix River Crossing Bridge in Wisconsin where construction duration and environmental effects were important.

In lane rental contracting, a fee for lane rental is introduced. The contractor is charged an amount for the lanes which have to be occupied by the construction, forcing the contractor to shorten the construction duration. Lane rental method was used for the Marquette Interchange project for which the road closures were a potential problem due to high traffic volumes.

In addition, incentives or disincentives based on the completion time of the project can be used to ensure rapid construction. These can be applied on a daily or hourly basis depending on how critical the work is.

Besides the factors affected by the construction time such as the effect of traffic delays, detours, need for temporary bridges; environmental effects, and improved work zone safety, an improved project with longer life due to better quality control and durability can also be considered in a life-cycle cost analysis of precast bridges. Repetitive use of forms and modules and thus standardization is essential to reducing the cost of a precast system. If custom forms are built for each project, precasting has less advantage since a contractor could as easily precast on site and avoid shipping expenses.

Chapter 5: Initial Summary

This chapter summarizes the conclusions from the first phase⁴⁶ of this project that has been explained in previous chapters. Being motivated by the success of existing projects completed by others using precast substructures, WisDOT intended for this project to generate a system of standard precast substructures for Wisconsin to simplify construction and reduce construction time. Components of candidate systems were selected based on the demand in Wisconsin. Standard geometries were determined according to weight and size limitations which would allow easy shipping and crane placement. A series of possible connection types are also compiled in this thesis as well. Standard precast abutment sections supported by pile foundations and precast pier cap sections on cast in place columns were proposed. The systems are summarized in the figures below (Figure 5-1) (Figure 5-2).

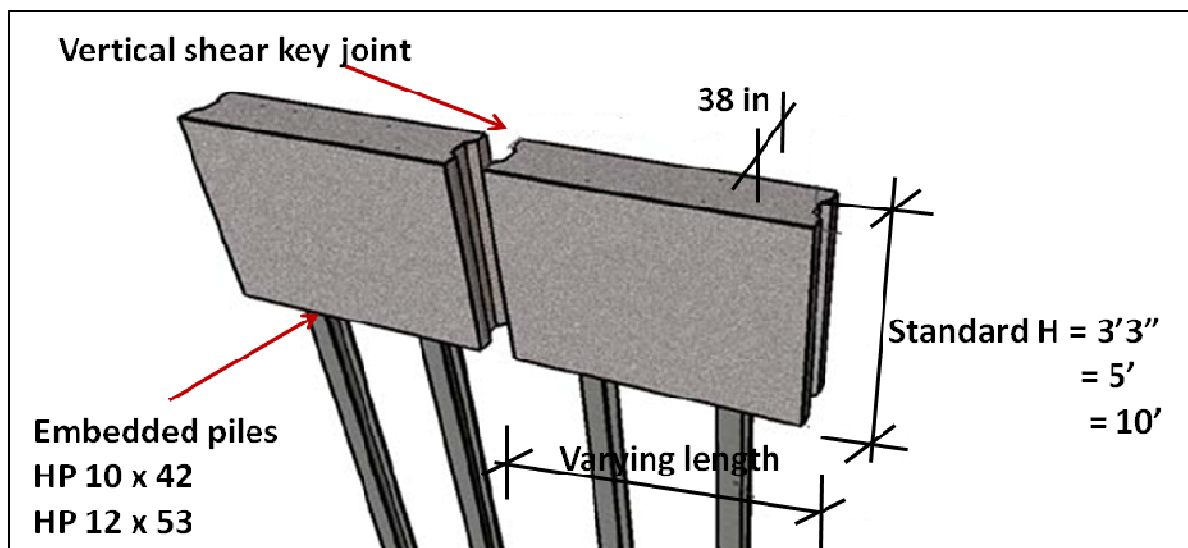

Figure 5-1 – The Standard Precast Abutment Modules

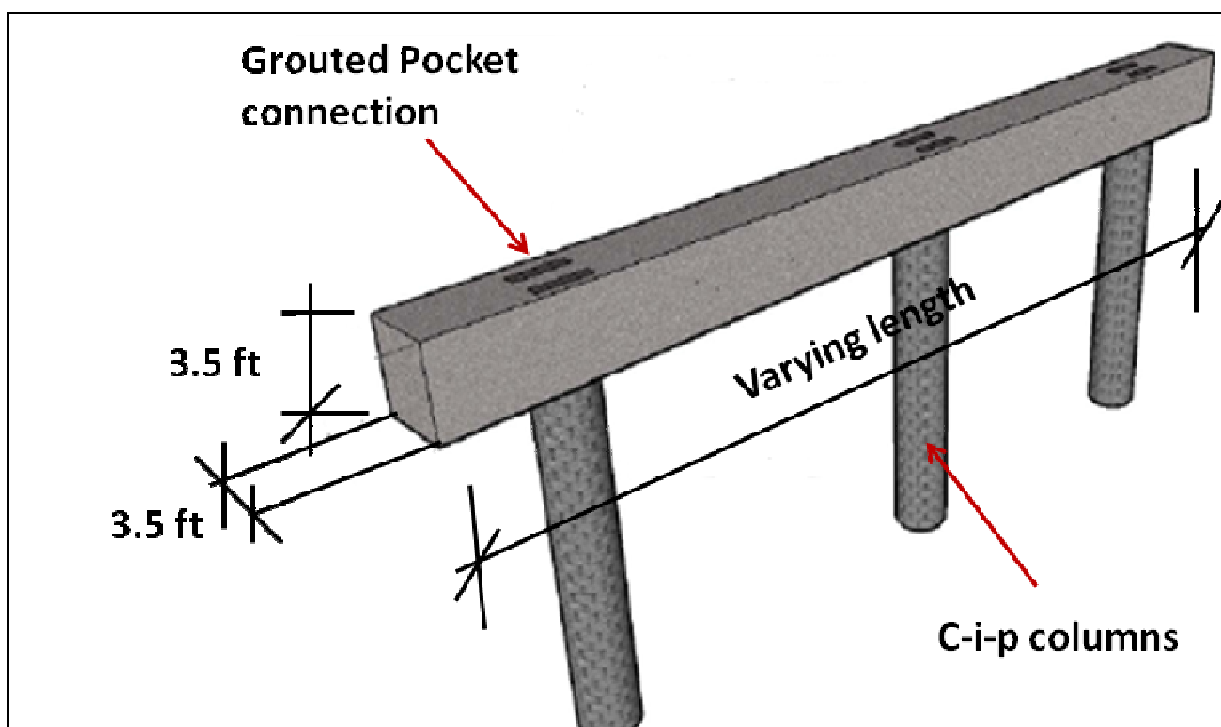

Figure 5-2 – The Standard Precast Pier/Bent Cap

Maintaining similarity of precast structures to current cast in place structures was considered in order to take advantage of the familiarity of contractors and designers with existing systems. For some cases, however, simulating cast in place construction may not be an effective solution and adjustments specific to precast construction should be made. This is especially the case when emulating cast in place results in very heavy components that are difficult to ship and require large cranes to erect.

Simple connections were selected for the precast abutments in the use of keyed concreted joints and for pier caps in grouted pockets with embedded reinforcing.

Although, connection types have been selected and recommended for WisDOT, other connections such as welding or post tensioning have uniquely attractive performance

characteristics and should be considered for future adoption in Wisconsin. Welding leads to minimal cast in place work and is one of the fastest methods of connection. Post tensioning is a secure way of load transfer between members where necessary and leads to long lived durable uncracked structures. These connection types are not currently preferred by the DOT however trial projects in the future may prove their efficiency.

Similarly, new types of abutments using exposed piles backed by lightweight backfill retaining walls and topped with standardized precast pier/pile caps could be a very efficient alternative to heavier solid concrete abutment bodies with embedded piles. This option may provide ease in erection, reduce required crane capacity, improve constructability and significantly reduce costs.

Aesthetics was not featured as one of the main goals of this research and was dominated by other considerations such as standardization, simplicity in geometry, ease in details and economy. Precasting, however, can still incorporate aesthetics by using decorative finishes. Form liners can be used to create texture on the outer surface of elements like stone or brick appearance. Colored concrete and sandblasting for exposed aggregate are also options which might be provided with precast concrete to improve the visual image.

For cases where the construction site is in a distance from the precast plant, where transportation cost get high, on site casting near the construction site using mobile ready mix plants may be considered.

It is expected that with pilot projects in Wisconsin, the systems will be better understood and necessary modifications will be made. Although the initial cost of the system is often used as an evaluative comparison, the long term cost benefits and user cost benefits

in shortened construction times should also be considered. Enhancing precaster participation by convincing the precasters of standardization and continued use is essential.

Chapter 6: Application of Pilot Abutments on Baldwin Bridge

To test the proposed precast abutment concepts, Wisconsin used a precast substructure for the first time in Wisconsin on a U.S. Highway 63 Bridge with a span of 50 ft over the Rush River just north of Baldwin, WI (B-55-217).

The abutment panels used in Baldwin were based on the standard abutment panel plans developed in the first phase of this project and emulated the size and shape of Wisconsin's normal cast in place abutments with embedded piles. Figure 6-1 is a picture showing the cross section of the abutment segments that were utilized in the Baldwin Bridge. The voids, in which steel HP piles are placed, have full depth throughout the length of the abutment segment. The simplicity of construction of an abutment very rapidly with modules as seen in Figures 6-1 & 6-2 can quickly become apparent.



Figure 6-1 – Cross section of the abutment segment

The Baldwin project proved that precast substructure systems can be very effective in attaining the goal of rapid construction. Eight precast panels, approximately 41 kips each, were set into place to complete the abutment for a staged bridge construction, in six hours.

A total lineal length of 96 ft of abutment was placed in the first day on the Baldwin Bridge. On the second day, forming was placed over joints between the panels in two hours with two workers and the joints were grouted in an additional 2.5 hours. The eight panels required minimal forming and a total of 10.5 hours to place and finish with 4 workers on the job (a total of 42 man-hours). This would be compared to 11 to 14 days for placing

reinforcing, forming, pouring and curing on a similar cast-in-place abutment project (350 man-hours).

The Baldwin project clearly showed that rapid construction is achievable with precast concrete substructures. The visual quality of the completed abutment system appeared to be better than a typical cast in place abutment.



Figure 6-2 – Setting the second abutment module in place

Several situations encountered in this project provided an incentive to develop an improved revised system before standardization in Wisconsin, including:

- Contract bids that were higher than expected--

The contract bids on the Baldwin Bridge were unexpectedly high. Discussions with the contractor proved that this was primarily due to the need for a 100 ton crane to place the heavy panels combined with a long reach. Normally contractors building a short span slab bridge in Wisconsin would use a smaller crane. The contractors also had no prior experience with precast concrete substructures.

- Contractor concerns --

The contractor on the Baldwin job explicitly reported concerns about working with components of the size and weight of the precast modules. There was particular concern about the safety of workers when moving and placing the large components. This appears to be a response particularly associated with lack of familiarity and a new system, since the same contractors regularly are involved in erecting precast concrete girders that are much heavier and larger.

Moving the large crane from one side of the bridge to the other, to erect the second abutment, created additional concerns and would have been particularly difficult if staged construction had not been used and the bridge was not available for crane movement since a crane breakdown and a long detour route would have been required.

- Additional piles

Additional piles needed to be driven to support the precast panels compared to the number that was originally designed for the bridge on a cast in place abutment. Due to the 10 ft height of the abutments, the width of each panel was limited to control the weight. Since the design was predicated on having at least two piles per panel, and

the panels were narrow, additional piles were needed. This will always entail an additional cost.

- Pile alignment

The contractor and State WisDOT engineers were concerned about potential pile misalignments making the placement of the panels over piles difficult. The contractor is expected to use pile templates during driving to meet the more stringent pile tolerances specified in the contract. The tighter tolerance probably resulted in a higher bid for the pile driving.

All of the concerns listed above may have contributed to a high cost for the Baldwin Bridge. Rapid construction and use of precast components should be expected to be more costly, but the cost impact can be reduced by specifically addressing some of the main concerns noted above with revised module designs.

Chapter 7: Recent Efforts of Other States in Precast Bridge Substructures

Many states have started using different Accelerated Bridge Construction (ABC) techniques after the recognition of the important effects of construction time on highway users. There is variety of methods that different DOTs and engineering companies have applied so far. Clearly one of them is to use precast concrete substructures and superstructures to minimize construction time and reduce worker exposure to hazardous conditions.

A further example of a more recent application is the utilization of precast pier bent caps to replace the Robin Hood Road Bridge during the 2009 summer by the West Virginia Department of Transportation (WVDOT)⁴⁰. Erection of the precast pier cap used in this project is shown in Figure 7-1. A standard pre-stressed box beam with dimensions of 4ft width and 4ft - 6in depth with 58 - 1/2in diameter strands was used for the pier cap. This project also intended to use precast integral abutments with a cast in place closure; however, the abutment was built with conventional methods.



Figure 7-1 – Erection of Precast Pier Cap⁴⁰

The Utah Department of Transportation (UDOT) has widely implemented the use of ABC in different projects with precast deck panels, precast abutments, precast approach slabs and Self Propelled Modular Transports (SPMT) of components into place. UDOT has developed standards for several aspects of accelerated bridge construction which can be accessed through their website⁴¹. Standards include typical detail drawings for precast substructure elements, recommended tolerances for precast elements, design and construction manuals, and special contract provisions.

In the first application of rapid bridge construction technology in the State of Michigan, a bridge replacement project was chosen for a 245 foot four span, three-lane grade

crossing over US-131⁴². Precast abutments (see Figure 7-2), precast multi column piers, precast caps, precast pre-stressed I-beams and a precast deck post-tensioned longitudinally to have continuity were utilized in the project. Similar to our phase 1 proposed abutments, steel piles were embedded into the precast concrete abutment modules and then the remaining voids were filled with grout to achieve a rigid joint. Time saved with precast construction can be seen in Table 7-1.

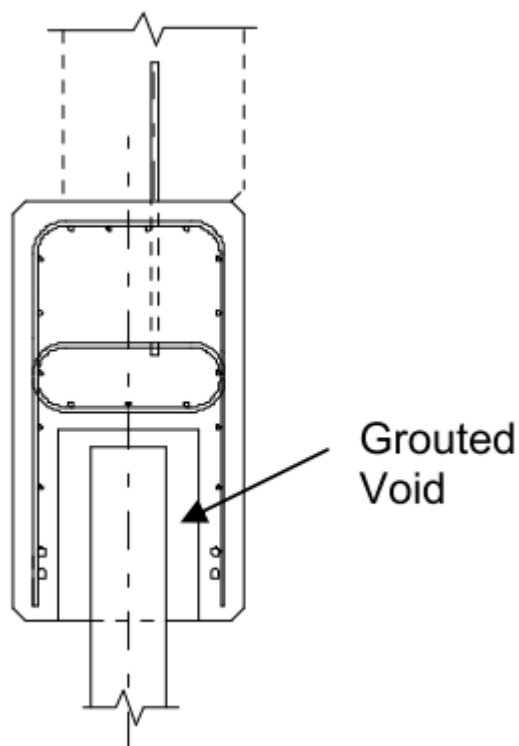

Figure 7-2 – Precast Abutment used in Michigan’s Replacement Project⁴²

Table 7-1 – Construction Schedule Comparison⁴² which compares total time to construct specific elements of the bridge with different techniques (the units are calendar day)

Element	ABC	Conv.	Savings
Abutments	25	32	7
Piers	20	41	21
Girders	10	10	0
Diaphragms	10	10	0
Deck	22	43	21
Barriers	14	14	0
Total:	73	129	56

Chapter 8: Revised Systems / Improved Bridge Abutments

8.1 Bent Cap Connections

A solid rectangular cross section for a pier cap or pile cap was originally chosen for its simplicity and overall easiness of manufacturing and subsequent inspections. The extra construction demands caused by the heavy components in the Baldwin Bridge suggested that shorter (than 42 ft) and lighter precast pier components would also be more attractive and economical. This was an impetus for an improved cap system with shorter pieces and connections to be developed.

Rather than just acting as a pier cap, the same standard section is expected to be used as a pier cap, a pile bent cap, a cap on lightweight abutments and also by itself as a shallow abutment module. Standardization of a section for all these functions will greatly increase the repetitive form usage and make precasting a viable alternative. Varying depth precast pedestals will be set on the top of the cap (or abutment) and dowelled or keyed in place to create stepped girder seats for the roadway crown. In doing so, custom modification of the bent cap for different girder seat elevations on each project will be avoided.

Three new alternatives for connecting adjacent cap segments were developed: welded steel plate connections, spliced reinforcement connections and post-tensioned connections. As noted previously in the phase 1 study: the connections in a bent cap must be strong in transferring moments. For all three connection types, the joint of the bent cap was assumed to be placed over the piers. This can eliminate the need for temporary scaffolding if cap pieces can initially be simply supported during erection. The cap connection would need to resist negative bending, with tension at the top. The welded or spliced reinforcement connection

would be needed at the top. Both pier-cap and cap-cap connections would need to be completed at the same location providing a challenge in design. These connections, intended for non-seismic resistant applications, are described below.

8.1.1 Welded Steel Plate Connection

The first cap-cap joint system is a welded steel plate connection. With this connection type, there will be steel plates embedded into the top of each cap component during production with an added drop in splice plate (see Figure 8-1). After putting the caps in place on site the gap between modules would be grouted, then the two steel plates will be joined by welding. This type of connection is assumed as “pinned” if the joint is not grouted and then would be designed for providing “system integrity” but not to transfer flexure or vertical shear forces across the joint. If the joint is grouted it could be considered as continuous, with the grout providing the compression stress block and the weld providing a tension tie at the top. The welds would then need to be designed for the tension force necessary to resist the maximum induced bending moment. A preliminary design example can be found in appendices section named as “Welded Steel Plate Connection for Bent Caps”.

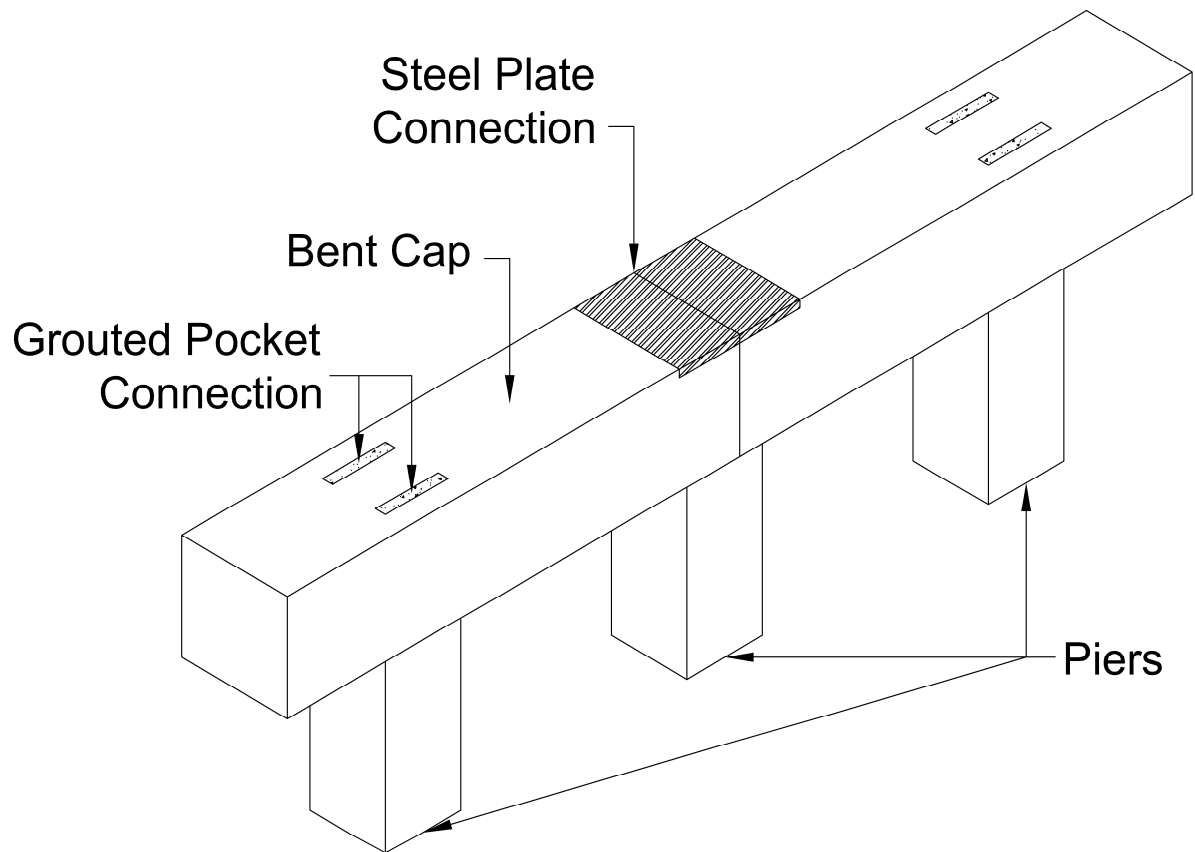

Figure 8-1 – Isometric View of Welded Steel Plate Connection

Completion of this type of connection is very fast if it is designed as a hinge, since there is no need for cast in place concrete construction or grouting. Leveling bent caps and welding them together is sufficient for integrity. For better durability of the joint, the steel plate should be covered with a masonry layer after the welding operation. If cover masonry is not provided, then stainless steel should be used in the plates and welds.

In the case where welding is done, quality control of the welding is a primary concern. Particular with a moment resisting connection, the fatigue strength of the welded region needs to be determined and induced stresses must be below the fatigue limit.

Another concern is the fact that there is an eccentricity during force transmission between the steel plate and embedded tension reinforcement as shown in Figure 8-2. The design of the embed bars must be detailed to avoid a failure near the plate due to localized bending forces in the bars from the eccentricity. Apart from those concerns, this connection type would be a fast and inexpensive alternative for the precast bent cap system.

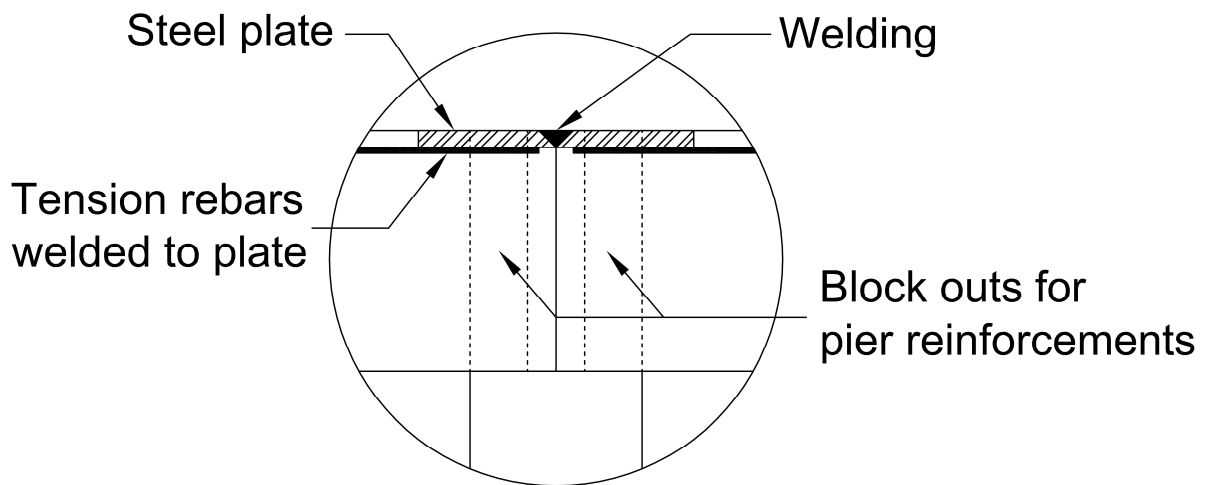

Figure 8-2 – Cross Section View of Connection

The connection between the pier and bent cap is also needed at this same location. The connection will be of the same type as described in the phase 1 research: a grouted pocket with reinforcing bars from the pier extending into the pocket. The designs and capacities of those connections were provided in Table 3-4. In this case, using pockets to accommodate pier reinforcements (pockets are shown as dotted lines in Figure 8-2) will solve this issue. After forming those pockets, steel plates can be placed over them. Yet, there should be holes on plates in order to pour grout into pockets.

8.1.2 Spliced Reinforcement Connection

The other cap-cap connection option is to use spliced reinforcing bars sticking out from both cap modules. Reinforcement is left protruding out of the end of each cap segment. A separate set of drop in reinforcement bars form an overlap with the protruding bars and are grouted into place. Two different options for this connection are shown in Figure 8-3 and Figure 8-4. These connections can readily be designed to provide flexural and shear continuity across the joint.

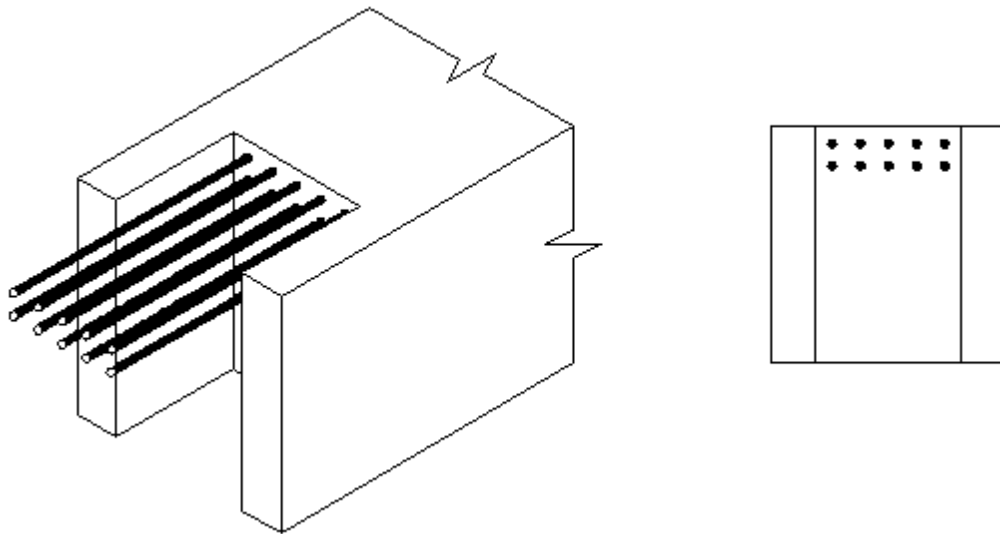

Figure 8-3 – First Option for Spliced Reinforcement Connection

The tension splice length should be checked at the connection region for the overlapping. Cast in place concrete is used with this connection and there is pouring and curing time for concrete to gain its strength, this might delay the construction time unless high early strength materials are used. Besides that, the primary disadvantage occurs at the precasting plant where the tolerance in bar locations needs to be held very tight to avoid

interference of bars in segment with the adjoining bars in the second module. The precaster's forms must also allow bars to exit from the ends.

At the splice region, bars coming from pier should also be accommodated in a vertical pocket and grouted together with the tension bars to achieve two different connections at the same location. To avoid this, the module to module joint could be moved away from the pier location but then bottom bars would need splicing, a much more difficult task.

An alternate detailing would have the top bars extending only to the end of each cap module. The bars would then be spliced by dropping separate splice bars into place once the cap modules have been erected. This method would allow bars in each precast module to be located in the same positions, rather than being offset so that they overlap. The disadvantage, however, is that the blockout length and amount of cast in place concrete would double due to having twice the total splice length.

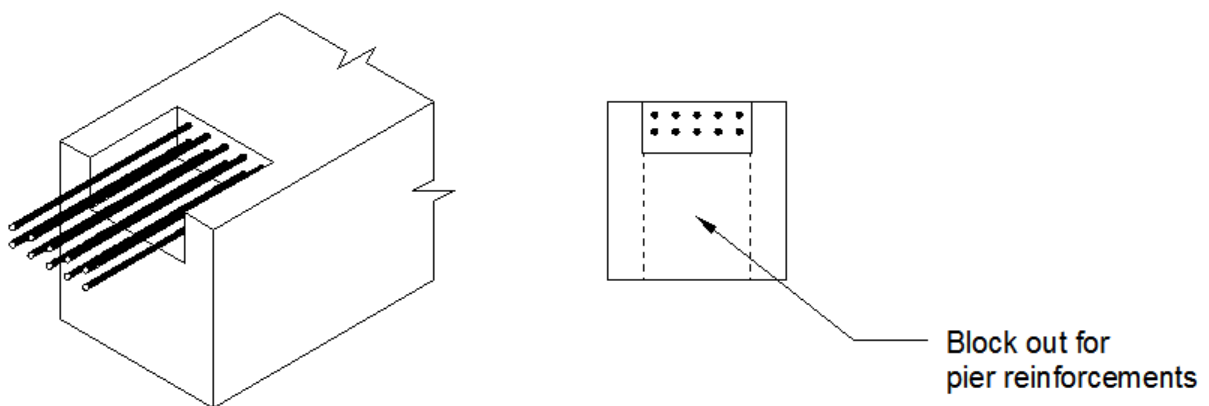

Figure 8-4 – Second Option for Spliced Reinforcement Connection

Since all the reinforcement is embedded in concrete, durability is not a concern. It is also foreseen that this method is the best to apply when there is cast in place piers with reinforcements already put in. A preliminary design example can be found in appendices section named as “Spliced Reinforcement Connection for Bent Caps”.

8.1.3 Post – Tensioned Connection

The post-tensioning of two adjacent cap girders together is the most desirable connection alternative. Ducts and end anchorages for post-tensioning tendons are placed inside the caps during the precast fabrication. Before post-tensioning, the gap between the components is filled with a high performance grout. Post-tensioning can usually be applied within 24 hours of the joint grouting and can immediately be followed by grouting of the ducts. Once the section is post-tensioned, all of the remaining superstructure erection can continue. The post-tensioned joint can easily be designed to transfer flexural and shear forces between cap components. This alternative is fast, durable and reliable.

Post-tensioning has not been commonly practiced by WisDOT, for that reason this method of construction might be costly until local contractors become familiar with the processes. However, as is the case with all new methods, cost reductions will occur over a time period. In this case, either pre-tensioning or regular reinforcement is needed in the cap to carry dead load and handling & shipping forces before erection.

The primary advantage of post-tensioning is that designer can control cracking of the entire cap as well as the joints resulting in a very good durability since water cannot penetrate and reach the reinforcement.

Block outs in the bent cap, as shown in Figure 8-4, are needed to splice the post-tensioning ducts as well as vertical pockets for the pier to bent cap connection are required and should be placed to avoid interference. A preliminary design example can be found in appendices section named as “Post-tensioned Connection for Bent Caps”.

8.2 Abutments

Precast module weight and crane capacity were proven to be of prime importance in the Baldwin Bridge experience, particularly from a cost viewpoint. Cast in place abutment emulation was shown to be uneconomical and difficult to handle for a precast abutment system.

A revised design process led to a recommendation of three potential improved abutment systems for use in Wisconsin. The new abutment modules were shaped with weight reduction and repetitive modularity as primary constraints. The lightweight abutment modules would require a cap to accommodate girders or a slab. An excellent opportunity for simplifying the module formwork and repetitiveness presented itself in using standard precast pier caps that have already been proposed above new precast abutment modules.

8.2.1 Pile Bent Cap with Hollow Wall Panels

The first proposed abutment system has a hollow wall module with an upper bent cap as shown in Figure 8-5. The upper cap could be eliminated to create a simpler construction.

The hollow precast concrete panels will be slid over the piles. This system allows the greatest tolerance in pile location, but requires more extensive field concreting. Reinforcement bars could be prelocated in the hollow panel prior to concreting and pockets

in the cap could be slid over the bars when the cap beam is subsequently placed. The pockets would be grouted after cap placement. Alternatively, the cap beam could be placed before the hollow panel is grouted and rebars could be put through pockets in the cap extending into the hollow panels. The whole void will then be grouted or concreted forming a connection between piles, wall panel and bent cap. Sufficient development length will be provided for reinforcement bars both in the bent cap and hollow panel. The embedment length for the piles can be varied, but a 3ft minimum length is recommended.

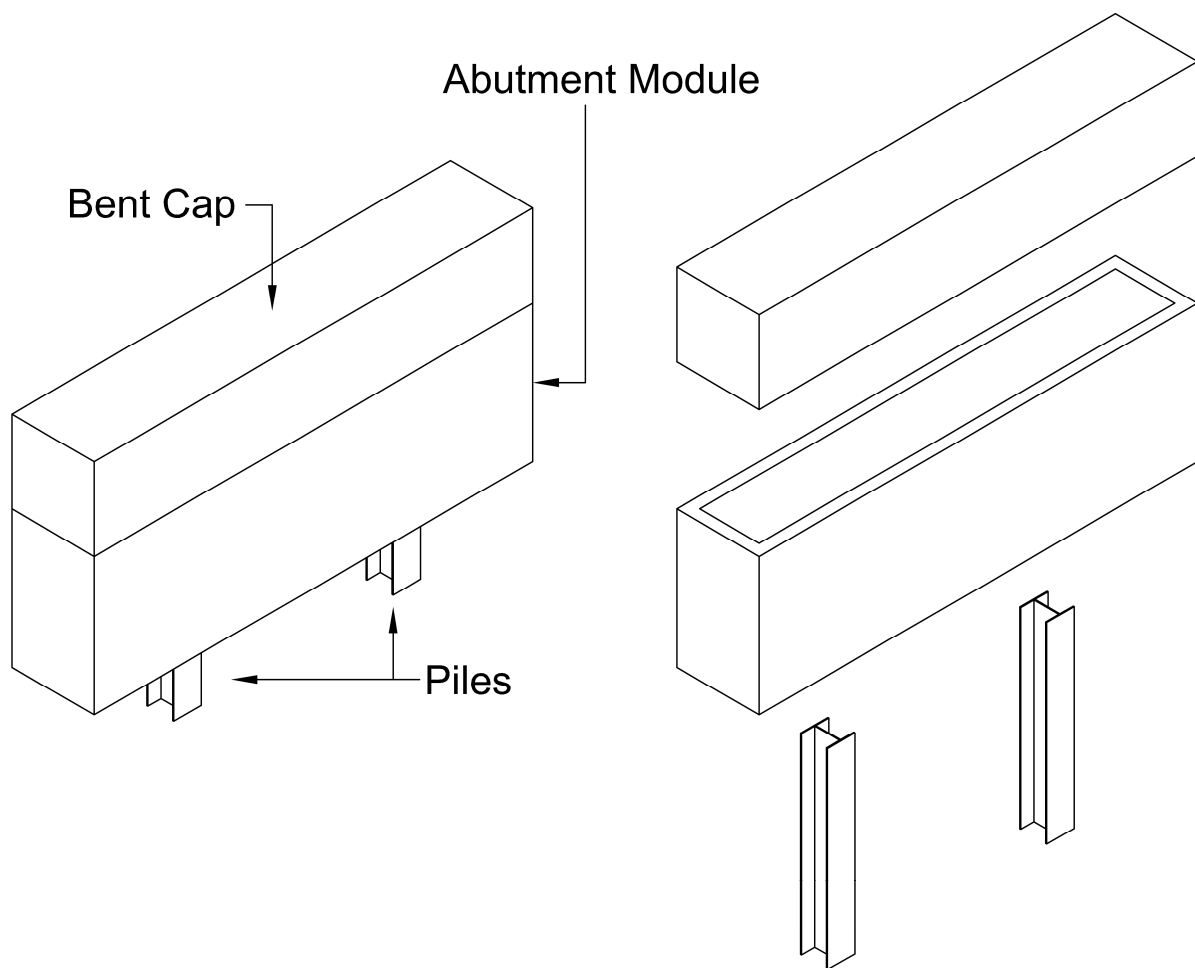

Figure 8-5 – Pile Bent Cap with Hollow Wall Panel

In this system the precast parts will be light. The minimum wall module length will be two times the center to center distance between two piles and height is variable depending on the project.

Talking about disadvantages of this system, a wall panel having a full depth hollow core could possibly cause some quality control issues during fabrication. Another concern might be the possible formation of cracks that might occur in the thin walls of the panel during fabrication or transportation. Finally, the amount of concrete/grout is larger than other systems that can lead to additional pouring, curing and setting time.

This system provides accelerated construction only in that it eliminates field construction of the abutment formwork and placement of reinforcement in the abutment body. Otherwise the abutment is basically identical to a normal pile embedded cast in place abutment. It is doubtful whether the time savings in formwork construction would justify the extra cost in the multiple prefabricated concrete components that are needed.

8.2.2 Full Length Socketed Wall with Bent Cap

Another alternative system for abutments is constructing full length socketed wall with bent cap (see Figure 8-6). The wall is attached to piles by means of sockets that are concreted after setting over the piles. The main intent of this design is to eliminate unnecessary concrete between piles.

The primary advantage of the socketed system is lightweight, because of the thin backwall, and tolerance allowed for the pile position. Piles will still have to be driven with smaller tolerance than for a normal cast in place abutment. There is no need to take protective steps for steel pile corrosion since they are embedded. Moreover, connections are

not complicated. Piles in pockets will be grouted providing a sound connection between the abutment module and piles.

A cap, identical to the precast caps used for piers and bents, will be placed above the socketed abutment body. The cap will be connected to the sockets using rebars embedded in the socket and pockets in the cap. The cap may be a single piece or a spliced cap as described earlier.

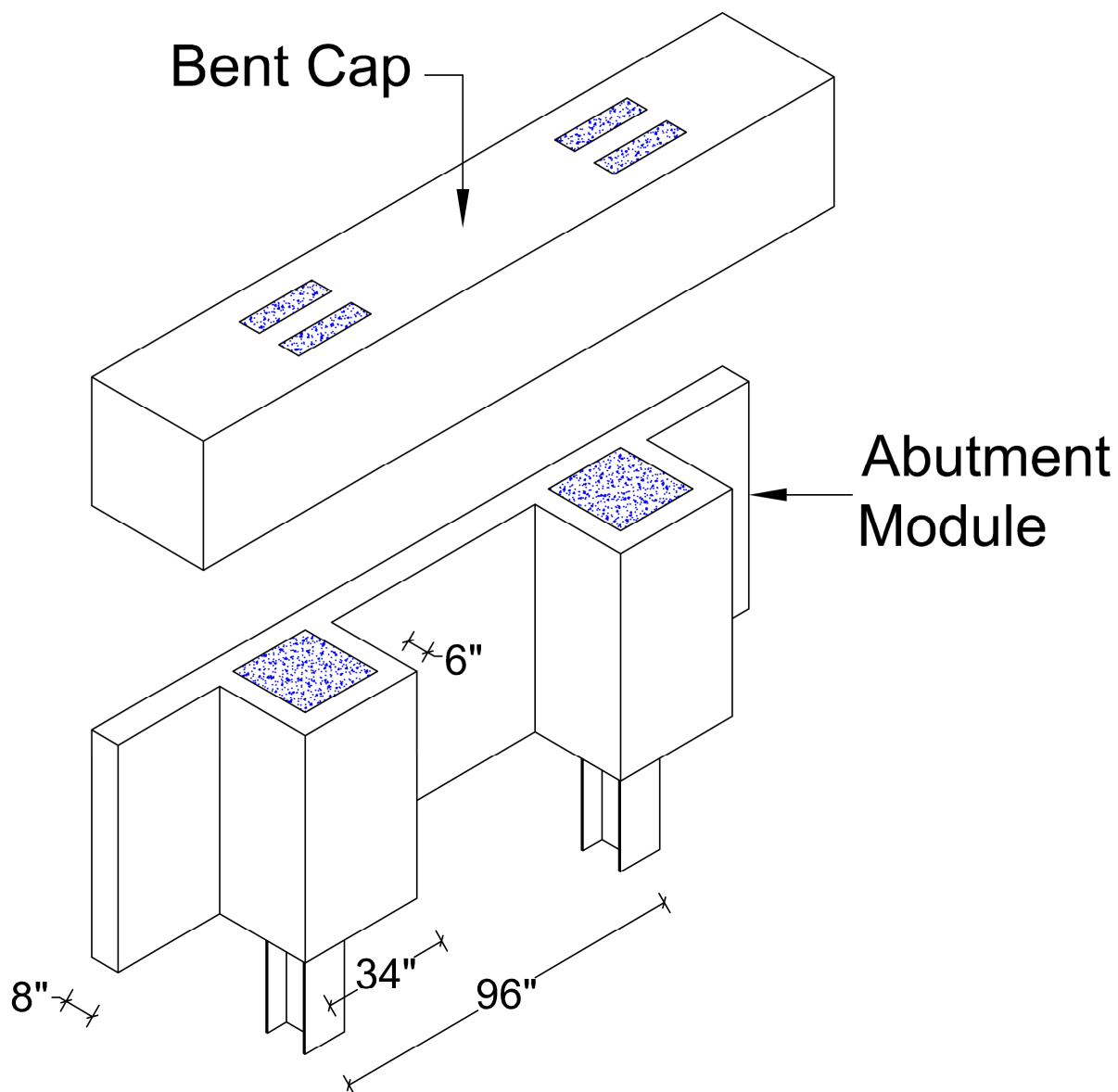

Figure 8-6 – Full length Socketed Wall with Bent Cap

The wall segments will be built with female keyed ends. The shear keys will be grouted after placing. Adjacent abutment modules will be tied together through the common precast cap. The forming of a full depth hollow section, however, might be a difficult task for the precast producer.

8.2.3 Limited Length Socketed Wall with Bent Cap

This system is based on the same concept as the full embedment type. The socket length is limited and topped by a solid concrete strut (see Figure 8-7). After placement the abutment panel over the piles, the pockets will be concreted through gaps adjacent to the upper concrete strut.

The embedment length for the pile into abutment should be at least twice the width of HP piles. For HP 10 x 42 and HP 12 x 53 piles commonly used in Wisconsin, the embedment length should be approximately 2 ft with a total socket length of 4 ft. A longer embedment length is preferred for extra moment resistance when large lateral forces from backfill are likely to develop. The short pile embedment length will allow piles that are not exactly vertical to still slide into the oversize pocket reducing the need for tight pile tolerance and problem with errors in pile driving.

It is anticipated that standard formwork for this model would be built with a 4 to 5ft. long socket, fixed width of 16 ft and a variable top form to allow the abutment to be built in varying heights as conditions demand.

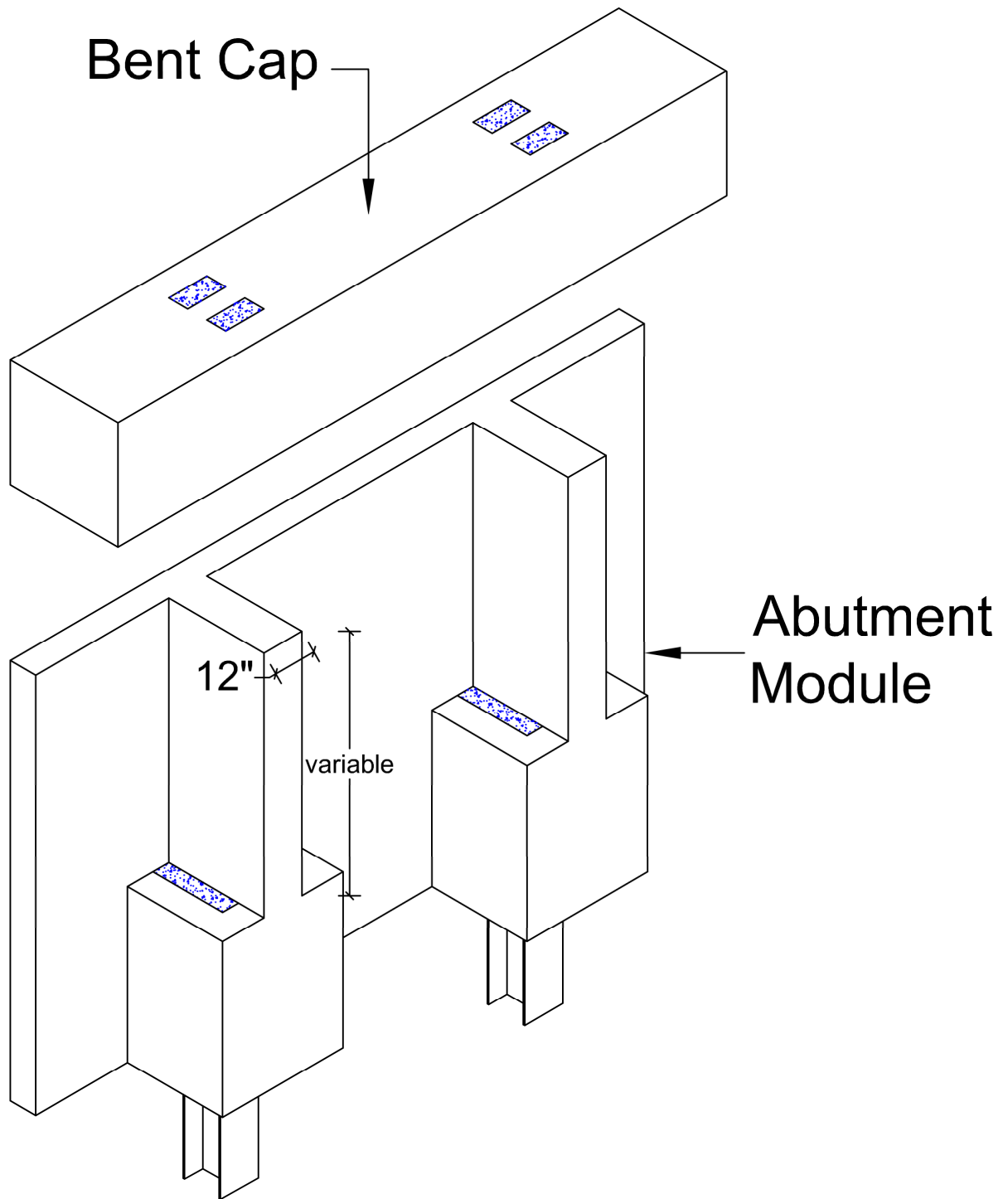

Figure 8-7 – Limited Length Socketed Wall with Bent Cap (other dimensions are same as Figure 8-6)

The bent cap will be connected to abutment with reinforcing bars in cap pockets and embedded at the tops of the struts during production, dowels drilled in after casting, or dowels placed into sleeves that are embedded in the struts – to be grouted later.

8.2.4 Connection Methods for Abutment Modules

Many methods for connecting adjacent precast modules have been used including post-tensioning, splice sleeve connections, welding, bolting and cast-in-place connections as explained before. Each has advantages and disadvantages.

Adjacent abutment modules for the proposed standards are connected by a grouted keyway joint (see Figure 8-8). Each module is fabricated with a female key at its edges and the resulting key is grouted. Built without reinforcing in the joint, this connection only provides for shear transfer out of the plane of the wall. Two piles are embedded in each panel and are intended to completely resist the loads applied, avoiding the necessity for force transfer across the joints and allowing use of the simple key joint.

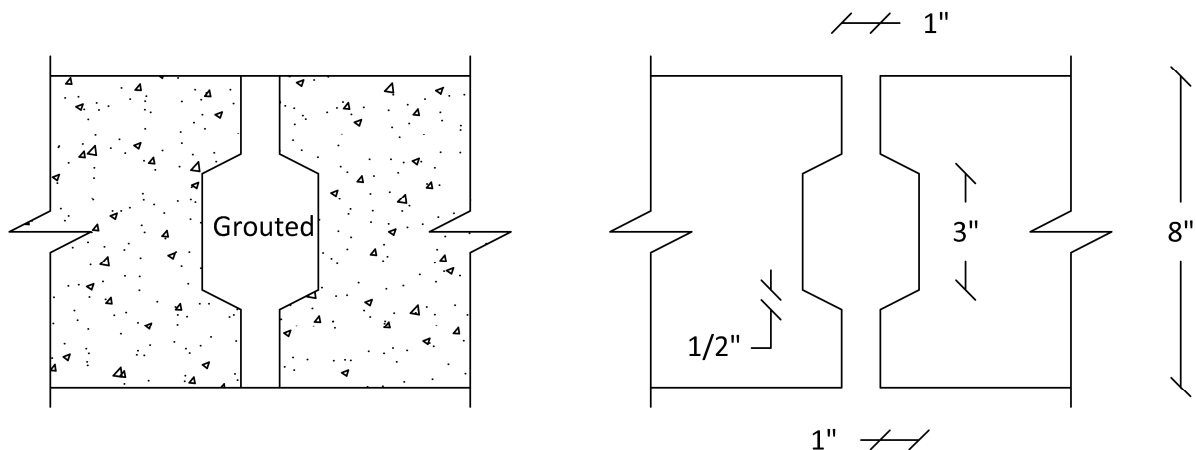
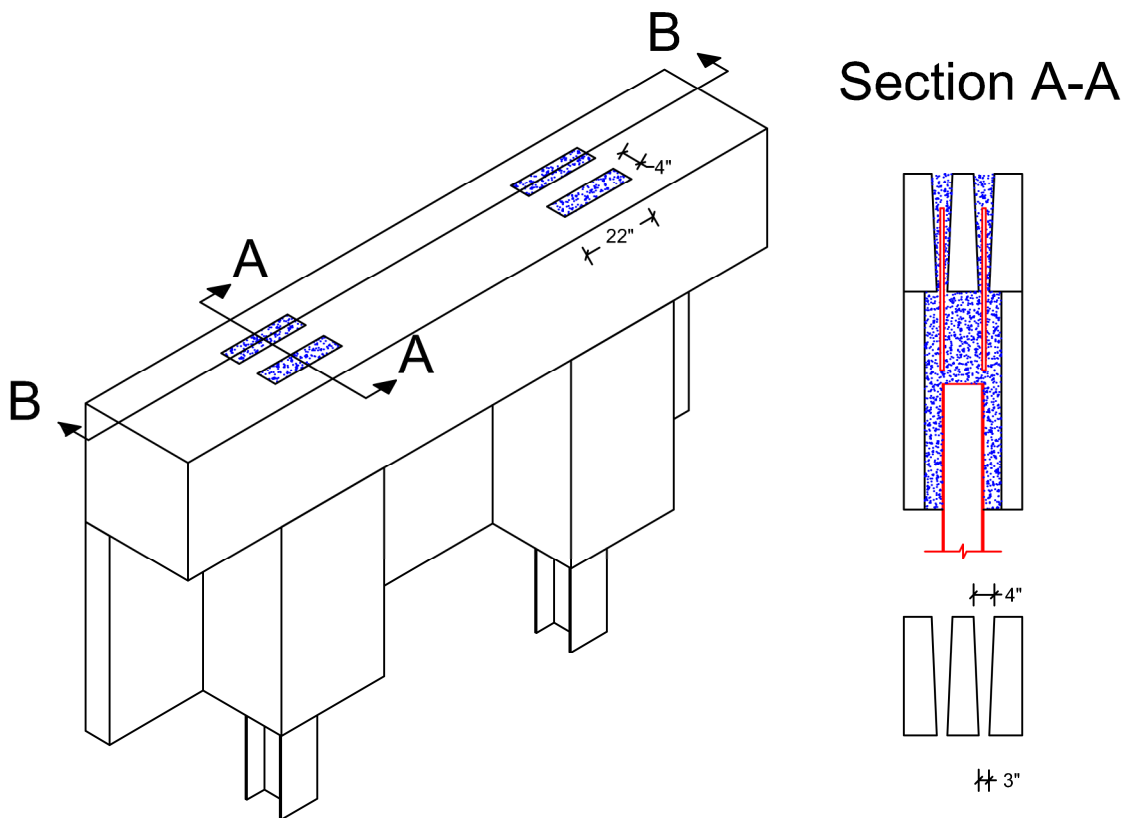

Figure 8-8 – Cross section view showing shear key for abutment module to abutment module connection

The connection between the precast cap and an abutment wall, piers, or piles in bents must be substantial to transfer superstructure forces into the foundation. Many of the general methods noted above could be used but a grouted or cast in place connection allows for large tolerances and does not require special subcontractors or difficult welding.



Section B-B

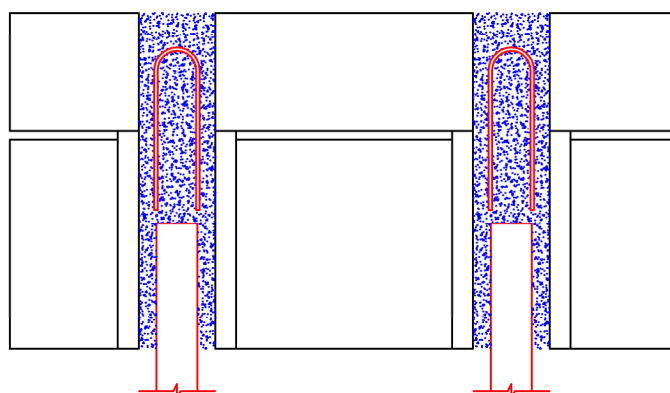

Figure 8-9 – Grouted pocket connection between cap and abutment module for full length socketed wall abutment type

In a grouted connection (Figure 8-9), reinforcement from the top of the precast abutment socket extends into open vertical pockets in the cap. In a similar manner, concrete piers or circular steel piles are attached to the caps by casting or drilling steel dowels inside the pier/pile ends and allowing the dowels to extend into pockets of the precast cap. The cap is temporarily supported on top of the abutment or on a friction collar with piers or piles. Although this method of connection needs a short time for grout to set and gain its required strength before continuing with construction above, it is easy to implement when compared to other type of connections.

8.2.5 Socket Region Analysis and Design Method

When piles are embedded in thick cast in place concrete abutments little special design effort is placed on facilitating vertical, lateral and flexural force transfer into the piles. The proposed lightweight socketed abutments, however, are far less massive and the force transfer from the pile into the thin walls of the socket must be examined.

Most of the socket connections that have been used previously or described in the literature are in the form of precast concrete columns placed in the sockets of precast shallow footings^{43, 44}. These column to footing connections are very efficient and commonly used for low industrial precast buildings in Europe and Asia. The shallow footings, however, have solid concrete around the inserted columns rather than thin walls.

The proposed abutments will have thin wall sockets intended to accommodate either steel or precast concrete piles and will not behave like sockets used in precast footings. In calculating the forces acting within the socket-pile interface a designer should consider shear friction transfer as well as bearing forces between the two components. This method is very

similar to the method shown by Osanai et al.⁴⁴ but includes some modifications. Taking an approach that neglects shear friction on the component produces a design that is overly conservative⁴⁵.

8.2.5.1 Analysis of Socket Forces Ignoring Friction

There are two primary loads applied on abutment bodies, which are horizontal and vertical forces. These loads must be estimated prior to design.

Horizontal loads are divided into horizontal earth pressure (EH) caused by fill and live load surcharge (LS) from vehicles (see Figure 8-10). Earth pressure loads from fill have a triangular distribution on the wall back face, zero at the top and largest at the bottom, assuming active conditions. While calculating this type of pressure behind the abutment wall, the Equivalent-Fluid Method of Estimating Rankine Lateral Earth Pressures explained in AASHTO LRFD 3.11.5.5 was used. This method can only be applied when the backfill is free draining. Here, it is assumed that drainage methods will be applied at the site to lower the water table behind the wall if necessary and this will keep the granular fill behind the wall drained all the time.

Horizontal loading due to live load surcharge from vehicular wheels is assumed to create a constant horizontal earth pressure, as explained in AASHTO LRFD 3.11.6.4. The constant pressure is calculated as the multiplication of the coefficient of lateral earth pressure (active conditions apply), unit weight of soil and equivalent height of soil for vehicular load. This equivalent height has been tabulated for designers in AASHTO to pick up the right value for a case (LRFD Table 3.11.6.4-1). Linear interpolation between heights is also allowed.

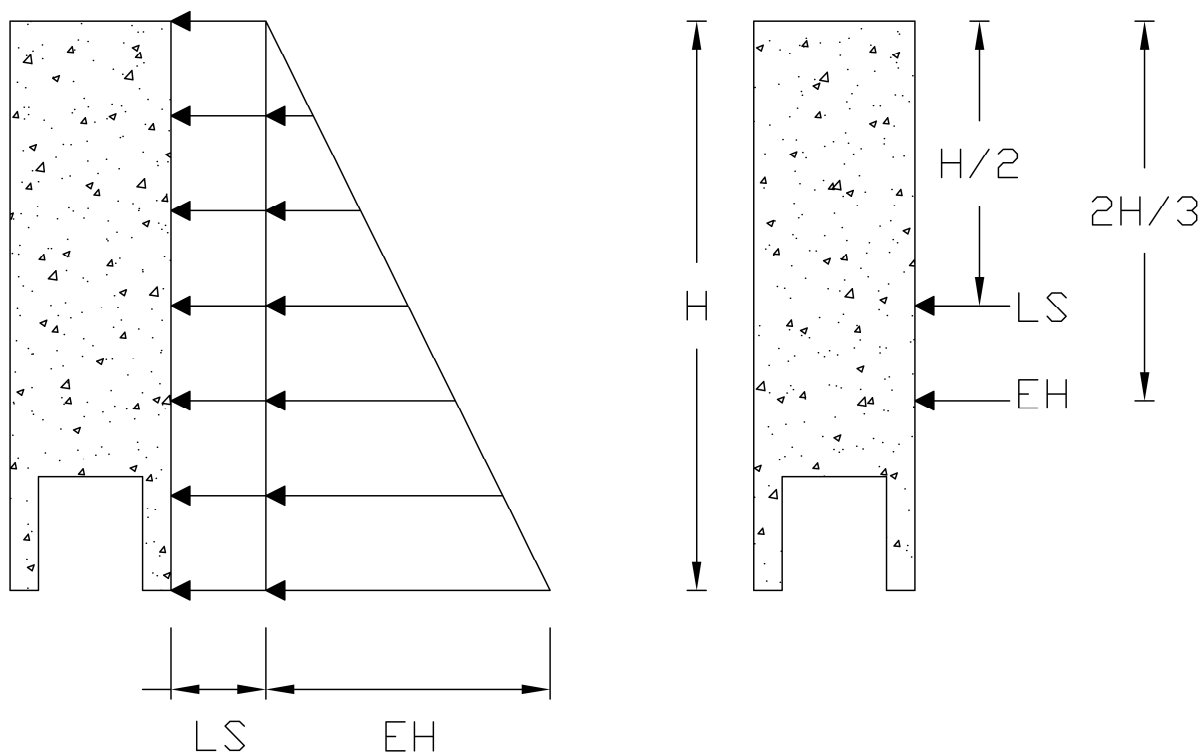

Figure 8-10 – Horizontal loads acting on abutment caused by earth fill (left) and resultant forces (right)

In addition to horizontal loads, there are vertical loads which are coming from the superstructure as dead load and live load. The sizes of these loads depend on the superstructure type and span (In design examples given in the appendices, vertical loads are assumed since the specific bridge geometries are not known). In order to be precise, all the dimensions of the bridge should be known so that the exact dead load and live load can be calculated and the total factored vertical load is known.

The factored forces at the top of the pile (Figure 8-11) are determined from the resultants shown in Figure 8-10 added to the factored vertical force divided by the number of piles. They are used to calculate interior socket compression forces and then for the design of

the socket region. These forces include axial force coming from superstructure, moment and shear force caused by backfill (N, M and P).

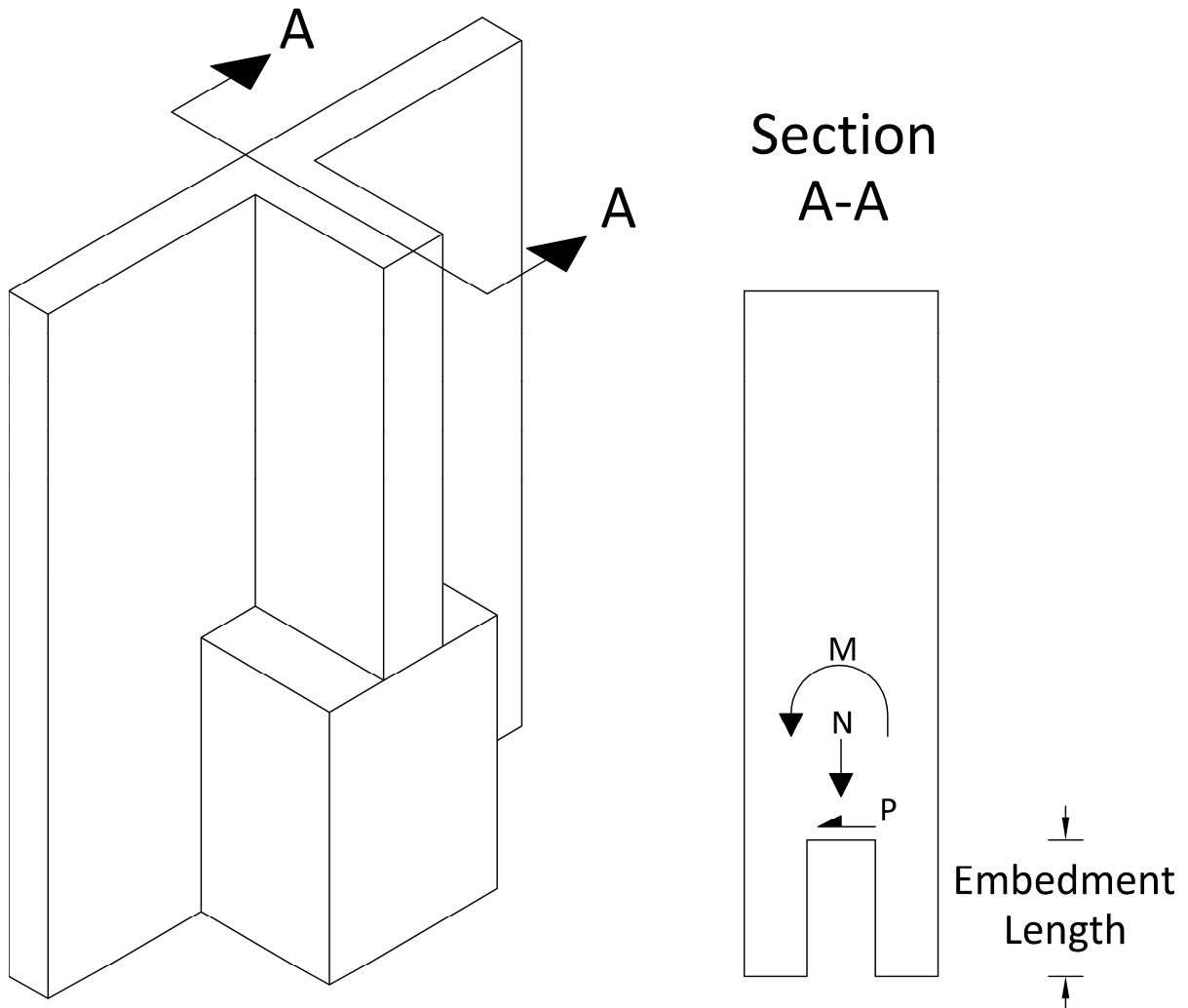

Figure 8-11 – Forces at the top of the pile (right) shown on a limited length socketed wall type abutment

If the axial force is considered separately and the friction forces on the cheeks of the socket are ignored, then only the two unknown compressive forces C_1 and C_2 in Figure 8-12 remain to be determined. Other unknowns are the eccentricities of those forces. In the

analysis the eccentricity for both compressive forces (C_1 and C_2) are assumed as one sixth of the embedment length from the top or bottom of the socket as noted in Figure 8-12⁴⁵. The reactions, C_1 and C_2 , are the only forces that counteract the moment and the shear force caused by earth pressure in this method. After summing all the moments about the point O, the compressive forces can be determined. These results obtained ignoring friction force's contribution to moment resistance are very conservative.

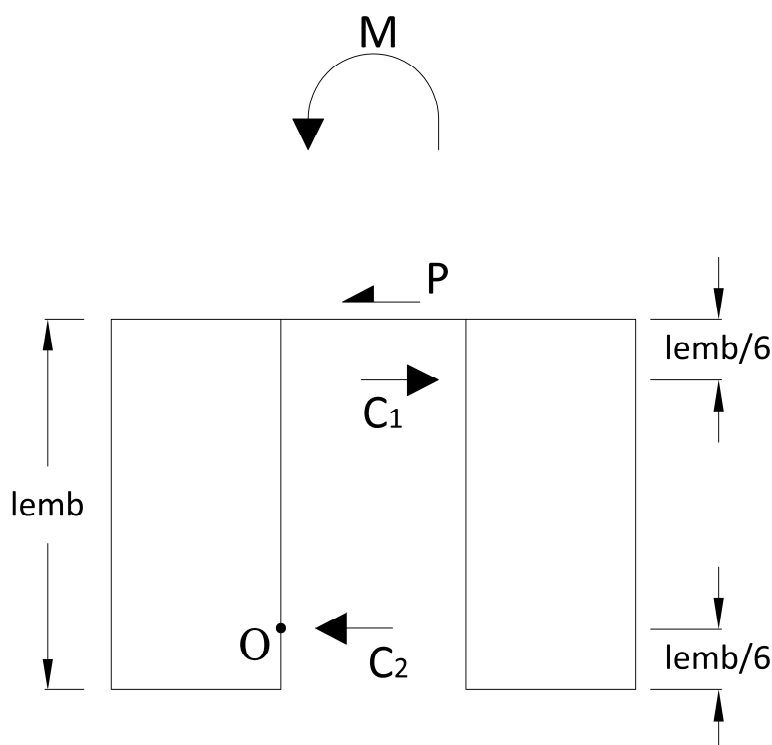

Figure 8-12 – Forces in socket region ignoring friction forces on socket

8.2.5.2 Analysis of Forces Including Friction

Another method of determining forces is to include the contribution of friction forces to moment resistance. When the presence of the friction forces is included in the calculations, they provide an extra moment resistance which, in turn, reduces the other internal design

forces. This approach is similar to a method described by Osanai et.al.⁴⁴. A special method is developed for this study and includes slightly different assumptions. The total model is divided into two sub-models in this case as illustrated in Figure 8-13.

The problem now has additional unknowns: three knowns (M, N and P) and nine other unknowns (C_1 , C_2 , R, F_1 , F_2 , F_3 , e, y and y_1). By dividing the total model into two subsets, six unknowns can be solved directly. The remaining unknowns, eccentricity values, e, y and y_1 have been assumed conservatively by referring to other specifications and research work^{43, 45}.

After determining the three design forces coming from the superstructure and earth pressure, moment is eliminated by replacing it with the shear force moved upwards with an eccentricity of M/P as shown in the middle sketch of Figure 8-13. The reason for this manipulation is to make an assumption that divides both moment and shear force into the sub-models with the same rate.

All the vertical forces are solved in the first sub-model whereas all the friction forces are solved in the second sub-model. Shear force P and compression force C_1 are divided into separate portions (C_{11} and C_{12}) for each model. After solving the first sub-model and finding P_1 , R and C_{11} , these values will be used to solve the second sub-model. For the second part, F_1 and F_3 were related to C_{12} and C_2 with friction coefficient ratios. Since F_1 and F_3 will be the same from the vertical equilibrium, C_{12} and C_2 will also be same. Therefore, after applying all equilibrium equations, unknowns are solved for the whole model.

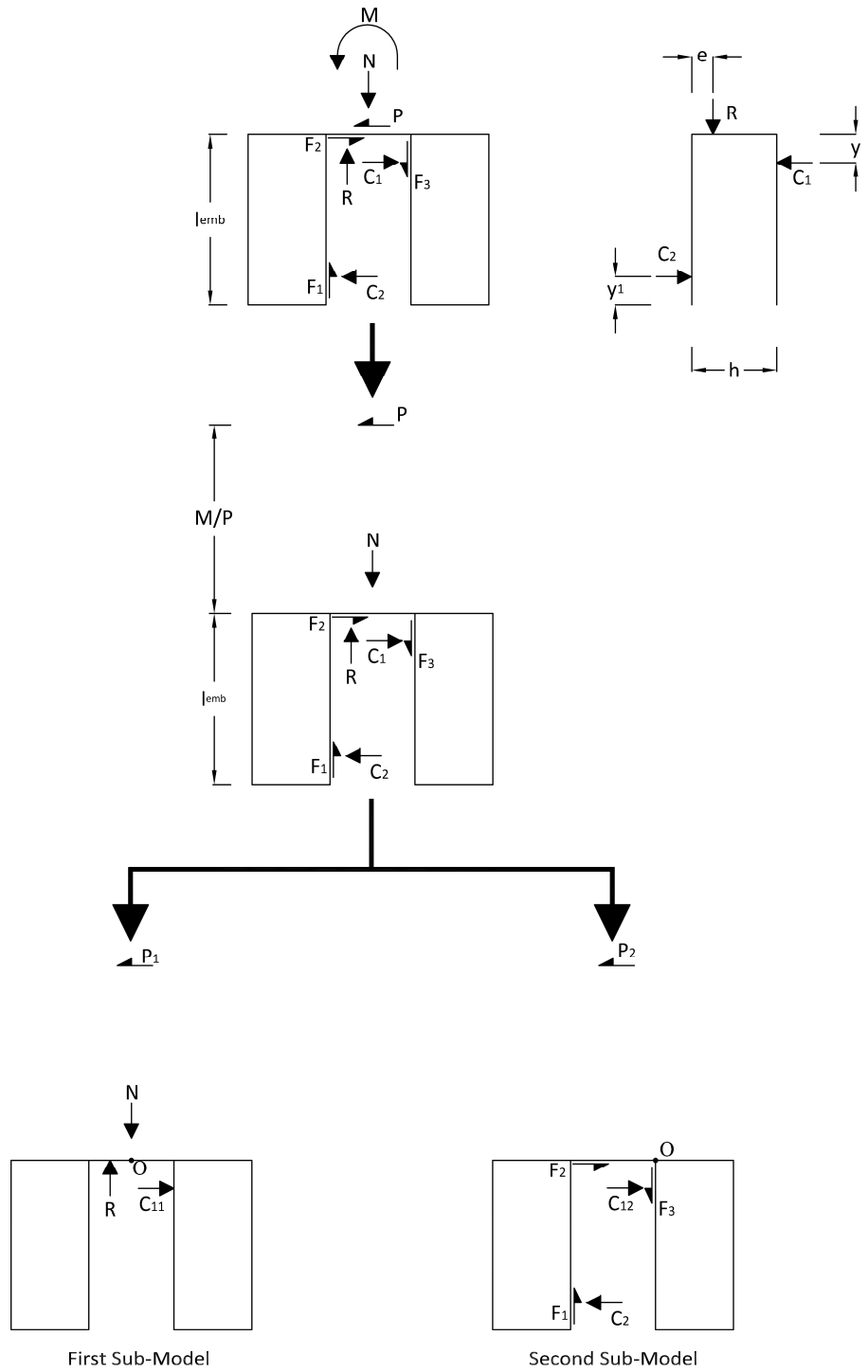

Figure 8-13 – Total model and two sub-models for the case friction is included

8.2.5.3 Design of Socket Region

Once the design forces were found, a unique design approach needed to be developed in this study for providing sufficient strength in the socket region of the wall. The compression forces C_1 and C_2 bearing on the side walls of the socket will be used to design the socket region. An anticipated typical reinforcement layout through the cross section at the abutment socket can be seen at Figure 8-14.

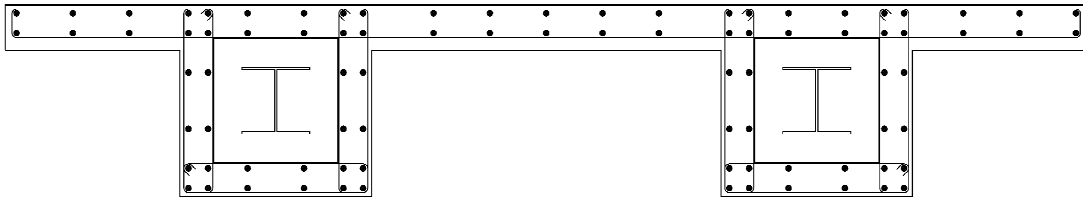

Figure 8-14 – Anticipated reinforcement distribution at the cross section of abutment

The walls of the socket are designated as walls 1, 2, 3, and 4 as labeled in Figure 8-15. Wall 1 and 2 are the transverse walls whereas wall 3 and 4 are parallel walls to the applied forces C_1 & C_2 forces. Wall 2 is part of the abutment wall and wall 1 is outside of the socket.

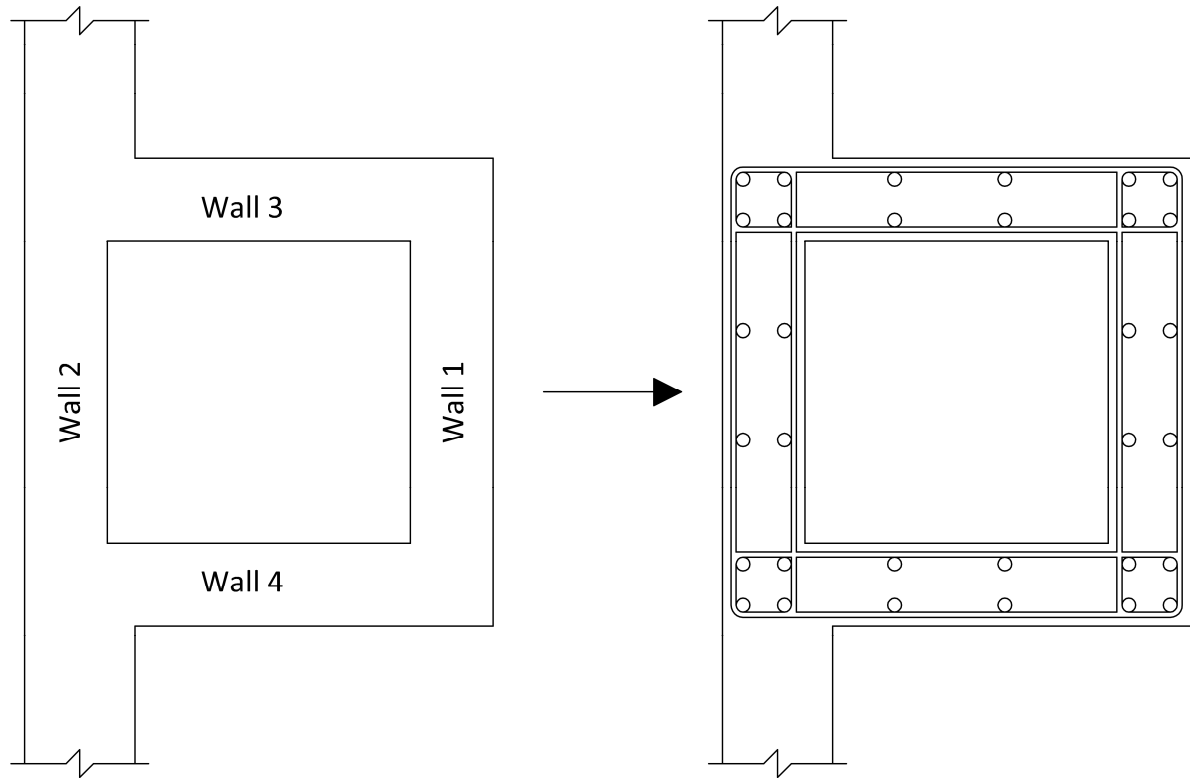

Figure 8-15 – Wall numbers and reinforcement distribution at the cross section of socket region

A resistance concept is needed in the socket design to resist the forces found. Truss action is assumed in the “disturbed” socket region as recommended by AASHTO (LRFD 5.6.3.1). Figure 8-16 shows a vertical cross section through the socket walls 1&2 with the forces C_1 and C_2 and a suggested truss resisting mechanism.

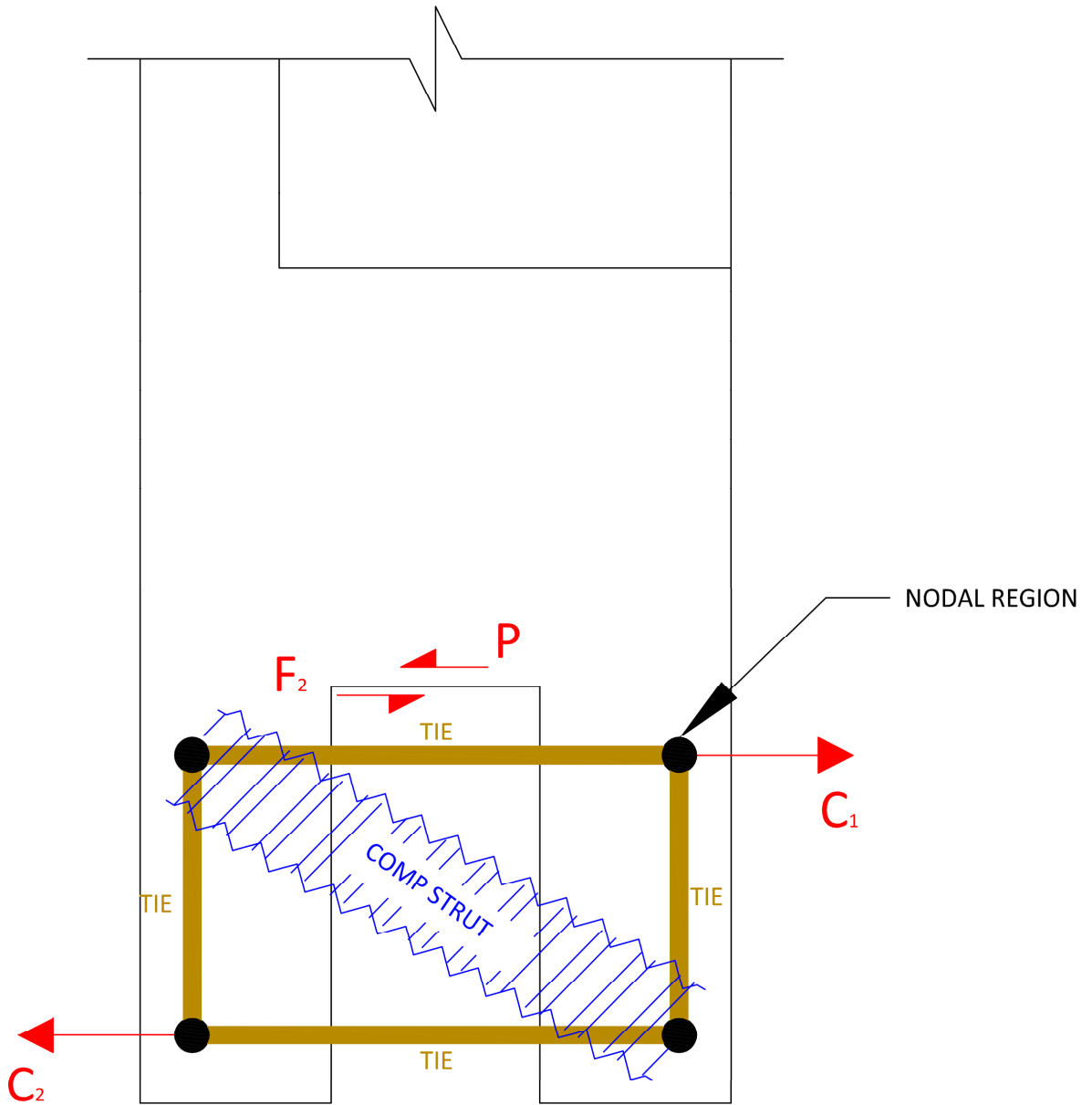

Figure 8-16 – Suggested truss force resisting mechanism in socket region

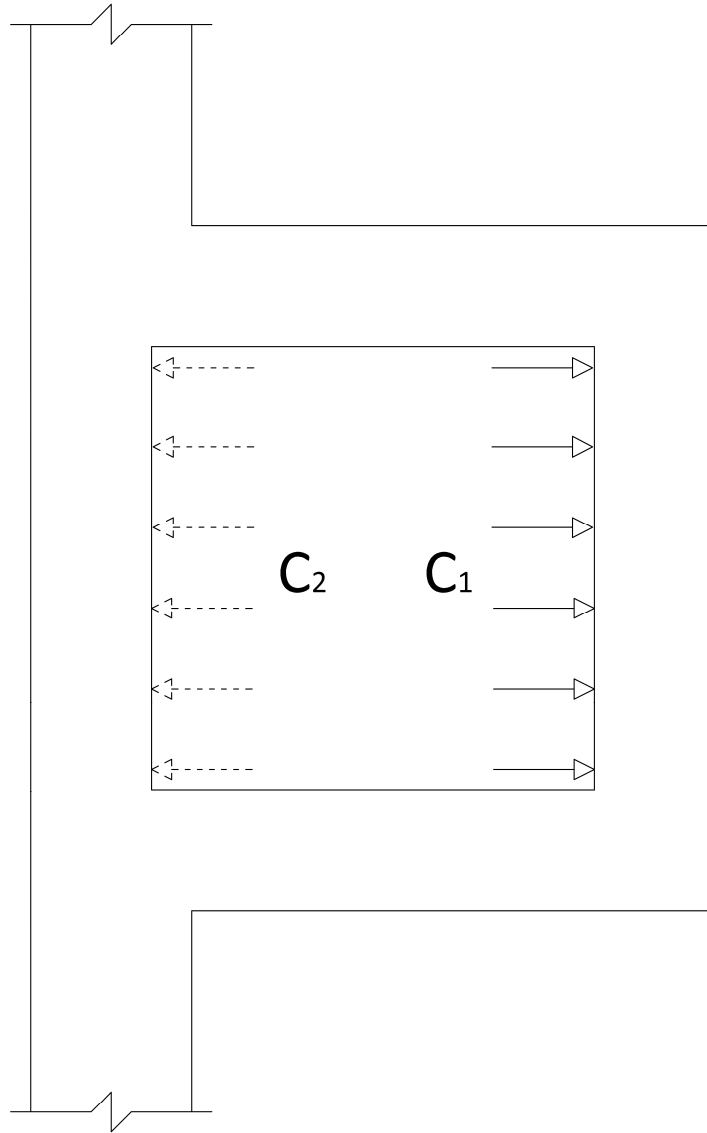

Figure 8-17 – Cross section in plan view of socket region showing the distribution of C_1 and C_2 on walls 1 & 2 respectively

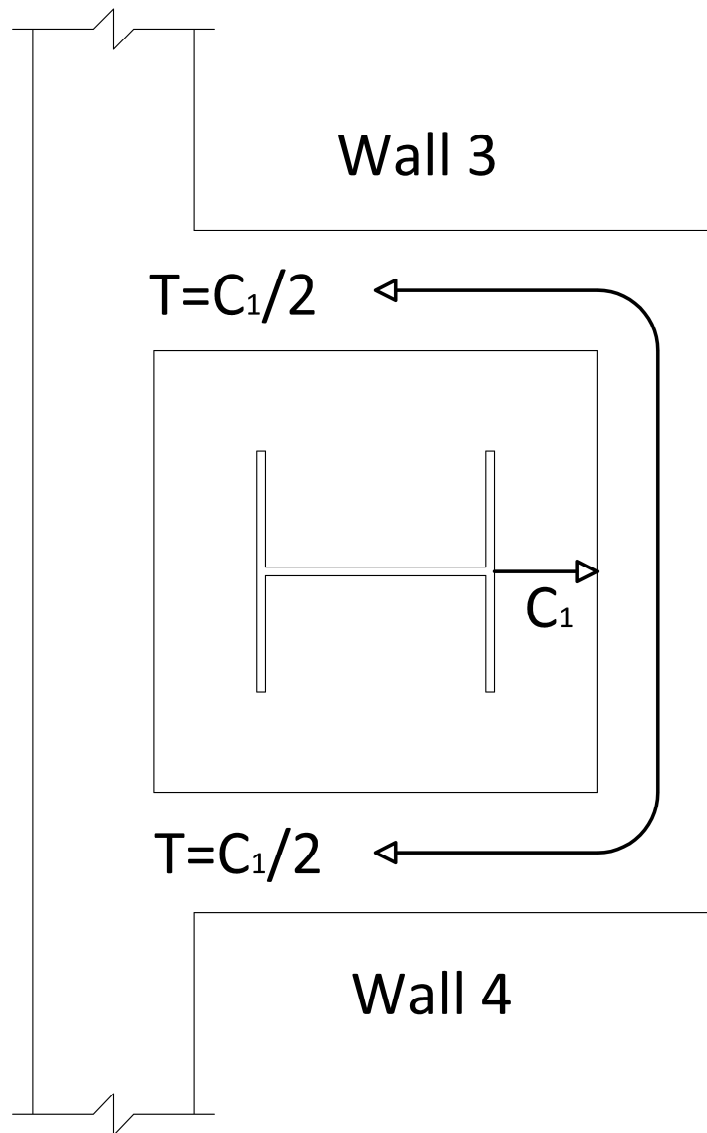

Figure 8-18 – The cross section view showing how C_1 is carried by reinforcements to transverse walls (wall 3 & 4)

For parallel walls (3 & 4) the reinforcement is needed (Figure 8-18):

Tie at top of socket:

C_1 is applied to wall 1 (Figure 8-17, Figure 8-18) and is resisted by tension ties in walls 3 & 4 as shown in Figure 8-18. The required amount of reinforcement to be placed at

the top of the side walls (3&4) is calculated from the T force in each wall. This reinforcement is distributed over the length of $l_{emb}/4$ from the top of the pile (see Figure 8-19), where l_{emb} is the embedment length of the pile in the socket.

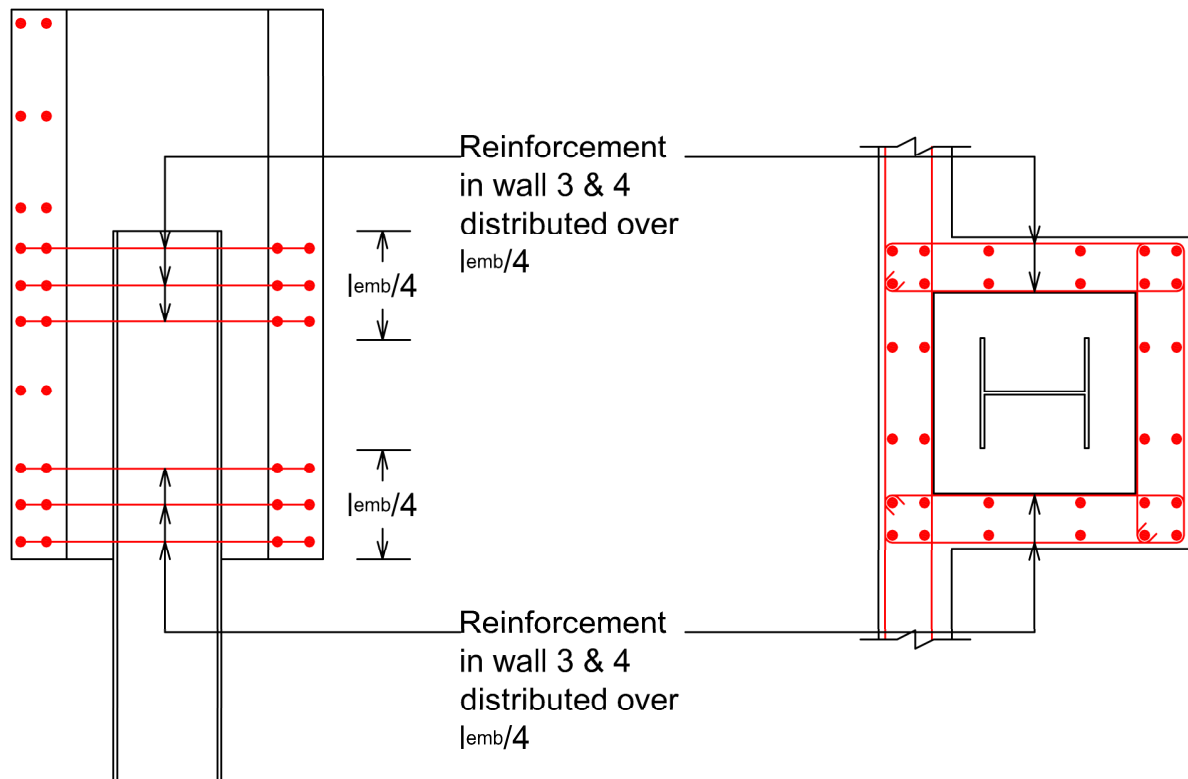

Figure 8-19 – Reinforcement in parallel walls (top and bottom) distributed over $l_{emb}/4$ from top and bottom of the socket

Tie at bottom of socket:

A similar calculation is done for the bottom of the socket but with force $T=C_2/2$ and again the reinforcement is placed in a distance of $l_{emb}/4$ from the bottom of the socket.

For bending of transverse walls 1 & 2, flexural reinforcing:

As shown in Figure 8-17 and 8-20 C1 is distributed over the internal width of the socket. While the load intensity is calculated from the internal socket width, the moments are

conservatively taken for a longer span assuming that the wall 1 spans to the center of walls 3 & 4.⁴³ The bending moments in the socket wall are assumed to be “partially fix ended” since the walls 3 & 4 apply some bending restraint to walls 1 & 2. The assumed end restrained moment diagram is shown at the right in Figure 8-20. The design moments M_1 and M_2 are taken as $WL^2/16$ (vs. $WL^2/12$ at end for fixed ended), since wall 3 and 4 partially restrain the rotation of ends of wall 1. The rotational stiffness is between fixed and pinned joint end conditions. This approach conservatively overestimates the total moment in wall 1 due to the longer span used.

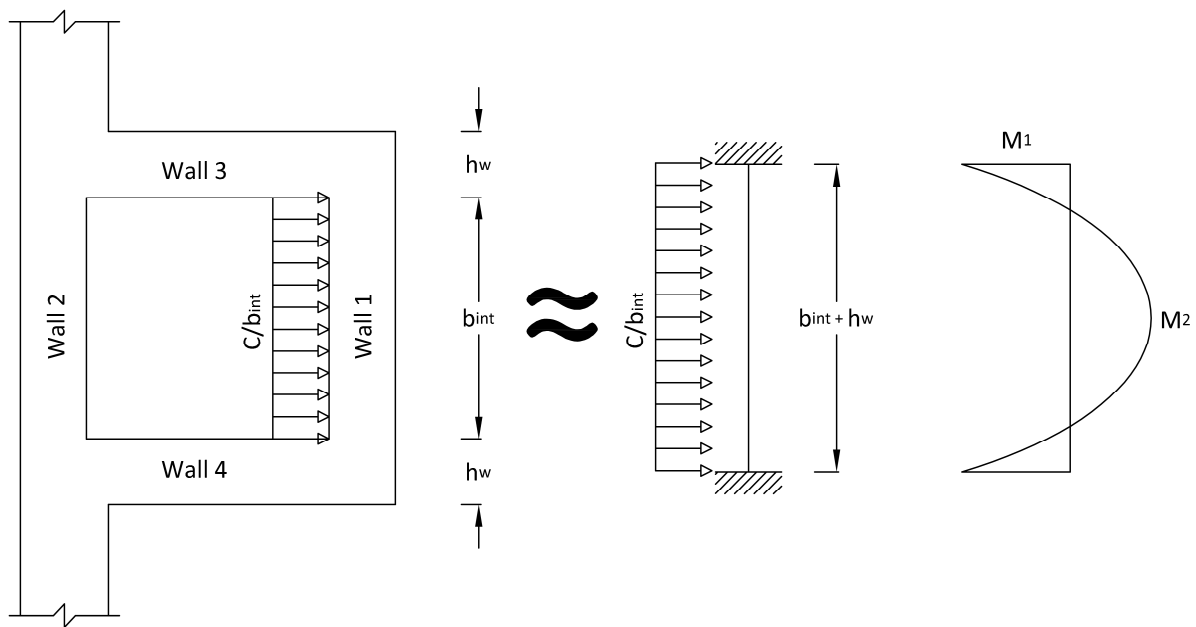

Figure 8-20 – Compression force distribution in socket, the mathematical model and the assumed moment distribution⁴³

The uniformly loaded wall shown in Figure 8-20 will be designed as a “beam” having a depth of h_w (thickness of socket wall) and width (out of paper dimension in Figure 8-20) of the pile embedment length divided by four ($l_{emb}/4$). The flexural design of the “beam” within

the wall will then be the same as normal reinforced concrete beam design. A sufficient reinforcement amount will be determined and spread over the height of $l_{emb}/4$. This procedure is followed for both top and bottom regions where C_1 and C_2 are applied.

Punching failure check for wall 1:

The punching failure design for the socket wall is done according to ACI 318-08.

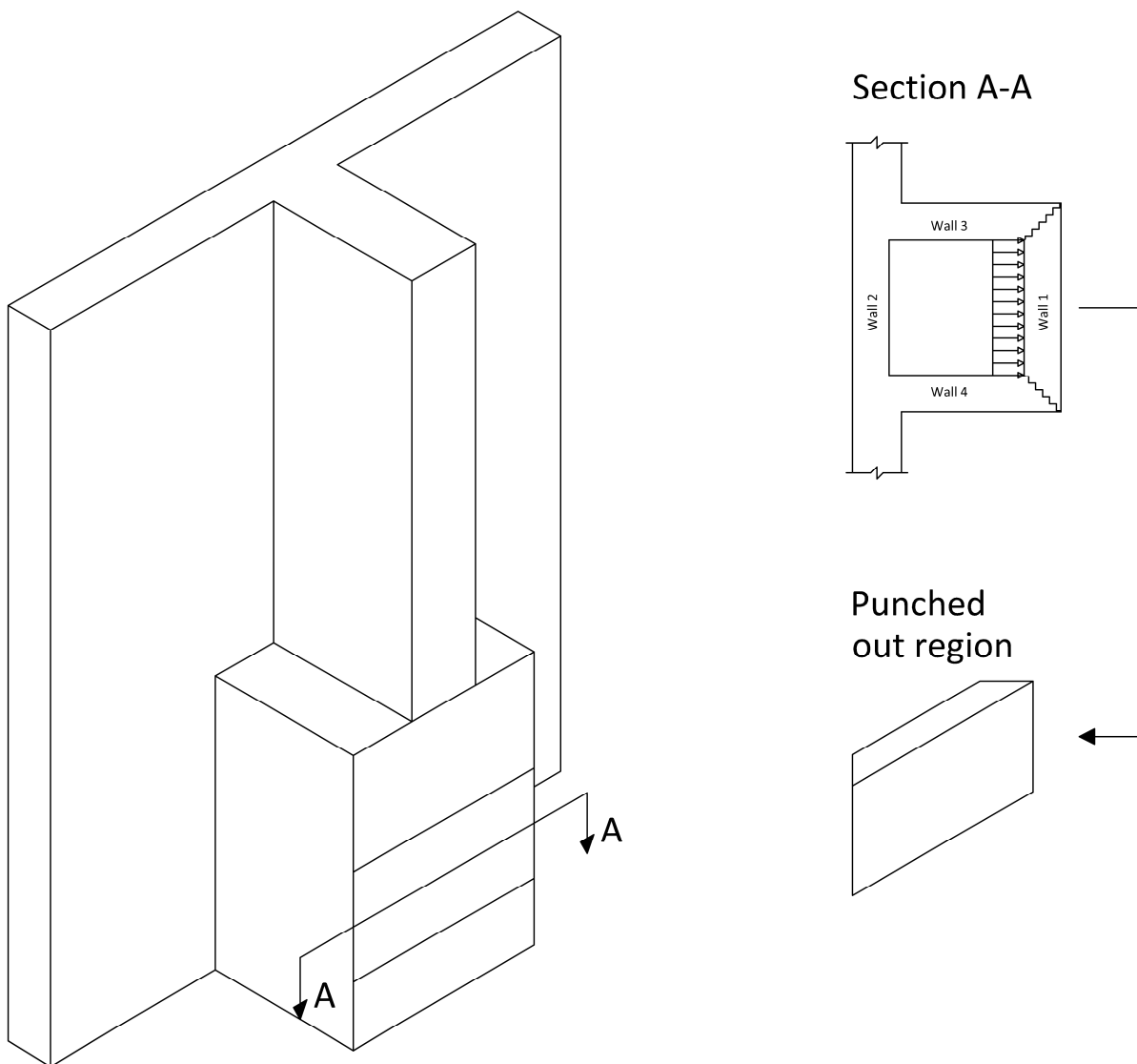

Figure 8-21 – Possible punching failure

When shear failure is considered, the only way that the transverse socket walls can fail is by punching. The punching strength of the concrete section shown in Figure 8-21 is calculated according to ACI 318-08 including the contribution of transverse reinforcements (see Figure 8-22) already in place for flexure. Then the safety of the socket is checked comparing the total strength with the larger of the compression forces C_1 and C_2 .

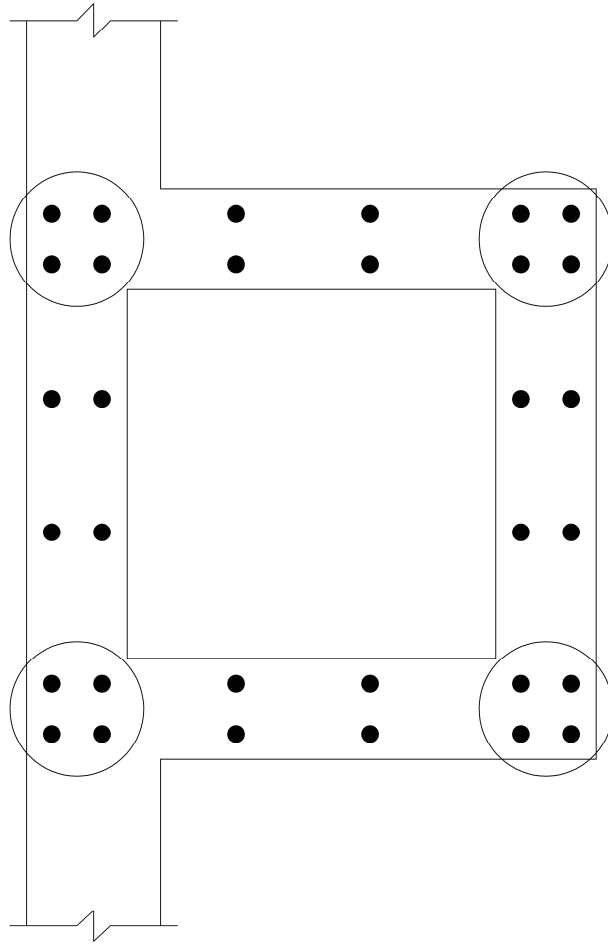

Figure 8-23 – Longitudinal reinforcement at the corners of the socket cross section

At the corner nodes the tension tie forces that are equal to C_1 and C_2 are balanced by the horizontal component of the diagonal. The vertical component of the diagonal (see Figure 8-24) needs to be resisted by vertical (longitudinal) reinforcing, which will create the force F at the wall corners. In order to calculate the required force (F), the angle β of the compression force strut needs to be determined (Figure 8-25). That angle depends on socket dimensions and pile embedment length. It is estimated by assuming the strut-tie is at the middle of the wall thickness. After getting the angle β , the magnitude of force F is found using equilibrium

in horizontal and vertical directions. Then the amount of vertical reinforcement for the tie carrying the force F is determined at the corners of the socket region.

Another important check for this strut-tie design is the capacity of the diagonal compression strut. While determining the force F , the compression force in the strut C_{strut} (Figure 8-24) is also calculated. Therefore the capacity of the strut should be higher than C_{strut} . The determination of the compression capacity of the strut is done according to AASHTO LRFD Section 5.5.4.2.

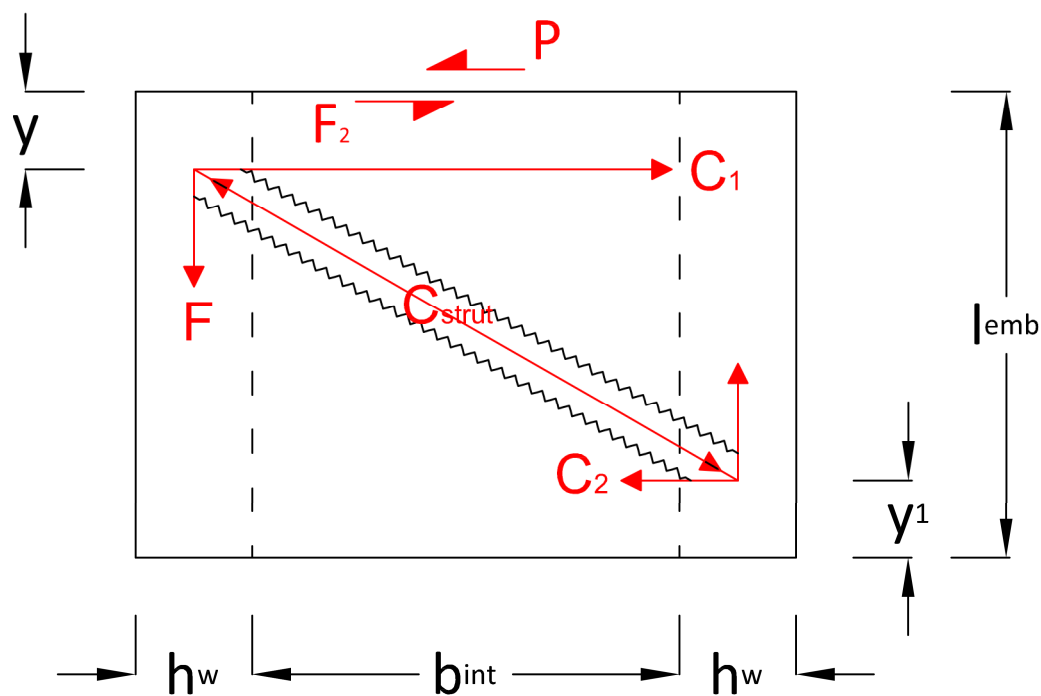

Figure 8-24 – Strut and tie forces in socket

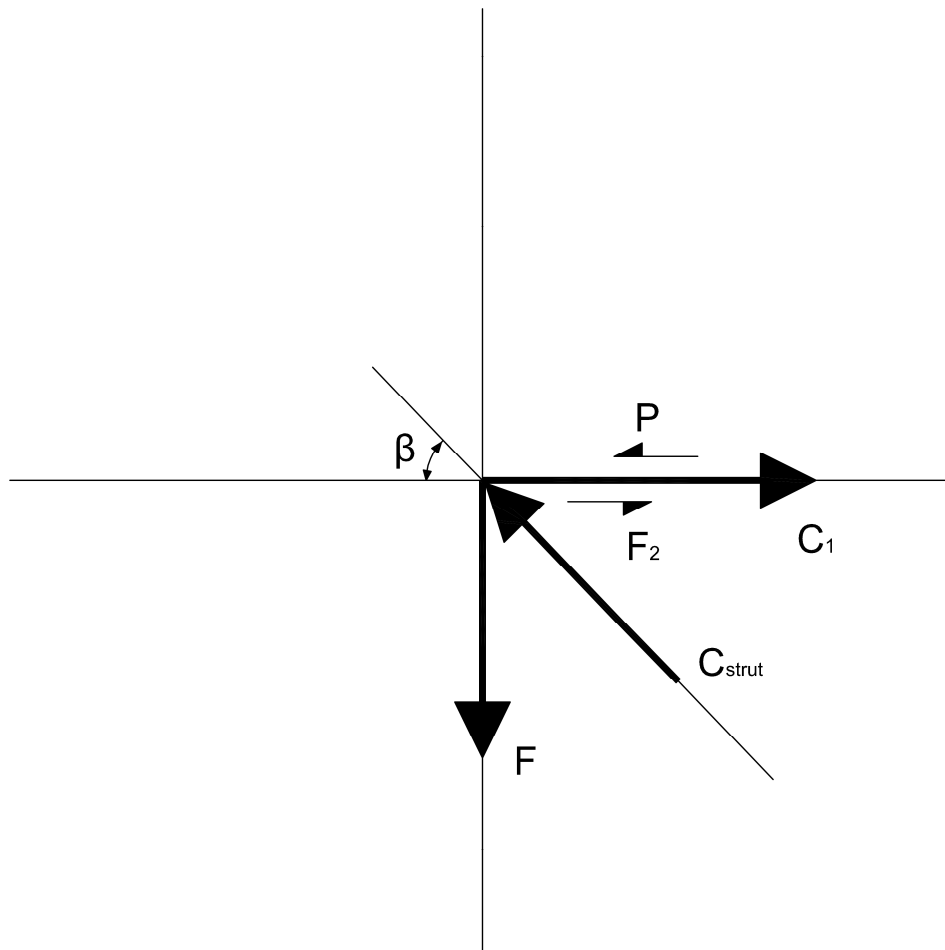

Figure 8-25 – One node of the strut and tie model showing the angle β

8.3 Key Items about New Systems

While developing the new efficient systems, the most important point of consideration was the weight of one module. It was proven after the Baldwin Bridge project that crane capacity is one of the main things that contributes to the overall cost of the precast projects.

The cap system developed in the first phase was decided to be modularized with connections. For that reason, three possible connection systems were proposed and explained in detail with their advantages and disadvantages.

After the Baldwin Bridge experience, it is understood that cast in place emulation for abutments is not a feasible approach for abutments in terms of cost and pace. Therefore, developing new abutment systems with less weight were aimed. Three different abutment systems were developed which harmonizes weight efficiency and constructability with simple connections.

Another important point for the second phase of this project is that the same cap system is intended to be used as pier cap, pile cap, and a shallow abutment system, which will increase the repetitive nature of the project decreasing the cost. It will also allow precasters to use the same formwork repetitively.

In this study, MathCad sheets were also developed that do all the calculations for design force determination, socket design with comprehensive commentary as a tutorial. Another short version of the socket design sheet was also created to be used by design engineers in detailing socket reinforcing.

Chapter 9: Conclusions and Recommendations

A series of precast substructure systems for highway bridges, including abutments and pier/pile caps, have been described. These systems were selected to create a system of substructure components for standardization by a transportation agency. These particular systems were selected to achieve:

- Lightweight and manageable sizes
- Repetitive shapes and formwork
- Simple connections and assembly

Abutments for different bridges may differ in terms of pile spacing and height. For standardization the abutments could be categorized into two groups with different height intervals: a 3ft height for applications that need 3ft-6ft abutments and a 7ft height for abutments between 6ft-10ft. Recall that the actual height of the abutment is the height of the abutment segment plus the height of the bent cap which will be placed on top.

For very short abutments, less than 3-4ft in height, a standard pier/pile bent cap will be used in place of an abutment with connection to the pier/pile through reinforcement in the cap pockets.

For the first height interval, which is 3ft-6ft, full length socketed walls (Figure 9-2) are preferred. Embedment length is variable for the piles embedded into sockets, but it is advised to use a minimum of 2ft embedment length.

The limited length socketed wall (Figure 9-3) should be used for the height interval of 6ft-10ft. The total socket length is a fixed at a value which is 4ft. Therefore, embedment length of the piles is to be between 2ft-3ft.

Another idea about modularization is that the selected abutment segments can be produced in the factory with 5ft (1.5m) fixed pile spacing and variable cantilever walls on each side of the module as shown in Figure 9-1 to meet width requirements for the bridge. This would require adjustable forms on the sides of the module formwork. It is important, however, that the pile spacing within a module be held constant because adjusting the location of the sockets in a form system would be difficult. A less attractive alternative would be to have fixed length and adjustable height.

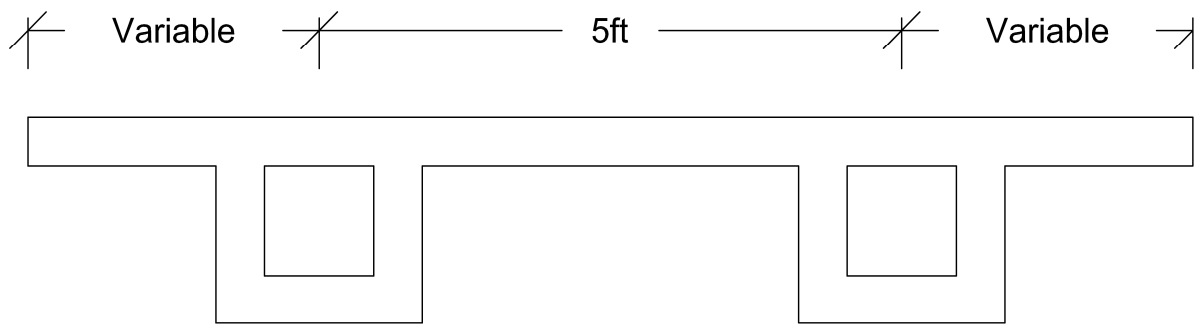

Figure 9-1 – Cross section view of abutment section which shows the fixed pile spacing, fixed heights of 3ft or 7ft, and variable overall length

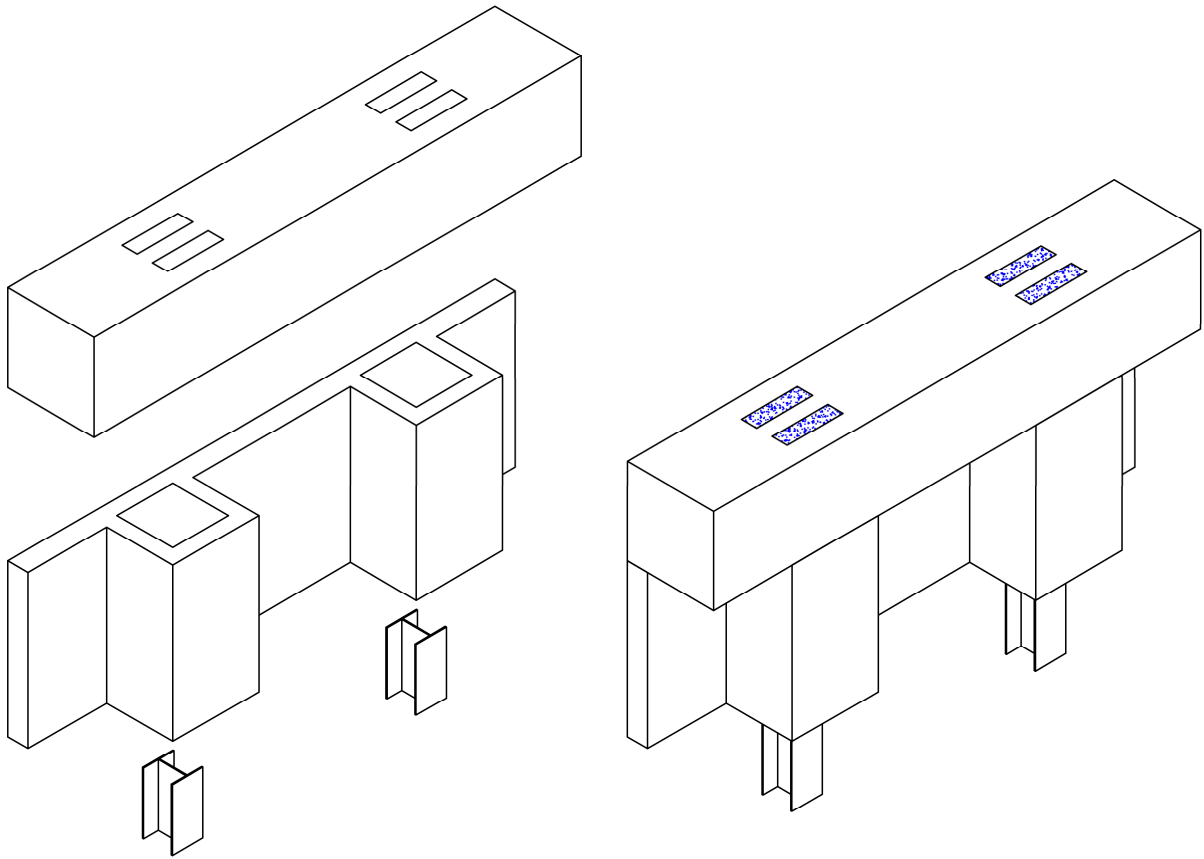

Figure 9-2 – Full length socketed wall abutment type with bent cap

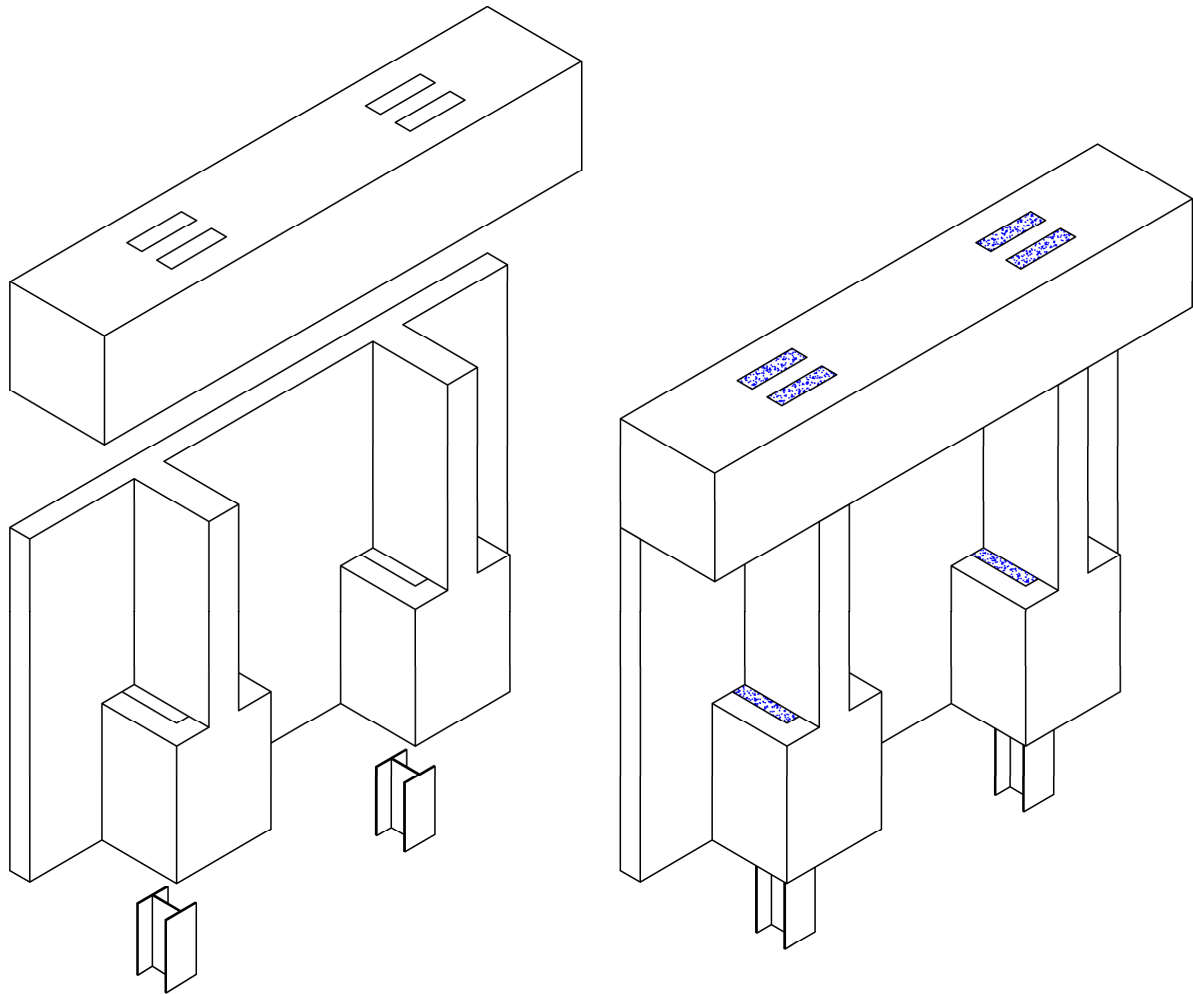

Figure 9-3 – Limited length socketed wall abutment type with bent cap

In the design example which is provided in appendices, 2ft of embedment length was used and the design proceeded accordingly. Since the lateral loads are getting higher with a taller wall, the thickness of the socket wall should be determined with regard to punching shear failure. The socket region will be grouted to get a rigid connection between pile and abutment body. The connection between bent cap and the limited length abutment body will be performed with reinforcements which are drilled into the vertical strut region of the abutment. After positioning the reinforcements in block outs of the bent cap, the pocket will

be grouted as well. Reinforcements may also be put into abutment segment at the factory during production without the hassle of drilling them on site.

A post-tensioned connection is chosen as the primary connection system between pier or pile bent cap modules. Other types, welded or spliced reinforcing bars, may be alternative connections but may require alterations to standard formwork which is not desirable. WisDOT is encouraged to use post-tensioning technology for as a standard for connecting multiple modules of precast pier bent caps.

The systems explained in detail in this thesis are intended to be used in non-seismic regions. The requirements for seismic region structures were not checked or satisfied while developing abutment types and bent cap types. But, there are current researchers which elaborate on seismic capacity of these precast systems and connections.^{47, 48, 49} It is believed that codes and requirements for precast substructure systems for seismic regions will be developed in near future and will be used widely all around the country. This will ensure that usage of precast concrete for bridge substructures will not be limited to non-seismic areas.

The modules used in Baldwin Bridge had 10ft. height and 11ft. length; therefore, the weights of the developed components with the same dimensions have been compared:

- Baldwin Bridge module = 33k
- Full length option = 24.67k (25% weight reduction)
- Limited length option = 21k (36% weight reduction)

Since all the design calculations are based on 8ft of pile spacing which is the maximum pile spacing allowed by WisDOT Bridge Manual, the length of the module comes out to be 16ft. Therefore, weight comparisons for 16ft long abutments are also done.

- Actual module (Baldwin) = 51.75k
- Full length option = 29.67k (43% weight reduction)
- Limited length option = 26k (50% weight reduction)

Therefore, as the length of the module increases, the weight efficiency also increases since the socket region dimensions are remained pretty much same. During the Baldwin Bridge construction, contractor required to use a larger capacity crane than the crane that they use for that type of bridge. This created the problem the difficulty of moving the big crane from one side of the bridge to other side and big crane usage increased the overall cost of the bridge project as well. This is the main driving force towards the desire to have low weight abutment modules. Using smaller and more panels to decrease the panel weight would allow a smaller crane, but adds to the number of joints and to the construction time. Therefore, the lengthy but lightweight modules are necessitated for this project.

Another important point is that there were not many examples of steel HP pile socketed connection in literature. Therefore, we needed to come up with methods for force determination and design for socket region. This is done taking the older studies and other specifications as guidance. All the design sheets are attached in the appendices section.

The time savings from the precast abutment system is also expected to be substantial and prevent long term detours. The Baldwin Bridge abutments required 60 man-hours of general laborers with 15 man-hours of crane operator. Therefore, the pace of the similar project with new abutment systems is expected to be close to the Baldwin Bridge. On the other hand, similar cast in place abutment requires at least two weeks for construction and one week of curing before superstructure erection can be started.

In this project, an estimate cost for the developed systems was going to be given but engineers from precaster companies could not be reached. Due to the lack of communication, the information about the easiness, constructability, and the cost of abutment systems are not given here.

With the motivation of seeing successful accelerated bridge construction projects completed throughout the US, the end products of this project, precast cap and abutment systems, will hopefully help Wisconsin in reducing construction time, reducing effects to public and building innovative bridges. Author strongly recommends and expects usage of precast concrete systems for substructures not only for ordinary bridge construction but also for especially replacement projects in Wisconsin. Bridge constructions using the systems developed in this study are expected to be built in Wisconsin in the near future.

References

1. US FHWA. “Deficient Bridges by State and Highway System - Programs - Integrated - Bridge - FHWA.” *Deficient Bridges by State and Highway System*, n.d.
<http://www.fhwa.dot.gov/bridge/nbi/defbr09.cfm>.
2. WisDOT. “Wisconsin Department of Transportation, Bridges,” n.d.
<http://www.dot.wisconsin.gov/projects/bridges/>.
3. Shahawy, Mohsen A. *Prefabricated Bridge Elements and Systems to Limit Traffic Disruption During Construction*. Washington D.C.: National cooperative Highway Research Program, 2003.
4. Stamnas, Peter E., and Mark D. Whittemore. “All Precast Substructure Accelerates Construction of Prestressed Concrete Bridge in New Hampshire.” *PCI Journal* (2005).
5. *Guidelines for Accelerated Bridge Construction Using Precast/Prestressed Concrete Components*. Belmont, MA: PCI Northeast, 2006.
6. PCI. “PCI Bridge Design Manual.” In *Additional Bridge Products*, n.d.
7. Arsoy, S., J. M. Duncan, and R. M. Barker. “Performance of Piles Supporting Integral Bridges.” *Transportation Research Board of the National Academies* 1808, no. 1 (2002).
8. Burdette, Edwin G., Samuel G. Howard, J. Brandon Tidwell, Edward P. Wasserman, Earl E. Ingram, J. Harold Deatherage, and David W. Goodpasture. “Lateral Load Tests on Prestressed Concrete Piles Supporting Integral Abutments.” *PCI Journal* (2004).
9. Wolfe, Raymond W., Paul Chung, and Anahid Dermegerdician. “Accelerating Bridge Construction-Precast Abutment Solutions.” Phoenix, Arizona, 2007.

10. Benoit, Nathaniel D., Eric T. Calderwood, Jr Wayne L. Frankhauser, Dennis R. Hanson, Kenneth R. Heil, and Jeffrey J. Tweedie. "Instant Bridge - Just Add Water." Palm Springs, CA, 2005.
11. Merwin, Donald. "Case Study: Prestressed Concrete Bridge Built in One Weekend." *PCI Ascent Magazine*, 2003.
12. Huh, Ben P., and John P. Low. "Moose Creek Bridge, the First Field Application of Fully Prefabricated Bridges in Ontario." Atlanta, GA, 2004.
13. Hohmann, David P., Michael D. Hyzak, Clark R. Slacum, and Lloyd M. Wolf. "Rapid Bridge Replacement Project for the Tanglewood Bridge." Atlanta, GA, 2004.
14. Abu-Hawash, Ahmad, Norman L. McDonald, James S. Nelson, Stuart Nielsen, and Anthony Samuelson. "Accelerated Construction in Iowa." Phoenix, Arizona, 2007.
15. M., Iqbal Asif. "Davis Narrows Bridge in Brooksville, Maine: Fast Track Solution to an Environmentally Sensitive and Tourist Location." Committee, the PCI Northeast Bridge technical, 2006.
16. "Prefabricated Bridge Elements and Systems." *FHWA website*, 2008.
17. Scanlon, Andrew, Alex Aswad, and James Stellar. "Precast posttensioned abutment system and precast superstructure for rapid on-site construction." *Transportation Research Record*, no. 1814 (2002): 65-71.
18. Crawford, Jeremy A., Harivadan Parikh, and Joseph A. Thompson. "Accelerated Replacement of a Three Span Bridge in Pennsylvania." Grapevine, Texas, 2006.
19. "PCI Bridge Design Manual." In *Prestressed Concrete Bridges, the High Performance Solution*. PCI, n.d.

20. Lesbros, Luis Felipe Cruz, Carranza Rene Aubry, and Eduardo Reunoso Angulo. "Design and Construction of the Ayuntamiento 2000 Bridge, Cuernavaca, Mexico." *PCI Journal* (2003).
21. "Post-tensioning in Florida Bridges." In *New Directions for Florida Post-Tensioned Bridges*. Tallahassee: Florida Department of Transportation, 2002.
22. Corven, John, and Alan Moreton. *Post-tensioning Tendon Installation and Grouting Manual*. US Department of Transportation, Federal Highway Administration, 2004.
23. Denney, Pate. "The Chesapeake and Delaware Canal Bridge - Design-Construction Highlights." *PCI Journal* (1995).
24. Billington, Sarah, Robert Barnes, and John Breen. *A Precast Substructure Design for Standard Bridge Systems*. Texas: Center of Transportation Research, University of Texas Austin, September 1998.
25. Medlock, Ronnie, Michael Hyzak, and Lloyd Wolf. "Innovative Prefabrication in Texas Bridges" (n.d.).
26. Billington, S. L., R. W. Barnes, and J. E. Breen. "Alternate Substructure Systems for Standard Highway Bridges" (2001).
27. Leonard, Michael. "Accelerated Bridge Replacement in a Rural Environment." Baltimore, Maryland, 2008.
28. Asnaashari, Ali, Jon R. Grafton, and Johnnie Mark. "Precast Concrete Design-Construction of San Mateo - Hayward Bridge Widening Project" (2005).

29. Matsumoto, E. E., M. C. Waggoner, G. Sumen, M. E. Kreger, S. L. Wood, and J. E. Breen. *Development of a Precast Bent Cap System*. Texas: Center of Transportation Research. The University of Texas Austin, January 2001.
30. Wolf, Lloyd M. "Texas DOT Experience with Prefabricated Bridge Construction." MCEER Professional Development Seminar: Accelerated Bridge Construction, 2005.
31. Josten, Mark G., Wilfred L. Painter, and James S. Guarre. "Precast Prestressed Concrete Structure Provides Solution for Getty Center Tram Guideway." *PCI Journal* (1995).
32. Ray, M. Trujillo. "New Mexico's 32 Day Bridge." Palm Springs, CA, 2005.
33. Blakemore, Frank P., Travis F. Konda, Cyrus Morrow, and S. L. Kaderbek. "Design / Build of US-90 Replacement Bridge over St. Louis Bay." Phoenix, Arizona, 2007.
34. Theobald, Don. "Rapid Bridge Replacement with Prestressed Piles and Pile Caps." In *the PCI National Bridge Conference*, 2007.
35. Splice Sleeve North America, Inc. "Edison Bridge, Fort Myers, Florida." *Construction Data Sheet*, 1999.
36. "Highway Structures Information - Structure Costs." *Wisconsin Department of Transportation, Bureau of Structures Web Site*, n.d. https://trust.dot.state.wi.us/extntgtwy/dtid_bos/extranet/structures/english-details.htm.
37. "Project Of The Month: October 2006 - CPCI - Canadian Precast Prestressed Concrete Institute www.cpci.ca," n.d. <http://www.cpci.ca/?sc=potm&pn=monthly102006>.
38. Matsumoto, Eric E., Michael E. Kreger, Mark C. Waggoner, and Guclu Sumen. "Grouted connection tests in development of precast bent cap system." *Transportation Research Record*, no. 1814 (2002): 55-64.

39. McMinimee, James C., and Carmen Swanwick. "An Owner's Perspective on Implementing an Accelerated Bridge Construction Program." Baltimore, Maryland, 2008.
40. Lewllyn, Matthew W. "Accelerated Bridge Construction for a Low Volume, Rural Bridge." Orlando: FHWA Bridge Engineering Conference, 2010.
41. "UDOT Accelerated Bridge Construction." *Utah Department of Transportation*, n.d. <http://udot.utah.gov/main/f?p=100:pg:0:::1:T,V:1991>.
42. Campbell, Bruce L. "A Precast Bridge System for Rapid Construction Applications." Orlando: FHWA Bridge Engineering Conference, 2010.
43. Canha, Rejane Martins Fernandes, Kenneth de Borja Jaguaribe Jr., Ana Lucia Homce de Cresce El Debs, and Mounir Khalil El Debs. "Analysis of the behavior of transverse walls of socket base connections." *Engineering Structures* 31, no. 3 (2009): 788 - 798.
44. Osanai, Yutaka, Fumio Watanabe, and Shin Okamoto. "Stress transfer mechanism of socket base connections with precast concrete columns." *ACI Structural Journal* 93, no. 3 (1996): 266 - 276.
45. "TS 9967 - Design Construction and Erection Methods for Precast Reinforced and Prestressed Concrete Elements Structures and Buildings." Turkish Standad Institute (TSE), March 1992.
46. Okumus, Pinar. "Rapid Bridge Construction Technology: Precast Elements for Substructures." Madison, WI: University of Wisconsin - Madison, 2008.
47. "TRB Webinar on "Development of a Precast Bent Cap System for Seismic Regions"." Transportation Research Board, 2010.

48. Stanton, John F., and Marc O. Eberhard. "Rapid Construction of Bridges with Deep Foundations," June 2011.
49. Steuck, Kyle P., Marc O. Eberhard, and John F. Stanton. "Anchorage of large-diameter reinforcing bars in ducts." *ACI Structural Journal* 106, no. 4 (2009): 506-513.

Chapter 10: Appendices

- New Design Example Sheets
 - Socket Region Design Sheet
 - Abutment Design Sheet
 - Load Calculation Sheet for Abutment Design
 - Load Calculation Sheet for Bent Cap
 - Pier Bent Cap Design Sheet
 - Post-tensioned Connection for Bent Caps
 - Spliced Reinforcement Connection for Bent Caps
 - Welded Steel Plate Connection for Bent Caps
- Preliminary Design Example Sheets (1st Phase)
 - Preliminary Abutment Design Example
 - Preliminary Pier Cap Design Example
- Standard Drawings
 - Selected Abutment System I Drawing
 - Selected Abutment System II Drawing
 - Alternative Abutment System Drawing
 - Spliced Reinforcement Connection for Bent Caps
 - Welded Steel Plate Connection for Bent Caps

Design Examples

Socket Region Design Sheet

Users Guide:

- What does program do?

This design sheet shows the design of socket region in which steel HP pile is inserted.

- What input is required?

Dimensions:	l_{emb}	: Embedment length of pile in socket
	e	: Eccentricity of axial force on pile
	y	: Assumed eccentricity for C_1
	y_1	: Assumed eccentricity for C_2
		(see Figure 2 for eccentricities e , y and y_1)
	h	: Depth of steel HP pile
	b_{int}	: Inner dimension of the socket
	h_w	: Thickness of the socket wall
Material properties:	f_c	: Strength of the concrete
	f_y	: Yield strength of steel
	E_s	: Modulus of elasticity of steel
Loads:	M	: Factored design moment at top of pile
	N	: Factored axial design force at top of pile
	P	: Factored design shear force at top of pile
Resistance factors:	Φ_F	: Resistance factor for flexure
	Φ_{punc}	: Resistance factor for shear from ACI
	Φ_T	: Resistance factor for strut-tie tension member
	Φ_c	: Resistance factor for strut-tie compression member
Design parameters:	N	: Reinforcement bar size
	n	: Number of reinforcement bars
	α	: Coefficient of friction between steel and concrete
	$cover_{int}$: Socket region interior cover to main reinforcing
	$cover_{ext}$: Socket region exterior cover to main reinforcing

- What is the output?

The checks which verify whether the entered amount of reinforcement is enough or not are the outputs of this sheet. When all the checks are okay, we make sure that our design is completed.

Reference Manual:

- How calculations are done?
Procedures followed are described step by step in detail while calculations are done.
- Example design problem is shown below with sample input/output.

Description of Forces:

There are two primary loads applied on abutment bodies, which are horizontal and vertical forces. These loads must be estimated prior to design. Horizontal loads are divided into horizontal earth pressure caused by fill and live load surcharge from vehicles. Earth pressure loads from fill have a triangular distribution on the back face, zero at the top and largest at the bottom assuming active conditions. While calculating this type of pressure behind the abutment wall, we use Equivalent-Fluid Method of Estimating Rankine Lateral Earth Pressures explained in LRFD 3.11.5.5. Please note also that this method can only be applied when we have free draining backfill. Here, we assume that drainage methods will be applied at the site to lower the water table behind the wall and this will keep the soil behind the wall drained all the time. Horizontal loading due to live load surcharge from vehicular wheel load is assumed to create a constant horizontal earth pressure. The constant pressure is calculated as the multiplication of the coefficient of lateral earth pressure (active conditions apply), unit weight of soil and equivalent height of soil for vehicular load. This equivalent height has been tabulated for designers in AASHTO to pick up the right value for a case. Linear interpolation between heights is also allowed.

In addition to horizontal loads, we have vertical loads which are coming from the superstructure as dead load and live load. In the design examples, vertical loads are assumed. In order to be precise, all the dimensions of the bridge should be known so that the exact dead load can be calculated and the total factored dead load is calculated.

Discussion of Two Methods:

The abutment is connected to piles through sockets. There are two concepts that can be used to determine the forces inside of the socket region. They are models with friction and without friction. The most common method is to find resisting forces ignoring friction inside of the socket region. By doing so, we ignore the contribution of the friction forces to resisting moment and we increase the compressive design forces. On the other hand, when we include the presence of the friction forces in our calculations, we have the extra resisting moment coming from those frictions which, in turn, reduces other design forces. That is because the required moment capacity from compressive forces is lower than the case when we ignore frictions. Total model is divided into two submodels and then analyzed separately to get the forces. This method is similar to Osanai, Y., Watanabe, F., Okamoto, S. (1996). Stress transfer mechanism of socket base connections with precast concrete columns. ACI Structural Journal, v 93, n 3, p 266-276

Figure 1 shows a model without friction and Figure 2 shows the model with friction and how it is divided into two submodels.

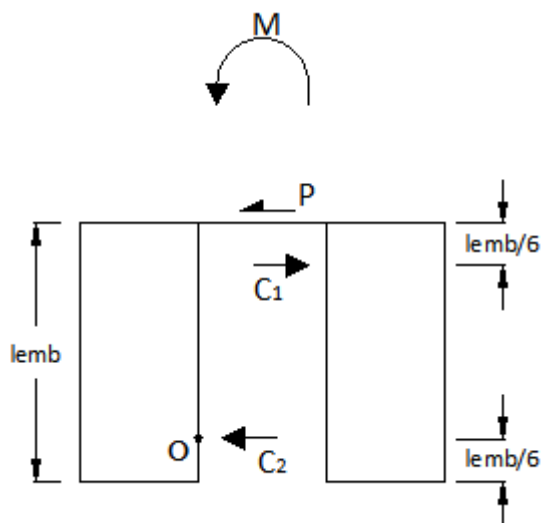

Figure 1
Ignoring Friction

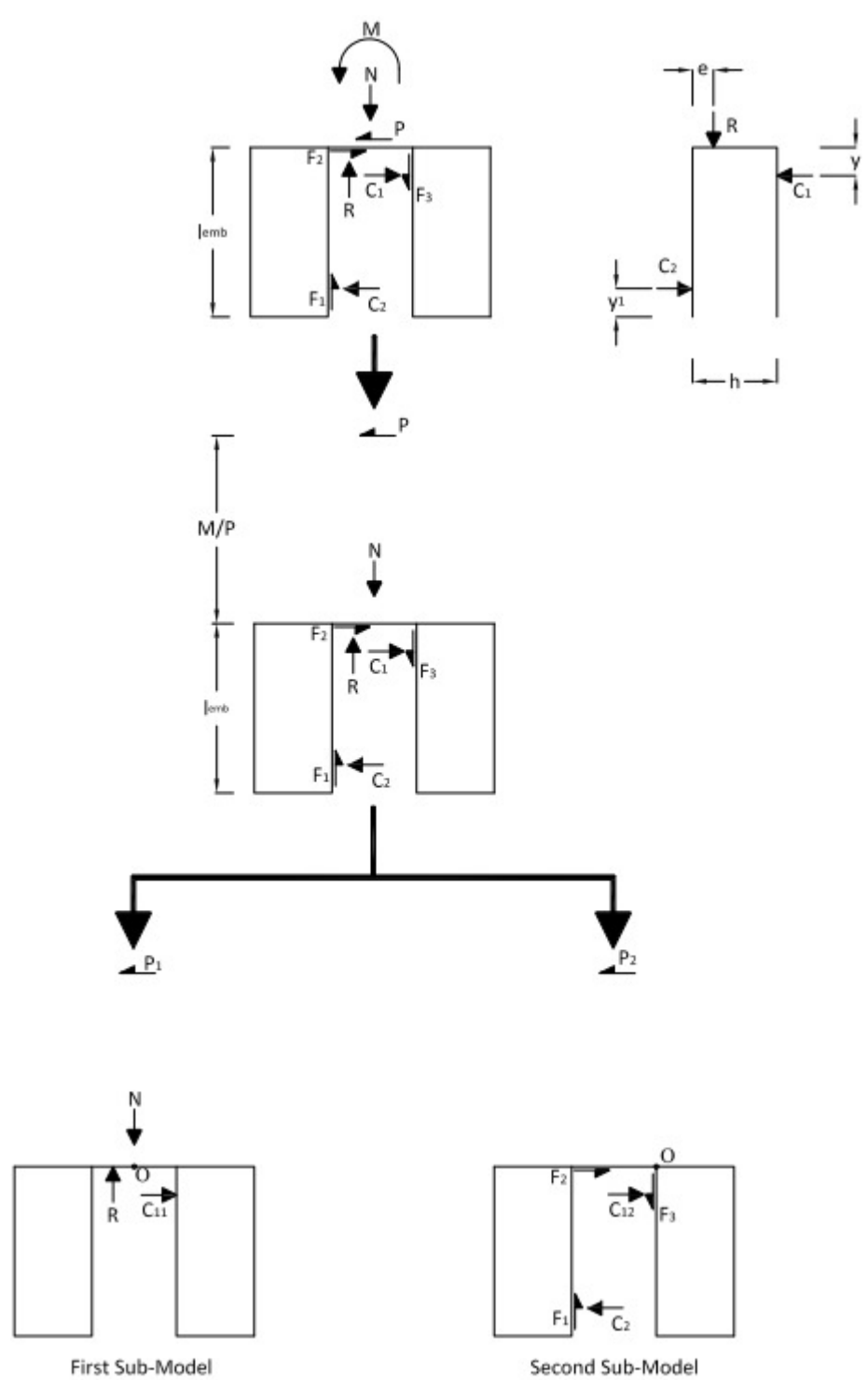

Figure 2
Including Friction
Resistance

All inputs are in red color.

All checks are in yellow color.

Friction Forces Included:

Design Constants:

$$M := 125 \text{ kip}\cdot\text{ft}$$

factored moment at top of pile from applied loads

$$N := 145 \text{ kip}$$

factored axial force at top of pile from applied loads

$$P := 37 \text{ kip}$$

factored shear force at top of pile (from lateral soil pressure)

$$h := 12 \text{ in}$$

depth of steel HP pile

$$l_{\text{emb}} := 2 \text{ ft}$$

embedment length of pile in socket

$$e := \frac{h}{4} = 3 \cdot \text{in}$$

eccentricity of axial force on pile

$$y := \frac{l_{\text{emb}}}{6} = 4 \cdot \text{in}$$

assumed eccentricity for C_1 , resultant compression resistance on socket side

$$y_1 := \frac{l_{\text{emb}}}{6} = 4 \cdot \text{in}$$

eccentricity for C_2 , compression resultant on other socket side

The eccentricities (e , y and y_1) are assumed as resultant locations of stress resultants between socket grout and pile. Please look at Figure 2 to see where these eccentricities occur.

$$\phi_F := 0.9$$

LRFD resistance reduction factor for flexure

$$f_y := 60 \text{ ksi}$$

yield strength of reinforcement

$$E_s := 29000 \text{ ksi}$$

modulus of elasticity of steel

$$\phi_T := 1$$

resistance reduction factor for
strut-tie tension member LRFD
5.5.4.2.1

$$f_c := 4 \text{ ksi}$$

concrete strength

$$\beta_1 := \max \left[0.85 - 0.05 \cdot \frac{(f_c - 4 \text{ ksi})}{\text{ksi}}, 0.65 \right] = 0.85$$

neutral axis multiplier for depth
of concrete stress block, LRFD
5.7.2.2

From first sub-model:

The first analysis sub-model is used to represent a subset of the forces between the pile and socket without any friction. The remaining forces are included in a second sub-model. The total condition is a sum of the two separate sub-models.

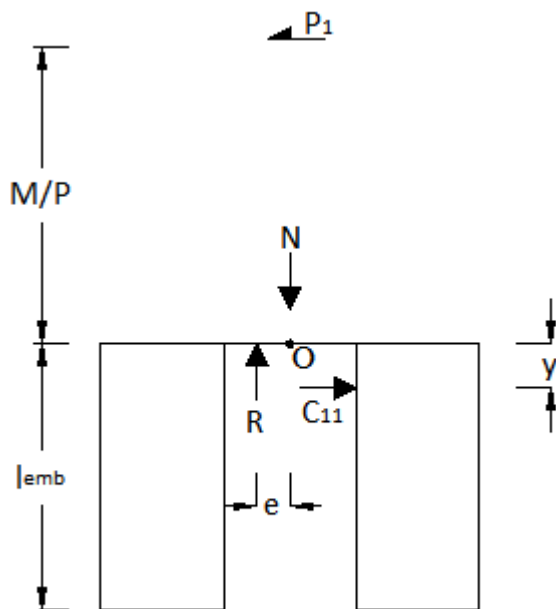

First Sub-Model

Figure 3

Equilibrium in the vertical direction:

$$R := N = 145 \cdot \text{kip}$$

vertical force equilibrium

Equilibrium in the horizontal direction:

$$C_{11}(P_1) := P_1$$

C_{11} is equal to P_1 and here we define C_{11} as a function of P_1 , P_1 is a portion of the total lateral force "P"

$\Sigma M_0 = 0$, Moment equilibrium:

$$P_1 := \text{root} \left[\left[P_1 \cdot \left(\frac{M}{P} \right) + C_{11}(P_1) \cdot y - R \cdot e \right], P_1 \right]$$

root of this equation gives us the value of P_1 equating the total moment to zero with respect to point 0

$$P_1 = 9.766 \cdot \text{kip}$$

$$C_{11}(P_1) = 9.766 \cdot \text{kip}$$

From second sub-model:

The remaining socket-pile forces are resolved using Figure 4.

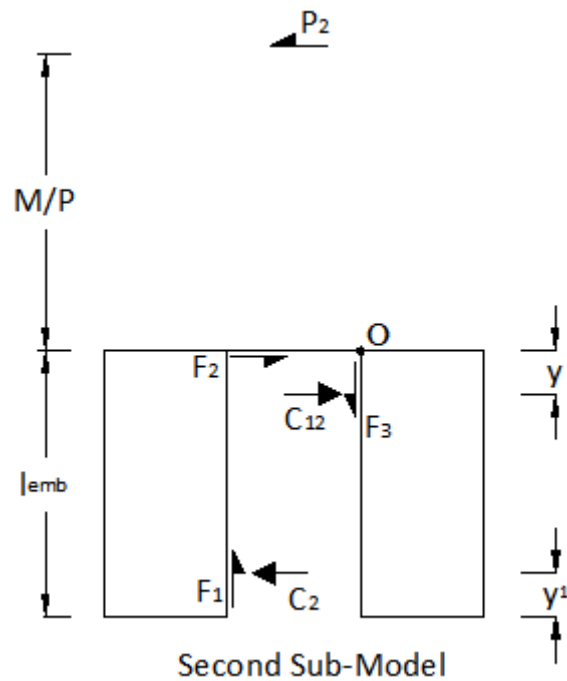

Figure 4

$$P_2 := P - P_1 = 27.234 \cdot \text{kip}$$

P_2 is the remaining lateral load that needs to be resisted by the connection

Equilibrium in the vertical direction:

Assuming α is same for both F_1 and F_3 , where α = coefficient of friction between steel and concrete:

$$\alpha := 0.25$$

$$F_1 = F_3$$

Then considering lateral forces:

C_2 is taken as a function of C_{12}

$$C_2(C_{12}) := C_{12}$$

since $F_1 = C_2 \cdot \alpha$
 $F_3 = C_{12} \cdot \alpha$
 $F_1 = F_3$, then
 $C_{12} = C_2$

where F_1 and F_3 are functions of C_{12}

$$F_1(C_{12}) := \alpha \cdot C_{12}$$

$$F_3(C_{12}) := \alpha \cdot C_{12}$$

Equilibrium in the horizontal direction:

$$F_2 := P_2 = 27.234 \cdot \text{kip}$$

since $C_{12} = C_2$, only F_2 remains to resist remaining lateral load P_2

Considering moment equilibrium about point "O", $\Sigma M_0 = 0$:

$$C_{12} := \text{root} \left[\left[P_2 \cdot \left(\frac{M}{P} \right) + C_{12} \cdot y - F_1(C_{12}) \cdot h - C_2(C_{12}) \cdot (l_{\text{emb}} - y_1) \right], C_{12} \right]$$

$$C_{12} = 58.109 \cdot \text{kip}$$

$$C_1 := C_{11}(P_1) + C_{12} = 67.875 \cdot \text{kip}$$

where C_1 is the total resultant compression at top of the pile

$$C_2 := C_{12} = 58.109 \cdot \text{kip}$$

Summary of design forces:

$$F_2 = 27.234 \cdot \text{kip}$$

$$R = 145 \cdot \text{kip}$$

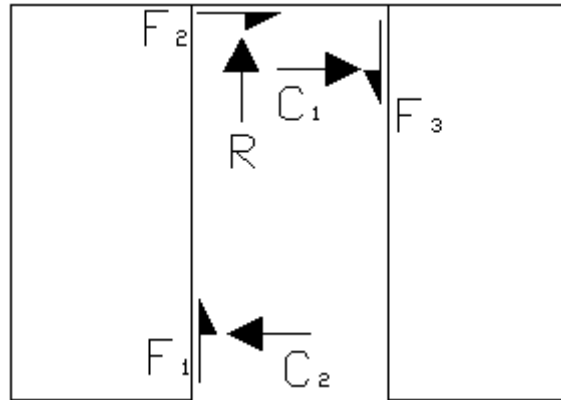

$$C_1 = 67.875 \cdot \text{kip}$$

$$F_3(C_{12}) = 14.527 \cdot \text{kip}$$

$$F_1(C_{12}) = 14.527 \cdot \text{kip}$$

$$C_2 = 58.109 \cdot \text{kip}$$

**Side View
Figure 5**

Reinforcement Calculation:

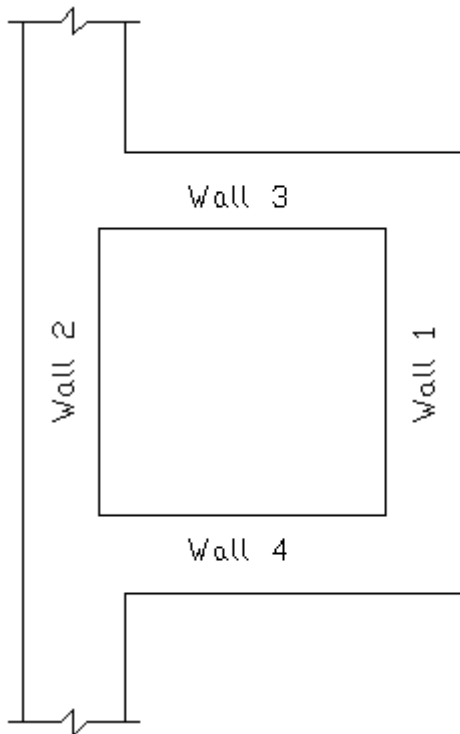

**Plan View of Socket
Figure 6**

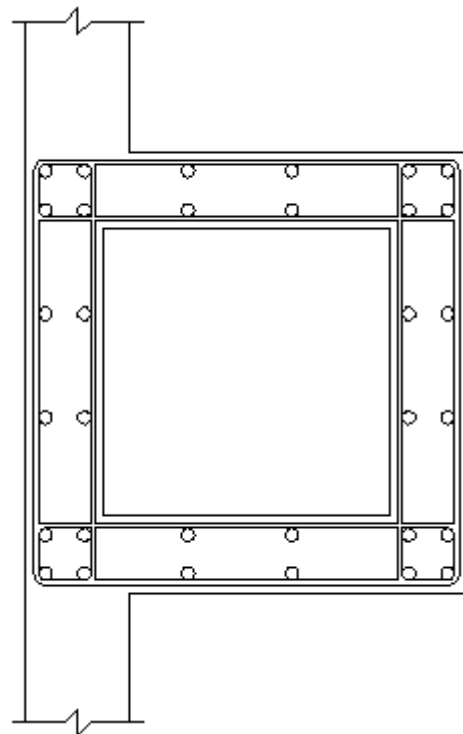

**Plan View of Socket Reinforcing
Figure 7**

Wall 1 and 2 are the transverse walls whereas wall 3 and 4 are parallel walls to applied forces. Wall 2 is part of the abutment wall and wall 1 is the outside of the socket. Symmetric reinforcements from side-side and top-bottom are named as below.

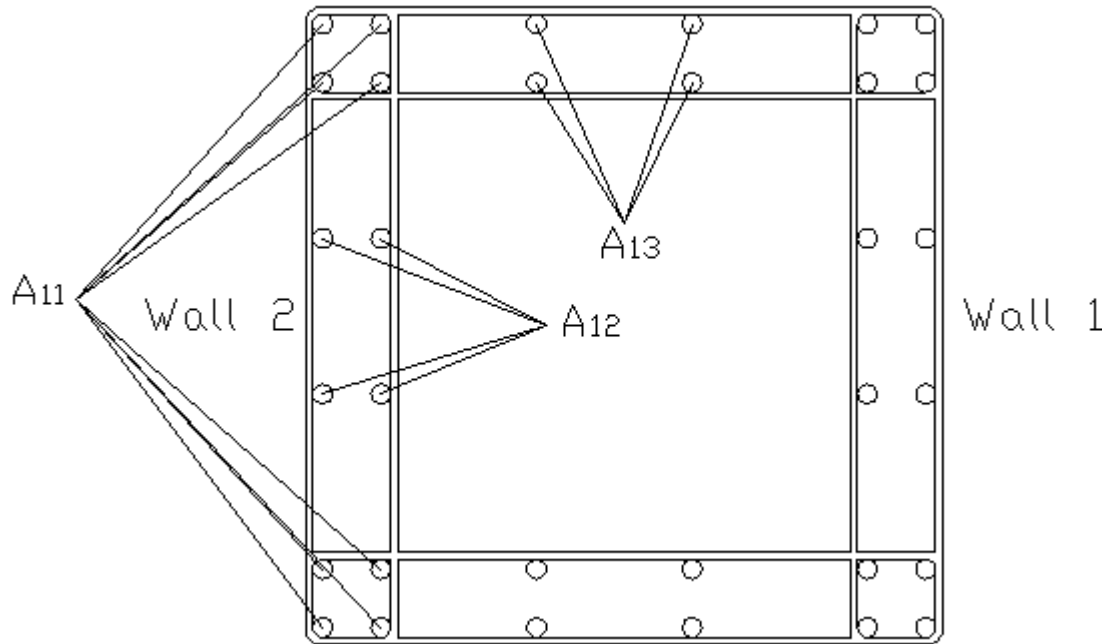

Figure 8

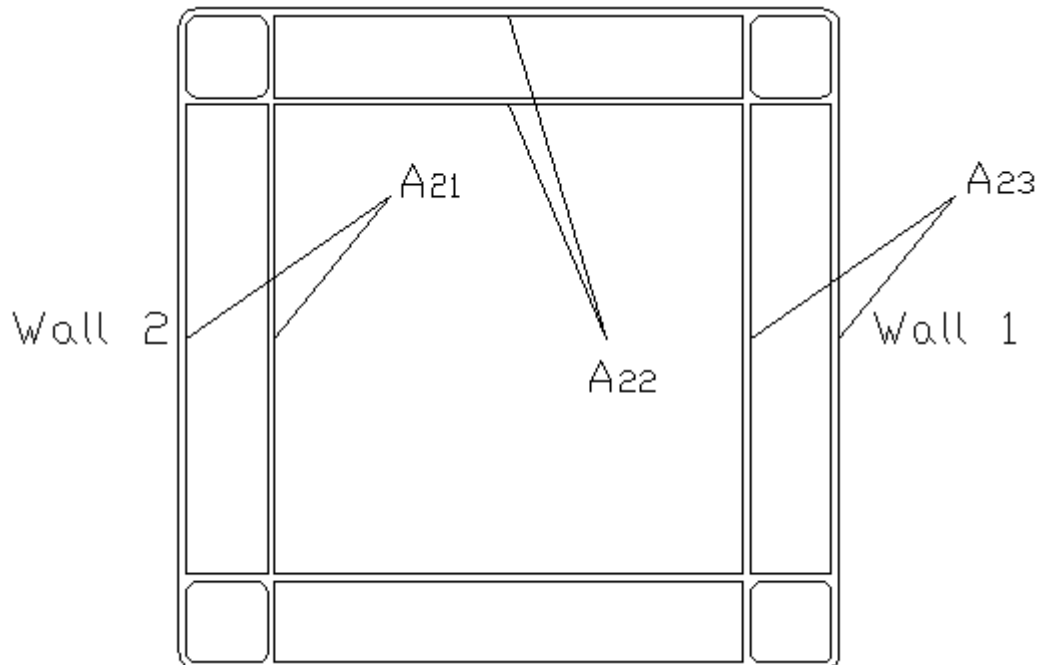

Figure 9

Reinforcement labeled as A_{12} is column reinforcement and it will be coming from that analysis

Epoxy coated steel bars will be used for the socket region. For that reason, concrete cover to main reinforcing will be 1.5" for exterior rebars and 1" for interior rebars. Moreover, cover to ties and stirrups will not be less than 1" (interior rebars are assumed on inside surfaces of socket, where concrete will be placed later to complete the connection).

$$\text{cover}_{\text{int}} := 1 \text{ in}$$

$$\text{cover}_{\text{ext}} := 1.5 \text{ in}$$

A resistance concept is needed in the socket design to resist the forces just found. Truss action is assumed in the "disturbed" socket region as recommended by AASHTO (LRFD 5.6.3.1). Figure 10 shows a cross section through the wall with a suggested truss mechanism.

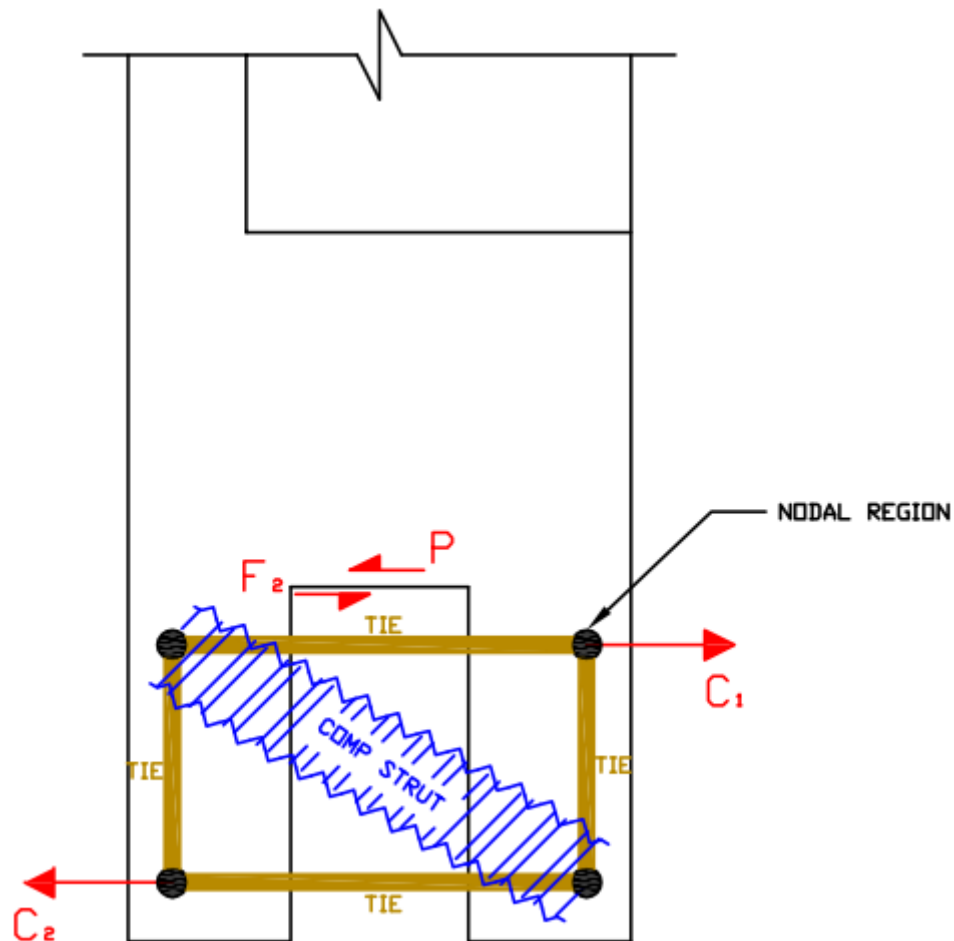

Side View
Figure 10

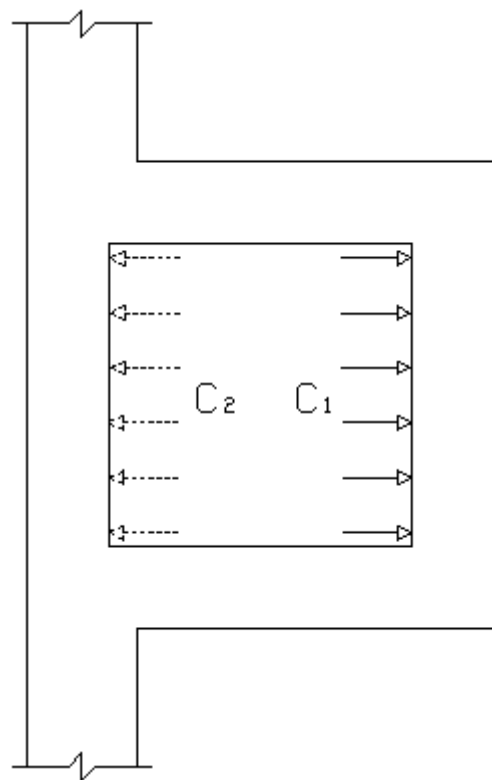

**Plan View
Figure 11**

For parallel walls(3&4) the reinforcement is needed (Figure 10):

Tie at top of socket:

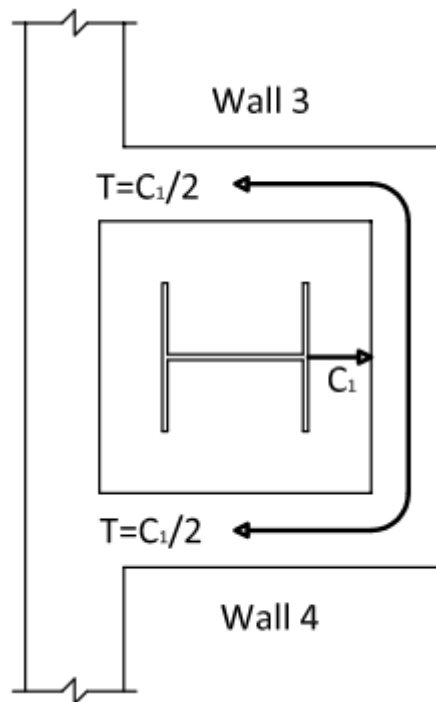

Figure 12

C_1 is applied to wall 1 (Figure 11) and is resisted by tension ties in walls 3&4 as shown in Figure 10.

Try different size and number of reinforcements until $T_{provided} > T_{req}$ and $T = C_1/2$, since one tie is in each of walls 3&4 as in Figure 12.

For region where C_1 is applied (top) (reinforcement A_{22}):

Bars are assumed and capacity is checked.

$$N_{barT1} := 5$$

rebar size

$$n_{barT1} := 2$$

number of rebars

$$T_{1\text{req}} := \frac{C_1}{2} = 33.938 \cdot \text{kip} \quad (\text{see Figure 12})$$

$$T_{1\text{provided}} := \left[n_{\text{barT1}} \cdot \frac{\pi \cdot \left(\frac{N_{\text{barT1}} \text{ in}}{8} \right)^2}{4} \cdot f_y \right] \cdot \phi_T = 36.816 \cdot \text{kip} \quad \text{tension capacity of bars}$$

$$\text{reinforcement_is} := \begin{cases} \text{"enough"} & \text{if } T_{1\text{provided}} > T_{1\text{req}} \\ \text{"not enough"} & \text{otherwise} \end{cases}$$

$$\text{reinforcement_is} = \text{"enough"}$$

Tie at bottom of socket:

For region where C_2 is applied (bottom) (reinforcement A_{22}), the approach is similar to top tie:

$$N_{\text{barT2}} := 5 \quad \text{rebar size}$$

$$n_{\text{barT2}} := 2 \quad \text{number of rebars}$$

$$T_{2\text{req}} := \frac{C_2}{2} = 29.054 \cdot \text{kip}$$

$$T_{2\text{provided}} := \left[n_{\text{barT2}} \cdot \frac{\pi \cdot \left(\frac{N_{\text{barT2}} \text{ in}}{8} \right)^2}{4} \cdot f_y \right] \cdot \phi_T = 36.816 \cdot \text{kip}$$

$$\text{reinforcement_is} := \begin{cases} \text{"enough"} & \text{if } T_{2\text{provided}} > T_{2\text{req}} \\ \text{"not enough"} & \text{otherwise} \end{cases}$$

$$\text{reinforcement_is} = \text{"enough"}$$

For bending of transverse walls 1&2, flexural reinforcing:

$$b_{\text{int}} := 22 \text{ in} \quad \text{inner dimension of the socket}$$

$$h_w := 6 \text{ in} \quad \text{thickness of the socket wall}$$

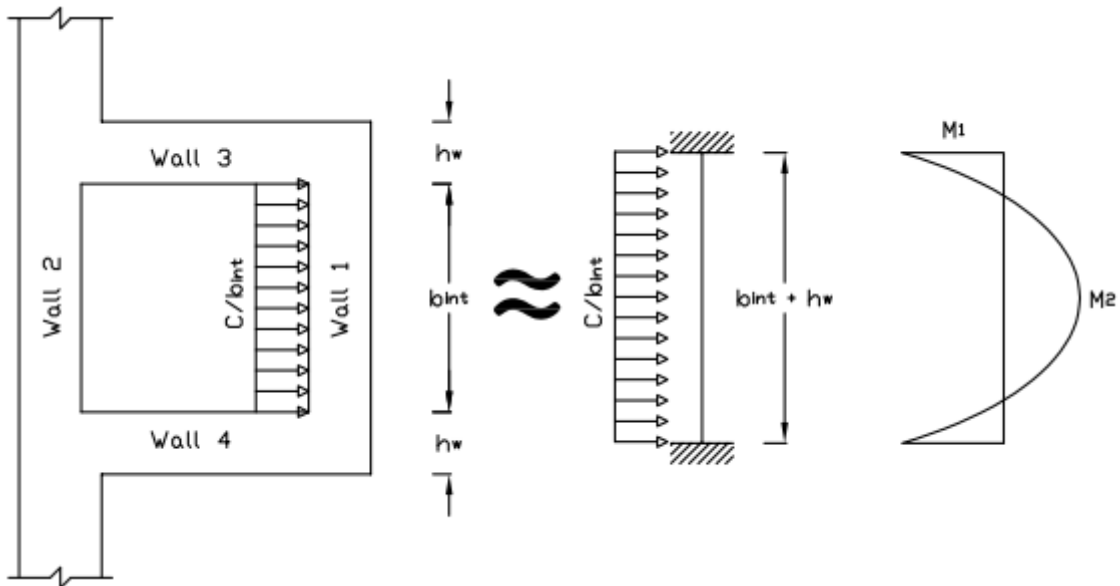

Plan View
Figure 13

$$M_1 = M_2 = (C / b_{int}) \cdot (b_{int} + h_w)^2 / 16$$

As shown in Figures 11&13, the load intensity is calculated from the internal socket width but the moments are conservatively taken for a longer span. The bending moments in the socket wall are assumed to be "partially fix ended" since the walls 3 & 4 apply some bending restraint to walls 1 & 2. The assumed moment diagram is also shown in Figure 13.

1) Flexure - For region where C_1 is applied (top) (reinforcement A_{23} - see Figure 9):

$$w_1 := \frac{C_1}{b_{int}} = 37.023 \cdot \frac{\text{kip}}{\text{ft}}$$

distributed load on inner face of wall due to C_1 force

$$M_d := \frac{w_1 \cdot (b_{int} + h_w)^2}{16} = 12.598 \cdot \text{kip} \cdot \text{ft}$$

conservative estimate of design moment for both negative and positive region with "supports" assumed at middle of walls 3 & 4

Assuming the effective concrete width (vertical) for wall 1 acting as a beam is $l_{emb} / 4$:

Please change the amount of steel until sufficient capacity is achieved, the amount of reinforcement which is entered below is same for both positive and negative reinforcement:

$$N_{\text{barFL1}} := 5$$

rebar size

$$n_{\text{barFL1}} := 3$$

number of rebars

$$A_s := n_{\text{barFL1}} \cdot \frac{\pi \cdot \left(\frac{N_{\text{barFL1}} \cdot \text{in}}{8} \right)^2}{4} = 0.92 \cdot \text{in}^2$$

amount of reinforcement

Assuming compression steel is in compression and has not yielded:

$$\epsilon_s(x) := 0.003 \cdot \left[\frac{x - \text{cover}_{\text{int}} - \left(\frac{N_{\text{barFL1}}}{8} \cdot \text{in} \right) \cdot \frac{1}{2}}{x} \right]$$

strain in compression steel

$$f(x) := 0.85 \cdot f_c \cdot \frac{l_{\text{emb}}}{4} \cdot \beta_1 \cdot x + A_s \cdot (E_s \cdot \epsilon_s(x) - 0.85 f_c) - A_s \cdot f_y$$

axial force equilibrium in beam

$$x := 1 \text{ in}$$

initial guess for neutral axis depth

$$x := \text{root}(f(x), x) = 1.914 \cdot \text{in}$$

neutral axis depth

$$C := 0.85 \cdot f_c \cdot \left(\frac{l_{\text{emb}}}{4} \cdot \beta_1 \cdot x - A_s \right) = 30.059 \cdot \text{kip}$$

compression force in concrete

$$C_s := A_s \cdot E_s \cdot \epsilon_s(x) = 25.164 \cdot \text{kip}$$

force in compression steel
(positive is compression)

$$d := h_w - \text{cover}_{\text{ext}} - \frac{N_{\text{barFL1}}}{8} \cdot \text{in} \cdot \frac{1}{2} = 4.188 \cdot \text{in}$$

effective depth of the section

Check if compression steel is in compression:

$$\text{check}_1 := \begin{cases} \text{"Ok"} & \text{if } x > \left(\text{cover}_{\text{int}} + \frac{N_{\text{barFL1}}}{8} \cdot \text{in} \cdot \frac{1}{2} \right) \\ \text{"tension"} & \text{otherwise} \end{cases}$$

$$\text{check}_1 = \text{"Ok"}$$

Check if compression steel has yielded:

$$\text{check_2} := \begin{cases} \text{"Ok"} & \text{if } |\varepsilon_s(x)| < \frac{f_y}{E_s} \\ \text{"not Ok"} & \text{otherwise} \end{cases}$$

"Ok" if not yielded, if yielded then separate calculations are required

$$\text{check_2} = \text{"Ok"}$$

Moment capacity is:

$$M_{\text{provided}} := \phi_F \cdot \left[C_c \cdot \left(d - \frac{\beta_1 \cdot x}{2} \right) + C_s \cdot \left[d - \text{cover}_{\text{int}} - \left(\frac{N_{\text{barFL1}}}{8} \text{in} \right) \cdot \frac{1}{2} \right] \right] = 13.033 \cdot \text{kip} \cdot \text{ft}$$

Check if the capacity is enough:

$$\text{moment_capacity} := \begin{cases} \text{"is enough"} & \text{if } M_{\text{provided}} \geq M_d \\ \text{"is not enough"} & \text{otherwise} \end{cases}$$

$$\text{moment_capacity} = \text{"is enough"}$$

2) Flexure - For region where C_2 is applied (bottom) (reinforcement A_{21}):

$$w_2 := \frac{C_2}{b_{\text{int}}} = 31.696 \cdot \frac{\text{kip}}{\text{ft}}$$

distributed load on inner face of wall at bottom

$$M_d := \frac{w_2 \cdot (b_{\text{int}} + h_w)^2}{16} = 10.785 \cdot \text{kip} \cdot \text{ft}$$

for both negative and positive moment

Assuming the effective concrete width is $l_{\text{emb}} / 4$:

Please change the amount of steel until enough moment capacity is achieved, the amount of reinforcement which is entered below is same for both positive and negative reinforcement:

$$N_{\text{barFL2}} := 5$$

rebar size

$$n_{\text{barFL2}} := 3$$

number of rebars

$$A_s := n_{\text{barFL2}} \cdot \frac{\pi \cdot \left(\frac{N_{\text{barFL2}}}{8} \text{ in} \right)^2}{4} = 0.92 \cdot \text{in}^2$$

amount of reinforcement

Assuming compression steel is in compression and has not yielded:

$$\epsilon_s(x) := 0.003 \cdot \left[\frac{x - \text{cover}_{\text{int}} - \left(\frac{N_{\text{barFL2}}}{8} \text{ in} \right) \cdot \frac{1}{2}}{x} \right]$$

strain in compression steel

$$f(x) := 0.85 \cdot f_c \cdot \frac{l_{\text{emb}}}{4} \cdot \beta_1 \cdot x + A_s \cdot (E_s \cdot \epsilon_s(x) - 0.85 f_c) - A_s \cdot f_y$$

force equilibrium

$$x := 1 \text{ in}$$

initial guess for neutral axis depth

$$x := \text{root}(f(x), x) = 1.914 \cdot \text{in}$$

neutral axis depth

$$C := 0.85 \cdot f_c \cdot \frac{l_{\text{emb}}}{4} \cdot \beta_1 \cdot x - 0.85 f_c \cdot A_s = 30.059 \cdot \text{kip}$$

compression force in concrete

$$C_s := A_s \cdot E_s \cdot \epsilon_s(x) = 25.164 \cdot \text{kip}$$

force in compression steel
(positive is compression)

$$d := h_w - \text{cover}_{\text{ext}} - \frac{N_{\text{barFL2}}}{8} \text{ in} \cdot \frac{1}{2} = 4.188 \cdot \text{in}$$

effective depth of the section

Check if compression steel is in compression:

$$\text{check}_1 := \begin{cases} \text{"Ok"} & \text{if } x > \left(\text{cover}_{\text{int}} + \frac{N_{\text{barFL2}}}{8} \text{ in} \cdot \frac{1}{2} \right) \\ \text{"tension"} & \text{otherwise} \end{cases}$$

$$\text{check}_1 = \text{"Ok"}$$

Check if compression steel has yielded:

$$\text{check_2} := \begin{cases} \text{"Ok"} & \text{if } \left| \varepsilon_s(x) \right| < \frac{f_y}{E_s} \\ \text{"not Ok"} & \text{otherwise} \end{cases}$$

"Ok" if not yielded, if yielded then separate calculations are required

$$\text{check_2} = \text{"Ok"}$$

Moment capacity is:

$$M_{\text{provided}} := \phi_F \cdot \left[C \cdot \left(d - \frac{\beta_1 \cdot x}{2} \right) + C_s \cdot \left[d - \text{cover}_{\text{int}} - \left(\frac{N_{\text{barFL1}}}{8} \text{ in} \right) \cdot \frac{1}{2} \right] \right] = 13.033 \cdot \text{kip} \cdot \text{ft}$$

Check if the capacity is enough:

$$\text{moment_capacity} := \begin{cases} \text{"is enough"} & \text{if } M_{\text{provided}} \geq M_d \\ \text{"is not enough"} & \text{otherwise} \end{cases}$$

$$\text{moment_capacity} = \text{"is enough"}$$

Punching Failure Check for Wall 1, ACI 318-08 Section 11.11:

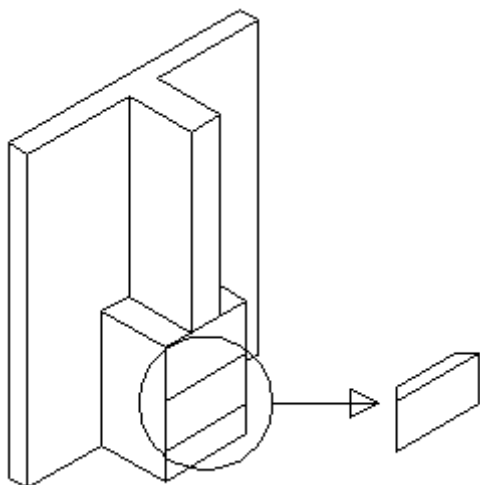

Figure 14
Isometric View of Punching Shear Region

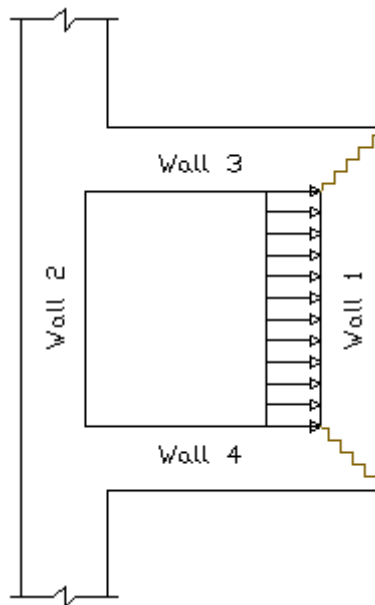

Figure 15
Punching Failure

$$\phi_{punc} := 0.75$$

strength reduction factor for shear from ACI

$$b_o := \begin{cases} 2 \cdot \left(\frac{l_{emb}}{3} + d \right) + 2(b_{int} + d) & \text{if } l_{emb} \leq (4ft - d) \\ 2 \cdot \left(\frac{l_{emb}}{3} + d \right) + (b_{int} + d) & \text{otherwise} \end{cases}$$

critical perimeter, taken $d/2$ away from concentrated load area, assuming that crack occurs with a strip depth of $l_{emb}/3$

$$b_o = 76.75 \cdot \text{in}$$

Above equation for b_o indicates that if the embedment of the pile is same or pretty close to socket length (4ft), the critical perimeter reduces.

$$\text{constant} := \min \left[\left[2 + \frac{4}{\frac{b_{int}}{\left(\frac{l_{emb}}{3} \right)}} \right], \left[2 + \frac{20}{\frac{b_o}{d}} \right], 2 \right] = 2$$

minimum of those constants will be used per ACI code

$$V_{c_punc} := \text{constant} \cdot \left[\left(\sqrt{\frac{f_c}{\text{psi}}} \right) \cdot b_o \cdot d \right] = 40.653 \cdot \text{kip}$$

Strength coming from rebars:

$$V_{s_punc} := \left[2 \cdot n_{\text{barT1}} \cdot \pi \cdot \left(\frac{N_{\text{barT1}}}{8} \cdot \text{in} \cdot \frac{1}{2} \right)^2 \right] \cdot f_y = 73.631 \cdot \text{kip}$$

the reinforcement crossing the shear crack, A_{22} , was calculated previously to resist C_1

$$V_{n1} := V_{c_punc} + V_{s_punc} = 114.284 \cdot \text{kip} \quad \text{ACI Eq. (11-2)}$$

$$V_{n2} := 6 \cdot \left(\sqrt{\frac{f_c}{\text{psi}}} \right) \cdot b_o \cdot d = 121.959 \cdot \text{kip} \quad \text{ACI 11.11.3.2}$$

$$V_n := \min(V_{n1}, V_{n2}) = 114.284 \cdot \text{kip}$$

$$C_1 = 67.875 \cdot \text{kip}$$

$$\text{punching_strength} := \begin{cases} \text{"is enough"} & \text{if } \phi_{\text{punc}} \cdot V_n \geq C_1 \\ \text{"is not enough"} & \text{otherwise} \end{cases}$$

$$\text{punching_strength} = \text{"is enough"}$$

Shrinkage and Temperature Reinforcement in Socket Walls, LRFD 5.10.8 (reinforcement A_{13} - see Figure 8):

The area of S&T reinforcement per foot, on each face and in each direction shall not be less than:

$$A_{ST} := \left[\frac{1.3 \cdot \frac{(b_{\text{int}} + 2h_w)^2 - b_{\text{int}}^2}{\text{in}^2}}{\frac{4(b_{\text{int}} + 2h_w) + 4b_{\text{int}}}{\text{in}} \cdot \frac{f_y}{\text{ksi}}} \right] \frac{\text{in}^2}{\text{ft}} = 0.065 \cdot \frac{\text{in}^2}{\text{ft}}$$

This amount of reinforcement is 1.3 times area of gross concrete divided by perimeter exposed to air times yield strength of steel.

Furthermore, A_s should satisfy following conditions:

$$A_{ST} := \begin{cases} 0.11 \frac{\text{in}^2}{\text{ft}} & \text{if } A_{ST} \leq 0.11 \frac{\text{in}^2}{\text{ft}} \\ 0.6 \frac{\text{in}^2}{\text{ft}} & \text{if } A_{ST} \geq 0.6 \frac{\text{in}^2}{\text{ft}} \\ A_{ST} & \text{otherwise} \end{cases}$$

defines the limits for reinforcement

$$A_{ST} := b_{\text{int}} \cdot A_{ST} = 0.202 \cdot \text{in}^2$$

total S&T reinforcement required for the cross section

Now please enter reinforcement amount below to get the required S&T reinforcement:

$$N_{\text{barTS}} := 3$$

rebar size

$$A_{13} := 4 \cdot \pi \cdot \left(\frac{N_{\text{barTS}}}{8} \cdot \text{in} \frac{1}{2} \right)^2 = 0.442 \cdot \text{in}^2$$

number of reinforcements are 4 as can be seen from the drawings, but it can be increased checking the spacing limitations

$$\text{check} := \begin{cases} \text{"ok"} & \text{if } A_{13} \geq A_{ST} \\ \text{"add reinforcement"} & \text{otherwise} \end{cases}$$

$$\text{check} = \text{"ok"}$$

Maximum spacing can not exceed 3 times the wall thickness or 12in:

$$s_{\text{max1}} := \min(3 \cdot h_w, 12\text{in}) = 12 \cdot \text{in}$$

Longitudinal vertical reinforcement at the corners of walls (reinforcement A_{11}):

At the corner nodes the tension tie forces (C_1 and C_2) are balanced by the horizontal component of the diagonal. The vertical component of the diagonal needs to be resisted by vertical (longitudinal) reinforcing at the wall corners. After calculating the force (F) needed for this balance, we will determine the required area of reinforcement.

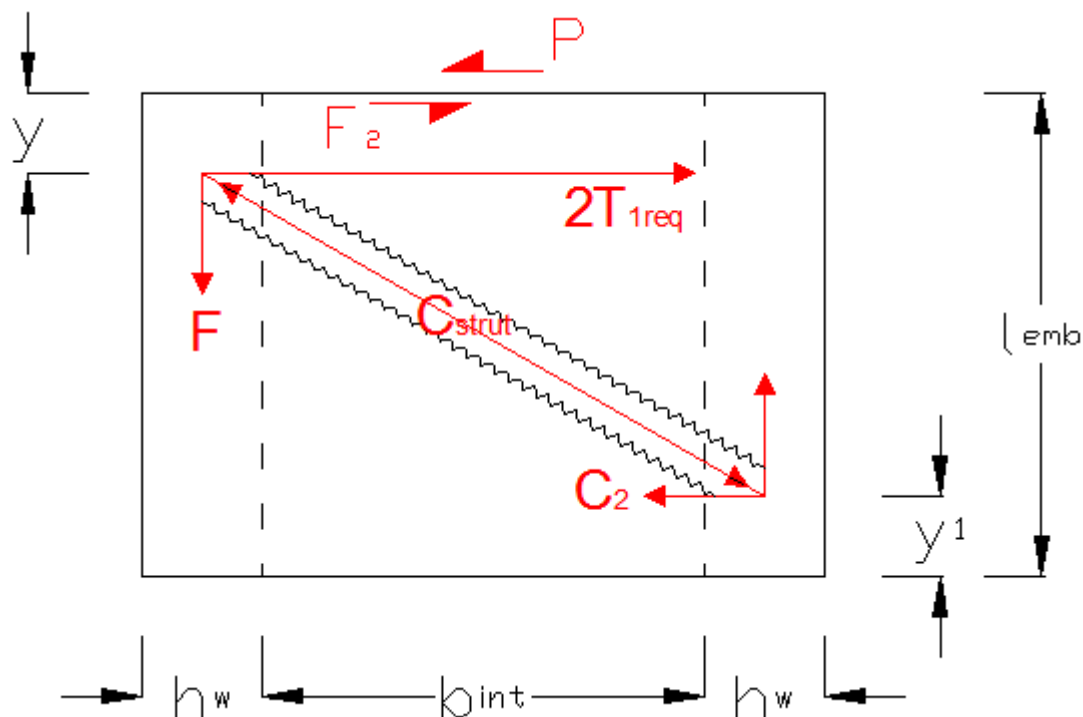

Figure 16
Ties & Struts in Socket
Elevation View

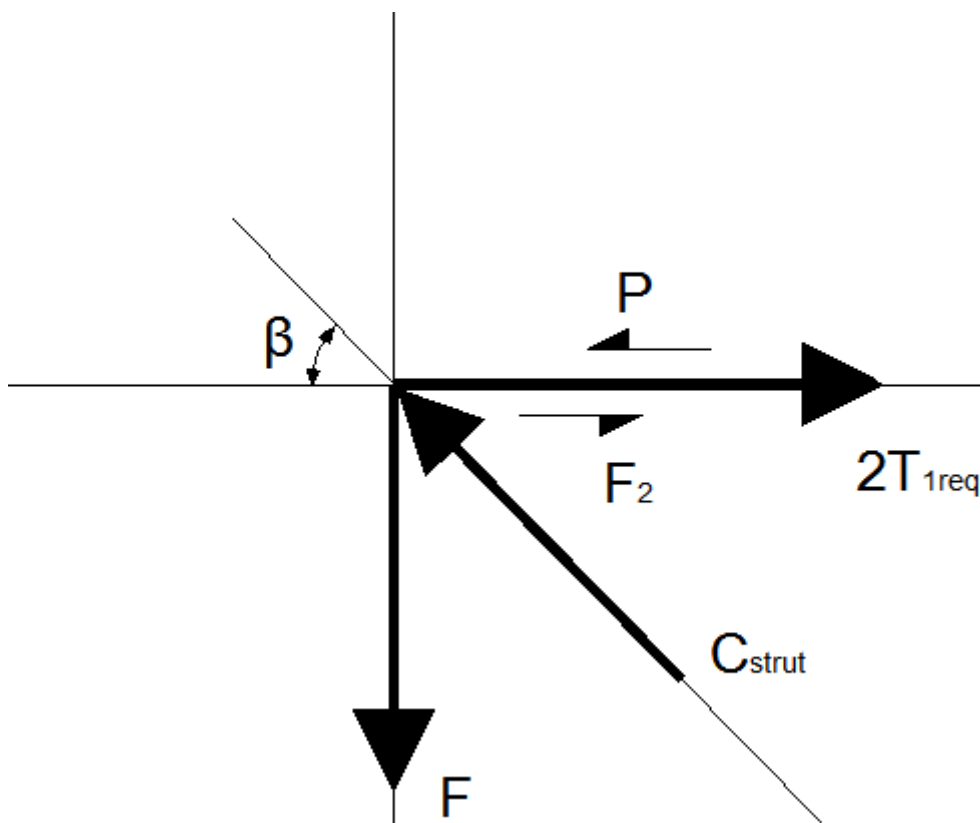

Figure 17

$$\beta := \operatorname{atan}\left(\frac{l_{\text{emb}} - y - y_1}{b_{\text{int}} + h_w}\right) = 29.745 \cdot \text{deg}$$

the strut angle depends on socket size and pile embedment length, strut-tie joint is assumed at middle of wall thickness

$$C_{\text{strut}} \cdot \cos(\beta) = 2 \cdot T_{1\text{req}} - (P - F_2)$$

from horizontal equilibrium at top (see Figures 16 & 17) with the lateral load P and the top friction F_2

$$C_{\text{strut}} := \frac{2T_{1\text{req}} - (P - F_2)}{\cos(\beta)} = 66.927 \cdot \text{kip}$$

$$F_{\text{req}} := C_{\text{strut}} \cdot \sin(\beta) = 33.205 \cdot \text{kip}$$

Try different size of reinforcements until $F_{\text{provided}} > F_{\text{req}}$.

$$N_{\text{barF}} := 3$$

rebar size

We will have 4 rebars at each corner, therefore, for one side we have 8 bars!

$$F_{\text{provided}} := 8 \cdot \left[\frac{\pi \cdot \left(\frac{N_{\text{barF}} \cdot \text{in}}{8} \right)^2}{4} \right] \cdot f_y \cdot \phi_T = 53.014 \cdot \text{kip}$$

$$\text{reinforcement_is} := \begin{cases} \text{"enough"} & \text{if } F_{\text{provided}} > F_{\text{req}} \\ \text{"not enough"} & \text{otherwise} \end{cases}$$

$$\text{reinforcement_is} = \text{"enough"}$$

Check also whether or not concrete is safe in strut, LRFD 5.6.3:

$$\phi_c := 0.7$$

for compression in strut, LRFD 5.5.4.2

$$\epsilon_{T1} := \frac{T_{1\text{req}}}{n_{\text{barT1}} \cdot \left[\frac{\pi \cdot \left(\frac{N_{\text{barT1}} \cdot \text{in}}{8} \right)^2}{4} \right] \cdot E_s} = 1.907 \times 10^{-3}$$

strain in tension ties

$$\alpha_s := \beta$$

the smallest angle between the compressive strut and adjoining tension ties (deg)

$$\epsilon_1 := \epsilon_{T1} + (\epsilon_{T1} + 0.002) \cdot \cot(\alpha_s)^2 = 0.014$$

$$f_{cu} := \min \left(\frac{f_c}{0.8 + 170 \cdot \epsilon_1}, 0.85 f_c \right) = 1.266 \cdot \text{ksi}$$

$$C_{\text{provided}} := \phi_c \cdot (2 \cdot f_{\text{cu}} \cdot h_w^2) = 63.829 \cdot \text{kip}$$

provided concrete strength in strut
assuming strut size is $h_w \times h_w$

concrete_in_strut_is :=

"safe"	if $C_{\text{provided}} > C_{\text{strut}}$
"not safe"	otherwise

concrete_in_strut_is = "not safe"

It seems that concrete in compression does not have adequate strength to resist strut force therefore, the thickness of the side cheeks (or the thickness of the complete socket region) can be increased by 1/2" or more.

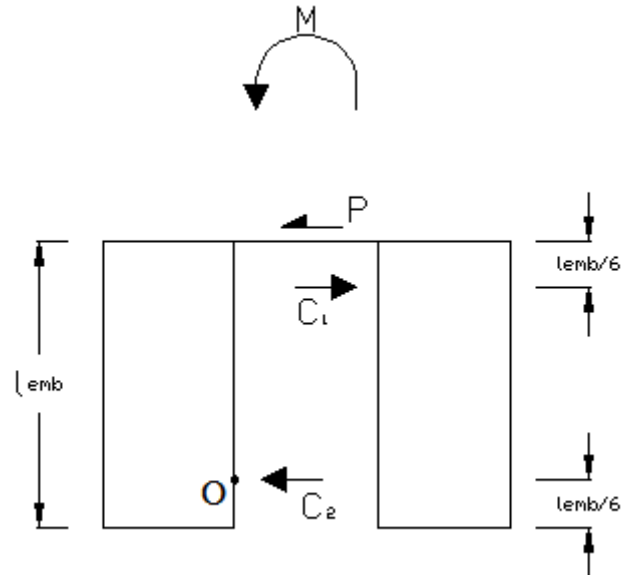
Ignoring Friction Forces:

$$\Sigma M_0 = 0$$

$$C_1 := \frac{M + P \cdot \left(\frac{5}{6} l_{emb}\right)}{\left(\frac{2}{3} l_{emb}\right)} = 140 \cdot \text{kip}$$

Equilibrium in the horizontal direction:

$$C_2 := C_1 - P = 103 \cdot \text{kip}$$

Reinforcement Calculation:

For parallel walls(3&4) the reinforcement is needed (Figure 10):

Tie at top of socket:

Try different size and number of reinforcements until $T_{provided} > T_{req}$ and $T = C_1/2$ since one tie is in each of walls 3&4 as in Figure 12.

For region where C_1 is applied (top) (reinforcement A_{22}):

Bars are assumed and capacity is checked.

$$N_{barT1} := 5$$

rebar size

$$n_{barT1} := 4$$

number of rebars

$$T_{Ireq} := \frac{C_1}{2} = 70 \cdot \text{kip}$$

(see Figure 12)

$$T_{Iprovided} := \left[n_{barT1} \cdot \frac{\pi \cdot \left(\frac{N_{barT1} \cdot \text{in}}{8} \right)^2}{4} \cdot f_y \right] \cdot \phi_T = 73.631 \cdot \text{kip}$$

tension capacity of bars

$$\text{reinforcement_is} := \begin{cases} \text{"enough"} & \text{if } T_{Iprovided} > T_{Ireq} \\ \text{"not enough"} & \text{otherwise} \end{cases}$$

$$\text{reinforcement_is} = \text{"enough"}$$

Tie at bottom of socket:

For region where C_2 is applied (bottom) (reinforcement A_{22}), the approach is similar to top tie:

$$N_{barT2} := 5$$

rebar size

$$n_{barT2} := 3$$

number of rebars

$$T_{2req} := \frac{C_2}{2} = 51.5 \cdot \text{kip}$$

$$T_{2provided} := \left[n_{barT2} \cdot \frac{\pi \cdot \left(\frac{N_{barT2} \cdot \text{in}}{8} \right)^2}{4} \cdot f_y \right] \cdot \phi_T = 55.223 \cdot \text{kip}$$

$$\text{reinforcement_is} := \begin{cases} \text{"enough"} & \text{if } T_{2\text{provided}} > T_{2\text{req}} \\ \text{"not enough"} & \text{otherwise} \end{cases}$$

$$\text{reinforcement_is} = \text{"enough"}$$

For bending of transverse walls 1&2, flexural reinforcing:

1) Flexure - For region where C_1 is applied (top) (reinforcement A_{23} - see Figure 9):

$$w_1 := \frac{C_1}{b_{\text{int}}} = 76.364 \cdot \frac{\text{kip}}{\text{ft}}$$

$$M_d := \frac{w_1 \cdot (b_{\text{int}} + h_w)^2}{16} = 25.985 \cdot \text{kip} \cdot \text{ft}$$

Please change the amount of steel until sufficient capacity is achieved, the amount of reinforcement which is entered below is same for both positive and negative reinforcement:

$$N_{\text{barFL1}} := 7$$

rebar size

$$n_{\text{barFL1}} := 4$$

number of rebars

$$A_s := n_{\text{barFL1}} \cdot \frac{\pi \cdot \left(\frac{N_{\text{barFL1}}}{8} \text{ in} \right)^2}{4} = 2.405 \cdot \text{in}^2$$

amount of reinforcement

Assuming compression steel is in compression and has not yielded:

$$\epsilon_s(x) := 0.003 \cdot \left[\frac{\left[x - \text{cover}_{\text{int}} - \left(\frac{N_{\text{barFL1}}}{8} \text{ in} \right) \cdot \frac{1}{2} \right]}{x} \right]$$

strain in compression steel

$$f(x) := 0.85 \cdot f_c \cdot \frac{l_{\text{emb}}}{4} \cdot \beta_1 \cdot x + A_s \cdot (E_s \cdot \epsilon_s(x) - 0.85 f_c) - A_s \cdot f_y$$

axial force equilibrium in beam

$$x := 1 \text{ in}$$

initial guess for neutral axis depth

$$x := \text{root}(f(x), x) = 2.838 \cdot \text{in}$$

neutral axis depth

$$C := 0.85 \cdot f_c \cdot \frac{l_{emb}}{4} \cdot \beta_1 \cdot x - 0.85 f_c \cdot A_s = 41.039 \cdot \text{kip}$$

compression force in concrete

$$C_s := A_s \cdot E_s \cdot \epsilon_s(x) = 103.278 \cdot \text{kip}$$

force in compression steel
(positive is compression)

$$d := h_w - \text{cover}_{ext} - \frac{N_{barFL1}}{8} \text{in} \cdot \frac{1}{2} = 4.063 \cdot \text{in}$$

effective depth of the section

Check if compression steel is in compression:

$$\text{check_1} := \begin{cases} \text{"Ok"} & \text{if } x > \left(\text{cover}_{int} + \frac{N_{barFL1}}{8} \text{in} \cdot \frac{1}{2} \right) \\ \text{"tension"} & \text{otherwise} \end{cases}$$

$$\text{check_1} = \text{"Ok"}$$

Check if compression steel has yielded:

$$\text{check_2} := \begin{cases} \text{"Ok"} & \text{if } |\epsilon_s(x)| < \frac{f_y}{E_s} \\ \text{"not Ok"} & \text{otherwise} \end{cases}$$

"Ok" if not yielded, if yielded then
separate calculations are required

$$\text{check_2} = \text{"Ok"}$$

Moment capacity is:

$$M_{provided} := \phi_F \cdot \left[C \cdot \left(d - \frac{\beta_1 \cdot x}{2} \right) + C_s \cdot \left[d - \text{cover}_{int} - \left(\frac{N_{barFL1}}{8} \text{in} \right) \cdot \frac{1}{2} \right] \right] = 29.124 \cdot \text{kip} \cdot \text{ft}$$

Check if the capacity is enough:

$$\text{moment_capacity} := \begin{cases} \text{"is enough"} & \text{if } M_{provided} \geq M_d \\ \text{"is not enough"} & \text{otherwise} \end{cases}$$

$$\text{moment_capacity} = \text{"is enough"}$$

2) Flexure - For region where C_2 is applied (bottom) (reinforcement A_{21}):

$$w_2 := \frac{C_2}{b_{\text{int}}} = 56.182 \cdot \frac{\text{kip}}{\text{ft}}$$

$$M_d := \frac{w_2 \cdot (b_{\text{int}} + h_w)^2}{16} = 19.117 \cdot \text{kip} \cdot \text{ft}$$

Please change the amount of steel until enough moment capacity is achieved, the amount of reinforcement which is entered below is same for both positive and negative reinforcement:

$$N_{\text{barFL2}} := 6$$

rebar size

$$n_{\text{barFL2}} := 4$$

number of rebars

$$A_s := n_{\text{barFL2}} \cdot \frac{\pi \cdot \left(\frac{N_{\text{barFL2}}}{8} \text{ in} \right)^2}{4} = 1.767 \cdot \text{in}^2$$

amount of reinforcement

Assuming compression steel is in compression and has not yielded:

$$\epsilon_s(x) := 0.003 \cdot \left[\frac{\left[x - \text{cover}_{\text{int}} - \left(\frac{N_{\text{barFL2}}}{8} \text{ in} \right) \cdot \frac{1}{2} \right]}{x} \right]$$

strain in compression steel

$$f(x) := 0.85 \cdot f_c \cdot \frac{l_{\text{emb}}}{4} \cdot \beta_1 \cdot x + A_s \cdot (E_s \cdot \epsilon_s(x) - 0.85 f_c) - A_s \cdot f_y$$

force equilibrium

$$x := 1 \text{ in}$$

initial guess for neutral axis depth

$$x := \text{root}(f(x), x) = 2.49 \cdot \text{in}$$

neutral axis depth

$$C := 0.85 \cdot f_c \cdot \frac{l_{\text{emb}}}{4} \cdot \beta_1 \cdot x - 0.85 f_c \cdot A_s = 37.174 \cdot \text{kip}$$

compression force in concrete

$$C_s := A_s \cdot E_s \cdot \epsilon_s(x) = 68.855 \cdot \text{kip}$$

force in compression steel
(positive is compression)

$$d := h_w - \text{cover}_{\text{ext}} - \frac{N_{\text{barFL2}}}{8} \cdot \text{in} \cdot \frac{1}{2} = 4.125 \cdot \text{in}$$

effective depth of the section

Check if compression steel is in compression:

$$\text{check_1} := \begin{cases} \text{"Ok"} & \text{if } x > \left(\text{cover}_{\text{int}} + \frac{N_{\text{barFL2}}}{8} \cdot \text{in} \cdot \frac{1}{2} \right) \\ \text{"tension"} & \text{otherwise} \end{cases}$$

$$\text{check_1} = \text{"Ok"}$$

Check if compression steel has yielded:

$$\text{check_2} := \begin{cases} \text{"Ok"} & \text{if } |\epsilon_s(x)| < \frac{f_y}{E_s} \\ \text{"not Ok"} & \text{otherwise} \end{cases}$$

"Ok" if not yielded, if yielded then
separate calculations are required

$$\text{check_2} = \text{"Ok"}$$

Moment capacity is:

$$M_{\text{provided}} := \phi_F \cdot \left[C \cdot \left(d - \frac{\beta_1 \cdot x}{2} \right) + C_s \cdot \left[d - \text{cover}_{\text{int}} - \left(\frac{N_{\text{barFL1}}}{8} \cdot \text{in} \right) \cdot \frac{1}{2} \right] \right] = 22.428 \cdot \text{kip} \cdot \text{ft}$$

Check if the capacity is enough:

$$\text{moment_capacity} := \begin{cases} \text{"is enough"} & \text{if } M_{\text{provided}} \geq M_d \\ \text{"is not enough"} & \text{otherwise} \end{cases}$$

$$\text{moment_capacity} = \text{"is enough"}$$

Punching Failure Check for Wall 1, ACI 318-08 Section 11.11:

$$b_o := \begin{cases} 2 \cdot \left(\frac{l_{emb}}{3} + d \right) + 2(b_{int} + d) & \text{if } l_{emb} \leq (4ft - d) \\ 2 \cdot \left(\frac{l_{emb}}{3} + d \right) + (b_{int} + d) & \text{otherwise} \end{cases}$$

critical perimeter, taken $d/2$ away from concentrated load area, assuming that crack occurs with a strip depth of $l_{emb}/3$

$$b_o = 76.5 \cdot \text{in}$$

$$\text{constant} := \min \left[\left[2 + \frac{4}{\frac{b_{int}}{\left(\frac{l_{emb}}{3} \right)}} \right], \left[2 + \frac{20}{\frac{b_o}{d}} \right], 2 \right] = 2$$

minimum of those constants will be used per ACI code

$$V_{c_punc} := \text{constant} \cdot \left[\left(\sqrt{\frac{f_c}{\text{psi}}} \right) \cdot \text{psi} \right] \cdot b_o \cdot d = 39.916 \cdot \text{kip}$$

Strength coming from rebars:

$$V_{s_punc} := \left[2 \cdot n_{\text{barT1}} \cdot \pi \cdot \left(\frac{N_{\text{barT1}}}{8} \cdot \text{in} \cdot \frac{1}{2} \right)^2 \right] \cdot f_y = 147.262 \cdot \text{kip}$$

the reinforcement crossing the shear crack, A_{22} , was calculated previously to resist C_1

$$V_{n1} := V_{c_punc} + V_{s_punc} = 187.178 \cdot \text{kip}$$

ACI Eq. (11-2)

$$V_{n2} := 6 \cdot \left(\sqrt{\frac{f_c}{\text{psi}}} \right) \cdot \text{psi} \cdot b_o \cdot d = 119.748 \cdot \text{kip}$$

ACI 11.11.3.2

$$V_n := \min(V_{n1}, V_{n2}) = 119.748 \cdot \text{kip}$$

$$C_1 = 140 \cdot \text{kip}$$

$$\text{punching_strength} := \begin{cases} \text{"is enough"} & \text{if } \phi_{\text{punc}} \cdot V_n \geq C_1 \\ \text{"is not enough"} & \text{otherwise} \end{cases}$$

$$\text{punching_strength} = \text{"is not enough"}$$

Shrinkage and Temperature Reinforcement in Socket Walls, LRFD 5.10.8 (reinforcement A_{13} - see Figure 8):

The area of S&T reinforcement per foot, on each face and in each direction shall not be less than:

$$A_{ST} := \left[\frac{1.3 \cdot \frac{(b_{int} + 2h_w)^2 - b_{int}^2}{in^2}}{\frac{4(b_{int} + 2h_w) + 4b_{int}}{in} \cdot \frac{f_y}{ksi}} \right] \frac{in^2}{ft} = 0.065 \cdot \frac{in^2}{ft}$$

This amount of reinforcement is 1.3 times area of gross concrete divided by perimeter exposed to air times yield strength of steel.

Furthermore, A_s should satisfy following conditions:

$$A_{ST} := \begin{cases} 0.11 \frac{in^2}{ft} & \text{if } A_{ST} \leq 0.11 \frac{in^2}{ft} \\ 0.6 \frac{in^2}{ft} & \text{if } A_{ST} \geq 0.6 \frac{in^2}{ft} \\ A_{ST} & \text{otherwise} \end{cases} \quad \text{defines the limits for reinforcement}$$

$$A_{ST} := b_{int} \cdot A_{ST} = 0.202 \cdot in^2 \quad \text{total S\&T reinforcement required for the cross section}$$

Now please enter reinforcement amount below to get the required S&T reinforcement:

$$N_{barTS} := 3 \quad \text{rebar size}$$

$$A_{13} := 4 \cdot \pi \cdot \left(\frac{N_{barTS}}{8} \cdot in \frac{1}{2} \right)^2 = 0.442 \cdot in^2 \quad \text{number of reinforcements are 4 as can be seen from the drawings, but it can be increased checking the spacing limitations}$$

$$\text{check} := \begin{cases} \text{"ok"} & \text{if } A_{13} \geq A_{ST} \\ \text{"add reinforcement"} & \text{otherwise} \end{cases}$$

$$\text{check} = \text{"ok"}$$

Maximum spacing can not exceed 3 times the wall thickness or 12in:

$$s_{max1} := \min(3 \cdot h_w, 12in) = 12 \cdot in$$

Longitudinal reinforcement at the corners of walls (reinforcement A_{11}):

Tension forces in the top and bottom ties (equal to C_1 and C_2) are balanced with force in vertical reinforcement and a diagonal compression strut that has been formed in concrete. After calculating the force (F) needed for this balance, we will determine the required area of reinforcement.

$$\beta := \operatorname{atan}\left(\frac{l_{\text{emb}} - y - y_1}{b_{\text{int}} + h_w}\right) = 29.745 \cdot \text{deg}$$

the strut angle depends on socket size and pile embedment length, strut-tie joint is assumed at middle of wall thickness

$$C_{\text{strut}} \cdot \cos(\beta) = 2 \cdot T_{1\text{req}} - (P - F_2)$$

from horizontal equilibrium at top (see Figures 16 & 17) with the lateral load P and the top friction F_2

$$C_{\text{strut}} := \frac{2T_{1\text{req}} - (P - F_2)}{\cos(\beta)} = 149.997 \cdot \text{kip}$$

$$F_{\text{req}} := C_{\text{strut}} \cdot \sin(\beta) = 74.419 \cdot \text{kip}$$

Try different size of reinforcements until $F_{\text{provided}} > F_{\text{req}}$.

$$N_{\text{barF}} := 4$$

rebar size

We will have 4 rebars at each corner, therefore, for one side we have 8 bars!

$$F_{\text{provided}} := 8 \cdot \left[\frac{\pi \cdot \left(\frac{N_{\text{barF}}}{8} \text{in} \right)^2}{4} \right] \cdot f_y \cdot \phi_T = 94.248 \cdot \text{kip}$$

$$\text{reinforcement_is} := \begin{cases} \text{"enough"} & \text{if } F_{\text{provided}} > F_{\text{req}} \\ \text{"not enough"} & \text{otherwise} \end{cases}$$

$$\text{reinforcement_is} = \text{"enough"}$$

Check also whether or not concrete is safe in strut, LRFD 5.6.3:

$$\varepsilon_{T1} := \frac{T_{1req}}{n_{barT1} \cdot \left[\frac{\pi \cdot \left(\frac{N_{barT1} \text{ in}}{8} \right)^2}{4} \right] \cdot E_s} = 1.967 \times 10^{-3}$$

strain in tension ties

$$\alpha_s := \beta$$

the smallest angle between the compressive strut and adjoining tension ties (deg)

$$\varepsilon_1 := \varepsilon_{T1} + (\varepsilon_{T1} + 0.002) \cdot \cot(\alpha_s)^2 = 0.014$$

$$f_{cu} := \min\left(\frac{f_c}{0.8 + 170 \cdot \varepsilon_1}, 0.85f_c\right) = 1.25 \cdot \text{ksi}$$

$$C_{provided} := \phi_c \cdot (2 \cdot f_{cu} \cdot h_w^2) = 63.007 \cdot \text{kip}$$

provided concrete strength in strut assuming strut size is $h_w \times h_w$

$$\text{concrete_in_strut_is} := \begin{cases} \text{"safe"} & \text{if } C_{provided} > C_{strut} \\ \text{"not safe"} & \text{otherwise} \end{cases}$$

$$\text{concrete_in_strut_is} = \text{"not safe"}$$

Both punching shear strength and strength of strut are not enough, therefore:

To increase the strut strength and punching strength, thickness of the socket wall and/or concrete strength can be increased.

Increasing the thickness to 9.5" is enough for both strengths!

New Design Examples Abutment Design Sheet

Users Guide:

- What does program do?

This design sheet is intended to show how to determine the amount and the location of the reinforcements other than socket region reinforcement.

- What input is required?

Shape of the abutment module:	H	: Height of the module
	L	: Length of the module
	t	: Thickness of the wall
Material properties:	f_c	: Strength of the concrete
	f_y	: Yield strength of steel
	E_s	: Modulus of elasticity of steel
Loads:	M	: Factored design moment acting above per pile
	N	: Factored axial design force acting above per pile
	V	: Factored design shear force acting above per pile
	p_{LS}	: Unfactored maximum pressure at the bottom of abutment module due to live load surcharge
	p_{EH}	: Unfactored maximum pressure at the bottom of abutment module due to earth pressure
Load factors:	Φ_{EH}	: Dead load factor (earth pressure)
	Φ_{LL}	: Live load factor
Resistance factors:	Φ_F	: Resistance factor for flexure
	Φ_V	: Resistance factor for shear
	Φ_N	: Resistance factor for normal force
Design parameters:	N	: Bar number
	s	: Bar spacing
	γ_e	: Exposure factor
	$c_{service}$: Trial value of depth of neutral axis to calculate steel stress under service loads

- What is the output?

The checks which verify whether the entered amount of reinforcement is enough or not are the outputs of this sheet. When all the checks are okay, we make sure that our design is completed.

Reference Manual:

- How calculations are done?

All the calculations are done according to the methods explained in AASHTO LRFD specification.

Procedures followed are also described in detail while calculations are done.

Shrinkage and temperature reinforcement is calculated for wall for each direction (LRFD 4.10.8) and then safety of wall in flexure and shear has been checked as cantilever and fixed-fixed wall parts. There is also restriction over spacing of reinforcement close to tension face dictated by crack control (LRFD 5.7.3.4). Shear capacity of the elements have been calculated according to LRFD 5.8. For flexure of column region, only the minimum limits dictated by LRFD have been given.. Shear check of column is also implemented (LRFD 5.8).

- Example design problem is shown below with sample input/output.

All inputs are in red colour.

All checks are in yellow colour.

This sheet is created to design the type #3 abutment system. Design will be done in two stages. Firstly, the body above socket region, which is from 4ft to the top of abutment, will be designed and then socket region will be analyzed and designed separately. Moreover, design will be carried out for half of the system which includes only one pile and the other half will have same design symmetrically (see Figure 1).

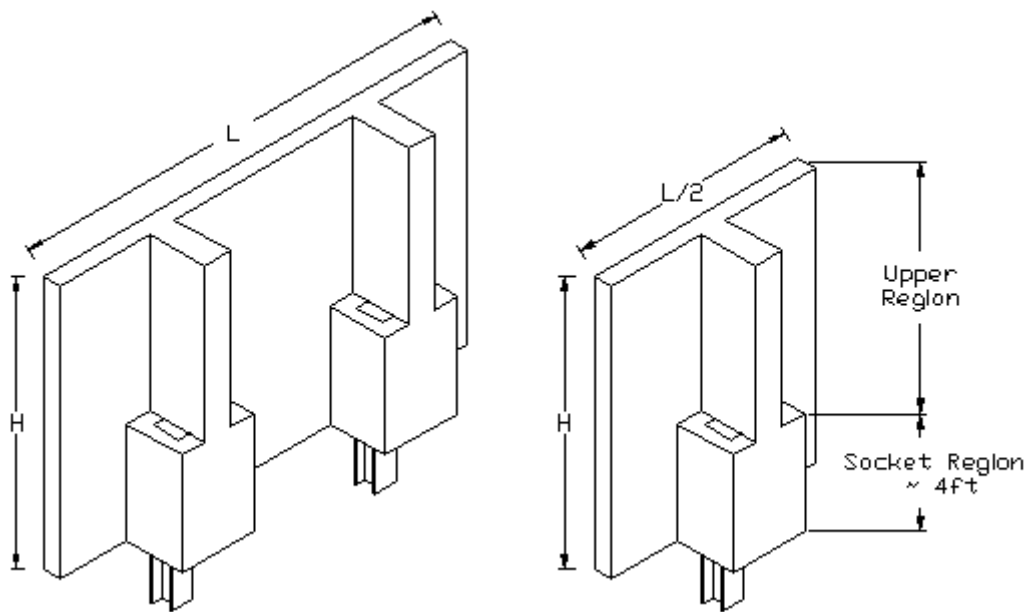

Isometric View
Figure 1

Design Constants:

$$H := 10\text{ft}$$

height of the abutment module.

$$L := 16\text{ft}$$

width of the abutment module.

$$S_{\text{pile}} := \frac{L}{2}$$

pile spacing.

$$t := 8\text{in}$$

thickness of the thin wall

Material Properties:**Concrete:**

$$f_c := 4\text{ksi}$$

ultimate design strength of concrete

$$f_T := 0.37 \sqrt{\frac{f_c}{\text{ksi}}} \text{ksi} = 0.74 \cdot \text{ksi}$$

modulus of rupture of concrete when it is used for minimum reinforcement calculations, (LRFD 5.4.2.6)

$$\beta_1 := \max \left[0.85 - 0.05 \cdot \frac{(f_c - 4\text{ksi})}{\text{ksi}}, 0.65 \right] = 0.85$$

neutral axis multiplier, (LRFD 5.7.2.2)

Steel:

$$f_y := 60\text{ksi}$$

yield strength of reinforcing bars.

$$E_s := 29000\text{ksi}$$

modulus of elasticity of reinforcing bars, (LRFD 5.4.3.2).

$$\epsilon_y := \frac{f_y}{E_s} = 2.069 \times 10^{-3}$$

yield strain of reinforcing bars.

Design of Upper Region:**Flexural Design:**

Hatched cross section is the one that we will be designing for this part.

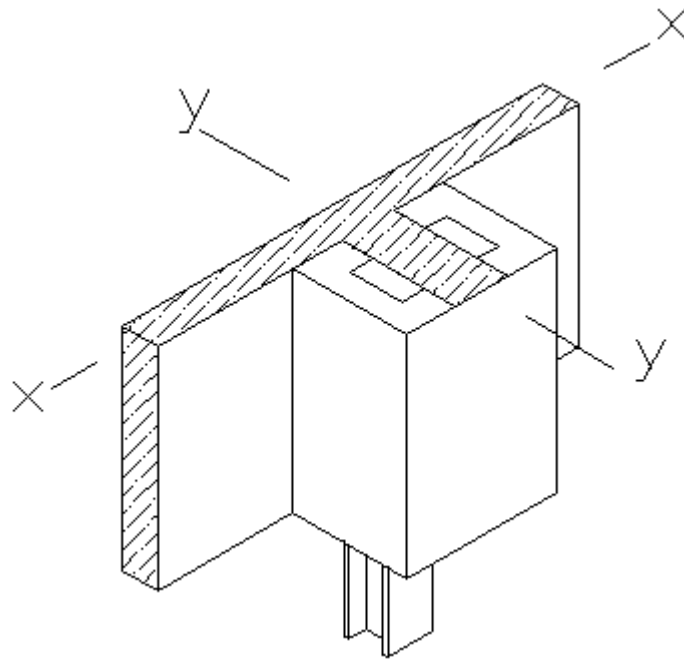

**Isometric View of Socket Region
Figure 2**

Moreover,

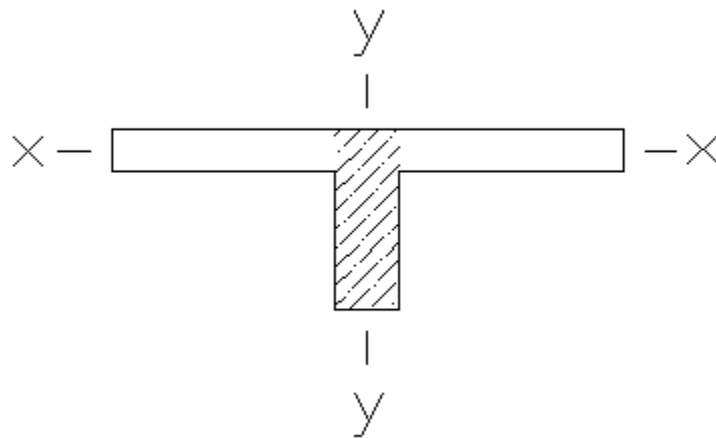

Figure 3

- Hatched region will be designed as column
- Shrinkage and temperature reinforcement will be put in thin wall in both directions and be checked if it has the required capacity for moment due to earth pressure

Please insert the factored forces acting right above the pile top:

$$M := 125 \text{ kip}\cdot\text{ft}$$

factored forces acting on the members from structural analysis

$$N := 150 \text{ kip}$$

$$V := 37 \text{ kip}$$

$$\phi_F := 0.9$$

conventional construction resistance factors for concrete design from LRFD 5.5.4.2.1

$$\phi_V := 0.9$$

$$\phi_N := 0.75$$

resistance factor assuming the section is compression controlled (it is 0.9 for tensioned controlled section). This will be changed based on the section tension reinforcement strain later in design.

Strain in tension reinforcement is 0.002 or less
Strain in tension reinforcement is 0.005 or higher
In between, make linear interpolation

= compression controlled

= tension controlled

$$M_d := \frac{M}{\phi_F} = 138.889 \cdot \text{kip}\cdot\text{ft}$$

$$N_d := \frac{N}{\phi_N} = 200 \cdot \text{kip}$$

$$V_d := \frac{V}{\phi_V} = 41.111 \cdot \text{kip}$$

Shrinkage and Temperature Reinforcement, LRFD 5.10.8:

The area of S&T reinforcement per foot, on each face and in each direction shall not be less than:

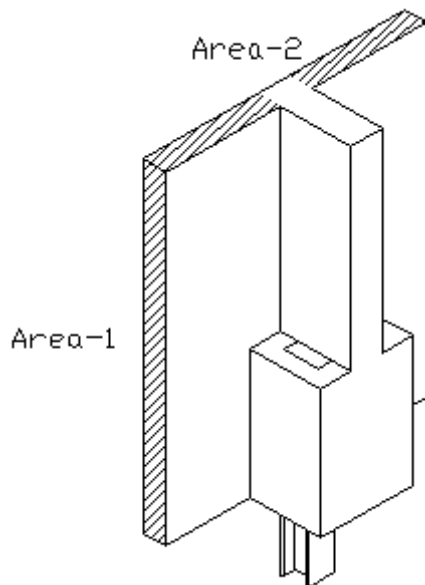

Area 1 is the lateral cross section of the abutment module, whereas Area 2 is the vertical cross section of module.

Figure 4

For Area-1:

$$b := t = 8 \cdot \text{in}$$

$$h := H = 120 \cdot \text{in}$$

$$A_{ST1} := \left[\frac{1.3 \cdot \frac{b}{\text{in}} \cdot \frac{h}{\text{in}}}{2 \cdot \frac{(b+h)}{\text{in}} \cdot \frac{f_y}{\text{ksi}}} \right] \frac{\text{in}^2}{\text{ft}} = 0.081 \cdot \frac{\text{in}^2}{\text{ft}}$$

Furthermore, A_s should satisfy following conditions:

$$A_{ST1} := \begin{cases} 0.11 \frac{\text{in}^2}{\text{ft}} & \text{if } A_{ST1} \leq 0.11 \frac{\text{in}^2}{\text{ft}} \\ 0.6 \frac{\text{in}^2}{\text{ft}} & \text{if } A_{ST1} \geq 0.6 \frac{\text{in}^2}{\text{ft}} \\ A_{ST1} & \text{otherwise} \end{cases} \quad A_{ST1} = 0.11 \cdot \frac{\text{in}^2}{\text{ft}}$$

Maximum spacing can not exceed 3 times the wall thickness or 18in:

$$s_{\max 1} := \min(3 \cdot t, 18 \text{ in}) = 18 \cdot \text{in}$$

Please enter below the rebar number and spacing to get the required area of steel:

$$N := 3$$

$$s := 12 \text{ in}$$

$$A := 2 \left[\frac{12 \text{ in}}{s} \cdot \pi \cdot \left(\frac{N}{16} \text{ in} \right)^2 \right] = 0.221 \cdot \text{in}^2$$

Since we have two faces, we multiplied the reinforcement by two

Therefore, 2#3 @ 12in for this direction of wall is enough.

For Area-2:

$$b := t = 8 \cdot \text{in}$$

$$h := \frac{L}{2} = 96 \cdot \text{in}$$

$$A_{ST1} := \left[\frac{1.3 \cdot \frac{b}{\text{in}} \cdot \frac{h}{\text{in}}}{2 \cdot \frac{(b+h)}{\text{in}} \cdot \frac{f_y}{\text{ksi}}} \right] \frac{\text{in}^2}{\text{ft}} = 0.08 \cdot \frac{\text{in}^2}{\text{ft}}$$

Furthermore, A_s should satisfy following conditions:

$$A_{ST1} := \begin{cases} 0.11 \frac{\text{in}^2}{\text{ft}} & \text{if } A_{ST1} \leq 0.11 \frac{\text{in}^2}{\text{ft}} \\ 0.6 \frac{\text{in}^2}{\text{ft}} & \text{if } A_{ST1} \geq 0.6 \frac{\text{in}^2}{\text{ft}} \\ A_{ST1} & \text{otherwise} \end{cases} \quad A_{ST1} = 0.11 \cdot \frac{\text{in}^2}{\text{ft}}$$

Maximum spacing can not exceed 3 times the wall thickness or 18in:

$$s_{\max 1} := \min(3 \cdot t, 18\text{in}) = 18 \cdot \text{in}$$

Please enter below the rebar number and spacing to get the required area of steel:

$$N := 3$$

$$s := 12\text{in}$$

$$A := 2 \left[\frac{12\text{in}}{s} \cdot \pi \cdot \left(\frac{N}{16} \text{in} \right)^2 \right] = 0.221 \cdot \text{in}^2$$

Since we have two faces, we multiplied the reinforcement by two

Therefore, 2#3 @ 12in for this direction of wall is enough.

Finally, the required area of steel for shrinkage and temperature reinforcement is 2#3 @ 12in for both direction of the wall.

Now, we should check to verify that this amount of reinforcement in the wall is enough for flexure due to earth pressure.

Flexural capacity of the wall will be checked with the maximum pressure assuming it is being applied throughout the wall and clear dimensions will be used.

We have two regions to check the flexural capacity, one is the either side of one module which is acting as cantilever and the other is the middle region which is acting as a beam having two fixed end conditions.

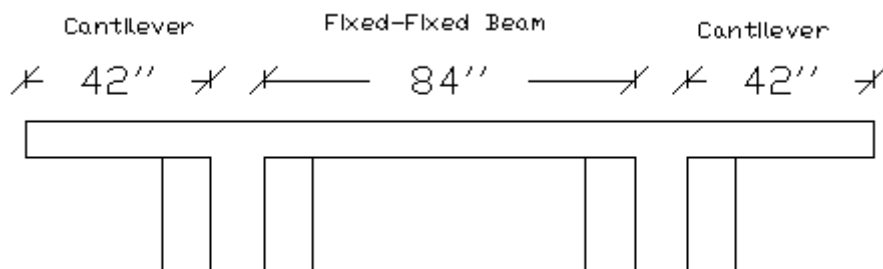

Figure 5

Please enter the unfactored pressure at the bottom of the abutment module (maximum pressure) due to both live load surcharge and lateral earth pressure.

$$p_{LS} := 0.786\text{psi}$$

$$p_{EH} := 2.431\text{psi}$$

$$\phi_{LL} := 1.75$$

live load factor

$$\phi_{EH} := 1.5$$

dead load factor

$$p := \phi_{EH} \cdot p_{EH} + \phi_{LL} \cdot p_{LS} = 5.022 \cdot \text{psi}$$

maximum factored pressure at the bottom of the abutment module

Cantilever wall:

$$M_{\text{cantilever}} := \frac{\left[\left(\frac{L}{4} - \frac{12\text{in}}{2} \right) \cdot H \cdot p \right] \cdot \left[\left(\frac{L}{4} - \frac{12\text{in}}{2} \right) \cdot \frac{1}{2} \right]}{\phi_F} = 49.216 \cdot \text{kip} \cdot \text{ft}$$

$$V_{\text{cantilever}} := \frac{p \cdot \left(\frac{L}{4} - \frac{12\text{in}}{2} \right) \cdot H}{\phi_V} = 28.123 \cdot \text{kip}$$

Flexural check:

Capacity of the wall with S&T reinforcement is:

Pile socket is 2 in inside to the wall, therefore effective thickness of the wall is actually 6 in.

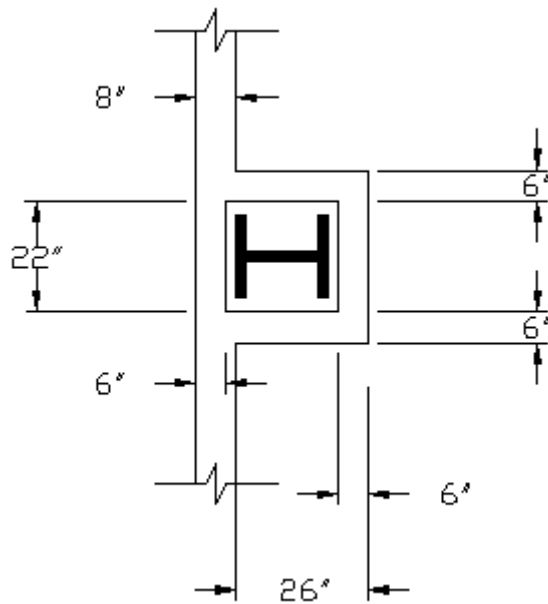

Cross Section View of Bottom of Abutment
Figure 6

$$\text{cover} := 1.5\text{in}$$

clear cover for the reinforcements

$$d := 6\text{in} - \left(\frac{N}{8} \text{in} \cdot \frac{1}{2} \right) = 5.812 \cdot \text{in}$$

$$N_s := \text{floor}\left(\frac{H - 2 \cdot \text{cover}}{s}\right) + 1 = 10$$

number of tension steel (bottom steel)

$$N_{st} := \text{floor}\left(\frac{H - 2 \cdot \text{cover}}{s}\right) + 1 = 10$$

number of compression steel (top steel)

$$A_s := N_s \cdot \pi \cdot \left(\frac{N}{8} \text{ in} \cdot \frac{1}{2}\right)^2 = 1.104 \cdot \text{in}^2$$

bottom steel area (tension steel)

$$A_{st} := N_{st} \cdot \pi \cdot \left(\frac{N}{8} \text{ in} \cdot \frac{1}{2}\right)^2 = 1.104 \cdot \text{in}^2$$

top steel area (compression steel)

$$c_{st} := \text{cover} + \frac{N}{8} \text{ in} \cdot \frac{1}{2} = 1.688 \cdot \text{in}$$

top steel distance from compression fiber

Assume that compression steel is yielded and in tension:

set sum of the forces to zero and get the neutral axis depth:

$$c := 1 \text{ in}$$

initial guess

$$c := \text{root}\left[\left(0.85f_c \cdot H \cdot \beta_1 \cdot c - A_s \cdot f_y - A_{st} \cdot f_y\right), c\right] = 0.382 \cdot \text{in}$$

Now, we should check if the compression steel is in tension and it has yielded as we have assumed:

$$\text{check} := \begin{cases} \text{"Assumption is true"} & \text{if } \left(c < c_{st} - \frac{N}{16} \text{ in}\right) \wedge \left[\frac{(c_{st} - c) \cdot 0.003}{c} > \epsilon_y\right] \\ \text{"Assumption is not true, revise it"} & \text{otherwise} \end{cases}$$

$$\text{check} = \text{"Assumption is true"}$$

$$a := \beta_1 \cdot c = 0.325 \cdot \text{in}$$

$$T_1 := A_s \cdot f_y = 66.268 \cdot \text{kip}$$

force in bottom steel

$$T_2 := A_{st} \cdot f_y = 66.268 \cdot \text{kip}$$

force in top steel

$$M_{\text{capacity}} := T_1 \cdot \left(d - \frac{a}{2} \right) + T_2 \cdot \left(c_{\text{st}} - \frac{a}{2} \right) = 39.624 \cdot \text{kip} \cdot \text{ft}$$

$$\text{capacity} := \begin{cases} \text{"is enough"} & \text{if } \frac{M_{\text{capacity}}}{M_{\text{cantilever}}} \geq 1 \\ \text{"is not enough, change design values"} & \text{otherwise} \end{cases}$$

$$\text{capacity} = \text{"is not enough, change design values "}$$

Since we have used the maximum pressure at the bottom for all over the wall, we got a high moment. Actually, our capacity is enough!

Actual moment for the wall is:

$$p_1 := \phi_{\text{LL}} \cdot p_{\text{LS}} = 1.376 \cdot \text{psi}$$

pressure at the top

$$p_2 := \phi_{\text{EH}} \cdot p_{\text{EH}} + \phi_{\text{LL}} \cdot p_{\text{LS}} = 5.022 \cdot \text{psi}$$

pressure at the bottom

$$Q := \frac{p_1 + p_2}{2} \cdot H \cdot \left(\frac{L}{4} - \frac{12\text{in}}{2} \right) = 16.122 \cdot \text{kip}$$

total force due to pressure distribution

$$M_{\text{actual}} := \frac{Q \cdot \left[\left(\frac{L}{4} - \frac{12\text{in}}{2} \right) \cdot \frac{1}{2} \right]}{\phi_{\text{F}}} = 31.348 \cdot \text{kip} \cdot \text{ft}$$

actual total moment that wall should resist

There is also a restriction over spacing of reinforcement close to tension face which states that spacing can not be larger than the value dictated by crack control, LRFD 5.7.3.4:

$$s \leq \frac{700\gamma_e}{\beta_s \cdot f_{ss}} - 2 \cdot d_c$$

in which:

$$\beta_s := 1 + \frac{d_c}{0.7 \cdot (h - d_c)}$$

where:

γ_e = exposure factor
 = 1 for Class 1 exposure condition
 = 0.75 for Class 2 exposure condition
 (use Class 2 if the element is exposed to water)

d_c = thickness of concrete cover from tension fiber to center of closest reinforcement (in)

f_{ss} = tensile stress in steel at the service limit state (ksi)

h = overall thickness or depth of component (in)

$$\gamma_e := 1$$

$$d_c := 2 \text{ in} + \frac{N}{8} \text{ in} \cdot \frac{1}{2} = 2.188 \text{ in}$$

$$h := t = 8 \text{ in}$$

$$\beta_s := 1 + \frac{d_c}{0.7 \cdot (h - d_c)} = 1.538$$

$$M_{\text{service}} := \frac{[P_{\text{LS}} + (P_{\text{EH}} + P_{\text{LS}})]}{2} \cdot H \cdot \left(\frac{L}{4} - \frac{12\text{in}}{2}\right)^2 = 17.653 \cdot \text{kip} \cdot \text{ft}$$

We will try different neutral axis depths to get the moment of the section same as service moment that we have calculated above:

ignore compression steel!

$$n := 8$$

modular ratio

$$x := 3\text{in}$$

initial guess for neutral axis depth

$$x := \text{root}\left[H \cdot x \cdot \frac{x}{2} - A_s \cdot n \cdot (d - x), x\right]$$

$$x = 0.854 \cdot \text{in}$$

$$I_{\text{cr}} := \frac{1}{3} \cdot H \cdot x^3 + A_s \cdot n \cdot (d - x)^2 = 242.155 \cdot \text{in}^4$$

$$f_{\text{ss}} := \frac{M_{\text{service}} \cdot (d - x)}{I_{\text{cr}}} \cdot n = 34.698 \cdot \text{ksi}$$

$$s_{\text{max}} := \frac{700 \gamma_e}{\beta_s \cdot \frac{f_{\text{ss}}}{\text{ksi}}} \text{in} - 2 \cdot d_c = 8.745 \cdot \text{in}$$

$$s_{\text{max}} := \text{floor}\left(\frac{s_{\text{max}}}{\text{in}}\right) \text{in} = 8 \cdot \text{in}$$

Therefore, the spacing will be 8in which will further increase the flexural capacity!

Shear check, LRFD 5.8:

We need transverse reinforcement if:

$$V_u > 0.5 \cdot \phi \cdot V_c$$

where:

V_u = factored shear force

V_c = nominal shear resistance of the concrete

ϕ = resistance factor specified in 5.5.4.2

Shear strength of concrete, LRFD 5.8.3.3:

$$V_c = 0.0316 \cdot \beta \cdot (f_c)^{0.5} \cdot b_v \cdot d_v$$

$$b_v := H = 10 \cdot \text{ft}$$

effective web width, LRFD 5.8.2.9

$$d_v := \max(0.72 \cdot t, 0.9 \cdot d) = 5.76 \cdot \text{in}$$

effective depth, LRFD 5.8.2.9

since the depth of our wall is less than 16 in, we can use $\beta = 2$, LRFD 5.8.3.4.1

$$\beta := 2$$

$$V_c := \left(0.0316 \cdot \beta \cdot \sqrt{\frac{f_c}{\text{ksi}}} \cdot \frac{b_v}{\text{in}} \cdot \frac{d_v}{\text{in}} \right) \cdot \text{kip} = 87.368 \cdot \text{kip}$$

Now check if we need transverse reinforcement:

$$\text{transverse_reinforcement} := \begin{cases} \text{"is not needed"} & \text{if } V_{\text{cantilever}} \leq 0.5 \cdot \phi_V \cdot V_c \\ \text{"is needed"} & \text{otherwise} \end{cases}$$

$$\text{transverse_reinforcement} = \text{"is not needed"}$$



In case we need transverse reinforcement:

Shear stress on concrete, LRFD 5.8.2.9:

$$V_u := V_{\text{cantilever}} \cdot \phi_V = 25.311 \cdot \text{kip}$$

$$v_u := \frac{V_u}{\phi_V \cdot b_V \cdot d_V} = 0.041 \cdot \text{ksi}$$

Maximum spacing of transverse reinforcement, LRFD 5.8.2.7:

$$s_{\text{max}} := \begin{cases} \min(0.8 \cdot d_V, 24 \text{in}) & \text{if } v_u < 0.125 \cdot f_c \\ \min(0.4 \cdot d_V, 12 \text{in}) & \text{if } v_u \geq 0.125 \cdot f_c \end{cases}$$

$$s_{\text{max}} := \text{floor}\left(\frac{s_{\text{max}}}{\text{in}}\right) \text{in} = 4 \cdot \text{in}$$

Minimum transverse reinforcement, LRFD 5.8.2.5:

We should satisfy at least this amount of transverse reinforcement:

$$A_V > 0.0316 \cdot (f_c)^{0.5} \cdot b_V \cdot s / f_y$$

where:

A_V = area of reinforcement within distance s

b_V = web thickness

s = spacing of reinforcement

$$A_V := 0.0316 \sqrt{\frac{f_c}{\text{ksi}}} \cdot \frac{b_V \cdot s_{\text{max}}}{\frac{f_y}{\text{ksi}}} = 0.506 \cdot \text{in}^2$$



Fixed beam:

$$w := p \cdot H = 7.232 \cdot \frac{\text{kip}}{\text{ft}} \quad \text{distributed load over beam}$$

$$l := \frac{L}{2} - 12\text{in} = 84\text{in} \quad \text{clear length of the beam}$$

$$V_{\text{fixed}} := \frac{w \cdot l}{2} = 25.311 \cdot \text{kip} \quad \text{shear force at the support}$$

$$M_{\text{end}} := \frac{\frac{w \cdot l^2}{12}}{\phi_F} = 32.81 \cdot \text{kip} \cdot \text{ft} \quad \text{moment at the ends}$$

$$M_{\text{center}} := \frac{\frac{w \cdot l^2}{24}}{\phi_F} = 16.405 \cdot \text{kip} \cdot \text{ft} \quad \text{moment at the center}$$

Negative moment resistance at the ends are the same as the resistance that we got for cantilever part and for positive moment resistance our d is slightly increasing which will also increase our capacity. Therefore, since those moments are far lower than our capacity, using the same reinforcement all over the wall region is enough and safe.

$$\text{fixed_wall_capacity} := \begin{cases} \text{"is enough"} & \text{if } M_{\text{capacity}} \geq M_{\text{end}} \wedge M_{\text{center}} \\ \text{"is not enough"} & \text{otherwise} \end{cases}$$

$$\text{fixed_wall_capacity} = \text{"is enough"}$$

For shear design, since the factored shear is the same as the cantilever part, we do not need any transverse reinforcement. The capacity of concrete is enough to carry it.

Design of column region 12in x 34in:

Limits for reinforcement by LRFD 5.7.4.2

$$A_{s_max} := 0.08 \cdot (12\text{in} \cdot 34\text{in}) = 32.64 \cdot \text{in}^2 \quad \text{maximum area of reinforcement}$$

$$A_{s_min} := 0.135 \cdot (12\text{in} \cdot 34\text{in}) \cdot \frac{f_c}{f_y} = 3.672 \cdot \text{in}^2 \quad \text{minimum area of reinforcement}$$

Minimum number is #5 for longitudinal reinforcement.

Taking above limits into account, column should be designed conventionally.

Shear check for column, LRFD 5.8:

We need transverse reinforcement if:

$$V_u > 0.5 \cdot \phi \cdot V_c$$

where:

V_u = factored shear force

V_c = nominal shear resistance of the concrete

ϕ = resistance factor specified in 5.5.4.2

Shear strength of concrete, LRFD 5.8.3.3:

$$V_c = 0.0316 \cdot \beta \cdot (f_c)^{0.5} \cdot b_v \cdot d_v$$

$$b_v := 12\text{in} \quad \text{effective web width, LRFD 5.8.2.9}$$

$$d := 34\text{in} - 1.5\text{in} - \frac{6}{8}\text{in} \cdot \frac{1}{2} = 32.125\text{in}$$

$$d_v := \max[(0.72 \cdot 34\text{in}), (0.9 \cdot d)] = 28.912\text{in} \quad \text{effective depth, LRFD 5.8.2.9}$$

since we will have at least minimum amount of transverse reinforcement, we can use $\beta = 2$, LRFD 5.8.3.4.1

$$\beta := 2$$

$$V_c := \left(0.0316 \cdot \beta \cdot \sqrt{\frac{f_c}{\text{ksi}}} \cdot \frac{b_v}{\text{in}} \cdot \frac{d_v}{\text{in}} \right) \cdot \text{kip} = 43.854 \cdot \text{kip}$$

$$V_u := V = 37 \cdot \text{kip}$$

shear_check := $\begin{cases} \text{"put minimum transverse reinf"} & \text{if } 0.5 \cdot \phi_V \cdot V_c \geq V_u \\ \text{"recalculate the strength putting transverse reinf"} & \text{otherwise} \end{cases}$

shear_check = "recalculate the strength putting transverse reinf"

We will put minimum amount of transverse reinforcement into column and check the strength, LRFD 5.8.2.5:

Shear stress on concrete, LRFD 5.8.2.9:

$$v_u := \frac{V_u}{\phi_V \cdot b_v \cdot d_v} = 0.118 \cdot \text{ksi}$$

Maximum spacing of transverse reinforcement, LRFD 5.8.2.7:

$$s_{\max} := \begin{cases} \min(0.8 \cdot d_v, 24 \text{in}) & \text{if } v_u < 0.125 \cdot f_c \\ \min(0.4 \cdot d_v, 12 \text{in}) & \text{if } v_u \geq 0.125 \cdot f_c \end{cases} = 23.13 \cdot \text{in}$$

$$s_{\max} := \text{floor}\left(\frac{s_{\max}}{\text{in}}\right) \text{in} = 23 \cdot \text{in}$$

Please enter the desired transverse reinforcement number and spacing below:

$$N := 3$$

$$s := 10 \text{in}$$

should be lesser than the maximum value that is found above

$$A_v := 2 \cdot \pi \cdot \left(\frac{N}{8} \cdot \text{in} \cdot \frac{1}{2} \right)^2 = 0.221 \cdot \text{in}^2$$

$$A_{v_min} := 0.0316 \cdot \sqrt{\frac{f_c}{\text{ksi}}} \cdot \frac{b_v \cdot s}{\frac{f_y}{\text{ksi}}} = 0.126 \cdot \text{in}^2$$

$$\text{transverse_reinforcement} := \begin{cases} \text{"is enough for minimum amount"} & \text{if } \frac{A_v}{A_{v_min}} \geq 1 \\ \text{"is not enough for minimum amount"} & \text{otherwise} \end{cases}$$

transverse_reinforcement = "is enough for minimum amount"

Strength contribution of transverse reinforcement, LRFD 5.8.3.3:

Since the transverse reinforcement is inclined with 90 degrees to longitudinal reinforcement, equation reduces to:

$$V_s := \frac{A_v \cdot f_y \cdot d_v \cdot \cot(\theta)}{s}$$

where:

θ = angle of inclination of diagonal compressive stresses as in LRFD 5.8.3.4

Since we have at least minimum transverse reinforcement, we can use $\theta = 45$ degree

$$\theta := 45 \text{deg}$$

$$V_s := \frac{A_v \cdot f_y \cdot d_v \cdot \cot(\theta)}{s} = 38.319 \cdot \text{kip}$$

$$V_n := \min(V_c + V_s, 0.25 \cdot f_c \cdot b_v \cdot d_v)$$

nominal shear strength of the section, LRFD 5.8.3.3

$$V_n = 82.174 \cdot \text{kip}$$

$$\text{shear_strength} := \begin{cases} \text{"is enough"} & \text{if } V_u \leq \phi_V \cdot V_n \\ \text{"is not enough"} & \text{otherwise} \end{cases}$$

shear_strength = "is enough"

Reference Manual:

- How calculations are done?

All the calculations are done according to the methods explained in AASHTO LRFD specification. Procedures followed are also described in detail while calculations are done. For example, LRFD 3.11.6.4 is utilized for live load surcharge calculations(LS) and LRFD 3.11.5 is utilized for earth pressure calculations(EH).

- Example design problem is shown below with sample input/output.

All inputs are in red colour.

Results are in yellow colour.

Isometric drawing of the system can be seen below.

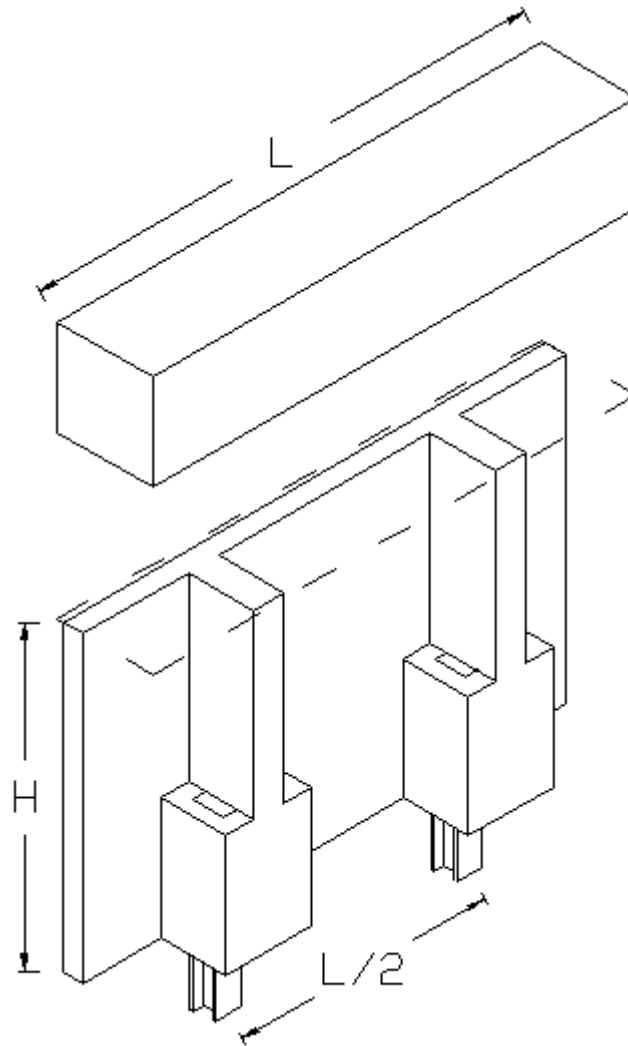

Isometric View
Figure 1

Design Constants:

$$H := 10\text{ft}$$

height of the abutment module

$$L := 16\text{ft}$$

width of the abutment module

$$S_{\text{pile}} := \frac{L}{2}$$

pile spacing

$$l_{\text{emb}} := 2\text{ft}$$

embedment length of the pile

Material Properties:Concrete:

$$f_c := 4\text{ksi}$$

ultimate design strength of concrete

$$f_T := 0.37 \sqrt{\frac{f_c}{\text{ksi}}} \text{ksi} = 0.74 \cdot \text{ksi}$$

modulus of rupture of concrete when it is used for minimum reinforcement calculations, (LRFD 5.4.2.6)

Calculation of Design Loads:

There are two major load types that should be considered in the design of abutment which are:

- 1) Horizontal earth pressure which is caused by fill and live load surcharge from vehicles.
- 2) Vertical load coming from superstructure.

Loads Due to Lateral Earth Pressure:

While designing the abutment under lateral loads, loads acting on half of the abutment is thought to be resisted by one pile region. This is reasonable since each abutment module is manufactured by two piles symmetrically.

This part of load calculation is divided into two:

- 1) Live load surcharge due to vehicle load
- 2) Load due to lateral earth pressure

1) Live Load Surcharge LS, (LRFD 3.11.6.4):

The procedure used to calculate the wall's horizontal loading due to live load surcharge from vehicular wheel load on the backfill is as follows:

$$\Delta_s = k \cdot \gamma_s \cdot h_{eq}$$

constant horizontal earth pressure due to live load surcharge (ksf)

$$\gamma_s := 0.127 \frac{\text{kip}}{\text{ft}^3}$$

total unit weight of soil (kcf)

k

coefficient of lateral earth pressure

k_o will be used if the wall does not deflect, (LRFD Article 3.11.5.2)

k_a will be used if the wall deflects, (LRFD 3.11.5.3, 3.11.5.6 and 3.11.5.7)

h_{eq}

equivalent height of soil for vehicular load (ft.)

Equivalent height of soil for vehicular loading on abutments perpendicular to traffic is as follows, (LRFD Table 3.11.6.4-1):

$$h_{eq} := \begin{cases} 4\text{ft} & \text{if } H \leq 5\text{ft} \\ 4\text{ft} - \frac{(H - 5\text{ft})}{5} & \text{if } 5\text{ft} < H \leq 10\text{ft} \\ 3\text{ft} - \frac{(H - 10\text{ft})}{10} & \text{if } 10\text{ft} < H < 20\text{ft} \\ 2\text{ft} & \text{if } H \geq 20\text{ft} \end{cases}$$

$$h_{eq} = 3 \cdot \text{ft}$$

Calculation of k_a according to LRFD 3.11.5.3:

$$\delta := 30\text{deg}$$

friction angle between fill and wall taken as specified in LRFD Table 3.11.5.3-1

$$\beta := 0\text{deg}$$

angle of fill to the horizontal as shown in LRFD Figure 3.11.5.3-1

$$\theta := 90\text{deg}$$

angle of back face of wall to the horizontal as shown in LRFD Figure 3.11.5.3-1

$$\phi_f := 30\text{deg}$$

effective angle of integral friction angle to be determined by laboratory or site investigations

$$\Gamma := \left(1 + \sqrt{\frac{\sin(\phi_f + \delta) \cdot \sin(\phi_f - \beta)}{\sin(\theta - \delta) \cdot \sin(\theta + \beta)}} \right)^2 = 2.914 \quad \text{LRFD equation 3.11.5.3-2}$$

$$k_a := \frac{\sin(\theta + \phi_f)^2}{\Gamma \cdot \sin(\theta)^2 \cdot \sin(\theta - \delta)} = 0.297 \quad \text{LRFD equation 3.11.5.3-1}$$

Calculation of k_o according to LRFD 3.11.5.2:

$$k_o := 1 - \sin(\phi_f) = 0.5 \quad \text{LRFD equation 3.11.5.2-1}$$

Insert the value of wall below as 1 if the wall deflects or 0 if the wall does not deflect:

$$\text{wall} := 1$$

$$k := \begin{cases} k_a & \text{if wall} = 1 \\ k_o & \text{if wall} = 0 \end{cases} \quad k = 0.297$$

First of all, forces just above the pile will be found. Column above pile socket will be designed with those forces. Additionally, applying these forces on the cheeks of socket region, another design will be implemented for socket and pile interaction region.

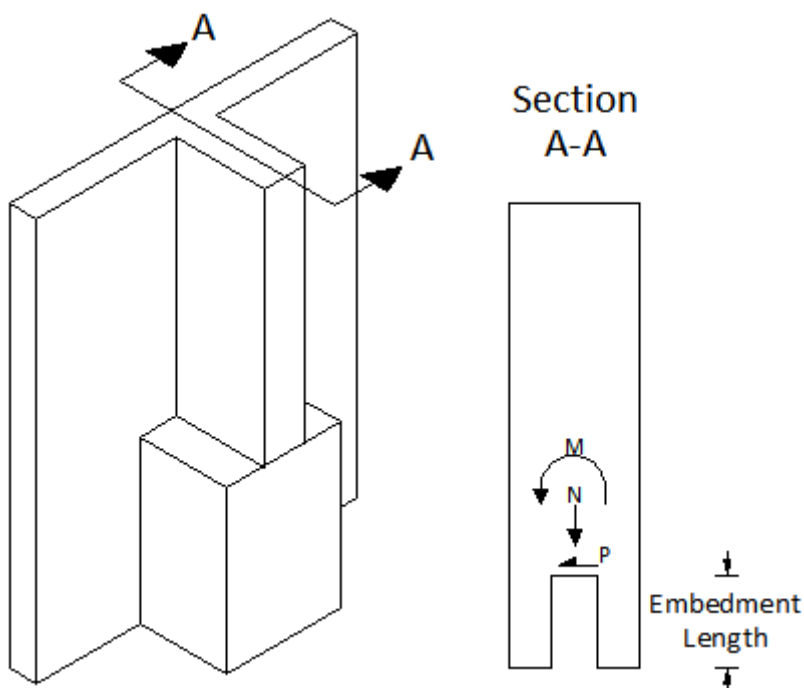

Figure 2

$$\phi_{LL} := 1.75$$

LL load factor, LRFD Table 3.4.1-1

$$p_{LS} := k \cdot h_{eq} \cdot \gamma_s = 0.786 \cdot \text{psi}$$

maximum live load surcharge pressure

$$V_1 := k \cdot h_{eq} \cdot \gamma_s \cdot H \cdot \frac{L}{2} = 9.058 \cdot \text{kip}$$

unfactored shear force per one pile

$$M_1 := V_1 \cdot \left(\frac{H}{2} - l_{emb} \right) = 27.173 \cdot \text{kip} \cdot \text{ft}$$

unfactored moment over pile per pile (since the pressure distribution is constant, moment arm is the half of the pressure distribution height minus embedment length)

$$\phi V_1 := V_1 \cdot \phi_{LL} = 15.851 \cdot \text{kip}$$

factored shear force per pile due to live load surcharge

$$\phi M_1 := M_1 \cdot \phi_{LL} = 47.554 \cdot \text{kip} \cdot \text{ft}$$

factored moment over socket region per pile due to live load surcharge

2) Loads Due to Lateral Earth Pressure EH, (LRFD 3.11.5):

A second source of load on the wall is earth pressures:

$$\phi_{EH} := \begin{cases} 1.5 & \text{if } k = k_a \\ 1.35 & \text{if } k = k_o \end{cases}$$

load factor is 1.5 if k_a is used, or 1.35 if k_o is used in calculations, LRFD Table 3.4.1-2

$$\phi_{EH} = 1.5$$

While calculating the earth pressure behind the abutment wall, we will use Equivalent-Fluid Method of Estimating Rankine Lateral Earth Pressures method explained in LRFD 3.11.5.5. Please note also that this method can only be applied when we have free draining backfill. Here, we assume that the drainage methods will be applied at the site to get rid of water table behind the wall.

$$p = \gamma_{eq} \cdot z$$

basic earth pressure behind the wall (ksf)

$$\gamma_{eq}$$

equivalent fluid unit weight of soil, not less than 0.03 kcf

$$z$$

depth below surface of soil (ft)

For medium dense sand or gravel, wall height not exceeding 20ft and with a level backfill:

$$\gamma_{eq} := \begin{cases} 0.035 \frac{\text{kip}}{\text{ft}^3} & \text{if } k = k_a \\ 0.05 \frac{\text{kip}}{\text{ft}^3} & \text{if } k = k_o \end{cases}$$

equivalent unit weight of backfill,
LRFD Table 3.11.5.5-1

$$\gamma_{eq} = 0.035 \cdot \frac{\text{kip}}{\text{ft}^3}$$

$$p_{EH} := \gamma_{eq} \cdot H = 2.431 \cdot \text{psi}$$

maximum earth pressure at the
bottom of abutment module

$$V_2 := \frac{(\gamma_{eq} \cdot H) \cdot H}{2} \cdot \frac{L}{2} = 14 \cdot \text{kip}$$

unfactored resultant shear per
one pile

$$M_2 := V_2 \cdot \left(\frac{H}{3} - l_{emb} \right) = 18.667 \cdot \text{kip} \cdot \text{ft}$$

unfactored moment at the top of
pile socket region per pile, since
the distribution is triangular,
moment arm is the one third of the
relevant height

$$\phi V_2 := V_2 \cdot \phi_{EH} = 21 \cdot \text{kip}$$

factored resultant shear due to
lateral earth pressure per pile

$$\phi M_2 := M_2 \cdot \phi_{EH} = 28 \cdot \text{kip} \cdot \text{ft}$$

factored moment at the top of
socket region per pile

Total design loads due to earth pressures (LS+EH) per pile:

Unfactored service loads:

Factored loads:

$$V := V_1 + V_2 = 23.058 \cdot \text{kip}$$

$$\phi V := \phi V_1 + \phi V_2 = 36.851 \cdot \text{kip}$$

$$M := M_1 + M_2 = 45.84 \cdot \text{kip} \cdot \text{ft}$$

$$\phi M := \phi M_1 + \phi M_2 = 75.554 \cdot \text{kip} \cdot \text{ft}$$

Vertical Load Coming From Superstructure:

There is an eccentricity of the normal forces coming from superstructure (girder reactions) since the bearing pads of the girders are not placed in the middle of the pilecap (see Figure 3). This eccentricity causes additional moment on the cross section that we are dealing and on the pile also. In this section we will also add those loads to our calculations.

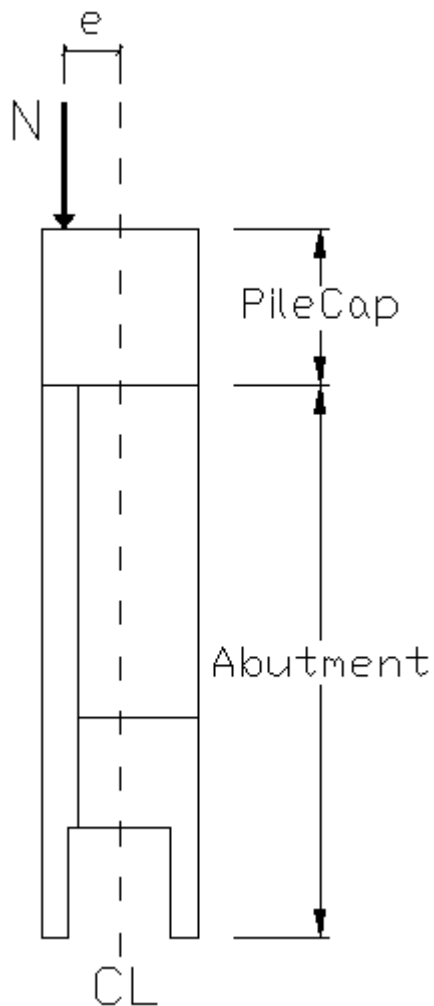

Please insert the sum of normal loads coming from superstructure acting on one abutment module as DL and LL separately.

$$N_{DL} := 70\text{kip}$$

$$N_{LL} := 80\text{kip}$$

Please insert the eccentricity between the centerline of bearing pads and the centerline of bent cap module as shown on Figure 3.

$$e := 2\text{in}$$

Figure 3

Below is the cross section of the abutment part per pile, using those dimensions, we will find the moment of inertia and the section modulus.

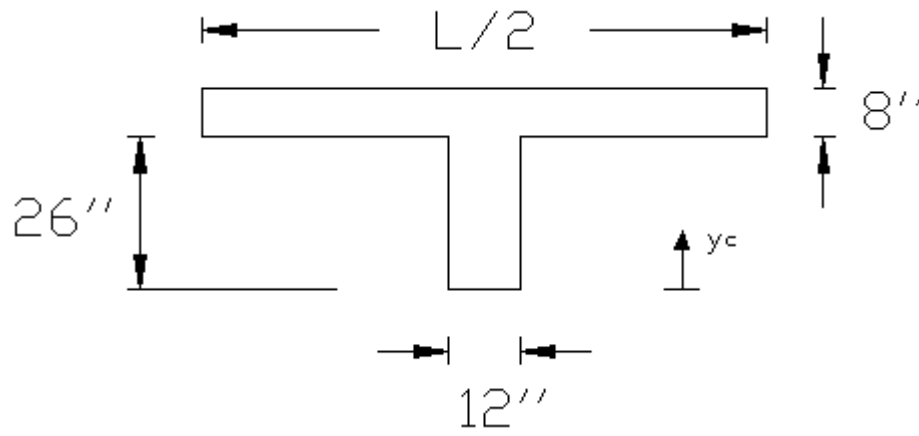

Figure 4

$$y_c := \frac{\frac{L}{2} \cdot 8 \text{ in} \cdot 30 \text{ in} + 12 \text{ in} \cdot 26 \text{ in} \cdot 13 \text{ in}}{\frac{L}{2} \cdot 8 \text{ in} + 12 \text{ in} \cdot 26 \text{ in}} = 25.089 \cdot \text{in}$$

distance between center of gravity of the section and the tension fiber

$$I := \left[\frac{1}{12} \cdot \frac{L}{2} \cdot (8 \text{ in})^3 + \frac{L}{2} \cdot 8 \text{ in} \cdot (30 \text{ in} - y_c)^2 \right] + \left[\frac{1}{12} \cdot 12 \text{ in} \cdot (26 \text{ in})^3 + 12 \text{ in} \cdot 26 \text{ in} \cdot (y_c - 13 \text{ in})^2 \right]$$

$$I = 8.579 \times 10^4 \cdot \text{in}^4$$

moment of inertia of the section per pile

$$\phi_{DL} := 1.25$$

load factor for DL, LRFD Table 3.4.1-2

$$N := \frac{N_{DL} + N_{LL}}{2} = 75 \cdot \text{kip}$$

total unfactored normal load on abutment per pile

$$\phi N := \frac{N_{DL} \cdot \phi_{DL} + N_{LL} \cdot \phi_{LL}}{2}$$

total factored normal load on abutment per pile

$$\phi N = 113.75 \cdot \text{kip}$$

$$M_e := N \cdot e = 12.5 \cdot \text{kip} \cdot \text{ft}$$

unfactored moment due to eccentricity per pile

$$M := M + M_e = 58.34 \cdot \text{kip} \cdot \text{ft}$$

unfactored total moment

$$\phi M_e := \phi N \cdot e = 18.958 \cdot \text{kip} \cdot \text{ft}$$

factored moment due to eccentricity per pile

$$\phi M := \phi M + \phi M_e = 94.512 \cdot \text{kip} \cdot \text{ft}$$

final factored moment

We should also add the self weight of the abutment and bent cap:

$$N_{\text{abutment}} := \frac{(L \cdot 8 \text{ in} + 26 \text{ in} \cdot 12 \text{ in} \cdot 2) \cdot H \cdot 0.15 \frac{\text{kip}}{\text{ft}^3}}{2}$$

$$N_{\text{abutment}} = 11.25 \cdot \text{kip}$$

normal force coming from self weight of the abutment per pile

Please insert the weight of the bent cap:

$$N_{\text{cap}} := 30 \text{ kip}$$

Then, the final normal force and moment are:

$$N := \left(N_{\text{abutment}} + \frac{N_{\text{cap}}}{2} \right) + N = 101.25 \cdot \text{kip}$$

unfactored normal force per pile acting on the center of gravity of the section

$$\phi N := \left(N_{\text{abutment}} + \frac{N_{\text{cap}}}{2} \right) \cdot \phi_{\text{DL}} + \phi N = 146.563 \cdot \text{kip}$$

factored normal force per pile acting on the center of gravity of the section

Further requirements on design moment for flexure, LRFD 5.7.3.3.2:

The design moment can not be lower than the lesser of 1.2 times the cracking moment and 1.33 times the required strength moment (minimum moment usually controls for thick abutments).

$$S_c := \frac{I}{y_c}$$

section modulus of the cross section for the tension fiber per pile

$$M_c := S_c \cdot f_T = 210.869 \cdot \text{kip} \cdot \text{ft}$$

cracking moment of the section per pile

Therefore, our final factored(design) moment is as follows:

$$\phi M := \max(\phi M, \min(1.2 \cdot M_c, 1.33 \cdot \phi M)) = 125.701 \cdot \text{kip} \cdot \text{ft}$$

Total forces over pile socket per pile are as follows:

Unfactored:

$$N = 101.25 \cdot \text{kip}$$

$$V = 23.058 \cdot \text{kip}$$

$$M = 58.34 \cdot \text{kip} \cdot \text{ft}$$

Factored:

$$\phi N = 146.563 \cdot \text{kip}$$

$$\phi V = 36.851 \cdot \text{kip}$$

$$\phi M = 125.701 \cdot \text{kip} \cdot \text{ft}$$

New Design Examples

Load Calculation Sheet for Pier Bent Cap

Users Guide:

- What does program do?

This design force calculation sheet determines the unfactored forces required for the design of pier bent cap module for a specific example bridge. Some parts of this example sheet needs manual changes as inputs. Type of forces in example are:

Dead Load
 Wearing Load
 Live Load
 Braking Force
 Thermal Forces
 Wind Load
 On Structures
 On Vehicles
 On Substructures

- What input is required?

Dimensions & Design Parameters:

L	: Bridge span length
W	: Bridge width
Span	: Number of spans
Parapet	: Parapet height
W_{parapet}	: Parapet self weight
H_{girder}	: Girder height
S_g	: Girder spacing
W_{girder}	: Girder self weight
Φ_{pier}	: Diameter of piers
L_{pier}	: Length of piers
N_{pier}	: Number of piers
W_{cap}	: Pile cap width
H_{cap}	: Depth of pile cap
L_{cap}	: Length of pile cap
$R_{1TR}-R_{5TR}$: Reaction from axle over pier (controlling case)
μ_{max}	: Maximum coefficient of friction
μ_{min}	: Minimum coefficient of friction
V_B	: Wind base design velocity
P_B	: Wind base pressure

- What is the output?

All forces in the direction of longitudinal and transverse required to design pier cap have been calculated as an output from this sheet.

Reference Manual:

- How calculations are done?
All the calculations are done according to the methods explained in AASHTO LRFD specification. Procedures followed are also described in detail while calculations are done.
- Example design problem is shown below with sample input/output.

All inputs are in red color.

All checks are in yellow color.

Design Constants:

Superstructure:

$$L := 90\text{ft}$$

bridge span length

$$W := 42\text{ft}$$

bridge width

$$\text{Span} := 3$$

number of spans

$$\text{Parapet} := 2\text{ft}$$

parapet height

$$W_{\text{parapet}} := 45 \frac{\text{lbf}}{\text{ft}}$$

parapet self weight

$$N_{\text{lanes}} := \text{floor}\left(\frac{W}{12\text{ft}}\right) = 3$$

number of lanes

Girders:

Using Wisconsin Bridge Manual, we can estimate the beam size and spacing as follows:

From table 19.1a:
For L=90ft

$$H_{\text{girder}} := 45\text{in}$$

girder height

$$S_g := 9\text{ft}$$

girder spacing

$$s := \text{floor}\left(\frac{W}{S_g}\right) = 4$$

number of spacings

$$N_g := s + 1 = 5$$

number of girders

$$W_{\text{girder}} := 583 \frac{\text{lbf}}{\text{ft}}$$

girder self weight

$$t_{\text{deck}} := \frac{S_g + 10\text{ft}}{30} = 7.6\text{in}$$

AASHTO slab thickness,
T2.5.2.6.3-1

$$t_{\text{deck}} := \begin{cases} t_{\text{deck}} & \text{if } t_{\text{deck}} \geq 8\text{in} \\ (8\text{in}) & \text{if } t_{\text{deck}} < 8\text{in} \end{cases}$$

for durability use at least 8 in.

$$t_{\text{deck}} = 8\text{in}$$

$$OH := \frac{[W - S_g \cdot (N_g - 1)]}{2} = 3 \cdot \text{ft}$$

cantilever part of the width of the bridge (overhang)

Substructure:

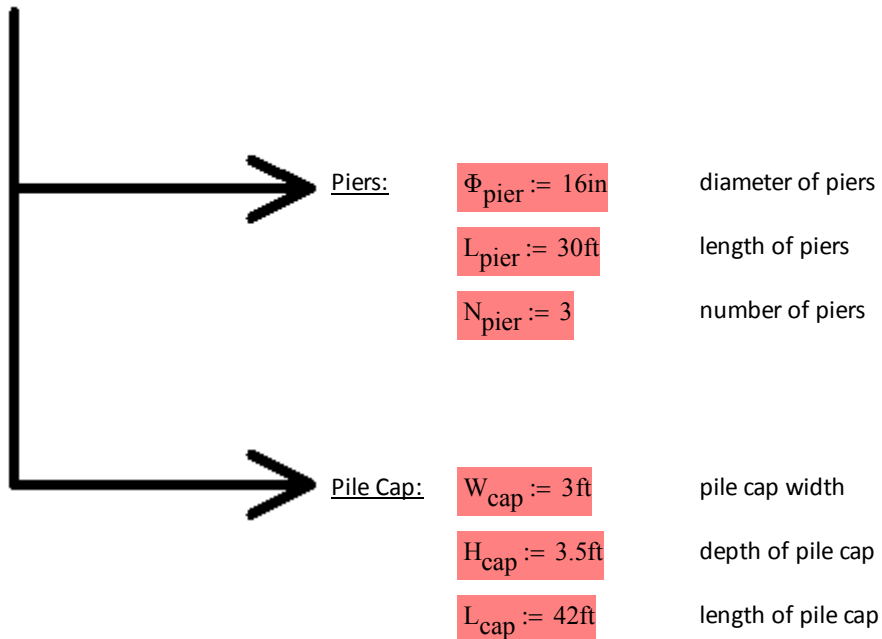

Dead Load Per Girder Per Linear Foot:

$$DL_{\text{girder}} := W_{\text{girder}} = 583 \cdot \frac{\text{lb}}{\text{ft}}$$

dead load on girder due to its self weight

$$DL_{\text{deck}} := \left(150 \frac{\text{lb}}{\text{ft}^3} \right) \cdot t_{\text{deck}} \cdot S_g = 900 \cdot \frac{\text{lb}}{\text{ft}}$$

dead load on girder due to deck self weight, using the same load for the exterior girders (conservative)

$$DL_{\text{parapet}} := \frac{2 \cdot (W_{\text{parapet}})}{N_g} = 18 \cdot \frac{\text{lb}}{\text{ft}}$$

dead load on girder due to weight of parapet

$$DL_{\text{per_girder}} := DL_{\text{girder}} + DL_{\text{deck}} + DL_{\text{parapet}} = 1.501 \cdot \frac{\text{kip}}{\text{ft}}$$

total dead load plf on girder

Dead Load Reactions On Pier Caps Due To Girders:

Bridge spans will be simply supported beams until deck is poured.

$$P_{\text{intDL}} := 2 \left(\frac{DL_{\text{per_girder}} \cdot L}{2} \right) = 135.09 \cdot \text{kip}$$

point dead load under one girder support on pier (interior)

$$P_{\text{extDL}} := \frac{DL_{\text{per_girder}} \cdot L}{2} = 67.545 \cdot \text{kip}$$

point dead load under one girder support on abutment (exterior)

Wearing Load:

$$SW_{\text{wearing}} := 20 \text{psf}$$

self weight of wearing surface per square foot

$$DL_{\text{wearing}} := SW_{\text{wearing}} \cdot S_g = 180 \cdot \text{plf}$$

assuming equal distribution to the beams

Dead Load Reactions On Pier Caps Due To Weight of Wearing:
Again, spans are simply supported.

$$P_{\text{intWL}} := 2 \cdot \left(\frac{DL_{\text{wearing}} \cdot L}{2} \right) = 16.2 \cdot \text{kip}$$

point wearing load under one girder support on pier (interior)

$$P_{\text{extWL}} := \frac{DL_{\text{wearing}} \cdot L}{2} = 8.1 \cdot \text{kip}$$

point wearing load under one girder support on abutment (exterior)

Live Load:

Loadings for the pier cap coming from live load will be determined in such a way that it is causing the largest moment and shear in one side of the cap.

We want the loads that exist simultaneously on the structure, for that reason, we will use AASHTO C4.6.2.2.2d (stiff diaphragms or cross frames). This method would only be applied to axles not over the pier.

And, we will do SAP analysis to calculate the forces coming from axles over the pier.

Axles on span:

The distribution of loads to the beams is calculated as follows:

$$R_j := \frac{N_L}{N_B} + \left(x_j \cdot \frac{\sum e_j}{\sum x_j^2} \right)$$

LRFD C.4.6.2.2.2d-1

where:

N_L = number of lanes loaded

N_B = number of beams

x_j = distance from CL of cap to j'th beam

e_j = eccentricity of lane j from CL of cap

$$N_B := N_g = 5$$

Since lanes can be moved over the span of the cap, we move all lanes adjacent to each other to the left of the cap to create the maximum moment on cap.

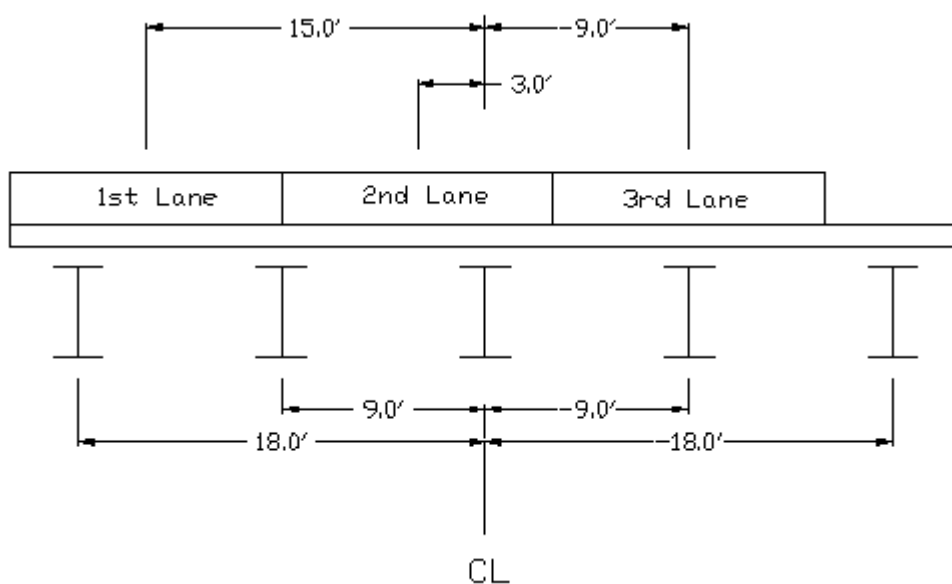

Eccentricities:

$$e_1 := 15\text{ft}$$

first lane's eccentricity

$$e_2 := 3\text{ft}$$

second lane's eccentricity

$$e_3 := -9\text{ft}$$

third lane's eccentricity

$$x_1 := \frac{W}{2} - OH = 18\cdot\text{ft}$$

leftmost girder's eccentricity

$$x_2 := x_1 - S_g = 9\cdot\text{ft}$$

$$x_3 := x_2 - S_g = 0\cdot\text{ft}$$

middle girder's eccentricities

$$x_4 := x_3 - S_g = -9\cdot\text{ft}$$

$$x_5 := x_4 - S_g = -18\cdot\text{ft}$$

rightmost girder's eccentricity

$$a := x_1^2 + x_2^2 + x_3^2 + x_4^2 + x_5^2$$

Sum of squares of the girder eccentricities

One lane loaded:

$$R_{11} := \frac{1}{N_B} + \left(x_1 \cdot \frac{e_1}{a} \right) = 0.533$$

leftmost girder's distribution factor

$$R_{12} := \frac{1}{N_B} + \left(x_2 \cdot \frac{e_1}{a} \right) = 0.367$$

$$R_{13} := \frac{1}{N_B} + \left(x_3 \cdot \frac{e_1}{a} \right) = 0.2$$

middle girder's distribution factor

$$R_{14} := \frac{1}{N_B} + \left(x_4 \cdot \frac{e_1}{a} \right) = 0.033$$

$$R_{15} := \frac{1}{N_B} + \left(x_5 \cdot \frac{e_1}{a} \right) = -0.133$$

rightmost girder's distribution factor

$$R_{11} + R_{12} + R_{13} + R_{14} + R_{15} = 1$$

check to see all DF's sum up to 1

Moment created by the girder reactions with respect to the CL of the cap including multi presence factor is:

$$M_1 := 1.2[(R_{11} - R_{15}) \cdot 2S_g + (R_{12} - R_{14})S_g] \cdot 32\text{kip} = 576 \cdot \text{kip} \cdot \text{ft}$$

Two lanes loaded:

In this case, multi presence factor is 1.

$$R_{21} := \frac{2}{N_B} + \left(x_1 \cdot \frac{e_1 + e_2}{a} \right) = 0.8$$

$$R_{22} := \frac{2}{N_B} + \left(x_2 \cdot \frac{e_1 + e_2}{a} \right) = 0.6$$

$$R_{23} := \frac{2}{N_B} + \left(x_3 \cdot \frac{e_1 + e_2}{a} \right) = 0.4$$

$$R_{24} := \frac{2}{N_B} + \left(x_4 \cdot \frac{e_1 + e_2}{a} \right) = 0.2$$

$$R_{25} := \frac{2}{N_B} + \left(x_5 \cdot \frac{e_1 + e_2}{a} \right) = 0$$

$$R_{21} + R_{22} + R_{23} + R_{24} + R_{25} = 2$$

check to see all DF's sum up to 2 since we have loaded two lanes

Moment created by the girder reactions with respect to the CL of the cap including multi presence factor is:

$$M_2 := [(R_{21} - R_{25}) \cdot 2S_g + (R_{22} - R_{24})S_g] \cdot 64\text{kip} = 1.152 \times 10^3 \cdot \text{kip} \cdot \text{ft}$$

Three lanes loaded:

Multi presence factor is 0.85.

$$R_{31} := \frac{3}{N_B} + \left(x_1 \cdot \frac{e_1 + e_2 + e_3}{a} \right)$$

$$R_{32} := \frac{3}{N_B} + \left(x_2 \cdot \frac{e_1 + e_2 + e_3}{a} \right)$$

$$R_{33} := \frac{3}{N_B} + \left(x_3 \cdot \frac{e_1 + e_2 + e_3}{a} \right)$$

$$R_{34} := \frac{3}{N_B} + \left(x_4 \cdot \frac{e_1 + e_2 + e_3}{a} \right)$$

$$R_{35} := \frac{3}{N_B} + \left(x_5 \cdot \frac{e_1 + e_2 + e_3}{a} \right)$$

$$R_{31} + R_{32} + R_{33} + R_{34} + R_{35} = 3$$

check to see all DF's sum up to 3 since we have loaded three lanes

Moment created by the girder reactions with respect to the CL of the cap including multi presence factor is:

$$M_3 := 0.85 \left[(R_{31} - R_{35}) \cdot 2S_g + (R_{32} - R_{34}) S_g \right] \cdot 96 \text{kip} = 734.4 \cdot \text{kip} \cdot \text{ft}$$

The governing loading case is the one that has the biggest moment in the pier cap, therefore:

$$\max(M_1, M_2, M_3) = 1.152 \times 10^3 \cdot \text{kip} \cdot \text{ft}$$

Two lanes loaded case governs!

We should also find how much percent of the axle load located on span will go to pier. To do that, we can use SAP and proportion the applied load and the result as follows:

Thinking of the second support from the left:

Case 1:

If we put unit load 14 ft to the left and another unit load 4 ft to the right of the support, we get distribution factors for them respectively:

$$DF_1 := 0.99 \quad \text{for the load 14 ft to the left}$$

$$DF_2 := 0.99 \quad \text{for the load 4 ft to the right}$$

Case 2:

If we put unit load 4 ft to the left and another unit load 14 ft to the right of the support, we get distribution factors for them respectively:

$$D_3 := 1.01 \quad \text{for the load 4 ft to the left}$$

$$D_4 := 0.93 \quad \text{for the load 14 ft to the right}$$

Moreover, 14 ft away load is 32 kip and 4 ft away load is 8 kip, therefore, first case is more critical. Putting 32 kip wheel load 14 ft to the left and 8 kip load 4 ft to the right yields more critical result.

For tandem, we can use the highest factor which is for 4 ft away load:

$$DF_{\text{tandem}} := 1.01$$

Axle over pier:

Now, we should find the case of axle over pier using SAP.

Case 1: Left wheel of the one of the truck is on the leftmost girder

Distances of the wheels from the left side of the deck are:

First wheel 3ft

Second wheel 9ft

Third wheel 14ft

Fourth wheel 20ft

Arrangement of loading and results are:

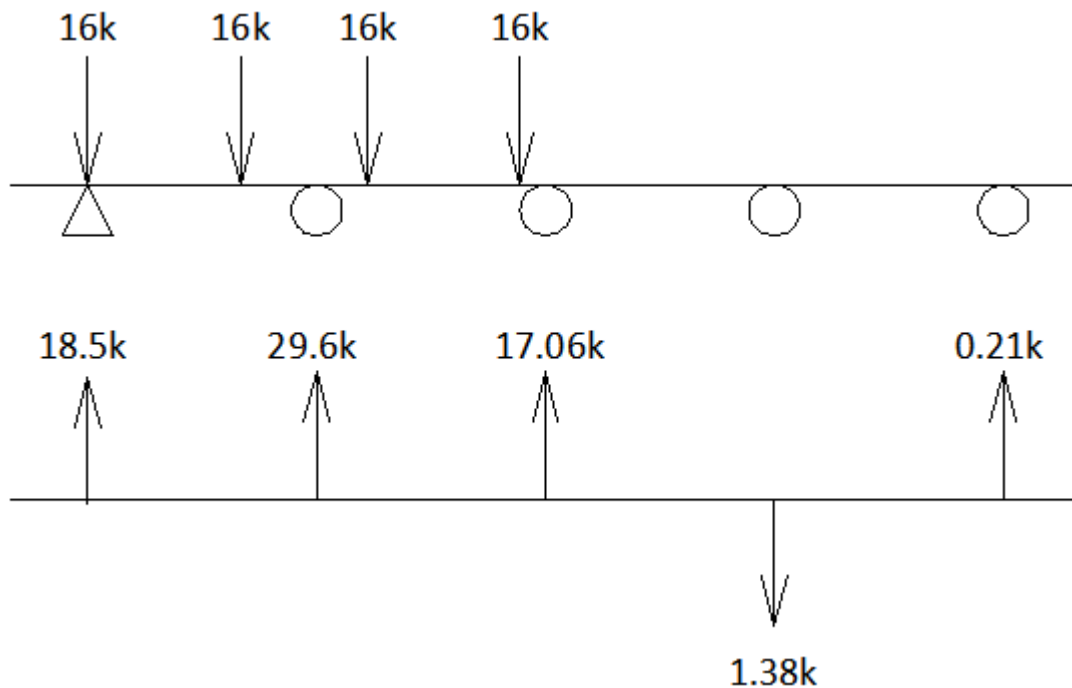

Moment caused by Case-1 is:

$$(18.5\text{kip} - 0.21\text{kip}) \cdot 18\text{ft} + (29.6\text{kip} + 1.38\text{kip}) \cdot 9\text{ft} = 608.04 \cdot \text{kip} \cdot \text{ft}$$

Case 2: Left wheel of the one of the trucks is on 2 ft right to the edge of the slab which is the closest point to the left permitted by AASHTO 3.6.1.3.

Distances of the wheels from the left side of the deck are:

First wheel 2ft

Second wheel 8ft

Third wheel 14ft

Fourth wheel 20ft

Arrangement of loading and results are:

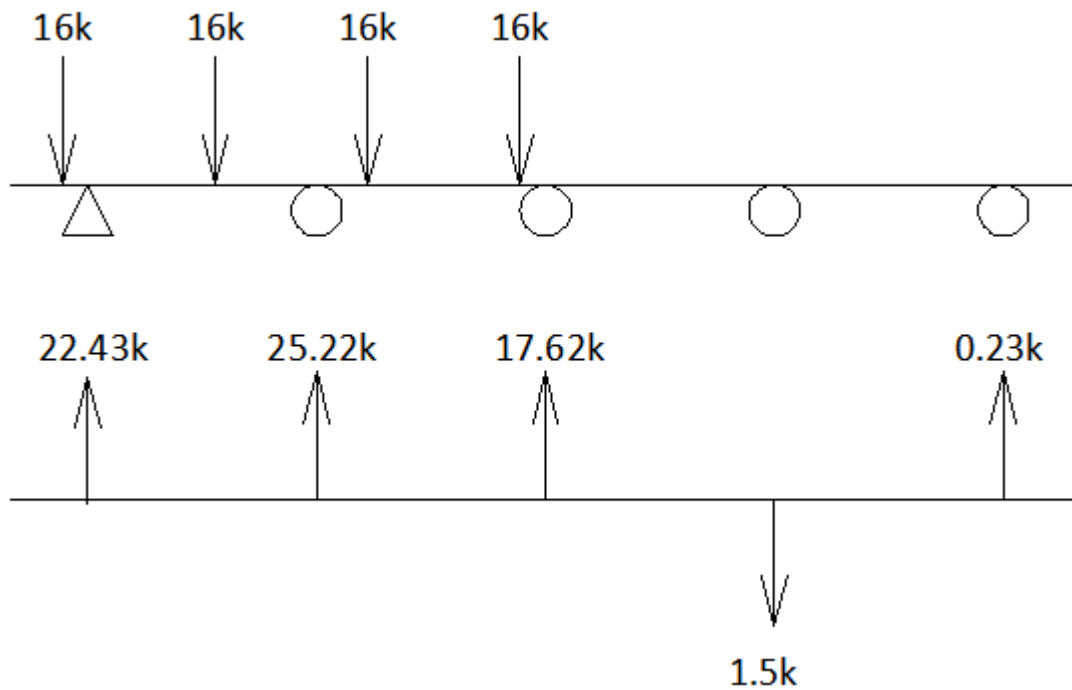

Moment caused by Case-2 is:

$$(22.43\text{kip} - 0.23\text{kip}) \cdot 18\text{ft} + (25.22\text{kip} + 1.5\text{kip}) \cdot 9\text{ft} = 640.08 \cdot \text{kip} \cdot \text{ft}$$

Therefore, Case-2 controls the design!

Total reactions on supports:

Reactions from axle over pier:

Truck:

$$R_{1TR} := 22.43\text{kip}$$

$$R_{4TR} := -1.5\text{kip}$$

$$R_{2TR} := 25.22\text{kip}$$

$$R_{5TR} := 0.23\text{kip}$$

$$R_{3TR} := 17.62\text{kip}$$

Tandem:

$$R_{1TA} := \frac{R_{1TR}}{64\text{kip}} \cdot 50\text{kip} = 17.523 \cdot \text{kip}$$

$$R_{4TA} := \frac{R_{4TR}}{64\text{kip}} \cdot 50\text{kip} = -1.172 \cdot \text{kip}$$

$$R_{2TA} := \frac{R_{2TR}}{64\text{kip}} \cdot 50\text{kip} = 19.703 \cdot \text{kip}$$

$$R_{5TA} := \frac{R_{5TR}}{64\text{kip}} \cdot 50\text{kip} = 0.18 \cdot \text{kip}$$

$$R_{3TA} := \frac{R_{3TR}}{64\text{kip}} \cdot 50\text{kip} = 13.766 \cdot \text{kip}$$

Reactions from axle on span:

Truck:

$$R_{1TRspan} := (32\text{kip} + 8\text{kip})DF_1 \cdot R_{21} = 31.68 \cdot \text{kip}$$

$$R_{2TRspan} := (32\text{kip} + 8\text{kip})DF_1 \cdot R_{22} = 23.76 \cdot \text{kip}$$

$$R_{3TRspan} := (32\text{kip} + 8\text{kip})DF_1 \cdot R_{23} = 15.84 \cdot \text{kip}$$

$$R_{4TRspan} := (32\text{kip} + 8\text{kip})DF_1 \cdot R_{24} = 7.92 \cdot \text{kip}$$

$$R_{5TRspan} := (32\text{kip} + 8\text{kip})DF_1 \cdot R_{25} = 2.198 \times 10^{-15} \cdot \text{kip}$$

Tandem:

$$R_{1TAspan} := (25\text{kip}) \cdot DF_{\text{tandem}} \cdot R_{21} = 20.2 \cdot \text{kip}$$

$$R_{2TAspan} := (25\text{kip}) \cdot DF_{\text{tandem}} \cdot R_{22} = 15.15 \cdot \text{kip}$$

$$R_{3TAspan} := (25\text{kip}) \cdot DF_{\text{tandem}} \cdot R_{23} = 10.1 \cdot \text{kip}$$

$$R_{4TAspan} := (25\text{kip}) \cdot DF_{\text{tandem}} \cdot R_{24} = 5.05 \cdot \text{kip}$$

$$R_{5TAspan} := (25\text{kip}) \cdot DF_{\text{tandem}} \cdot R_{25} = 1.402 \times 10^{-15} \cdot \text{kip}$$

Distribution of lane loading to the girders:

$$R_{1lane} := \left(0.64 \frac{\text{kip}}{\text{ft}} \cdot L \right) \cdot R_{21} = 46.08 \cdot \text{kip}$$

$$R_{2lane} := \left(0.64 \frac{\text{kip}}{\text{ft}} \cdot L \right) \cdot R_{22} = 34.56 \cdot \text{kip}$$

$$R_{3lane} := \left(0.64 \frac{\text{kip}}{\text{ft}} \cdot L \right) \cdot R_{23} = 23.04 \cdot \text{kip}$$

$$R_{4lane} := \left(0.64 \frac{\text{kip}}{\text{ft}} \cdot L \right) \cdot R_{24} = 11.52 \cdot \text{kip}$$

$$R_{5lane} := \left(0.64 \frac{\text{kip}}{\text{ft}} \cdot L \right) \cdot R_{25} = 3.197 \times 10^{-15} \cdot \text{kip}$$

Total loads:

Because of Truck:

$$R_{1TR} := R_{1TR} + R_{1TRspan} + R_{1lane} = 100.19 \cdot \text{kip}$$

$$R_{2TR} := R_{2TR} + R_{2TRspan} + R_{2lane} = 83.54 \cdot \text{kip}$$

$$R_{3TR} := R_{3TR} + R_{3TRspan} + R_{3lane} = 56.5 \cdot \text{kip}$$

$$R_{4TR} := R_{4TR} + R_{4TRspan} + R_{4lane} = 17.94 \cdot \text{kip}$$

$$R_{5TR} := R_{5TR} + R_{5TRspan} + R_{5lane} = 0.23 \cdot \text{kip}$$

Because of Tandem:

$$R_{1TA} := R_{1TA} + R_{1TAspan} + R_{1lane} = 83.803 \cdot \text{kip}$$

$$R_{2TA} := R_{2TA} + R_{2TAspan} + R_{2lane} = 69.413 \cdot \text{kip}$$

$$R_{3TA} := R_{3TA} + R_{3TAspan} + R_{3lane} = 46.906 \cdot \text{kip}$$

$$R_{4TA} := R_{4TA} + R_{4TAspan} + R_{4lane} = 15.398 \cdot \text{kip}$$

$$R_{5TA} := R_{5TA} + R_{5TAspan} + R_{5lane} = 0.18 \cdot \text{kip}$$

As can be seen easily, all loads caused by truck is higher than tandem, therefore our design forces are truck forces!

Braking Force (LRFD 3.6.4):

Braking force is applied in the longitudinal direction of the bridge.
Maximum of the following forces is taken into account and applied to the bridge.

25% of (Truck/Tandem) or 5% of (Truck/Tandem + Lane)

$$F_{0.25xtruck} := 0.25 \cdot (32\text{kip} + 32\text{kip} + 8\text{kip}) = 18 \cdot \text{kip}$$

$$F_{0.25xtandem} := 0.25 \cdot (25\text{kip} + 25\text{kip}) = 12.5 \cdot \text{kip}$$

$$F_{\max 1} := \max(F_{0.25xtruck}, F_{0.25xtandem}) = 18 \cdot \text{kip}$$

$$F_{0.05x(truck+lane)} := 0.05 \cdot \left[(32\text{kip} + 32\text{kip} + 8\text{kip}) + 0.64 \frac{\text{kip}}{\text{ft}} \cdot L \right] = 6.48 \cdot \text{kip}$$

$$F_{0.05x(tandem+lane)} := 0.05 \cdot \left[(25\text{kip} + 25\text{kip}) + 0.64 \frac{\text{kip}}{\text{ft}} \cdot L \right] = 5.38 \cdot \text{kip}$$

$$F_{\max 2} := \max(F_{0.05x(truck+lane)}, F_{0.05x(tandem+lane)}) = 6.48 \cdot \text{kip}$$

$$F_{\max_per_lane} := \max(F_{\max 1}, F_{\max 2}) = 18 \cdot \text{kip}$$

Using multiple presence factor for lanes, we can obtain total braking force required to be applied to the bridge:

MPF = 1.2 for one lane loaded

MPF = 1 for two lanes loaded

MPF = 0.85 for three

MPF = 0.65 for four and higher lanes loaded

The reason why all lanes are loaded is the probability of the bridge to be a one direction bridge in the future.

$$F_{\max_for_bridge} := \max(1.2 \cdot F_{\max_per_lane}, 2 \cdot 1 \cdot F_{\max_per_lane}, 3 \cdot 0.85 \cdot F_{\max_per_lane})$$

$$F_{\max_for_bridge} = 45.9 \cdot \text{kip}$$

$$F_{\max_per_girder} := \frac{F_{\max_for_bridge}}{N_g}$$

$$F_{\max_per_girder} = 9.18 \cdot \text{kip}$$

braking force per girder

Force due to braking force should be applied 6 ft over roadway (LRFD 3.6.4).

$$M_{\text{braking_per_girder}} := F_{\text{max_per_girder}} \cdot \left(6\text{ft} + t_{\text{deck}} + H_{\text{girder}} + \frac{H_{\text{cap}}}{2} \right)$$

$$M_{\text{braking_per_girder}} = 111.69 \cdot \text{kip} \cdot \text{ft}$$

$F_{\text{max_per_girder}}$ and $M_{\text{braking_per_girder}}$ should be applied to pier frame model at each girder location at mid height of the pier cap in the longitudinal direction.

Thermal Forces (WisDOT Bridge Manual 13.4):

Commonly, bridges which are not in earthquake regions have only one fixed pier, other piers and abutments are constructed with expansion joints. While modeling expansion piers, we assume that longitudinal force acting on those piers are dead load times coefficient of friction. Here in this example, we will assume that one pier is fixed and others have expansion joints. We also want to find the biggest force on this fixed pier. Therefore, using longitudinal force equilibrium, we will determine the largest temperature force on fixed pier. The thermal force on a single fixed pier in a bridge is the resultant of the unbalanced forces acting on the substructure units. Maximum friction coefficients are assumed for expansion bearings on one side of the bridge and minimum coefficients on the other side to produce the greatest unbalanced force on the fixed pier.

$$\mu_{\text{max}} := 0.1$$

maximum coefficient of friction

$$\mu_{\text{min}} := 0.06$$

minimum coefficient of friction

$$\Sigma DL_{\text{ext}} := (P_{\text{extDL}} + P_{\text{extWL}}) = 75.645 \cdot \text{kip}$$

dead load on abutment.

$$\Sigma DL_{\text{int}} := (P_{\text{intDL}} + P_{\text{intWL}}) = 151.29 \cdot \text{kip}$$

dead load on interior pier

$$P_{\text{temp}} := \Sigma DL_{\text{ext}} \cdot (\mu_{\text{max}} - \mu_{\text{min}}) + \Sigma DL_{\text{int}} \cdot \mu_{\text{max}} = 18.155 \cdot \text{kip}$$

to get the worst force on fixed pier

$$P_{\text{girdertemp}} := \frac{P_{\text{temp}}}{N_g} = 3.631 \cdot \text{kip}$$

thermal force on fixed pier due to one girder.

Wind Load (LRFD 3.8):

In AASHTO LRFD, design velocity of the bridge should be modified with equation LRFD 3.8.1.1-1 accordingly if the bridge height is more than 30 ft. In this example, we will assume our bridge is lower than or equal to 30 ft.

Therefore;

$$V_B := 100\text{mph}$$

for bridges or parts of bridges which are lower than 30 ft.

$$V_{DZ} := V_B$$

design velocity of bridge is equal to base design velocity for our case.

Wind Pressure On Structures, WS (LRFD 3.8.1.2):

$$L_{\text{tributary}} := L$$

tributary length of the bridge for one pier cap and set of columns attached to it (ft)

$$P_B := 0.05 \text{ksf}$$

base pressure LRFD Table 3.8.1.2.1-1 for windward direction.

$$P_D := P_B \cdot \left(\frac{V_{DZ}}{V_B} \right)^2 = 0.05 \cdot \frac{\text{kip}}{\text{ft}^2}$$

LRFD Equation 3.8.1.2.1-1 to calculate design wind pressure (ksf)

$$\text{Depth}_{\text{superstructure}} := \text{Parapet} + H_{\text{girder}} + t_{\text{deck}} = 6.417 \cdot \text{ft}$$

depth of superstructure that will be exposed to wind pressure.

$$F_{\text{transwind}} := P_D \cdot \text{Depth}_{\text{superstructure}} \cdot L_{\text{tributary}}$$

wind force on superstructure for the indicated tributary area.

$$F_{\text{transwind}} = 28.875 \cdot \text{kip}$$

$$F_{\text{transwind}} := \begin{cases} F_{\text{transwind}} & \text{if } \frac{F_{\text{transwind}}}{L} \geq 0.3 \text{klf} \\ (0.3 \text{klf} \cdot L) & \text{if } \frac{F_{\text{transwind}}}{L} < 0.3 \text{klf} \end{cases}$$

check for the minimum load per lineal foot that should be applied on bridge superstructure (LRFD 3.8.1.2.1 General)

$$F_{\text{transwind}} = 28.875 \cdot \text{kip}$$

$$F_{\text{pergirder}} := \frac{F_{\text{transwind}}}{N_g} = 5.775 \cdot \text{kip}$$

force at each girder location due to wind on superstructure in transverse direction

$$M_{\text{cap}} := F_{\text{transwind}} \cdot \left(\text{Depth}_{\text{superstructure}} + \frac{H_{\text{cap}}}{2} \right)$$

moment on pier cap due to wind load on superstructure.

$$M_{\text{cap}} = 235.813 \cdot \text{kip} \cdot \text{ft}$$

$$M_{\text{cap_pergirder}} := \frac{M_{\text{cap}}}{N_g} = 47.163 \cdot \text{kip} \cdot \text{ft}$$

moment on each girder location due to wind force on superstructure in transverse direction.

Wind Pressure On Vehicles, WL (LRFD 3.8.1.3):

Wind pressure on vehicles shall be represented by an interruptible, moving force of 0.1 klf acting normal to, and 6 ft above, the roadway and shall be transmitted to the structure.

Moreover, we need to multiply 0.1 kips per lineal foot with the tributary length of the bridge as follows:

$$F_{\text{vehicle}} := (0.1 \text{klf}) \cdot L_{\text{tributary}} = 9 \cdot \text{kip}$$

$$F_{\text{vehicle_pergirder}} := \frac{F_{\text{vehicle}}}{N_g} = 1.8 \cdot \text{kip}$$

force at each girder location in transverse direction due to wind on vehicles

$$M_{\text{capduetovehicle}} := F_{\text{vehicle}} \cdot \left(\text{Depth}_{\text{superstructure}} + \frac{H_{\text{cap}}}{2} + 6 \text{ft} \right)$$

$$M_{\text{capduetovehicle}} = 127.5 \cdot \text{kip} \cdot \text{ft}$$

moment on pier cap due to wind load on vehicle which is applied 6 ft above the roadway.

$$M_{\text{capduetovehicle_pergirder}} := \frac{M_{\text{capduetovehicle}}}{N_g}$$

$$M_{\text{capduetovehicle_pergirder}} = 25.5 \cdot \text{kip} \cdot \text{ft}$$

moment on each girder location due to wind force on vehicle in transverse direction.

Wind On Substructure, (LRFD 3.8.1.2.3):

Assumed base wind pressure pointed out in LRFD is 0.04 ksf for both directions for substructures.

For wind directions taken skewed to the substructure, this force shall be resolved into components perpendicular to the end and front elevations of the substructure.

Wind force on substructure shall be applied simultaneously with the wind force from the superstructure.

$$F_{\text{piercap}} := W_{\text{cap}} \cdot H_{\text{cap}} \cdot 0.04 \text{ksf} = 0.42 \cdot \text{kip}$$

force on piercap that will be applied at the center of the cap.

$$F_{\text{pier}} := \Phi_{\text{pier}} \cdot L_{\text{pier}} \cdot 0.04 \text{ksf} = 1.6 \cdot \text{kip}$$

wind force on one pier.

If the wind is desired to be applied with a skew angle of attack, wind pressure should be seperated to its components and applied to structure in longitudinal and transverse directions simultaneously. The components of the pressure with various angles of attack is given in LRFD Table 3.8.1.2.2-1

All inputs are in red color.

All checks are in yellow color.

Pier Cap Dimensions:

$$b := 3.5\text{ft}$$

width of the x-section

$$h := 3.5\text{ft}$$

height of the x-section

$$L := 42\text{ft}$$

length of the cap

$$\text{cover} := 2.5\text{in}$$

clear cover

$$I_g := \frac{1}{12} \cdot b \cdot h^3 = 12.505 \cdot \text{ft}^4$$

gross moment of inertia of the section

Material Properties:

Concrete:

$$f_c := 4.0 \cdot \text{ksi}$$

design strength of concrete

$$f_r := 0.37 \cdot \left(\frac{f_c}{\text{ksi}} \right)^{0.5} \text{ ksi} = 0.74 \cdot \text{ksi}$$

modulus of rupture of concrete (LRFD 5.4.2.6) to be used in minimum reinforcement check

$$\beta_1 := \min \left[0.85, 0.85 - 0.05 \cdot \left(\frac{f_c}{\text{ksi}} - 4 \right) \right] = 0.85$$

neutral axis multiplier, LRFD 5.7.2.2

Steel:

$$f_y := 60 \cdot \text{ksi}$$

yield strength of reinforcing bars

$$E_s := 29000 \cdot \text{ksi}$$

modulus of elasticity of reinforcing bars (LRFD 5.4.3.2)

$$\epsilon_y := \frac{f_y}{E_s} = 2.069 \times 10^{-3}$$

yield strain of reinforcing bars

Resistance Factors, LRFD 5.5.4.2:

$$\phi := 0.9$$

for tension controlled reinforced concrete sections

$$\phi_c := 0.75$$

for compression controlled reinforced concrete sections

Design Forces:Design forces are for transverse direction of the bridge. Please enter design moments and shear obtained from analysis under factored loads below:

$$M_{d_pos} := 1915 \cdot \text{kip} \cdot \text{ft}$$

maximum positive design moment

$$M_{d_neg} := 1187 \cdot \text{kip} \cdot \text{ft}$$

maximum negative design moment

$$V_d := 550 \cdot \text{kip}$$

maximum design shear force

Reinforcement Calculations:Positive Moment Reinforcement, (ignoring compression steel's contribution):

Please change the amount of steel below until you reach design moment:

$$N := 10$$

bar size

$$n := 11$$

number of longitudinal bars

$$n_{\text{layer}} := 2$$

number of horizontal layers of longitudinal reinforcements, it can be entered up to 4 layers for this sheet

$$s_{\text{layer}} := 3 \text{ in}$$

center to center distance between different layer reinforcements

$$\phi_{\text{long}} := \frac{N}{8} \cdot \text{in} = 1.25 \cdot \text{in}$$

diameter of longitudinal reinforcement

$$A_{\text{pos}} := n \cdot \left[\pi \cdot \left(\frac{\phi_{\text{long}}}{2} \right)^2 \right] = 13.499 \cdot \text{in}^2$$

area of positive moment reinforcement

$$N_{\text{stir}} := 5$$

rebar size for stirrup, change if not enough for shear, shear calculations are below flexure calculations

$$\phi_{\text{stir}} := \frac{N_{\text{stir}}}{8} \cdot \text{in} = 0.625 \cdot \text{in}$$

diameter of stirrups

$$s_{\text{long}} := \frac{b - 2 \cdot \text{cover} - 2 \cdot \phi_{\text{stir}} - \phi_{\text{long}}}{n - 1} = 3.45 \cdot \text{in}$$

spacing between longitudinal reinforcement (center to center)

$$d_{e1} := h - \text{cover} - \phi_{\text{stir}} - \frac{\phi_{\text{long}}}{2} = 38.25 \cdot \text{in}$$

effective depth of the first line of longitudinal reinforcement

$$d_{e2} := d_{e1} - s_{\text{layer}} = 35.25 \cdot \text{in}$$

for second layer

$$d_{e3} := d_{e2} - s_{\text{layer}} = 32.25 \cdot \text{in}$$

for third layer

$$d_{e4} := d_{e3} - s_{\text{layer}} = 29.25 \cdot \text{in}$$

for fourth layer

$$d_e := \begin{cases} d_{e1} & \text{if } n_{\text{layer}} = 1 \\ \frac{d_{e1} + d_{e2}}{2} & \text{if } n_{\text{layer}} = 2 \\ \frac{d_{e1} + d_{e2} + d_{e3}}{3} & \text{if } n_{\text{layer}} = 3 \\ \frac{d_{e1} + d_{e2} + d_{e3} + d_{e4}}{4} & \text{if } n_{\text{layer}} = 4 \end{cases} = 36.75 \cdot \text{in}$$

effective depth

$$c := \frac{A_{\text{pos}} \cdot f_y}{0.85 \cdot f_c \cdot \beta_1 \cdot b} = 6.673 \cdot \text{in}$$

neutral axis depth from the top

$$\epsilon_{s1} := 0.003 \cdot \frac{d_{e1} - c}{c} = 0.014$$

strain in tension reinforcement

Check if the section is tension controlled:

$$\text{section_is} := \begin{cases} \text{"tension controlled"} & \text{if } \epsilon_{s1} \geq 0.005 \\ \text{"compression controlled"} & \text{otherwise} \end{cases}$$

if section is compression controlled, either make it tension controlled or use $\phi_c = 0.75$ for resistance factor

$$\text{section_is} = \text{"tension controlled"}$$

$$a := \beta_1 \cdot c = 5.672 \cdot \text{in}$$

$$M_n := A_{\text{pos}} \cdot f_y \cdot \left(d_e - \frac{a}{2} \right) = 2.289 \times 10^3 \cdot \text{kip} \cdot \text{ft}$$

$$M_r := \phi \cdot M_n = 2.06 \times 10^3 \cdot \text{kip} \cdot \text{ft}$$

factored moment capacity

$$\text{moment_capacity} := \begin{cases} \text{"is enough"} & \text{if } M_{d_pos} < M_r \\ \text{"is not enough"} & \text{otherwise} \end{cases}$$

check for moment capacity

$$\text{moment_capacity} = \text{"is enough"}$$

Control of Cracking by Distribution of Reinforcement, LRFD 5.7.3.4:

$$s \leq \frac{700 \gamma_e}{\beta_s \cdot f_{ss}} - 2 \cdot d_c$$

in which:

$$\beta_s := 1 + \frac{d_c}{0.7 \cdot (h - d_c)}$$

where:

γ_e = exposure factor
 = 1 for Class 1 exposure condition
 = 0.75 for Class 2 exposure condition
 (use Class 2 if the element is exposed to water)

d_c = thickness of concrete cover from tension fiber to center of closest reinforcement (in)

f_{ss} = tensile stress in steel at the service limit state (ksi)

h = overall thickness or depth of component (in)

$$\gamma_e := 0.75$$

$$d_c := \text{cover} + \phi_{\text{stir}} + \frac{\phi_{\text{long}}}{2} = 3.75 \cdot \text{in}$$

$$\beta_s := 1 + \frac{d_c}{0.7 \cdot (h - d_c)} = 1.14$$

$$M_{\text{service}} := \frac{M_{d_pos}}{1.5} = 1.277 \times 10^3 \cdot \text{kip} \cdot \text{ft}$$

assuming that the service moment is design moment over a factor of 1.5

ignore compression steel!

$$n_{\text{modular}} := 8$$

modular ratio

$$x := 3 \text{ in}$$

initial guess for neutral axis depth

$$x := \text{root} \left[b \cdot x \cdot \frac{x}{2} - A_{\text{pos}} \cdot n_{\text{modular}} \cdot (d_e - x), x \right]$$

$$x = 11.414 \cdot \text{in}$$

$$I_{\text{cr}} := \frac{1}{3} \cdot b \cdot x^3 + A_{\text{pos}} \cdot n_{\text{modular}} \cdot (d_e - x)^2 = 9.014 \times 10^4 \cdot \text{in}^4$$

$$f_{\text{ss}} := \frac{M_{\text{service}} \cdot (d_e - x)}{I_{\text{cr}}} \cdot n_{\text{modular}} = 34.448 \cdot \text{ksi}$$

$$s_{\text{max}} := \frac{700 \gamma_e}{\beta_s \cdot \frac{f_{\text{ss}}}{\text{ksi}}} \text{in} - 2 \cdot d_c = 5.868 \cdot \text{in}$$

$$s_{\max 1} := \text{floor}\left(\frac{s_{\max}}{\text{in}}\right) \text{in} = 5 \cdot \text{in}$$

Minimum and maximum spacing of reinforcement shall also comply with the provisions of Articles 5.10.3.1 and 5.10.3.2 respectively.

Which are:

$$s_{\max 2} := \min(1.5 \cdot h, 18 \cdot \text{in})$$

$$s_{\max 2} = 18 \cdot \text{in}$$

s can not be greater than 1.5 times the thickness of the member or 18 in.

$$s_{\max} := \min(s_{\max 1}, s_{\max 2})$$

$$s_{\max} = 5 \cdot \text{in}$$

$$\text{spacing_is} := \begin{cases} \text{"ok"} & \text{if } s_{\text{long}} \leq s_{\max} \\ \text{"not ok"} & \text{otherwise} \end{cases}$$

$$\text{spacing_is} = \text{"ok"}$$

Negative Moment Reinforcement, (ignoring compression steel's contribution):

Please change the amount of steel below until you reach design moment:

$$N := 9$$

bar size

$$n := 8$$

number of longitudinal bars

$$n_{\text{layer}} := 1$$

number of horizontal layers of longitudinal reinforcements, it can be entered up to 4 layers for this sheet

$$s_{\text{layer}} := 3 \text{ in}$$

center to center distance between different layer reinforcements

$$\phi_{\text{long}} := \frac{N}{8} \cdot \text{in} = 1.125 \cdot \text{in}$$

diameter of longitudinal reinforcement

$$A_{\text{neg}} := n \cdot \left[\pi \cdot \left(\frac{\phi_{\text{long}}}{2} \right)^2 \right] = 7.952 \cdot \text{in}^2$$

area of positive moment
reinforcement

$$s_{\text{long}} := \frac{b - 2 \cdot \text{cover} - 2 \cdot \phi_{\text{stir}} - \phi_{\text{long}}}{n - 1} = 4.946 \cdot \text{in}$$

spacing between longitudinal
reinforcement (center to center)

$$d_{e1} := h - \text{cover} - \phi_{\text{stir}} - \frac{\phi_{\text{long}}}{2} = 38.313 \cdot \text{in}$$

effective depth of the first line of
longitudinal reinforcement

$$d_{e2} := d_{e1} - s_{\text{layer}} = 35.313 \cdot \text{in}$$

for second layer

$$d_{e3} := d_{e2} - s_{\text{layer}} = 32.313 \cdot \text{in}$$

for third layer

$$d_{e4} := d_{e3} - s_{\text{layer}} = 29.312 \cdot \text{in}$$

for fourth layer

$$d_e := \begin{cases} d_{e1} & \text{if } n_{\text{layer}} = 1 \\ \frac{d_{e1} + d_{e2}}{2} & \text{if } n_{\text{layer}} = 2 \\ \frac{d_{e1} + d_{e2} + d_{e3}}{3} & \text{if } n_{\text{layer}} = 3 \\ \frac{d_{e1} + d_{e2} + d_{e3} + d_{e4}}{4} & \text{if } n_{\text{layer}} = 4 \end{cases} = 38.313 \cdot \text{in}$$

effective depth

$$c := \frac{A_{\text{neg}} \cdot f_y}{0.85 \cdot f_c \cdot \beta_1 \cdot b} = 3.931 \cdot \text{in}$$

neutral axis depth from the top

$$\epsilon_{s1} := 0.003 \cdot \frac{d_{e1} - c}{c} = 0.026$$

strain in tension reinforcement

Check if the section is tension controlled:

$$\text{section_is} := \begin{cases} \text{"tension controlled"} & \text{if } \epsilon_{s1} \geq 0.005 \\ \text{"compression controlled"} & \text{otherwise} \end{cases}$$

if section is compression controlled,
either make it tension controlled or
use $\phi_c = 0.75$ for resistance factor

$$\text{section_is} = \text{"tension controlled"}$$

$$a := \beta_1 \cdot c = 3.341 \cdot \text{in}$$

$$M_n := A_{\text{neg}} \cdot f_y \cdot \left(d_e - \frac{a}{2} \right) = 1.457 \times 10^3 \cdot \text{kip} \cdot \text{ft}$$

$$M_r := \phi \cdot M_n = 1.311 \times 10^3 \cdot \text{kip} \cdot \text{ft}$$

factored moment capacity

$$\text{moment_capacity} := \begin{cases} \text{"is enough"} & \text{if } M_{d_neg} < M_r \\ \text{"is not enough"} & \text{otherwise} \end{cases}$$

check for moment capacity

$$\text{moment_capacity} = \text{"is enough"}$$

Control of Cracking by Distribution of Reinforcement, LRFD 5.7.3.4:

$$s \leq \frac{700 \gamma_e}{\beta_s \cdot f_{ss}} - 2 \cdot d_c$$

in which:

$$\beta_s := 1 + \frac{d_c}{0.7 \cdot (h - d_c)}$$

where:

γ_e = exposure factor
 = 1 for Class 1 exposure condition
 = 0.75 for Class 2 exposure condition
 (use Class 2 if the element is exposed to water)

d_c = thickness of concrete cover from tension fiber to center of closest reinforcement (in)

f_{ss} = tensile stress in steel at the service limit state (ksi)

h = overall thickness or depth of component (in)

$$\gamma_e := 0.75$$

$$d_c := \text{cover} + \phi_{\text{stir}} + \frac{\phi_{\text{long}}}{2} = 3.688 \cdot \text{in}$$

$$\beta_s := 1 + \frac{d_c}{0.7 \cdot (h - d_c)} = 1.137$$

$$M_{\text{service}} := \frac{M_{d_neg}}{1.5} = 791.333 \cdot \text{kip} \cdot \text{ft}$$

assuming that the service moment is design moment over a factor of 1.5

ignore compression steel!

$$x := 3 \text{ in}$$

initial guess for neutral axis depth

$$x := \text{root} \left[b \cdot x \cdot \frac{x}{2} - A_{\text{neg}} \cdot n_{\text{modular}} \cdot (d_e - x), x \right]$$

$$x = 9.365 \cdot \text{in}$$

$$I_{\text{cr}} := \frac{1}{3} \cdot b \cdot x^3 + A_{\text{neg}} \cdot n_{\text{modular}} \cdot (d_e - x)^2 = 6.481 \times 10^4 \cdot \text{in}^4$$

$$f_{\text{ss}} := \frac{M_{\text{service}} \cdot (d_e - x)}{I_{\text{cr}}} \cdot n_{\text{modular}} = 33.933 \cdot \text{ksi}$$

$$s_{\text{max}} := \frac{700 \gamma_e}{\beta_s \cdot \frac{f_{\text{ss}}}{\text{ksi}}} \text{in} - 2 \cdot d_c = 6.226 \cdot \text{in}$$

$$s_{\text{max}1} := \text{floor} \left(\frac{s_{\text{max}}}{\text{in}} \right) \text{in} = 6 \cdot \text{in}$$

Minimum and maximum spacing of reinforcement shall also comply with the provisions of Articles 5.10.3.1 and 5.10.3.2 respectively.

Which are:

$$s_{\max 2} := \min(1.5 \cdot h, 18 \cdot \text{in})$$

$$s_{\max 2} = 18 \cdot \text{in}$$

s can not be greater than 1.5 times the thickness of the member or 18 in.

$$s_{\max} := \min(s_{\max 1}, s_{\max 2})$$

$$s_{\max} = 6 \cdot \text{in}$$

$$\text{spacing_is} := \begin{cases} \text{"ok"} & \text{if } s_{\text{long}} \leq s_{\max} \\ \text{"not ok"} & \text{otherwise} \end{cases}$$

$$\text{spacing_is} = \text{"ok"}$$

Shear Check, LRFD 5.8.3:

We need transverse reinforcement if:

$$V_u > 0.5 \cdot \phi \cdot V_c$$

where:

V_u = factored shear force

V_c = nominal shear resistance of the concrete

ϕ = resistance factor specified in 5.5.4.2

Shear strength of concrete, LRFD 5.8.3.3:

$$V_c = 0.0316 \cdot \beta \cdot (f_c)^{0.5} \cdot b_v \cdot d_v$$

$$b_v := b = 42 \cdot \text{in}$$

effective web width, LRFD 5.8.2.9

$$d_v := \max(0.72 \cdot h, 0.9 \cdot d_e) = 34.481 \cdot \text{in}$$

effective depth, LRFD 5.8.2.9

Since we will put at least minimum transverse reinforcement, we can use $\beta = 2$, LRFD 5.8.3.4.1

$$\beta := 2$$

$$V_c := \left(0.0316 \cdot \beta \cdot \sqrt{\frac{f_c}{\text{ksi}}} \cdot \frac{b_v}{\text{in}} \cdot \frac{d_v}{\text{in}} \right) \cdot \text{kip} = 183.054 \cdot \text{kip}$$

Now check if we need transverse reinforcement:

$$\text{transverse_reinforcement} := \begin{cases} \text{"is not needed"} & \text{if } V_d \leq 0.5 \cdot \phi \cdot V_c \\ \text{"is needed"} & \text{otherwise} \end{cases}$$

$$\text{transverse_reinforcement} = \text{"is needed"}$$

We will put minimum amount of transverse reinforcement and check the strength, LRFD 5.8.2.5:

Shear stress on concrete, LRFD 5.8.2.9:

$$v_u := \frac{V_d}{\phi \cdot b_v \cdot d_v} = 0.422 \cdot \text{ksi}$$

Maximum spacing of transverse reinforcement, LRFD 5.8.2.7:

$$s_{\max} := \begin{cases} \min(0.8 \cdot d_v, 24 \text{ in}) & \text{if } v_u < 0.125 \cdot f_c \\ \min(0.4 \cdot d_v, 12 \text{ in}) & \text{if } v_u \geq 0.125 \cdot f_c \end{cases} = 24 \cdot \text{in}$$

$$s_{\max} := \text{floor}\left(\frac{s_{\max}}{\text{in}}\right) \text{ in} = 23 \cdot \text{in}$$

Please enter the desired transverse reinforcement number and spacing below:

$$s := 5 \text{ in}$$

should be lesser than the maximum value that is found above

$$n_{\text{leg}} := 4$$

number of stirrup legs put in one cross section

$$A_v := n_{\text{leg}} \cdot \pi \cdot \left(\frac{N_{\text{stir}}}{8} \text{ in} \cdot \frac{1}{2} \right)^2 = 1.227 \cdot \text{in}^2$$

$$A_{v_min} := 0.0316 \cdot \sqrt{\frac{f_c}{\text{ksi}}} \cdot \frac{b_v \cdot s}{\frac{f_y}{\text{ksi}}} = 0.221 \cdot \text{in}^2$$

$$\text{transverse_reinforcement} := \begin{cases} \text{"is enough for minimum amount"} & \text{if } \frac{A_v}{A_{v_min}} \geq 1 \\ \text{"is not enough for minimum amount"} & \text{otherwise} \end{cases}$$

$$\text{transverse_reinforcement} = \text{"is enough for minimum amount"}$$

Strength contribution of transverse reinforcement, LRFD 5.8.3.3:

Since the transverse reinforcement is inclined with 90 degrees to longitudinal reinforcement, equation reduces to:

$$V_s := \frac{A_v \cdot f_y \cdot d_v \cdot \cot(\theta)}{s}$$

where:

θ = angle of inclination of diagonal compressive stresses as in LRFD 5.8.3.4

Since we have at least minimum transverse reinforcement, we can use $\theta = 45$ degree

$$\theta := 45\text{deg}$$

$$V_s := \frac{A_v \cdot f_y \cdot d_v \cdot \cot(\theta)}{s} = 507.778 \cdot \text{kip}$$

$$V_n := \min(V_c + V_s, 0.25 \cdot f_c \cdot b_v \cdot d_v)$$

nominal shear strength of the section, LRFD 5.8.3.3

$$V_n = 690.832 \cdot \text{kip}$$

$$\text{shear_strength} := \begin{cases} \text{"is enough"} & \text{if } V_d \leq \phi \cdot V_n \\ \text{"is not enough"} & \text{otherwise} \end{cases}$$

$$\text{shear_strength} = \text{"is enough"}$$

Shrinkage and Temperature Reinforcement, LRFD 5.10.8:

The area of S&T reinforcement per foot, on each face and in each direction shall not be less than:

$$A_{ST} := \left[\frac{1.3 \cdot \frac{b}{\text{in}} \cdot \frac{h}{\text{in}}}{2 \cdot \frac{(b+h)}{\text{in}} \cdot \frac{f_y}{\text{ksi}}} \right] \frac{\text{in}^2}{\text{ft}} = 0.228 \cdot \frac{\text{in}^2}{\text{ft}}$$

Furthermore, A_s should satisfy following conditions:

$$A_{ST} := \begin{cases} 0.11 \frac{\text{in}^2}{\text{ft}} & \text{if } A_{ST} \leq 0.11 \frac{\text{in}^2}{\text{ft}} = 0.228 \cdot \frac{\text{in}^2}{\text{ft}} \\ 0.6 \frac{\text{in}^2}{\text{ft}} & \text{if } A_{ST} \geq 0.6 \frac{\text{in}^2}{\text{ft}} \\ A_{ST} & \text{otherwise} \end{cases} \quad \text{defines the limits for reinforcement}$$

$$A_{ST} := (2 \cdot b + 2 \cdot h) \cdot A_{ST} = 3.185 \cdot \text{in}^2 \quad \text{total S\&T reinforcement required for the cross section}$$

Now check if the provided negative and positive reinforcement is enough for S&T reinforcement:

$$\text{check} := \begin{cases} \text{"ok"} & \text{if } (A_{\text{neg}} + A_{\text{pos}}) \geq A_{ST} \\ \text{"add reinforcement"} & \text{otherwise} \end{cases}$$

$$\text{check} = \text{"ok"}$$

Maximum spacing can not exceed 3 times the wall thickness or 12in:

$$s_{\max 1} := \min(3 \cdot b, 12\text{in}) = 12 \cdot \text{in}$$

New Design Examples Post-tensioned Connection for Bent Caps

Design Constants:

$f_c := 8\text{ksi}$	concrete ultimate strength
$f_{ci} := 6.2\text{ksi}$	concrete initial strength
$f_{pu} := 270\text{ksi}$	ultimate strand stress
loss := 30ksi	assumed loss
$E_{strand} := 28500\text{ksi}$	
$A_s := 0.153\text{in}^2$	area of one strand (0.5" diameter)

Section Properties:

$h := 3.5\text{ft}$	$b := 3.5\text{ft}$	
$A := h \cdot b = 1.764 \times 10^3 \cdot \text{in}^2$	$I := \frac{1}{12} \cdot b \cdot h^3 = 2.593 \times 10^5 \cdot \text{in}^4$	
$c_b := \frac{-h}{2} = -21 \cdot \text{in}$	$c_t := \frac{h}{2} = 21 \cdot \text{in}$	
$z_b := \frac{I}{c_b} = -1.235 \times 10^4 \cdot \text{in}^3$	$z_t := \frac{I}{c_t} = 1.235 \times 10^4 \cdot \text{in}^3$	
$e := \frac{h}{2} - 2.5\text{in} - \frac{3.31\text{in}}{2} = 16.845 \cdot \text{in}$		strand location at the middle support with 2.5" clear cover and 3.31" diameter duct which has a capacity of 12 strands

Post tensioning duct information from:

<http://www.dsiamerica.com/products/post-tensioning/strand-post-tensioning-system/installation/ducts.html>

$M_{max} := -1187\text{kip}\cdot\text{ft}$	maximum moment negative moment in the cap
$f_{tens} := \frac{M_{max}}{z_t} = -1.154 \cdot \text{ksi}$	maximum tension stress at the top extreme fiber due to maximum negative moment

ACI Allowable Concrete Stresses

Initial

:

$$f_{c_i} := 0.6 \cdot f_{ci} = 3.72 \cdot \text{ksi}$$

$$f_{ti} := -3 \sqrt{\frac{f_{ci}}{\text{psi}}} \text{ psi} = -0.236 \cdot \text{ksi}$$

Service:

$$f_{cs} := 0.6 \cdot f_c = 4.8 \cdot \text{ksi}$$

$$f_{ts} := -7.5 \cdot \sqrt{\frac{f_c}{\text{psi}}} \text{ psi} = -0.671 \cdot \text{ksi}$$

$$f_{ts} := -0.6 \text{ ksi}$$

reducing the tensile stress of concrete a little bit to be on the safe side

$$T_e := - \left[\frac{f_{tens} - f_{ts}}{\left(\frac{1}{A} + \frac{e}{z_t} \right)} \right] = 286.651 \cdot \text{kip}$$

required minimum effective force after 75 years to get the limiting tensile stress at the top fiber

$$T_{e_req} := h \cdot b \cdot 0.125 \text{ ksi} = 220.5 \cdot \text{kip}$$

minimum limit set by ACI

$$T_e := \max(T_e, T_{e_req}) = 286.651 \cdot \text{kip}$$

$$f_{\text{aftertransfer}} := 0.74 \cdot f_{pu} = 199.8 \cdot \text{ksi}$$

$$\Delta f_{\text{jack}} := \frac{0.25 \text{ in}}{42 \text{ ft}} \cdot E_{\text{strand}} = 14.137 \cdot \text{ksi}$$

loss due to slip of anchorage (assuming a 1/4in slip)

$$f_{\text{jacking}} := f_{\text{aftertransfer}} + \Delta f_{\text{jack}} = 213.937 \cdot \text{ksi}$$

$$\text{jacking_stress} := \begin{cases} \text{"is OK"} & \text{if } f_{\text{jacking}} \leq 0.8 \cdot f_{\text{pu}} \\ \text{"is not OK"} & \text{otherwise} \end{cases}$$

$$\text{jacking_stress} = \text{"is OK"}$$

$$f_{\text{eff}} := f_{\text{aftertransfer}} - \text{loss} = 169.8 \cdot \text{ksi}$$

effective stress after 75 years

$$\text{ratio} := \frac{f_{\text{aftertransfer}}}{f_{\text{eff}}} = 1.177$$

$$T_0 := T_e \cdot \text{ratio} = 337.296 \cdot \text{kip}$$

initial prestress force without loss

$$n := \frac{\frac{T_e}{f_{\text{eff}}}}{A_s} = 11.034$$

number of strands

Therefore, 11 strands are required! The cross sectional drawing can be seen below.

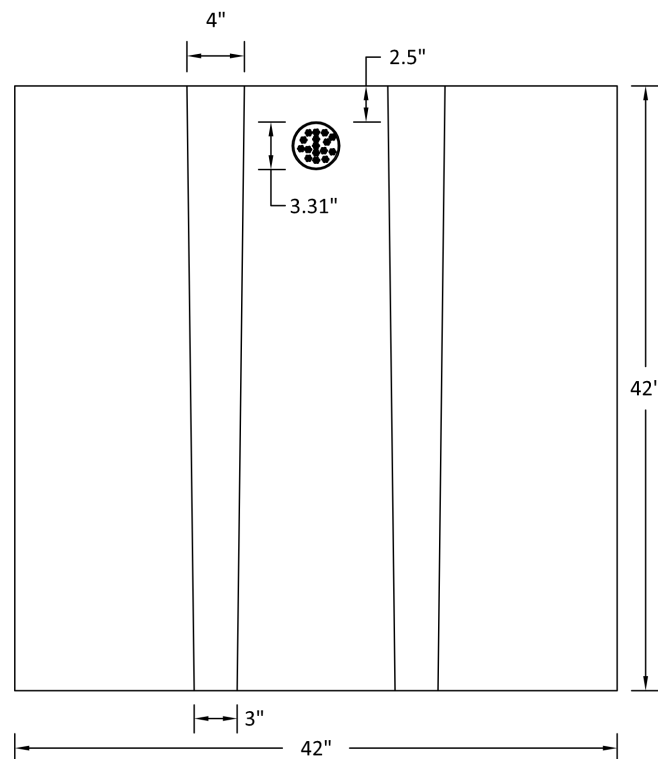

New Design Examples

Spliced Reinforcement Connection for Bent Caps

AASHTO 5.11.5.3.1 Lap Splices in Tension

Find tension development length AASHTO 5.11.2:

$N_o := 9$	bar number, should be less than #11 bar restricted by AASHTO 5.11.5.2.1
$n := 9$	number of bars
$\phi := \frac{N_o}{8} \text{ in} = 1.125 \cdot \text{in}$	diameter of the bars
$\phi_{\text{stir}} := 0.625 \text{ in}$	diameter of stirrups
$m := 4 \text{ in}$	width of the block outs (grouted pockets) for pier reinforcement
$b := 3.5 \text{ ft}$	width of bent cap
$\text{cover} := 2.5 \text{ in}$	clear cover for bent cap
$f_c := 4 \text{ ksi}$	concrete strength at 28 days
$f_y := 60 \text{ ksi}$	steel yield strength
$d_b := \frac{N_o}{8} \text{ in}$	diameter of bar
$A_b := \frac{\pi \cdot d_b^2}{4} = 0.994 \cdot \text{in}^2$	area of bar
$A_{s_required} := 7.167 \text{ in}^2$	required amount of reinforcement area
$A_{s_provided} := n \cdot A_b = 8.946 \cdot \text{in}^2$	provided reinforcement area
$\%A_{s_spliced} := 100$	percent of A_s spliced

Check to see if there is enough space between two reinforcements from the drawing below:

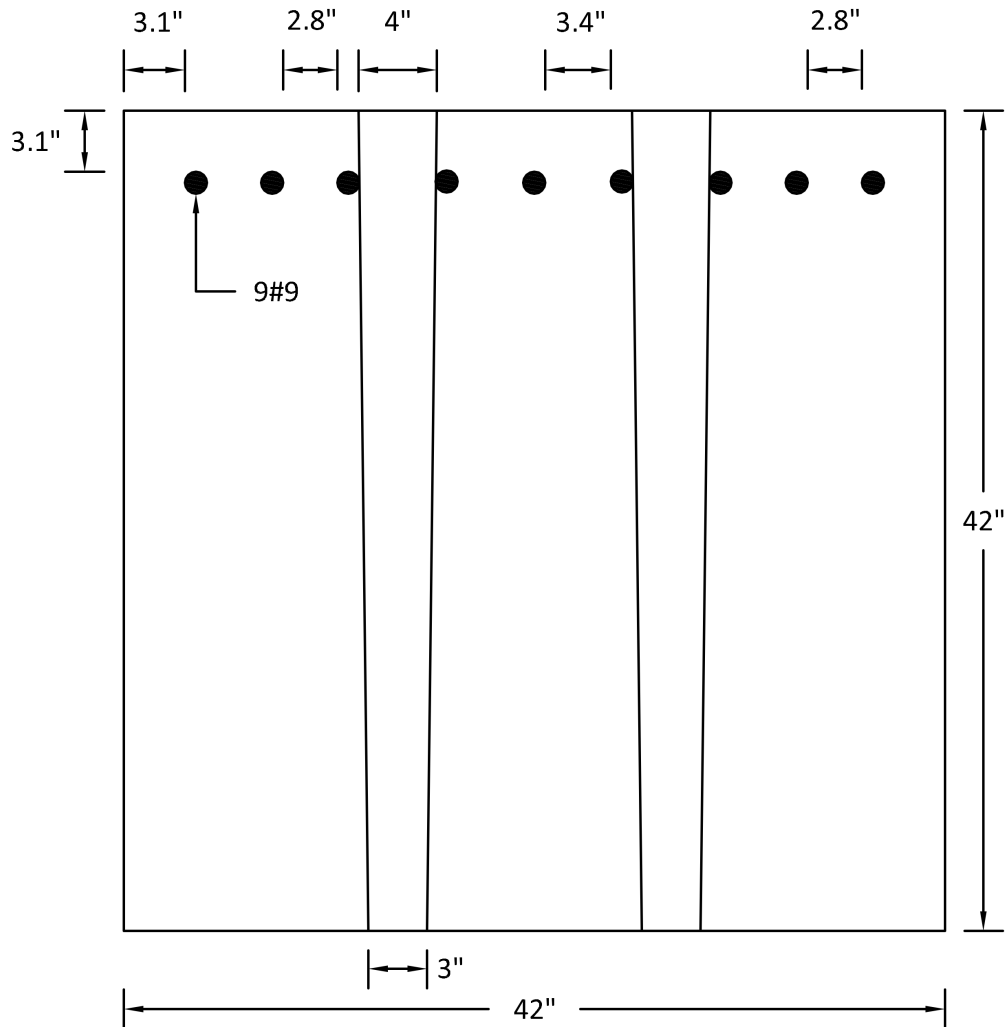

Therefore, there is enough space between two reinforcements for splicing!

$$l_{db} := \max \left[\left(\frac{1.25 \cdot \frac{A_b \cdot f_y}{\text{in}^2 \cdot \text{ksi}}}{\sqrt{\frac{f_c}{\text{ksi}}}} \right) \text{in}, 0.4d_b \cdot \frac{f_y}{\text{ksi}} \right] = 37.276 \cdot \text{in}$$

basic tension development length
for bars equal or lesser than #11
AASHTO 5.11.2.1.1

$$l_{db} := \max(l_{db}, 12\text{in}) = 37.276 \cdot \text{in}$$

basic tension development length
can not be less than 12in

Modification factors for basic development length:

Condition₁: For top horizontal or nearly horizontal reinforcement, so placed that more than 12in of fresh concrete is cast below the reinforcement

Condition₁ := "no"

$$A_1 := \begin{cases} 1.4 & \text{if Condition}_1 = \text{"yes"} \\ 1 & \text{if Condition}_1 = \text{"no"} \end{cases}$$

Condition₂: For lightweight aggregate concrete where f_{ct} (ksi) is specified.

Condition₂ := "no"

f_{ct} := 3ksi

$$A_2 := \begin{cases} \max \left(\frac{0.22 \sqrt{\frac{f_c}{\text{ksi}}}}{\frac{f_{ct}}{\text{ksi}}}, 1 \right) & \text{if Condition}_2 = \text{"yes"} \\ 1 & \text{if Condition}_2 = \text{"no"} \end{cases}$$

Condition₃: For all-lightweight concrete where f_{ct} is not specified.

Condition₃ := "no"

$$A_3 := \begin{cases} 1.3 & \text{if Condition}_3 = \text{"yes"} \\ 1 & \text{if Condition}_3 = \text{"no"} \end{cases}$$

Condition₄: For sand-lightweight concrete where f_{ct} is not specified.

Condition₄ := "no"

$$A_4 := \begin{cases} 1.2 & \text{if Condition}_4 = \text{"yes"} \\ 1 & \text{if Condition}_4 = \text{"no"} \end{cases}$$

Condition₅: For epoxy coated bars with cover less than $3d_b$ or with clear spacing between bars less than $6d_b$.

Condition₅ := "no"

$$A_5 := \begin{cases} 1.5 & \text{if Condition}_5 = \text{"yes"} \\ 1 & \text{if Condition}_5 = \text{"no"} \end{cases}$$

Condition₆: For epoxy coated bars not covered above.

Condition₆ := "no"

$$A_6 := \begin{cases} 1.2 & \text{if Condition}_6 = \text{"yes"} \\ 1 & \text{if Condition}_6 = \text{"no"} \end{cases}$$

Condition₇: Reinforcement being developed in the length under consideration is spaced laterally not less than 6in center to center, with not less than 3in clear cover measured in the direction of the spacing.

Condition₇ := "no"

$$A_7 := \begin{cases} 0.8 & \text{if Condition}_7 = \text{"yes"} \\ 1 & \text{if Condition}_7 = \text{"no"} \end{cases}$$

$$A_8 := \frac{A_{s_required}}{A_{s_provided}}$$

Condition₉: Reinforcement is enclosed within a spiral composed of bars of not less than 0.25in in diameter and spaced at not more than a 4in pitch.

Condition₉ := "no"

$$A_9 := \begin{cases} 0.75 & \text{if Condition}_9 = \text{"yes"} \\ 1 & \text{if Condition}_9 = \text{"no"} \end{cases}$$

$$l_d := \begin{cases} l_{db} \cdot 1.7 \cdot A_2 \cdot A_3 \cdot A_4 \cdot A_7 \cdot A_8 \cdot A_9 & \text{if } A_1 \cdot A_5 \geq 1.7 \vee A_1 \cdot A_6 \geq 1.7 \\ l_{db} \cdot A_1 \cdot A_2 \cdot A_3 \cdot A_4 \cdot A_5 \cdot A_6 \cdot A_7 \cdot A_8 \cdot A_9 & \text{otherwise} \end{cases}$$

$$l_d = 29.862 \cdot \text{in}$$

tension development length after factors applied

$$\text{splice} := \begin{cases} \text{if } \frac{A_{s_provided}}{A_{s_required}} \geq 2 & \text{splice condition} \\ \quad \begin{cases} \text{"Class A"} & \text{if } \%A_{s_spliced} = 50 \vee 75 \\ \text{"Class B"} & \text{if } \%A_{s_spliced} = 100 \end{cases} \\ \text{if } \frac{A_{s_provided}}{A_{s_required}} < 2 & \\ \quad \begin{cases} \text{"Class B"} & \text{if } \%A_{s_spliced} = 50 \\ \text{"Class C"} & \text{if } \%A_{s_spliced} = 75 \vee 100 \end{cases} \end{cases}$$

$$l_{splice} := \begin{cases} l_d & \text{if splice = "Class A"} \\ 1.3l_d & \text{if splice = "Class B"} \\ 1.7l_d & \text{if splice = "Class C"} \end{cases} \quad \text{splice length}$$

$$l_{splice} := \max(l_{splice}, 12\text{in}) = 50.766 \cdot \text{in} \quad \text{splice length can not be less than 12 in}$$

Using smaller diameter but more reinforcement bars will decrease the splice length!

New Design Examples

Welded Steel Plate Connection for Bent Caps

The connection between two steel plates will be welded with complete penetration groove welding. AASHTO LRFD section 6.13.3.2.2a states that "The factored resistance of complete penetration groove welded connections subjected to tension or compression normal to the effective area or parallel to the axis of the weld shall be taken as the factored resistance of the base metal."

As understood from the above statement, strength of the steel plate governs the design of the connection.

$b := 3.5\text{ft}$	width of pier cap
$h := 3.5\text{ft}$	depth of pier cap
$f_c := 4\text{ksi}$	concrete strength
$\beta_1 := \max\left[0.85 - 0.05 \cdot \frac{(f_c - 4\text{ksi})}{\text{ksi}}, 0.65\right] = 0.85$	neutral axis multiplier, (LRFD 5.7.2.2)
$f_y := 60\text{ksi}$	yield strength of steel plate
$E_s := 29000\text{ksi}$	modulus of elasticity of steel LRFD 5.4.3.2
$M_{\max} := 1187\text{kip}\cdot\text{ft}$	maximum negative moment at the location
$m := 4\text{in}$	width of the block outs (grouted pockets) for pier reinforcement
$t := 0.25\text{in}$	thickness of the steel plate
Ignoring the contribution from bottom reinforcement:	
$x := 1\text{in}$	initial guess for neutral axis depth
$x := \text{root}\left[0.85f_c \cdot b \cdot \beta_1 \cdot x - (b - 2m) \cdot t \cdot f_y, x\right]$	
$x = 4.202\cdot\text{in}$	neutral axis depth

Check if the section is tension controlled:

$$\text{section_is} := \begin{cases} \text{"tension controlled"} & \text{if } 0.003 \cdot \frac{\left(b - \frac{t}{2} - x\right)}{x} \geq 0.005 \\ \text{"compression controlled"} & \text{otherwise} \end{cases}$$

section_is = "tension controlled"

Therefore, the strength reduction factor is 0.9

$$M_n := 0.9 \cdot f_y \cdot (b - 2m) \cdot t \cdot \left(b - \frac{t}{2} - \frac{\beta_1 \cdot x}{2} \right) = 1.533 \times 10^3 \cdot \text{kip} \cdot \text{ft}$$

Even 0.25" thick steel plate is enough to resist the maximum moment at the connection region.

The strength of the weld between tension reinforcement and steel plate is not checked here because the length of the reinforcement that will be welded throughout the steel plate is thought to be enough to transfer the force from plate to reinforcements.

The fatigue of the reinforcement welding is not checked in this design example either.

Preliminary Abutment Design Example: This example studies an abutment wall module of 10 ft high (H) and 38 in thick (t) , supported by two steel HP 12x53 piles. The pile spacing is 8 ft. The design strength of concrete is 3.5ksi and the reinforcement bars have 60ksi yield strength.

Procedure	Calculations
<p>A. Under Lateral Load (Earth Pressure)</p> <p>A.1. Calculate the reactions: (AASHTO, LRFD Section 3.11.5)</p> <p>A vertical 1 ft wide strip is under Lateral Earth Pressure (linearly distributed along the height) + Live Load Surcharge (uniformly distributed along the height)</p> <p>Factored resultant shear:</p> $V = \gamma_{lateral\ earth} \times \frac{1}{2} \times \gamma_{eq} \times H^2 + \gamma_{live\ load\ surcharge} \times k_a \times \gamma_{soil} \times h_{eq} \times H$ <p>where, Load factor for lateral earth pressure (when coefficient of active lateral earth pressure is used) is $\gamma_{lateral\ earth} = 1.5$ Equivalent unit weight of backfill is $\gamma_{eq} = 0.035 \frac{kip}{ft^3}$ Load factor for live load surcharge is $\gamma_{live\ load\ surcharge} = 1.75$ Equivalent height of soil for live load surcharge (for H = 10 ft) is $h_{eq} = 3\ ft$ Coefficient of active lateral earth pressure is $k_a = 0.33$ Unit weight of soil is $\gamma_{soil} = 0.120 \frac{kip}{ft^3}$</p> <p>Factored moment at the base caused by this shear:</p> $M = \frac{H}{3} \times \left[\gamma_{lateral\ earth} \times \frac{1}{2} \times \gamma_{eq} \times H^2 \right] + \frac{H}{2} \times \left[\gamma_{live\ load\ surcharge} \times k_a \times \gamma_{soil} \times h_{eq} \times H \right]$	$V = (1.5) \times \frac{1}{2} \times \left(0.035 \frac{kip}{ft^3} \right) \times (10\ ft)^2 + (1.75) \times (0.33) \times \left(0.120 \frac{kip}{ft^3} \right) \times 3\ ft \times (10\ ft)$ $V = 2.63 \frac{kip}{ft} + 2.08 \frac{kip}{ft} = 4.71 \frac{kip}{ft}$ $M = \frac{(10\ ft)}{3} \times \left(2.63 \frac{kip}{ft} \right) + \frac{(10\ ft)}{2} \times \left(2.08 \frac{kip}{ft} \right)$ $M = 8.75 \frac{kip \times ft}{ft} + 10.4 \frac{kip \times ft}{ft} = 19.1 \frac{kip \times ft}{ft}$

This is a thick wall and the minimum reinforcing requirements may control. AASHTO requires that the moment capacity be at least 1.2 x cracking moment or 1.33 x the actual moment induced by the loading, whichever is smaller.

Design Moment:

$$M_d > \min [(1.2 \times M_{cracking}); (1.33 \times M)]$$

Where $M_{cracking} = S_c \times f_r$

A.2 Back-face Vertical Reinforcement Calculations

(AASHTO, LRFD Section 5.7.3)

Since moment is small and section thickness is large, try capacity with #4 bars spaced at 12 inches.

Neutral axis depth:

$$c = \frac{A \times f_y}{0.85 \times f_c \times \beta_1 \times s}$$

Effective depth:

$$d = t - cover - \frac{\Phi_{bar}}{2}$$

Tension steel strain:

(check tension steel strain to determine the capacity reduction factor Φ , if strain is greater than 0.005 then Φ is taken as 0.90)

$$\varepsilon = \varepsilon_c \times \frac{d - c}{c}$$

Resisting moment:

$$M_r = \Phi \times \frac{A}{s} \times f_y \times \left(d - \frac{c \times \beta_1}{2} \right)$$

where $\Phi = 0.9$ for flexure

$$M_{cracking} = 166.6 \frac{\text{kip} \times \text{ft}}{\text{ft}}$$

$$1.33 \times M = 25.5 \frac{\text{kip} \times \text{ft}}{\text{ft}}$$

$$M_d = 25.5 \frac{\text{kip} \times \text{ft}}{\text{ft}}$$

Try: # 4 bars @ 12 in
Clear cover: 2 in

$$\frac{A}{s} = 0.016 \frac{\text{in}^2}{\text{in}}$$

$$c = \frac{\left(0.016 \frac{\text{in}^2}{\text{in}} \right) \times (60 \text{ ksi})}{0.85 \times (3.5 \text{ ksi}) \times (0.85)}$$

$$c = 0.4 \text{ in}$$

$$d = 38 \text{ in} - 2 \text{ in} - \frac{0.5 \text{ in}}{2}$$

$$d = 35.8 \text{ in}$$

$$\varepsilon = 0.003 \times \frac{35.8 \text{ in} - 0.4}{0.4}$$

$$\varepsilon = 0.27 > 0.005$$

$$M_r = (0.9) \times \left(0.016 \frac{\text{in}^2}{\text{in}} \right) \times (60 \text{ ksi}) \times \left(35.8 \text{ in} - \frac{0.4 \text{ in} \times 0.85}{2} \right)$$

$$M_r = 31.4 \frac{\text{kip} \times \text{ft}}{\text{ft}} > M_d = 25.5 \frac{\text{kip} \times \text{ft}}{\text{ft}}$$

B. Shrinkage and Temperature Reinforcement

(AASHTO, LRFD Section 5.10.8)

The area of reinforcement that should be equally distributed to both faces in each direction

$$A_{s\&t} = 0.11 \times \frac{A_g}{f_y} < 0.0015 \times A_g$$

where A_g is the gross area of the section

$$A_{s\&t} = 0.11 \times \frac{(38 \text{ in}) \times \frac{(12 \text{ in})}{1 \text{ ft}}}{60 \text{ ksi}} = 0.84 \frac{\text{in}^2}{\text{ft}}$$

$$< 0.0015 \times (38 \text{ in}) \times \frac{(12 \text{ in})}{1 \text{ ft}}$$

$$= 0.68 \frac{\text{in}^2}{\text{ft}}$$

$$A_{s\&t} = 0.68 \frac{\text{in}^2}{\text{ft}}$$

$$\frac{A_{s\&t}}{2} = 0.34 \frac{\text{in}^2}{\text{ft}}$$

for each face

#4 bars @ 6in has $\frac{A}{s} = 0.39 \frac{\text{in}^2}{\text{ft}}$
in each direction and on both faces

C. Under Vertical Load

(AASHTO, LRFD Section 5.6.3)

Since the pile spacing is relatively small compared to the section depth, the beam is considered to be a deep beam and will be analyzed by strut and tie modeling.

C.1. Forming the Truss:

Several trusses are created to observe all possible load paths. The reactions are found assuming a loading forcing the piles to carry the level of load that an average pile is driven to. (~100 kips) The piles are assumed to transfer all of their reaction force in bearing at the pile end. As a conservative design – a single reaction from a girder is assumed to be applied midway between the piles.

Truss alternatives:

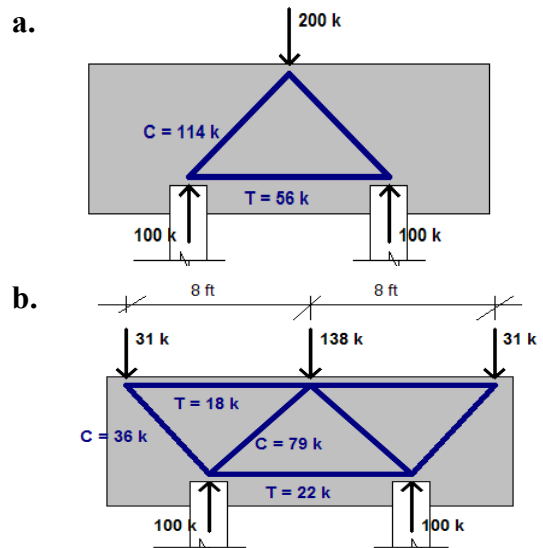

The truss which gives the most conservative compression and tension reactions:

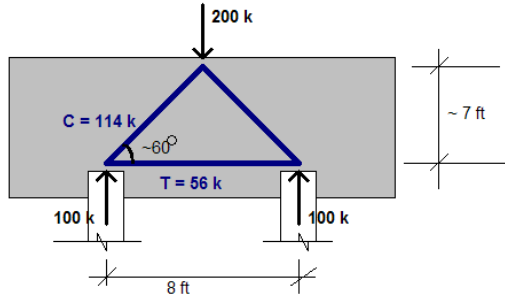

This truss has tension at the bottom of the abutment and diagonal compression members. In addition, having a truss with tension at the top cord is also a possibility such as Truss b. Therefore the same tension tie reinforcement calculated for the bottom will also be used at the top.

$$\tan \alpha = \frac{\text{Distance b/w top and bottom nodes}}{\text{Distance between two supports}/2}$$

$$\tan \alpha = \frac{d_{\text{bottom}} - d_{\text{top}}}{S_{\text{piles}} / 2}$$

d_{bottom} and d_{top} are the distances from the top face to the centroid of the top and bottom nodes. Since the amount of tension bars at the bottom are not known and cannot be calculated without the truss geometry, calculating α is an iterative process.

C.2. Tension Tie Reinforcement

- i. Guess d_{top}
(assume $d_{\text{bottom}} = \text{H-pile embedment} - 6\text{in}$)

c.

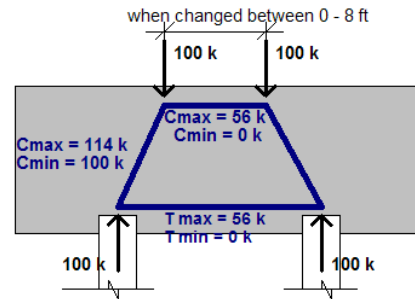

d.

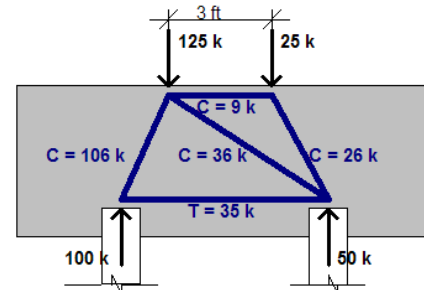

e.

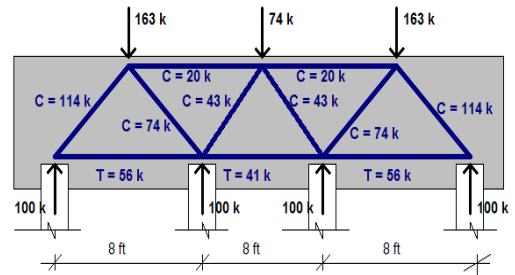

- i. $d_{\text{top}} = 6 \text{ in}$
 $d_{\text{bottom}} = 120 \text{ in} - 24 \text{ in} - 6 \text{ in} = 90.0 \text{ in}$

ii. Calculate α

iii. Calculate Truss Forces

iv. Calculate tension reinforcement area by

$$A = \frac{T}{\Phi \times f_y}$$

Load factor, $\Phi = 0.9$ (LRFD 5.5.4.2)

v. Calculate the nodal zone at the bottom

$$Depth = 2 \text{ in} + \Phi_{bar} + 6 \times \Phi_{bar}$$

The node is assumed to be 2 in above the pile and extends 6bar diameters above the bar. (LRFD Fig 5.6.3.3.2-1)

Calculate $d_{top \text{ bars}}$

Check if $Depth = d_{top \text{ bars}}$

C.3. Nodal Areas - The Bottom Node:

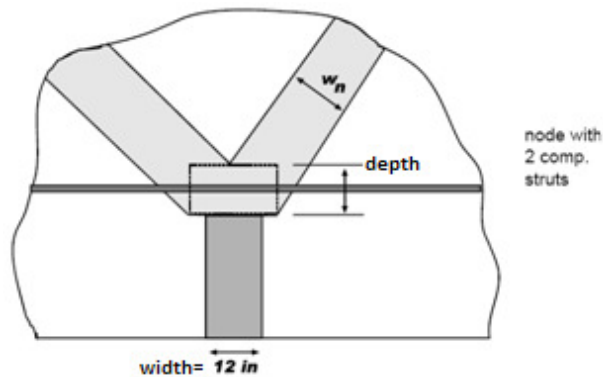

The node at the intersection of strut and tie over the pile is examined. Node with 2 compression struts would govern as shown.

The depth of the tie is calculated in part C.2.

The width of the node is taken as:

$$width = \text{pile thickness} + 2 \text{ in} \times 2 \text{ sides}$$

The width of the compression strut, w_n is found from the geometry of the node

$$w_n = Depth \times \cos \alpha + width \times \sin \alpha$$

$$\text{ii. } \tan \alpha = \frac{90.0 - 6.0 \text{ in}}{48 \text{ in}}$$

$$\alpha = 60.3^\circ$$

$$\text{iii. } C = \frac{P}{\sin \alpha} = \frac{100 \text{ kips}}{\sin(60.3^\circ)} = 115 \text{ kips}$$

$$T = \frac{P}{\tan \alpha} = \frac{100 \text{ kips}}{\tan(60.3^\circ)} = 57 \text{ kips}$$

$$\text{iv. } A = \frac{57 \text{ kips}}{(0.9) \times (60 \text{ ksi})} = 1.06 \text{ in}^2$$

4 #5 bars distributed to 2 faces has

$$A = 1.23 \text{ in}^2 > 1.06 \text{ in}^2$$

$$\text{v. } Depth = 2 \text{ in} + \frac{5 \text{ in}}{8} + 6 \times \frac{5 \text{ in}}{8} = 6.375 \text{ in}$$

$$d_{top \text{ bars}} = 6 \text{ in}$$

~ OK.

$$depth = 6.38 \text{ in}$$

$$width = 12 \text{ in} + 2 \text{ in} \times 2 \text{ sides} = 16 \text{ in}$$

$$w_n = (6.38 \text{ in}) \times \cos(60.3^\circ) + (16 \text{ in}) \times \sin(60.3^\circ) = 17.1 \text{ in}$$

The thickness of the compression block is taken as:
 $thickness = pile\ thickness + 2\ in \times 2\ sides$

Cross sectional area of the compression strut:

$$A_{cs} = w_n \times thickness$$

Tension development length should be developed at the node

(for #11 bars and smaller diameter)

$$l_d = \max \left[\left(1.25 \times A \times \frac{f_y}{\sqrt{f_c}} \right); (0.4 \times \Phi_{bar} \times f_y) \right]$$

C.4. Compressive Struts

$$\varepsilon_s = \frac{T}{A_s \times E_s} < \varepsilon_y$$

$$\varepsilon_1 = \varepsilon_s + (\varepsilon_s + 0.002) \times \cot(\alpha_s)^2$$

$$f_{cu} = \frac{f_c}{0.8 + 170 \times \varepsilon_1} < 0.85 \times f_c$$

$$P_n = f_{cu} \times A_{cs} + f_y \times A_{ss}$$

$$P_r = \Phi_c \times P_n$$

Where $\Phi_c = 0.7$ for compression

C.5. Normal Stresses at the Boundaries of the Nodal Zones:

Compressive stress limit:

$$f_{max} = 0.75 \times \Phi_{bearing} \times f_c$$

Where $\Phi_{bearing} = 0.70$ for a nodal zone with 1 way tension tie

Strut capacity:

$$C_n = f_{max} \times A_{cs}$$

Bearing above the pile:

$$A_{pile} = 15.5\ in^2\ \text{for HP 12 x 53 piles}$$

$$f_{pile} = \frac{100\ kips}{A_{pile}}$$

$$thickness = 12\ in + 2\ in \times 2 = 16\ in$$

$$A_{cs} = (17.1\ in) \times (16\ in) = 273.6\ in^2$$

$$l_d = \max \left[\left(1.25 \times (0.31\ in^2) \times \left(\frac{60\ ksi}{\sqrt{(3.5\ ksi)}} \right) \right); (0.4 \times (0.625\ in) \times (60\ ksi)) \right] = 15\ in$$

$$\varepsilon_s = \frac{57\ kips}{(1.23\ in^2) \times (29000\ ksi)} < 0.002$$

$$\varepsilon_s = 0.0016 < 0.002$$

$$\varepsilon_1 = 0.0016 + (0.0016 + 0.002) \times \cot(60.3^\circ)^2 = 0.0028$$

$$f_{cu} = \frac{(3.5\ ksi)}{0.8 + 170 \times (0.0028)} < 0.85 \times (3.5\ ksi)$$

$$f_{cu} = 2.76\ ksi < 2.98\ ksi$$

$$P_n = (2.76\ ksi) \times (273.6\ in^2) = 755.1\ kips$$

$$P_r = (0.7) \times (755.1\ ksi) = 528.6\ kips$$

$$C = 115\ kips < 528.6\ kips, \text{ OK}$$

$$f_{max} = 0.75 \times 0.70 \times 3.5\ ksi = 1.838\ ksi$$

$$C_n = (1.838\ ksi) \times (273.6\ in^2) = 502.7\ kips$$

$$f_{pile} = \frac{100\ kips}{15.5\ in^2} = 6.45\ ksi$$

Bearing capacity:

$$P_{bearing} = \Phi_{bearing} \times (0.85 \times f_c \times A_{bearing} \times m)$$

Where m is modification factor, to be determined according to LRFD 5.7.5

A_2 area is assumed to be (abutment thickness x abutment thickness)

$$A_2 = 38 \text{ in} \times 38 \text{ in}$$

$$m = \sqrt{\frac{A_2}{A_{bearing}}} < 2$$

$$A_{bearing} = 12 \text{ in} \times 12 \text{ in} = 144 \text{ in}^2$$

$$m = \sqrt{\frac{A_2 = 1444 \text{ in}^2}{144}} = 3.17 < 2$$

$$m = 2$$

$$P_{bearing} = (0.70)$$

$$\times (0.85 \times 3.5 \text{ ksi} \times 144 \text{ in}^2 \times 2)$$

$$= 599.8 \text{ kips}$$

$$> 100 \text{ kips, OK}$$

C.6. Nodal Areas - The Top Node:

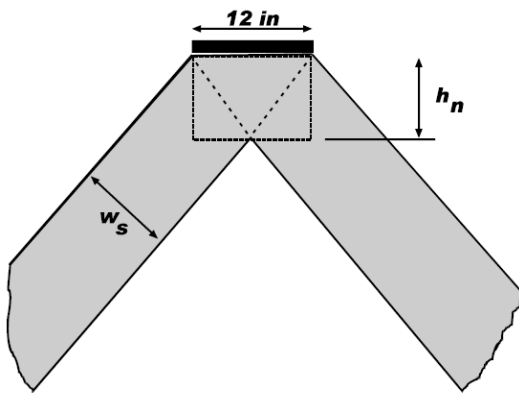

The node at the intersection of two compression struts below the girder is examined.

The girder bearing plate is assumed to be 12 in x 12 in.

$$w_s = 12 \text{ in} \times \sin \alpha$$

$$w_s = 12 \text{ in} \times \sin(60.3^\circ) = 10.42 \text{ in}$$

Bearing capacity under the bearing plate:

$$P_{pl} = \Phi_{bearing} \times (0.85 \times f_c \times 12 \text{ in} \times 12 \text{ in} \times m)$$

Where m is assumed to be the same as calculated above

$$P_{pl} = (0.70) \times (0.85 \times 3.5 \text{ ksi} \times 12 \text{ in} \times 12 \text{ in}$$

$$\times 2) = 599.8 \text{ kips}$$

$$> 200 \text{ kips, OK}$$

Strut Capacity:

$$C_{cs} = \Phi_{strut} \times 0.85 \times f_c \times w_s^2$$

$$C_{cs} = (0.70) \times 0.85 \times 3.5 \text{ ksi} \times 10.42^2$$

$$= 226.1 \text{ kips}$$

$$> 115 \text{ kips, OK}$$

C.7. Transverse Reinforcement

The area of reinforcement that should be equally distributed to both faces in each direction

$$A_{tr} = 0.003 \times A_g$$

$$s_{max} = 12 \text{ in}$$

$$A_{tr} = 0.003 \times \left(38 \text{ in} \times \frac{12 \text{ in}}{1 \text{ ft}} \right) = 1.368 \frac{\text{in}^2}{\text{ft}}$$

$$\frac{A_{tr}}{2} = \frac{1.368 \frac{\text{in}^2}{\text{ft}}}{2} = 0.68 \frac{\text{in}^2}{\text{ft}} \text{ on each face}$$

$$\#5 \text{ bars @ } 5 \text{ in has } A = 0.74 \frac{\text{in}^2}{\text{ft}}$$

D. Abutment Module – Pile Joint

Free body diagram of the pile block out in the abutment body cross section is shown. The moment and shear created by the earth pressure is resisted by the force applied to the abutment by the pile.

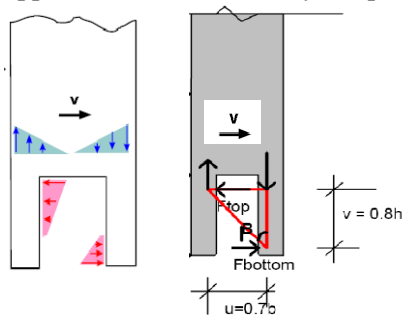

The resultants of the forces applied by the pile are assumed to be $0.8 h_{pile}$ apart from each other, where h_{pile} is the pile block out depth.

$$\sum M = F_{top} \times 0.8 \times h_{pile} - M_{lateral \text{ earth pressure}} = 0$$

$h_{pile} = 2 \text{ ft}$ is a length that allows easy forming and controls misalignment problem of the piles. (For higher pile embedment lengths, the reinforcement around the block out can be extended around the pile.)

$$M_{lateral \text{ earth pressure}} = \left[\frac{(10 \text{ ft})}{3} - 0.1 \times 2 \text{ ft} \right] \times \left(2.63 \frac{\text{kip}}{\text{ft}} \right) + \left[\frac{(10 \text{ ft})}{2} - 0.1 \times 2 \text{ ft} \right] \times \left(2.08 \frac{\text{kip}}{\text{ft}} \right) = 18.2 \frac{\text{kip ft}}{\text{ft}}$$

The abutment module is assumed to be 8.5 ft long, supported by two piles, equally sharing the load.

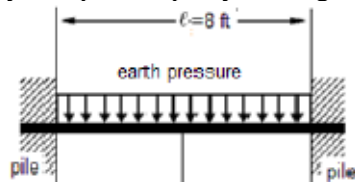

also:

$$\sum F = F_{top} - F_{bottom} - V_{lateral\ earth\ pressure} = 0$$

D.1. Tie Reinforcement around the block out

$$A_{tie} = \frac{F_{top}}{f_y}$$

D.2. Vertical reinforcement around the block out

$$A_{vertical} = \frac{M_{lateral\ earth\ pressure}}{0.7 \times b \times f_y}$$

The distance between the vertical truss members is assumed to be 0.7 times the thickness of the abutment, b.

At one pile,

$$M_{lateral\ earth\ pressure} = \left(18.2 \frac{kip\ ft}{ft}\right) \times \frac{8.5\ ft}{2} = 77.5\ kip\ ft$$

$V_{lateral\ earth\ pressure}$

$$= \left(2.63 \frac{kip}{ft} + 2.08 \frac{kip}{ft}\right) \times \frac{8.5\ ft}{2} = 20.0\ kip$$

$$\sum M = F_{top} \times 0.8 \times (2\ ft) - 77.5\ kip\ ft = 0$$

$$F_{top} = 48.4\ kip$$

$$w_{top} = \frac{48.4\ kip}{1\ ft} = 48.4 \frac{kip}{ft} \text{ distributed to half pile embedment}$$

$$\sum F = (48.4\ kip) - F_{bottom} - (20.0\ kip) = 0$$

$$F_{bottom} = 28.4\ kip$$

$$A_{tie} = \frac{48.8 \frac{kip}{ft}}{60\ ksi} = 0.80 \frac{in^2}{ft}$$

4 bars @ 5 in through the block out has
 $A = 0.94\ in^2$ with two legs

$$A_{vertical} = \frac{77.5\ kip\ ft}{0.7 \times (38\ in) \times (60\ ksi)} = 0.58\ in^2$$

3 # 4 bars have $A = 0.59\ in^2$

E. Abutment Module-Module Joint

Shear key joint is picked and proportioned according to the PCI connection manual.

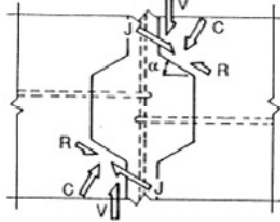

$$J = V \times \sin \alpha$$

$$C = V \times \cos \alpha$$

$$R = C \times \tan \phi$$

$$J < R \text{ must be satisfied}$$

where $\tan \phi = 0.6$

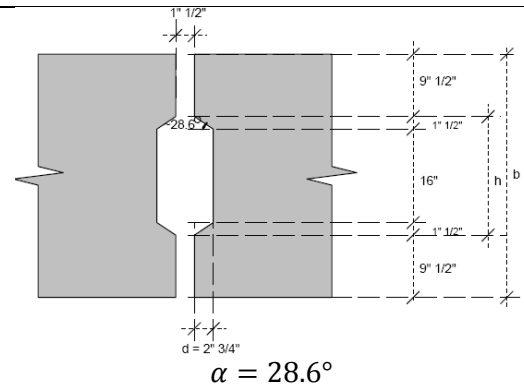

Preliminary Pier Cap Design Example: This example studies a *pier cap* supporting a 90 ft span bridge. The pier cap is 42 ft long and is supported by 3 piers. The bridge accommodates three lanes. The cross section is a rectangle and is 3.5 ft (b) x 3.5 ft (h). The design strength of concrete is 4 ksi and the reinforcement bars have 60ksi yield strength.

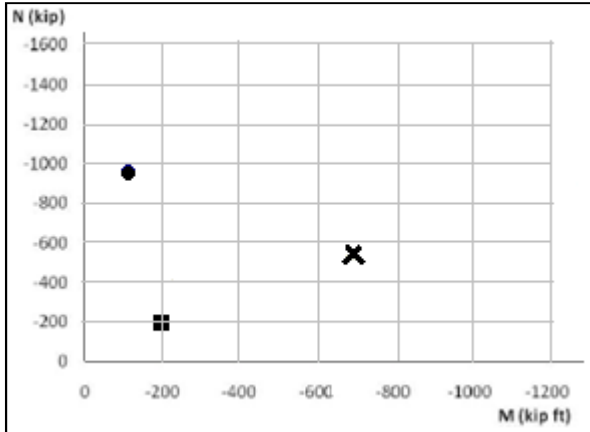
Procedure	Calculations								
<p>A. Analysis of the Pier frame</p> <p>A.1. Define the Types of Loads:</p> <ul style="list-style-type: none"> • Dead load of girders and deck • Future wearing surface • Live Load • Vehicle Braking • Wind Load • Loads created by Temperature changes <p>Consider AASHTO Strength 1, Strength 3, Strength 5 and Service 1 load combinations.</p> <p>A.2. Analyze the Pier Frame</p> <p>The frame under the loads defined above is analyzed using,</p> <ul style="list-style-type: none"> - Rigid column to cap joints to maximize the reactions at these joints 	<ul style="list-style-type: none"> • For a 90 ft span bridge, Pick: Six 45 in prestressed girders with self weight of, $w = 583 \frac{lb}{ft}$ 8.5 in thick deck • $Wearing\ surface = 20 \frac{lb}{ft^2}$ • HL 93 + Lane Load, placed to create the worse reactions • Maximum of 25% of truck or tandem load and 5% of truck/tandem + lane load • Wind load is applied on vehicles, on superstructure, on substructure in transverse and longitudinal directions of the bridge <p>SAP 2000 Analysis results showed that the reactions in the transverse direction of the bridge govern the ones in the longitudinal direction of the bridge.</p> <ul style="list-style-type: none"> - The factored critical moment and axial load reactions at the column to cap joints:  <table border="1"> <caption>Data points from the N vs M plot</caption> <thead> <tr> <th>M (kip ft)</th> <th>N (kip)</th> </tr> </thead> <tbody> <tr> <td>-150</td> <td>-950</td> </tr> <tr> <td>-200</td> <td>-200</td> </tr> <tr> <td>-700</td> <td>-550</td> </tr> </tbody> </table>	M (kip ft)	N (kip)	-150	-950	-200	-200	-700	-550
M (kip ft)	N (kip)								
-150	-950								
-200	-200								
-700	-550								

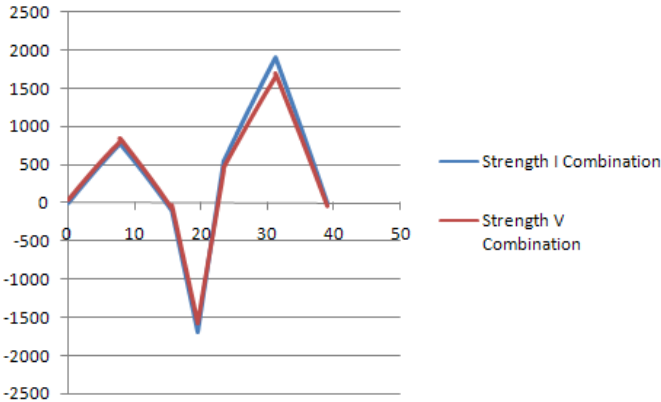
<p>- Pinned column to cap joints to maximize the mid-span reactions at the pier cap</p>	<p>- The factored moment diagram for the pier cap (M in ft kip):</p>  <p>$M_d = 1915 \text{ kip ft}$ $M_d = -1187 \text{ kip ft}$ (at the edge of the column) $V_{design} = 550 \text{ kip}$</p>
<p>B. Reinforcement Calculations for the Pier Cap</p> <p>B.1. Positive Moment Reinforcement</p> <p>Neutral axis depth:</p> $c = \frac{A \times f_y}{0.85 \times f_c \times \beta_1 \times b}$ <p>Effective depth:</p> $d_1 = h - cover - \Phi_{stirrup} - \frac{\Phi_{bar}}{2}$ $d_2 = d_1 - \frac{\Phi_{bar}}{2} - 1.5 \times \Phi_{bar} - \frac{\Phi_{bar}}{2}$ $d = \frac{d_{1st \text{ layer}} + d_{2nd \text{ layer}}}{2}$ <p>Tension steel strain:</p> $\epsilon = \epsilon_c \times \frac{d - c}{c}$ <p>Resisting moment:</p> $M_r = \Phi \times A \times f_y \times \left(d - \frac{c \times \beta_1}{2} \right)$ <p>where resistance factor for flexure is $\Phi = 0.9$</p>	<p>Try: 11 # 10 bars in two layers #4 stirrups Clear cover: 2.5 in $A = 13.5 \text{ in}^2$</p> $c = \frac{(13.5 \text{ in}^2) \times (60 \text{ ksi})}{0.85 \times (4 \text{ ksi}) \times (0.85) \times (42 \text{ in})}$ $c = 6.67 \text{ in}$ $d_1 = 42 \text{ in} - 2.5 \text{ in} - 0.5 \text{ in} - \frac{1.25 \text{ in}}{2} = 38.4 \text{ in}$ $d_2 = 38.4 \text{ in} - 2.5 \times (1.25 \text{ in}) = 35.3 \text{ in}$ $d = \frac{38.4 \text{ in} + 35.3 \text{ in}}{2} = 36.8 \text{ in}$ $\epsilon = 0.003 \times \frac{36.8 \text{ in} - 6.7 \text{ in}}{6.7 \text{ in}}$ $\epsilon = 0.014 > 0.005$ $M_r = (0.9) \times (13.5 \text{ in}^2) \times (60 \text{ ksi}) \times \left(36.8 \text{ in} - \frac{6.67 \text{ in} \times 0.85}{2} \right)$ $M_r = 2064 \text{ kip ft} > M_d = 1915 \text{ kip ft}$

B.2. Negative Moment Reinforcement

Neutral axis depth:

$$c = \frac{A \times f_y}{0.85 \times f_c \times \beta_1 \times b}$$

Effective depth:

$$d = h - \text{cover} - \Phi_{stirrup} - \frac{\Phi_{bar}}{2}$$

Tension steel strain:

$$\varepsilon = \varepsilon_c \times \frac{d - c}{c}$$

Resisting moment:

$$M_r = \Phi \times A \times f_y \times \left(d - \frac{c \times \beta_1}{2}\right)$$

where $\Phi = 0.9$ for flexure**B.3. Shear Check**

Effective shear depth:

$$d_v = \max \left[d - \frac{c \times \beta_1}{2}; 0.9 \times d; 0.72 \times h \right]$$

where factor for ability of diagonally cracked concrete to transmit tension: $\beta = 1$

Contribution of concrete:

$$V_c = 0.0316 \times \beta \times \sqrt{f_c} \times b \times d_v$$

No reinforcement is needed if:

$$0.5 \times \Phi \times V_c > V_d$$

where resistance factor for shear, $\Phi = 0.9$

Try: 7 # 10 bars in one layer

#4 stirrups

Clear cover: 2.5 in

$$A = 8.6 \text{ in}^2$$

$$c = \frac{(8.6 \text{ in}^2) \times (60 \text{ ksi})}{0.85 \times (4 \text{ ksi}) \times (0.85) \times (42 \text{ in})}$$

$$c = 4.2 \text{ in}$$

$$d = 42 \text{ in} - 2.5 \text{ in} - 0.5 \text{ in} - \frac{1.25 \text{ in}}{2} = 38.4 \text{ in}$$

$$\varepsilon = 0.003 \times \frac{38.4 \text{ in} - 4.2 \text{ in}}{4.2 \text{ in}}$$

$$\varepsilon = 0.024 > 0.005$$

$$M_r = (0.9) \times (8.6 \text{ in}^2) \times (60 \text{ ksi})$$

$$\times \left(38.4 \text{ in} - \frac{4.2 \text{ in} \times 0.85}{2} \right)$$

$$= 1417 \text{ lb ft}$$

$$M_r = 1417 \text{ kip ft} > M_d = 1187 \text{ kip ft}$$

Try: 2 # 5 stirrups @ 4 in

Clear cover: 2.5 in

$$\frac{A_v}{s} = 0.307 \frac{\text{in}^2}{\text{in}}$$

$$d_v = \max \left[36.8 \text{ in} - \frac{6.67 \text{ in} \times 0.85}{2}; 0.9 \times 36.8 \text{ in}; 0.72 \right.$$

$$\left. \times 42 \text{ in} \right] = 34.0 \text{ in}$$

$$V_c = 0.0316 \times (1) \times \sqrt{4 \text{ ksi}} \times (42 \text{ in}) \times (34.0 \text{ in})$$

$$= 90.2 \text{ kip}$$

$$0.5 \times (0.9) \times (90.2 \text{ kip}) = 40.6 \text{ kip} < 550 \text{ kip}$$

Shear reinforcement is required.

<p>Contribution of transverse reinforcement:</p> $V_s = \frac{A_v \times f_y \times d_v \times (\cot \theta + \cot \alpha) \times \sin \alpha}{s}$ <p>Total factored Shear Capacity:</p> $V_r = \text{minimum} [\Phi \times (V_c + V_s); \Phi \times 0.25 \times f_c \times b_v \times d_v]$ <p>Check minimum transverse reinforcement:</p> $\frac{A_{vmin}}{s} = \frac{0.0316 \times \sqrt{f_c} \times b_v}{f_y}$	$V_s = 0.307 \frac{\text{in}^2}{\text{in}} \times (60 \text{ ksi}) \times 34.0 \text{ in} \times (\cot(\frac{\pi}{4}) + \cot(\frac{\pi}{2})) \times \sin(\frac{\pi}{4}) = 626.3 \text{ kip}$ <p>Assumption: Angle of inclination of diagonal compression stress: $\theta = \frac{\pi}{4}$</p> <p>Angle of transverse reinforcement to longitudinal axis: $\alpha = \frac{\pi}{2}$</p> $V_r = \text{minimum} [(0.9) \times (90.2 \text{ kip} + 626.3 \text{ kip}); 0.25 \times (4 \text{ ksi}) \times (42 \text{ in}) \times (34.0 \text{ in})] = 644.8 \text{ kip} > V_{design} = 550 \text{ kip}$ $\frac{A_{vmin}}{s} = \frac{0.0316 \times \sqrt{4 \text{ ksi}} \times (42 \text{ in})}{(60 \text{ ksi})} = 0.044 \text{ in} < 0.31 \text{ in}$
<p>C. Pier Cap to Column Joints</p> <p>The connections type given here is the grouted pocket connection. Pockets in the precast cap are designed to accommodate the connecting bars coming from the column. The rest of the pocket is grouted.</p> <p>The joints are considered to be the upper extension of the column and should resist the axial load and moment reactions at these regions.</p> <p>N-M interaction diagrams for various connector reinforcements are prepared. The reinforcement belonging to the curve enveloping the critical reactions is picked as connection reinforcement</p>	

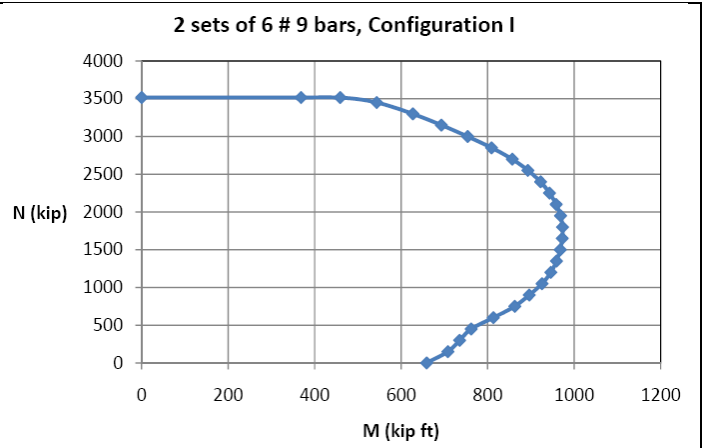
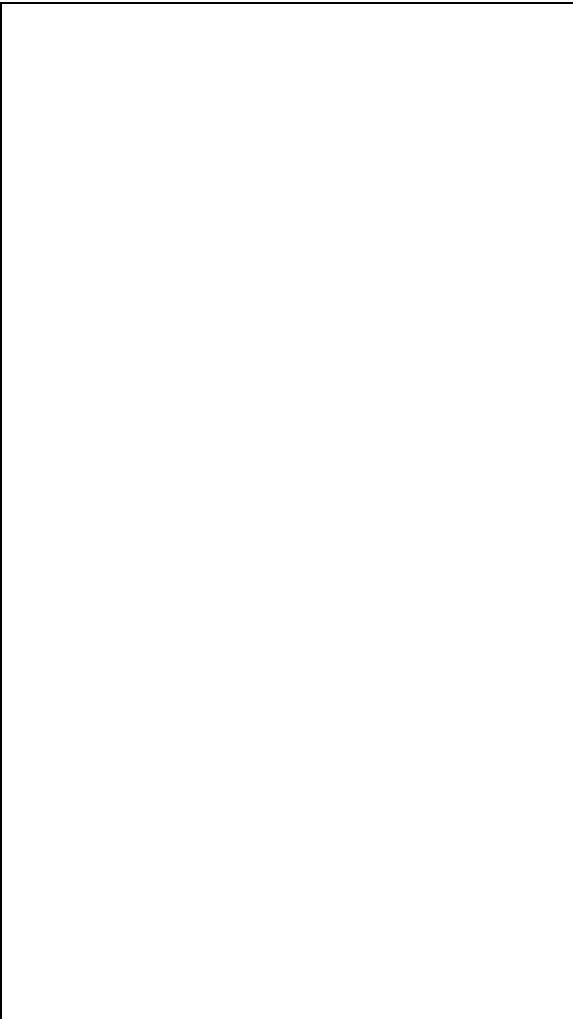

The capacity that 2 sets of 6#9 bars in the circular column provide is shown above. (RCCOLA Analysis) Since this envelopes the critical axial load and moments found in part A, the connectors picked provide the required capacity. The configuration of the connector bars is shown below.

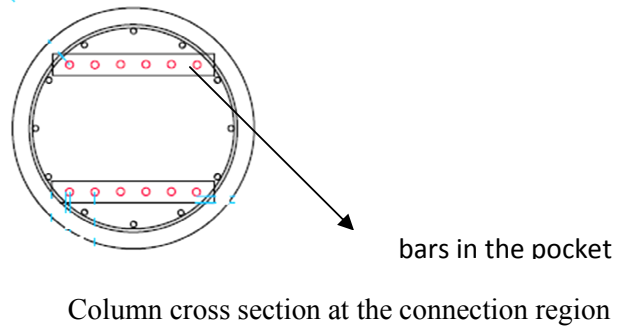

D. Alternative Pier Cap Cross Section

Inverted U cross section for the pier cap can be considered to reduce the weight of the cap. The negative moment regions should be solid to be able to use the same design as the solid pier cap as well as to accommodate the column to pier cap connection. The neutral axis for the positive moment is in the top flange, therefore the same positive moment reinforcement can be used.

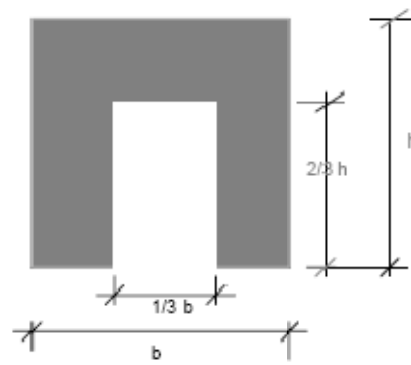

$$h = 3.5 \text{ ft}$$

$$b = 3.5 \text{ ft}$$

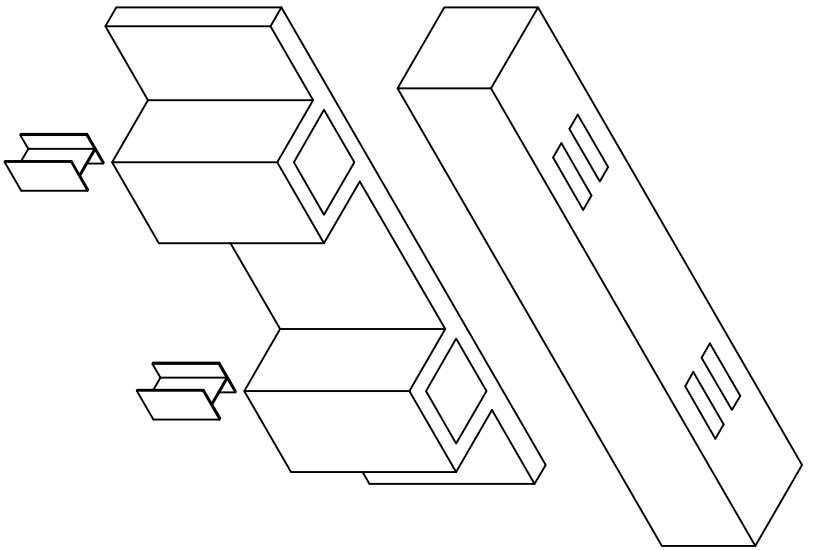

Isometric View 1

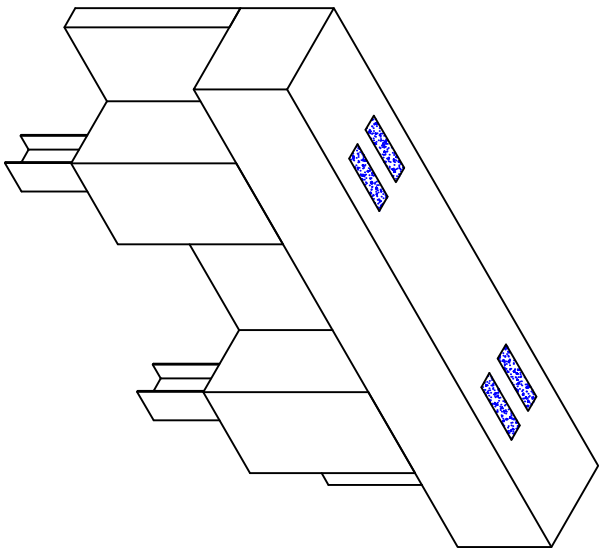

Isometric View 2

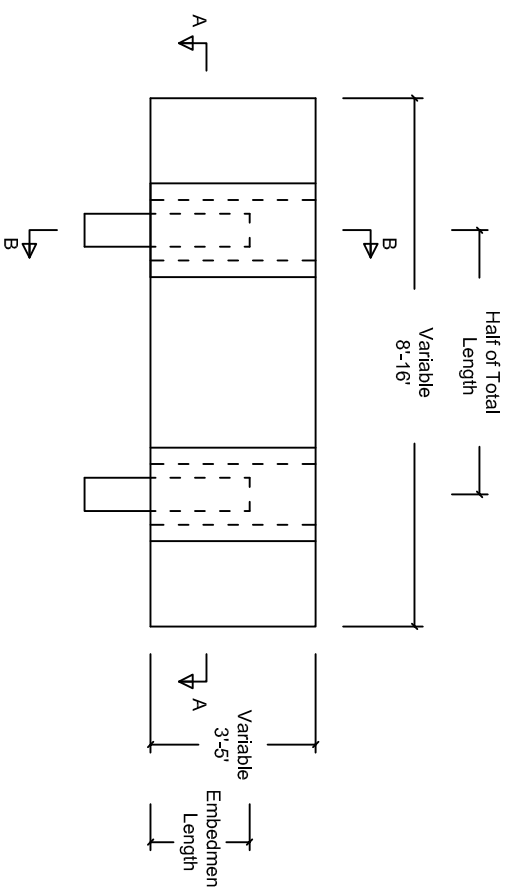

Elevation View

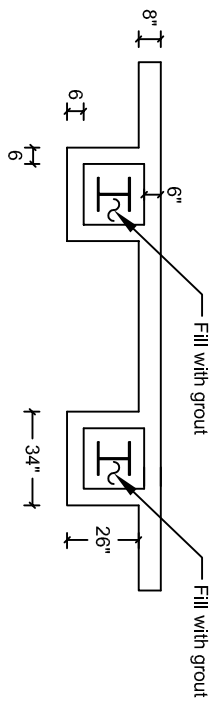

Section A-A

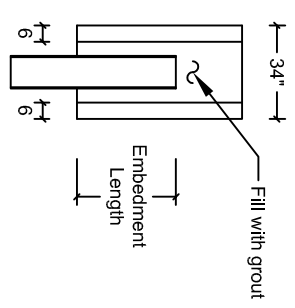

Section B-B

Minimum of 3' embedment length is recommended.

NEW ABUTMENT SYSTEM 3'-5'	
UNIVERSITY OF WISCONSIN-MADISON PROJECT: EFFICIENT DESIGN OF PRECAST CONCRETE SUBSTRUCTURES FOR BRIDGES	
DATE:	December 2010

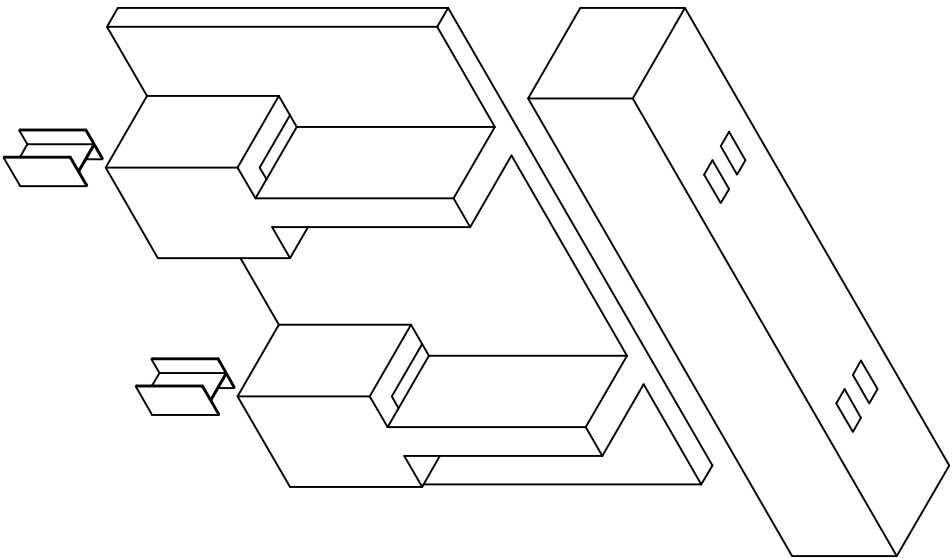

Isometric View 1

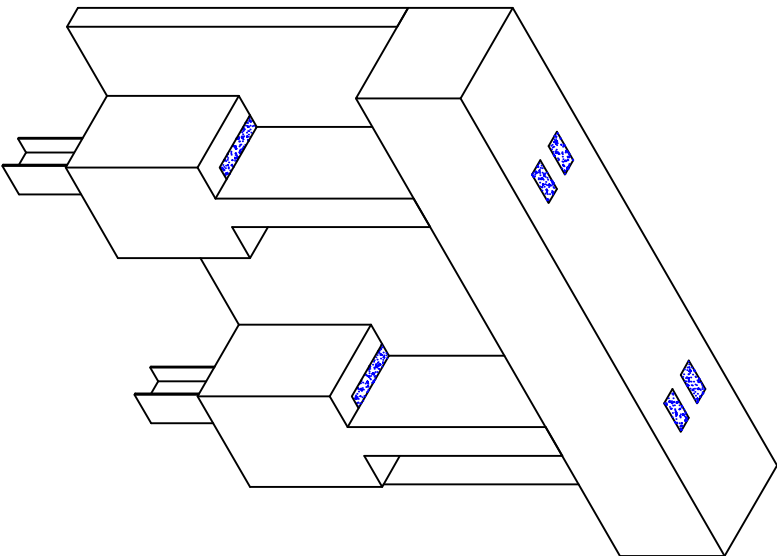

Isometric View 2

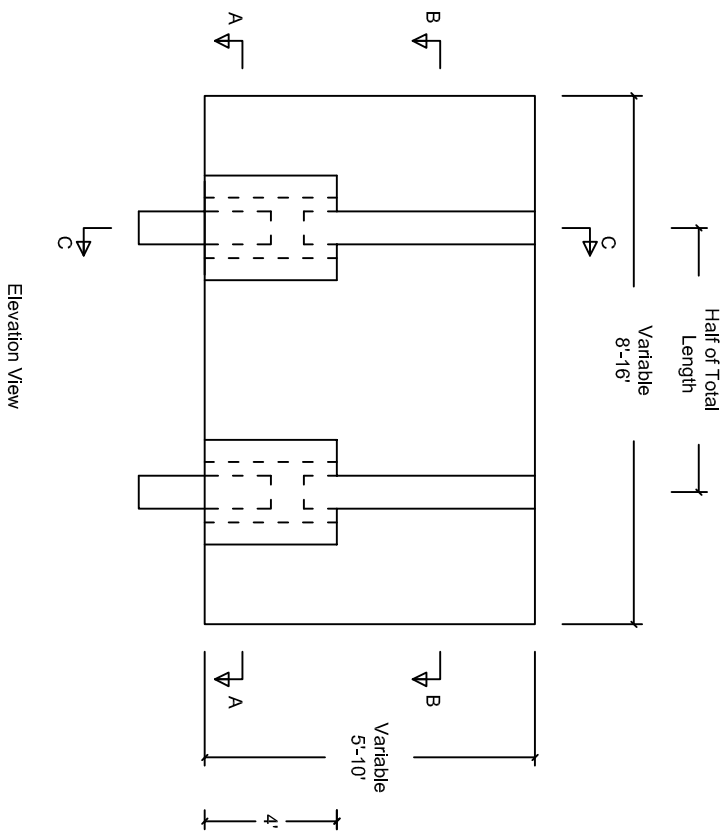
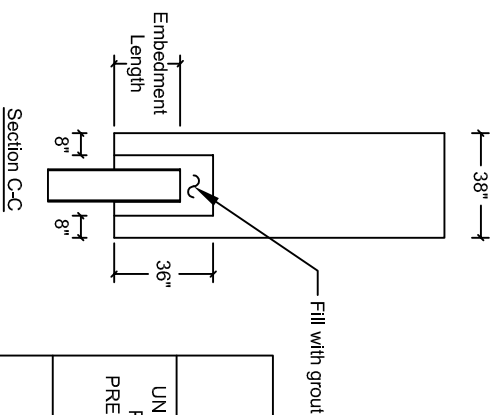
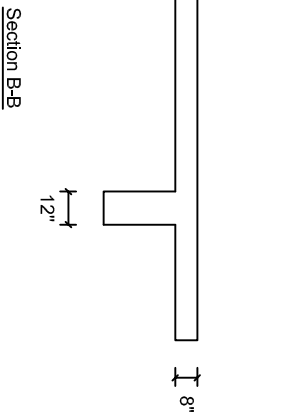
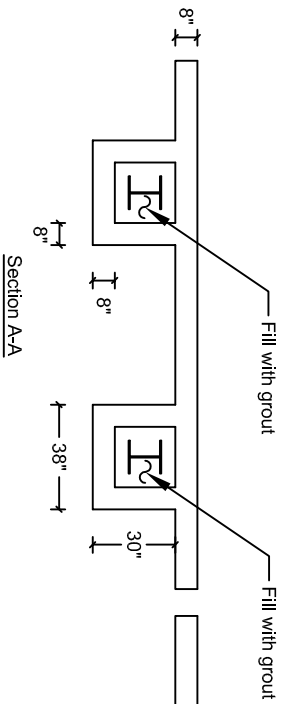

NEW ABUTMENT SYSTEM
5-10'

UNIVERSITY OF WISCONSIN-MADISON
PROJECT: EFFICIENT DESIGN OF
PRECAST CONCRETE SUBSTRUCTURES
FOR BRIDGES

DATE: December 2010

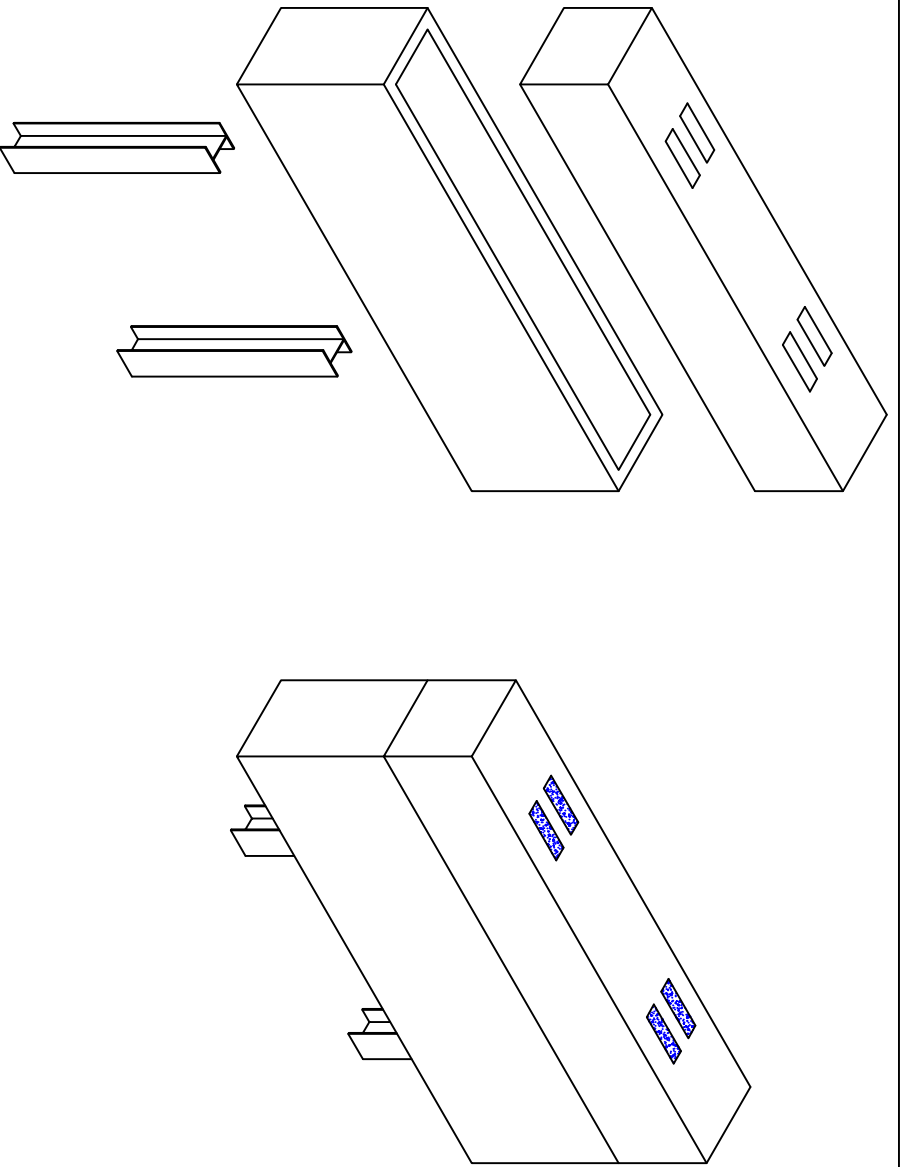

Isometric View

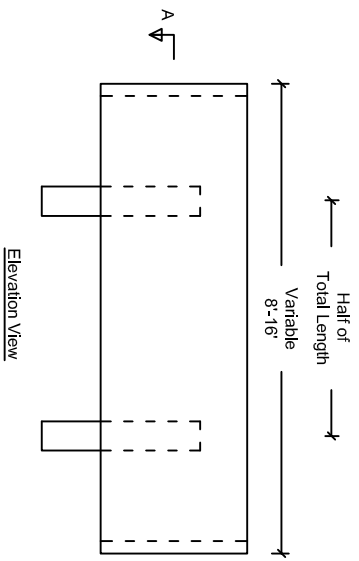

Elevation View

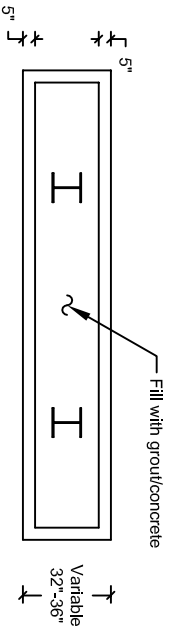
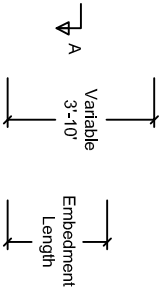

Section A-A

Minimum of 3' pile embedment length is recommended.

Alternative Abutment System
Pile Bent Cap with Hollow Wall Panels

UNIVERSITY OF WISCONSIN-MADISON
PROJECT: EFFICIENT DESIGN OF
PRECAST CONCRETE SUBSTRUCTURES
FOR BRIDGES

DATE:
December 2010

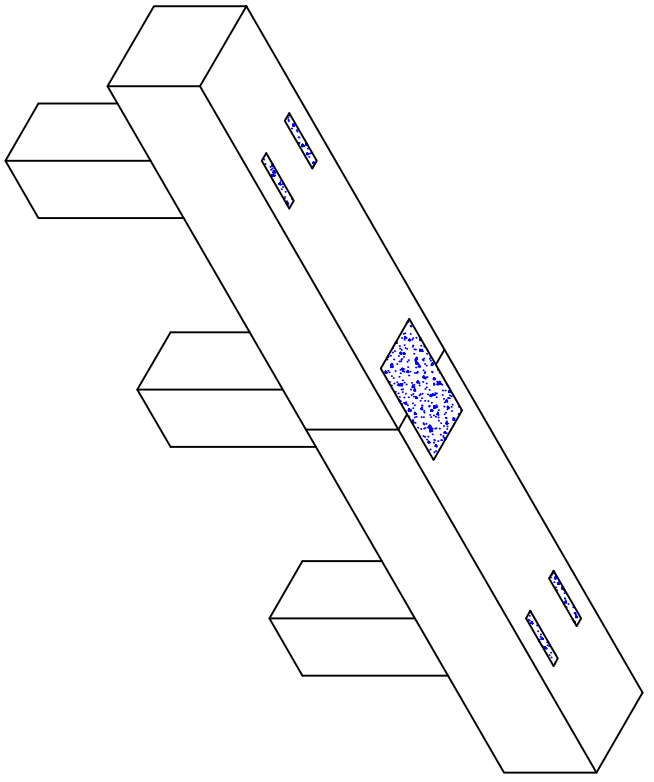

Isometric View

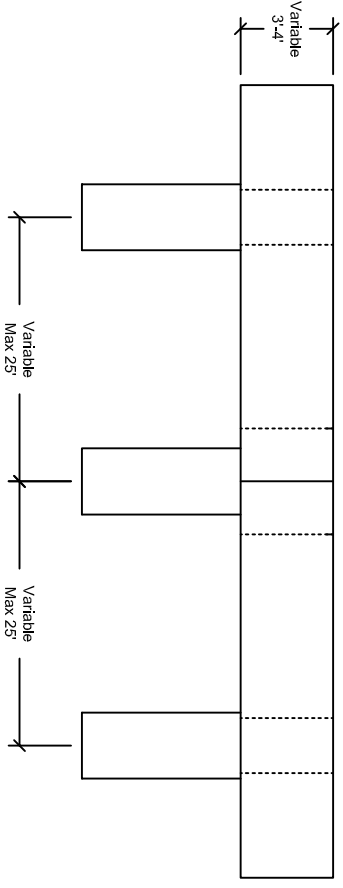

Elevation View

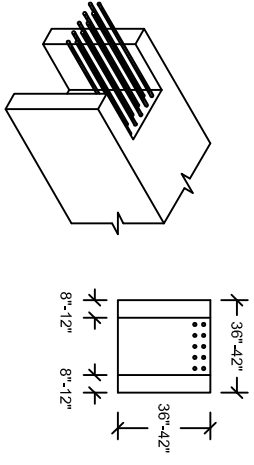

Alternative 1

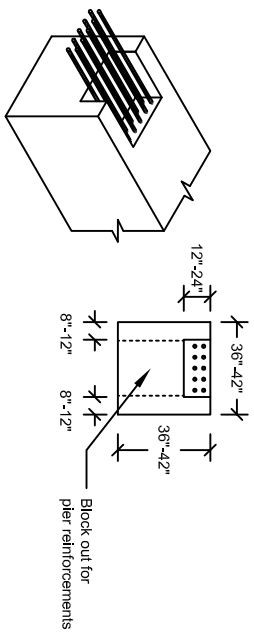

Alternative 2

Top of the bent cap will be manufactured as stepped heights since each girder will have different elevations. The alternative to this application might be putting precast tops under each girder to have different elevations for each of them and then connecting them to bent cap by means of rebars that have been drilled into cap.

Dimensions of the cross section are also variable depending on each project. Those shown here are just examples.

It is best to apply this method when there is cast in place piers with reinforcements already put in.

Bent Cap Connection Type #2 Spliced Reinforcement Connection	
UNIVERSITY OF WISCONSIN-MADISON PROJECT: EFFICIENT DESIGN OF PRECAST CONCRETE SUBSTRUCTURES FOR BRIDGES	
DATE:	December 2010

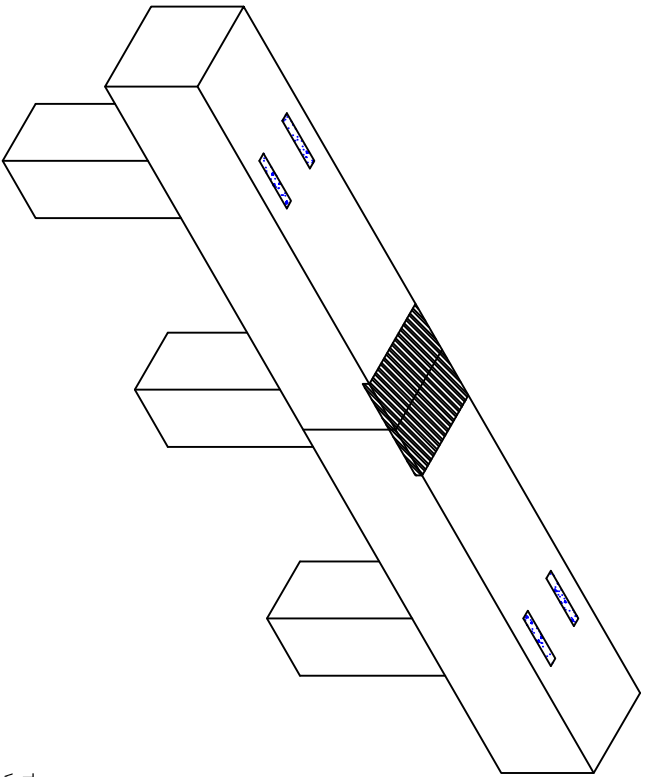

Isometric View

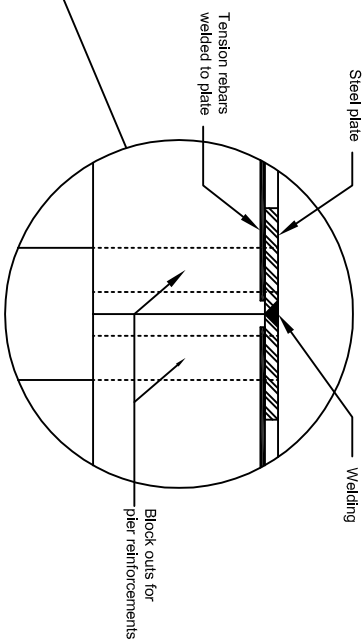

Steel plate

Tension rebars welded to plate

Welding

Block outs for pier reinforcements

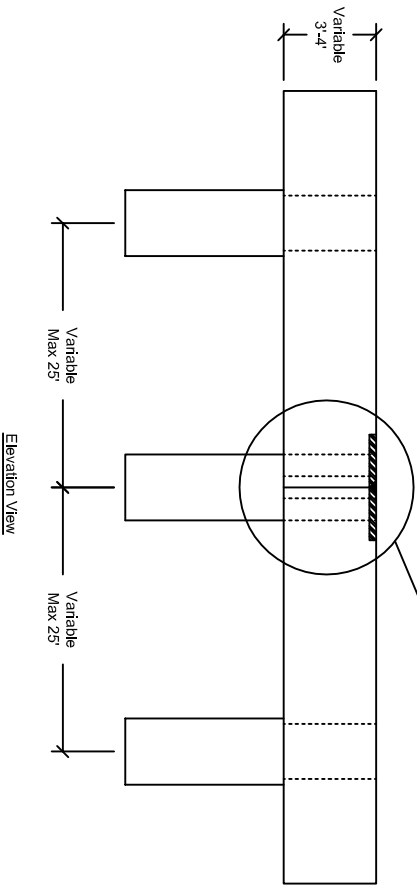

Elevation View

Top of the bent cap will be manufactured as stepped heights since each girder will have different elevations. The alternative to this application might be putting precast tops under each girder to have different elevations for each of them and then connecting them to bent cap by means of rebars that have been drilled into cap.

The steel plate that will be used in this case should be stainless steel not to have a corroded connection after being exposed to water and salt. In addition to that, since the two plates will be welded to each other, the fatigue stress for that welded part should be checked and verified that it is under the permissible limit not to have a catastrophic brittle failure.

Bent Cap Connection Type #1
Welded Steel Plate Connection

UNIVERSITY OF WISCONSIN-MADISON
PROJECT: EFFICIENT DESIGN OF
PRECAST CONCRETE SUBSTRUCTURES
FOR BRIDGES

DATE: December 2010