



Product and Facility Design for Hydroelectric Generators in Malawi



Joshua Miller, Thomas Lacksonen, University of Wisconsin-Stout

Problem

About 10% of the population has access to reliable electricity. Kerosene generators/lamps are used in living spaces.



Solution

Hastings Mkanadawire, a Mandela Young African Leaders fellow, created homemade hydro electric generators from recycled materials.

Project History

- 2014 Summer – Mkanadawire visits UW-Stout
- 2014 Fall – Stout students create new generator design
- 2015 Spring – Stout students design manufacturing facility
- 2015 Summer – A trip to Malawi is planned
- 2016 January – The trip to Malawi occurs
- 2016 February – New designs are created



Initial Project Evaluation

- The power output of the generator
- The repeatability of the proposed manufacturing process/design for mass manufacture
- The cost to build and maintain the final product/process



The Original Questions

- Product Design
 - Limited Material
 - Scrap Material
- Facility Design
 - Safety Tradeoffs
 - Machines and available processes
- Quality Procedures
- Can the country produce generators?

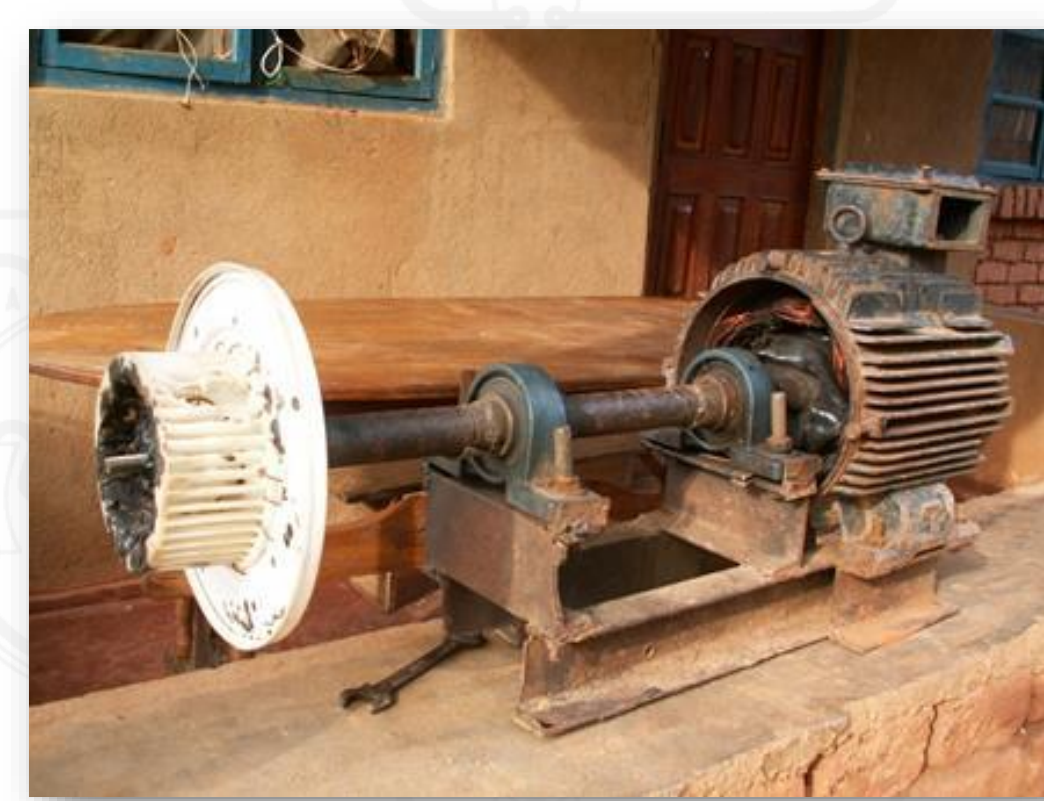

Above is a photo of one of Hastings' original generators



Above is an example of a first world generator

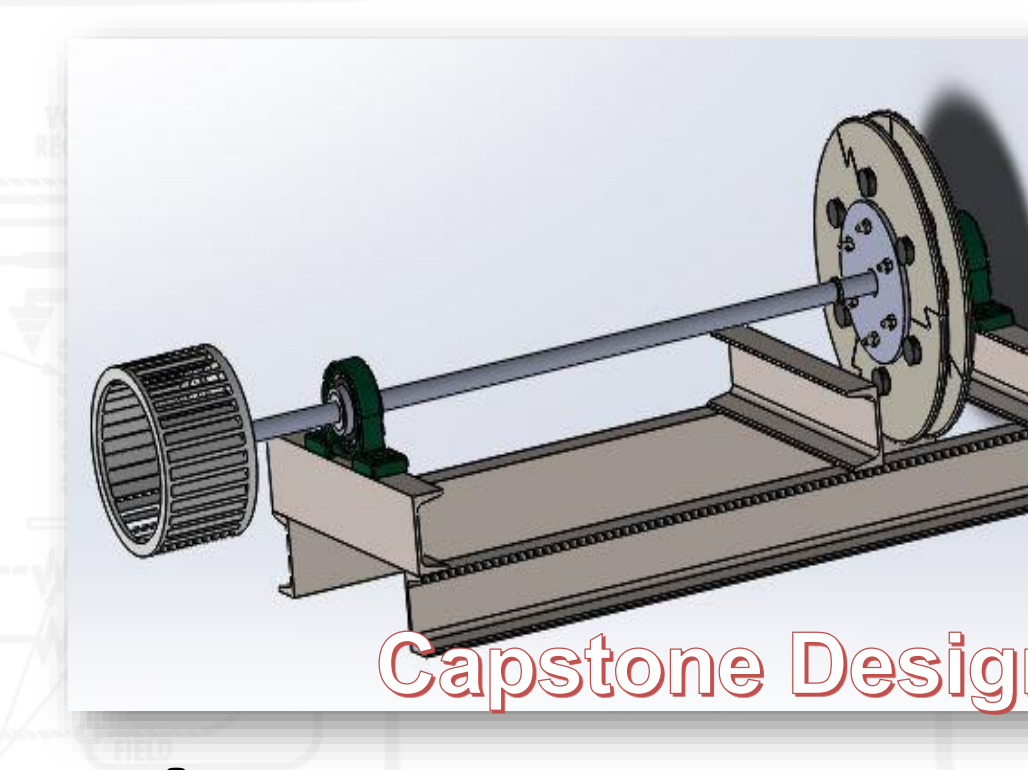

Capstone Design

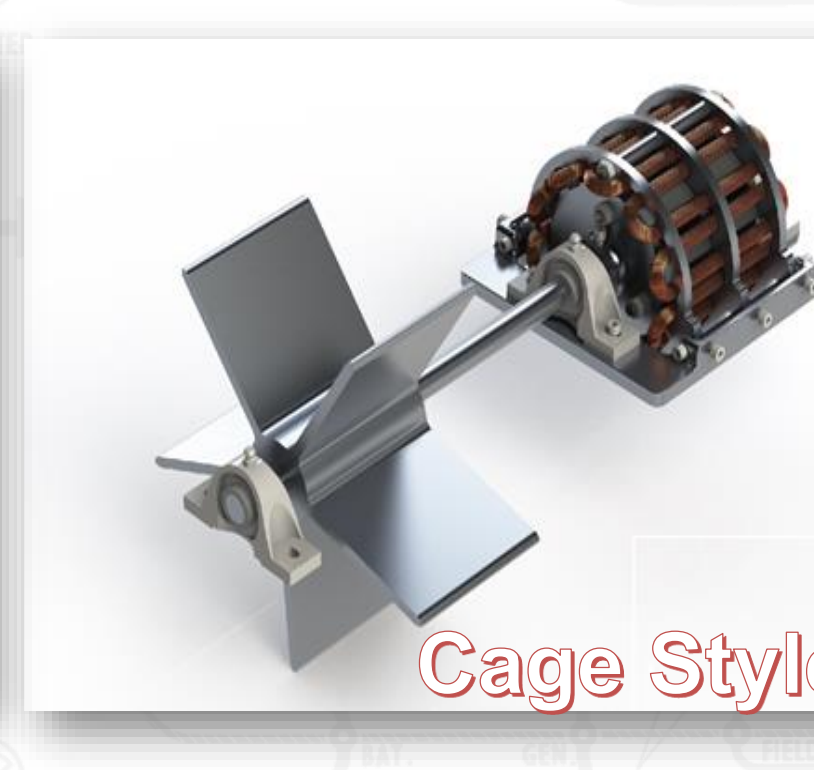

Cage Style

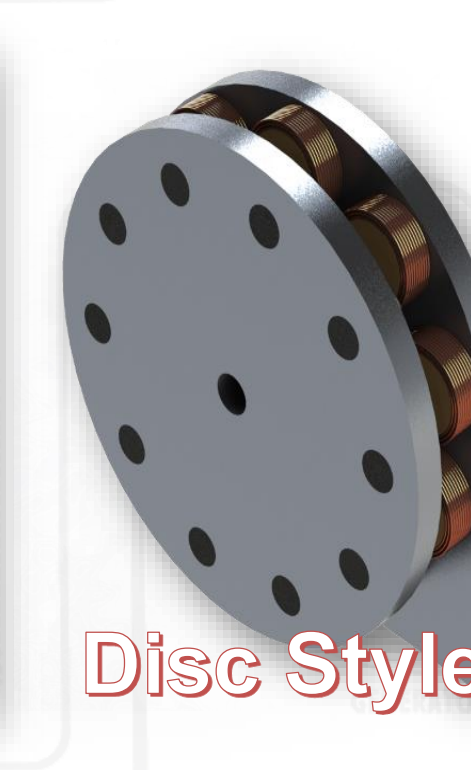

Disc Style

The New Designs

- Built from "scratch" and recycled components
- Can use either purchased metals or melted scrap
- Uses sand casting to produce parts
- Can use electromagnets to eliminate expensive magnets

Capstone

- + Easy to assembly
- Epoxy is costly

Cage Style

- + Strong, compact build
- More parts – slightly difficult to assemble

Disc Style

- + Similar to capstone, but metal cast
- Eddy currents may generate too much heat

Issues

- The scope of the project continued to change
- Epoxy: cannot be used due to price/volume
- Epoxy: cannot build/maintain molds
- Current design takes 5 days to build
- Processes:** not in place, time studies could not be done
- Facility:** not built
- Safety procedures:** not followed, equipment not used
- Power generation sites:** hard to reach

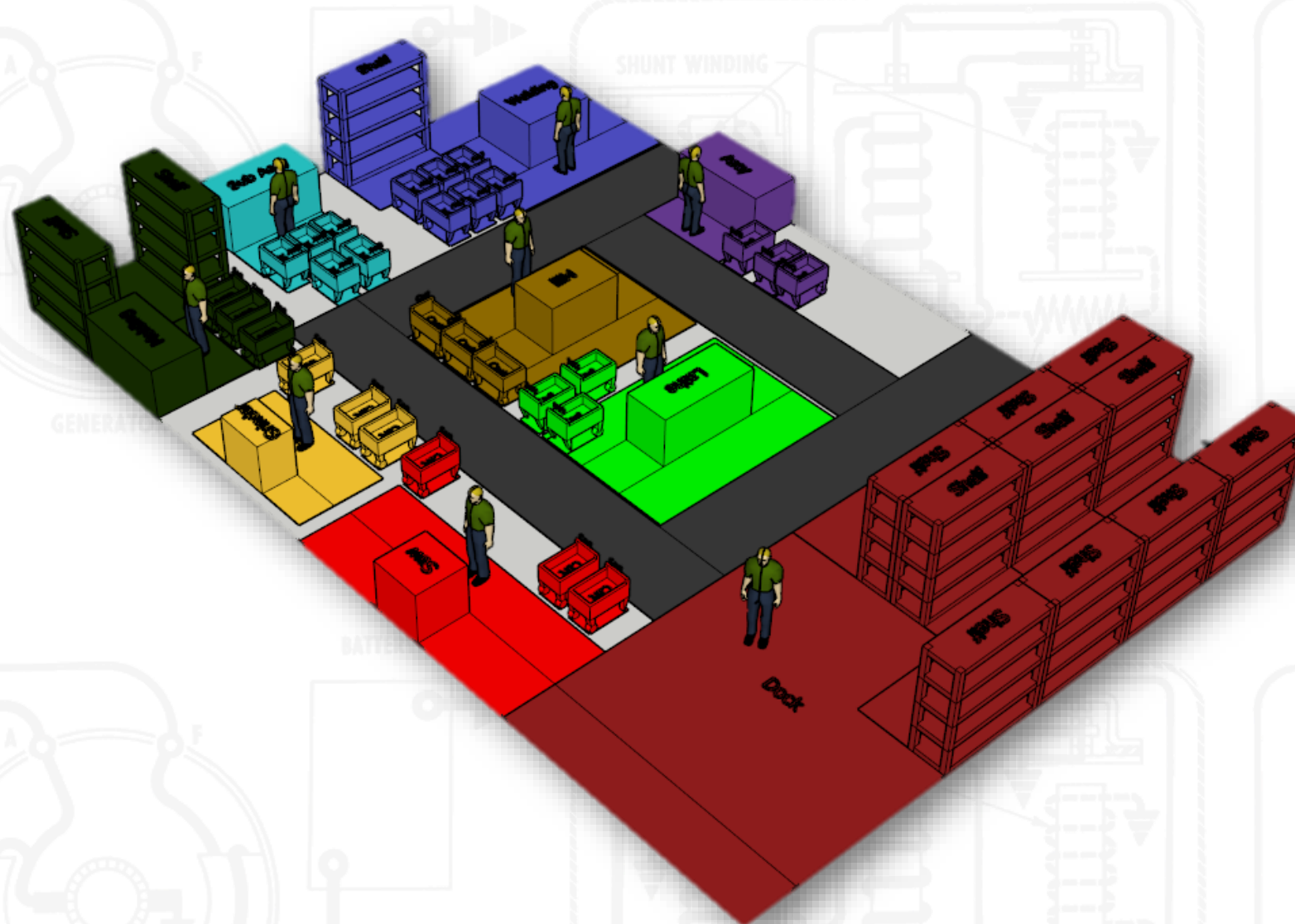
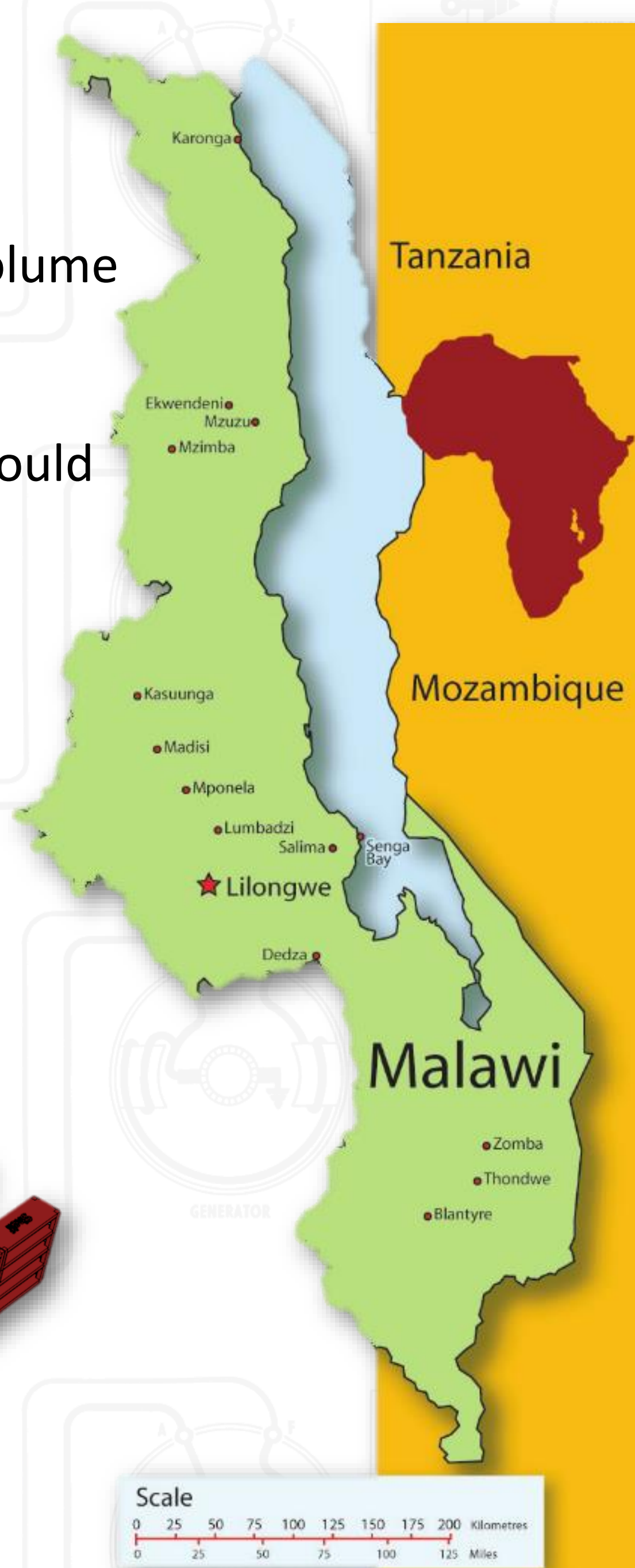

The Manufacturing Facility

- Currently being constructed (above is a temporary facility)
- The new facility will have adequate space as it meets the requirements laid out in the floor plan design.



The Prototype

- The cage style prototype was constructed
- Could mass produce 20 per week
- Generated 44.5 volts

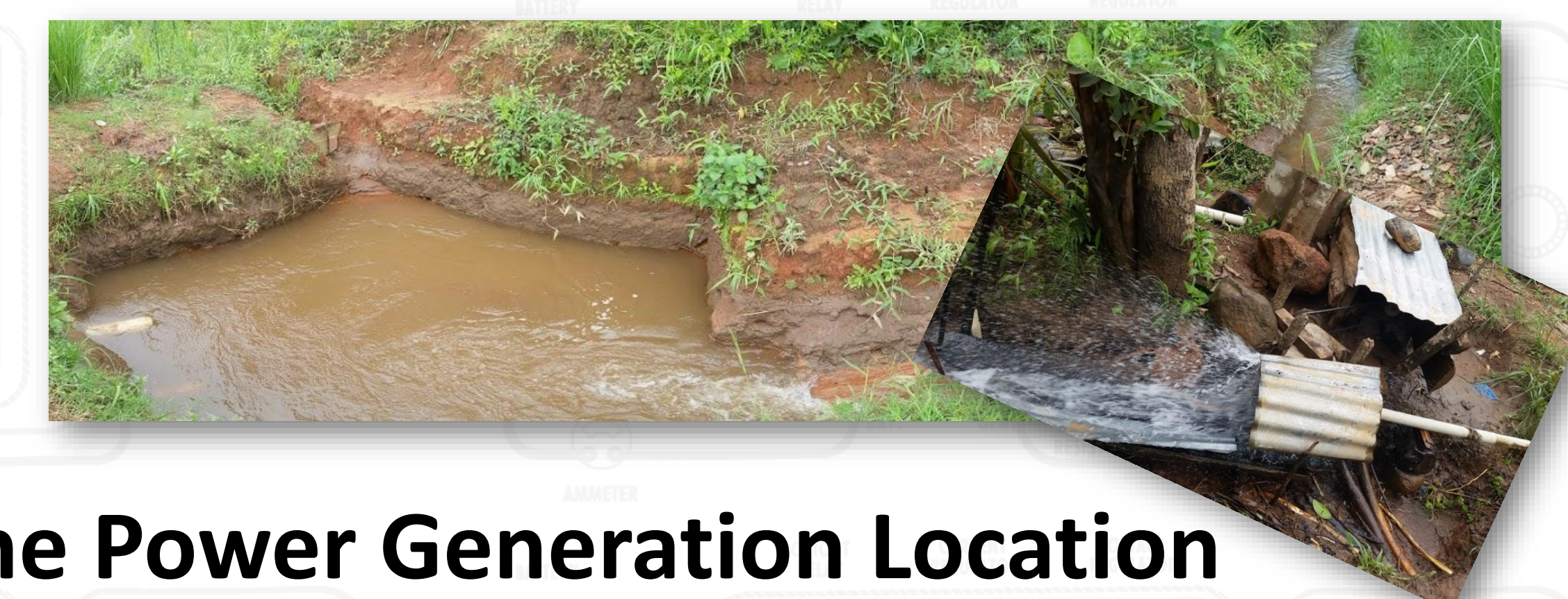
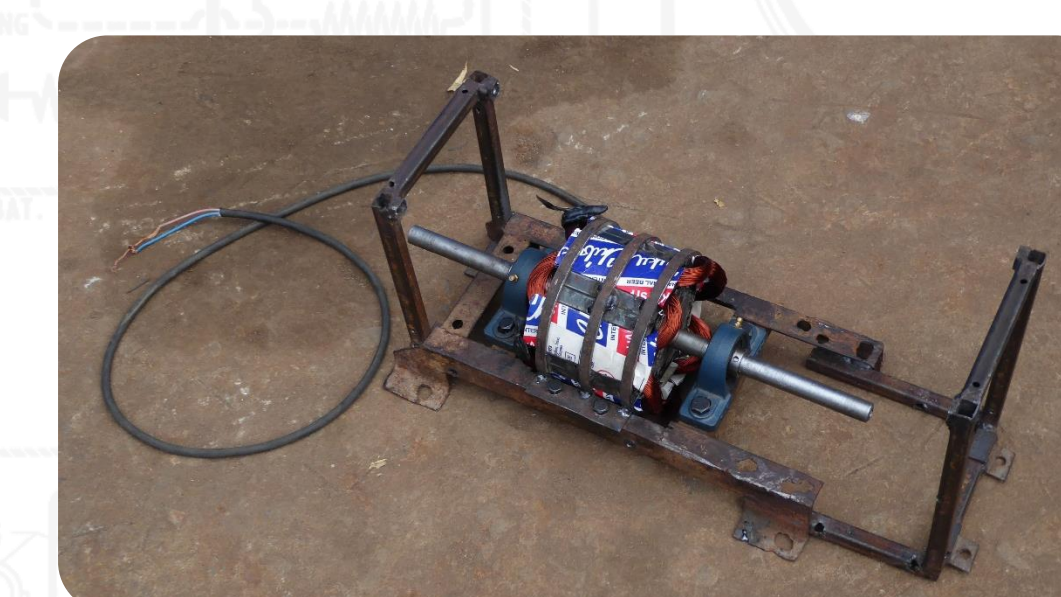

The Power Generation Location

- The current location is difficult to reach (it's in the country)
- A stream is diverted into a holding pool. The water is then directed 25 meters downwards so sufficient pressure head is created.

