

ABSTRACT

LOCHNER, LOUISE T. Integrating Health Education Across the Curriculum.
MS in School Health Education, 1992, 137 pp. (R. Detert)

Seven 5th grade thematic integrated units were developed using a model developed by the 5th grade teacher at Abrams Elementary School, Oconto Falls Area School District. Using an outcome based approach with emphasis on student assessment, the thematic integrated units covered six of the ten health strands suggested in the Wisconsin, A Guide to Curriculum Planning in Health Education. Sixty-eight total objectives were integrated into seven thematic units; 55 objectives spanned the subjects of Art, Education for Employment, Language Arts, Math, Music, Physical Education, Reading, Science and Social Studies and 13 objectives for health education. The 68 objectives were taught in a total of 80 lessons within the seven thematic integrated units. Non-empirical data from observations, health portfolios, journals and class discussions were collected to make statements about the initial success of implementing thematic integrated units. The results of this project demonstrated that health education objectives can be integrated into the curriculum thereby eliminating the need to teach it as an isolated subject area.

INTEGRATING HEALTH EDUCATION ACROSS THE CURRICULUM

A TERMINAL PROJECT PRESENTED

TO

THE GRADUATE FACULTY

UNIVERSITY OF WISCONSIN-LA CROSSE

IN PARTIAL FULFILLMENT

OF THE REQUIREMENTS FOR THE

MASTER OF SCIENCE DEGREE

BY

LOUISE LOCHNER

JULY 1992

WX
97
112

COLLEGE OF HEALTH, PHYSICAL EDUCATION, AND RECREATION
UNIVERSITY OF WISCONSIN - LA CROSSE

TERMINAL PROJECT FINAL APPROVAL FORM

Candidate: Louise T. Lochner

I recommend acceptance of this terminal project in partial fulfillment
of this candidate's requirements for the degree:

Master of Science School Health Education

The candidate has successfully completed his/her terminal project.

R. A. Vetter
Terminal Project Advisor Signature

7-20-92
Date

ACKNOWLEDGEMENTS

I would like to thank several people whose support guided me through this terminal project:

Dr. Richard Detert, my project and academic advisor, for all his instruction and encouragement throughout my graduate experience.

Mr. Chet Bradley, dedicated leader of the Comprehensive Health Education Pilot Project, for including me in his work toward improving health education in our schools.

Ms. Nancy Blair, Cardinal Stritch College, for her expertise in developing the integrated planning tool used in my project.

The University of Wisconsin - La Crosse Health Education Professors; Dr. Leslie Oganowski, Dr. Barbara Pretasky, Dr. Ken Becker and Dr. Jack Jordan, for all their excellent instruction and expertise in the area of health education.

Pilot Project team members, Ms. Cynthia Trettin, Mr. Tom Lutz, Dr. Victor Rossetti, Ms. Cynthia Coley, Mr. K. Jon Makuck, for giving their time to improve our district's health education program, and for the support given to better my education and professional growth.

Fellow Pilot Project classmates, Deb Wood, Cindy Short, Maureen Ulrikson, Barbara Urbanski, Jane Weiser, George Klein, Dale Jonson and Jim Winkels, for friendship, support and leadership throughout our graduate experience.

Rita La Rock, my typist and friend, for her time and hard work preparing this terminal project.

My family, for their love and support.

My husband Mike, for his support, patience, understanding and love throughout my entire graduate experience.

I wish to dedicate this terminal project to my mother, who died four years ago, one who inspired me to teach, encouraged me to succeed, and enlightened me with love. She is "The Wind Beneath My Wings".

Forever Grateful,
Louise

TABLE OF CONTENTS

| | PAGE |
|--------------------------------------|------|
| TITLE PAGE..... | i |
| APPROVAL FORM..... | ii |
| ACKNOWLEDGEMENTS AND DEDICATION..... | iii |
| TABLE OF CONTENTS..... | iv |
| LIST OF TABLES..... | v |
| LIST OF APPENDICES..... | vi |
| SECTION | |
| I. INTRODUCTION..... | 1 |
| Goal..... | 2 |
| Rationale..... | 3 |
| Definition of terms..... | 4 |
| Review of Related Literature..... | 5 |
| II. METHODS..... | 11 |
| Timeline..... | 14 |
| III. OUTCOMES AND OBSTACLES..... | 17 |
| Primary Outcomes..... | 17 |
| Secondary Outcomes..... | 19 |
| IV. DISCUSSION AND CONCLUSIONS..... | 25 |
| REFERENCES..... | 28 |
| APPENDICES..... | 30 |

LIST OF TABLES

| TABLE | PAGE |
|--|------|
| 1. Number of Subject Specific Objectives for Seven Fifth Grade Units at Abrams Elementary School Using Thematic Integration..... | 18 |
| 2. Number of 30 - 60 minute Lessons Taught in Each of the Seven Integrated Units in the Fifth Grade at Abrams Elementary School..... | 19 |

APPENDICES

| APPENDIX | PAGE |
|---|------|
| A Integrated Planning Tool..... | 30 |
| B Thematic Webbing Activity Sheet..... | 33 |
| C Thematic Integrated Unit "Bones"..... | 35 |
| D Health Education Strands and Objectives..... | 51 |
| E Thematic Integration "Cherish the World"..... | 54 |
| F Thematic Integration "Memories"..... | 84 |
| G Thematic Integration "Self-Concept"..... | 91 |
| H Thematic Integration "The Haunted Igloo"..... | 99 |
| I Thematic Integration "Happiness"..... | 112 |
| J Thematic Integration "Risky Behaviors"..... | 123 |

SECTION I

INTRODUCTION

The state of Wisconsin is involved in a five year pilot project titled "Wisconsin Comprehensive Elementary Level Health Education: Toward an Integrated Team Approach." In order to have an understanding of the goals in the pilot project, one needs to know that a comprehensive school health program is an organized set of policies, procedures, and activities designed to protect and promote the health and well-being of students and staff which has traditionally included health services, healthful school environment, and health education (Report of the 1990 Joint committee on Health Education Terminology). Included in the goals of the pilot project is a commitment to improve comprehensive school health instruction which refers to the development, delivery and evaluation of a planned curriculum, pre-school through grade 12. Within the curriculum, goals, objectives, content sequence and specific classroom lessons are developed, but not limited to the ten health areas suggested in the Wisconsin, A Guide To Curriculum Planning In Health Education.

Leaders of the pilot project are Mr. Chet Bradley, Health Education Consultant of the Wisconsin Department of Public Instruction, Dr. Richard Detert, Health Education Department at the University of Wisconsin La Crosse, and Ms. Nancy Blair, Department of Education, Cardinal Stritch College. Together they cooperatively developed an extensive five year plan for improving a Comprehensive School Health

Program in ten Wisconsin elementary schools.

Schools from across the state applied for the grant associated with the project. After extensive screening, ten schools were selected to carry out the project for five years. One team dropped from the project at the beginning of the first summer session leaving nine teams to complete the project. An elementary teacher from each school, the building principal, and two other key staff comprised a building leadership team. The team will devote five years toward improving comprehensive school health education in each of the selected school districts.

The elementary teacher completed a master's degree in School Health Education at the University of Wisconsin-La Crosse in three years. Included in that three years was a two week, graduate level leadership course of study. There, teams worked on team leadership skills and wrote action plans to carry out activities in health instruction, professional staff development, and school culture for the up-coming year.

I am one of the nine elementary teachers in the project who has worked three years completing a master's degree in School Health Education at the University of Wisconsin-La Crosse. This terminal project is one result of the vision for the future of comprehensive elementary health instruction as a thematic integrated approach across the curriculum.

Goal

The goal of this terminal project was to develop an integrated health education curriculum with units covering six of the ten health

strands at the fifth grade level in Abrams Elementary School. Specific focused outcomes, assessment, and activities reflected how health education objectives were integrated into existing content areas of the district's curriculae.

Rationale

Health education can no longer be taught as isolated segments of the required curriculum. Health education needs to be an integral part of the total curriculum. "If good health is basic to life, then health education is a basic course within the total curriculum" (Purdy & Tritsh, 1985).

However, each year more responsibility is placed upon elementary teachers. In addition to planning lessons, teachers have recess duty, M-team responsibilities, Department of Public Instruction requests, and committee assignments. Because of the lack of time and adequate professional preparation of elementary teachers to teach health, health instruction often takes a back seat to other subjects. By integrating health objectives into existing curricular areas, elementary teachers can successfully implement a comprehensive health education program without being overly burdened with another content area.

In addition to alleviating problems with class time, providing elementary teachers with "hands on" integrated lessons through inservice training will better assist teachers to integrate health objectives into daily curricular topics. Several studies have suggested that teacher inservice training has notable influence on health curriculum implementation (National School Board Association, 1991). Further, "Well trained teachers using effective and appropriate instruction have

a greater chance of succeeding in achieving their health education objectives" (National School Board Association, 1991). The result of well prepared elementary teachers will be increased awareness of the need for teaching health as primary prevention; thus influencing children to develop positive healthy lifestyles.

Definition of Terms

For the purpose of this project, several terms need clarification.

They are:

Integration - A curriculum organization which cuts across subject matter lines to focus upon comprehensive life problems or broad areas of study that bring together the various segments of the curriculum into meaningful association (Good, 1973).

Various Approaches to Integration:

Interdisciplinary - Approaches align contents and concepts from one subject discipline with contents/concepts of another at the same time maintaining the clear boundaries between disciplines (Shoemaker, 1989).

Thematic Integration - Subjects or courses subordinated to some relational theme or supra-idea in which boundaries between subjects become blurred (Shoemaker, 1989).

Holistic Integration - Learning focuses on the whole child--the integration of ones cognitive, physical, affective and spiritual dimension. The goals of holistic movement are generally self-actualization and social involvement (shoemaker, 1989).

Integrative Mind/Brain Functions - Using the four brain functions: the thinking function, the feeling or emotional function, the physical/sensing function and the intuitive function (Clark, 1986).

Review of Related Literature

The purpose of this review was to examine areas of literature related to integration. Although not a great deal was found on integrating health education into the curriculum, attempts of integration ideas were cited in isolated journal articles. Several articles relative to integrative education provided relevancy to the process of curriculum integration.

Shoemaker (1989) clarified the significance of integrative education from human brain and learning research and the problems an overcrowded and fragmented curriculum has on learning, thus establishing reasons for a needed change in curriculum. Specifically cited was classroom teachers and administrators nationwide complaining of too much to teach and too little time to teach it. Vann (1988) summarized this idea by stating, "The elementary cup runneth over, and no one at the state level appears to recognize either the magnitude of the runoff or the disillusionment of those who must mop up the spillover" (p.10).

Benjamin (1989) supported the case for a new curriculum by indicating that curriculae should be centered around core ideas, be thematic, integrate many disciplines, and reflect different levels of complexity. Hart (1983) suggested that the findings related to the brain have direct implication for schools and organization of the curriculum. She stated, "The curriculum should avoid fragmentation and instead emphasize patterns to unify knowledge and promote the transfer of learning" (p.11). Hart believed that a smorgasbord of ideas can accommodate a wide range of learning styles and allow teachers greater

recognition of individual differences.

In 1989, Shoemaker stated that curricularists are concerned about the fragmentation of the current curriculum and compartmentalization of knowledge with its accompanying specialization and frequent irrelevance to real world problems. Piele (1989) and Good (1973) supported this idea by recommending that students see how pieces of the curriculum connect, and that cutting across subject matter lines is a more effective way of bringing together segments of the curriculum into meaningful association. Piele (1989) wrote, "When students master each piece of the curriculum in isolation from the others they are not likely to see how the pieces connect" (p.14).

An article by Jacobs in 1991 titled, "The Integrated Curriculum" stressed that interdisciplinary/integrated curriculae addressed the problems of fragmented schedules which shatter curriculae into isolated pieces of knowledge. Jacobs (1990) stated "Implementing interdisciplinary curriculum units helps children acquire targeted concepts and skills of various disciplines more effectively" (p.22). Vars, an educator who supported those findings, believes that students need to make sense out of what they are learning. Integrated units help students relate to the outside world by relating situations and individually processing connections through problem-solving strategies. He wrote, "Educators once more are seeking ways to help students make sense out of the multitude of life's experiences and the bits and pieces of knowledge being taught in the typical splintered, over-departmentalized school curriculum" (1991, p.14). He supported a student-centered integrative curriculum in which teachers and students

develop units of study, but stressed that the study must be worthwhile, doable, and appropriate for the students' level of maturity.

In retrospect, the support for integrative approaches were reviewed as effective ways of addressing issues related to overcrowding and fragmentation of current educational curriculae. Integrative programs have the potential for providing a more effective approach to instruction. Shoemaker (1989) concluded by saying, "Integrative approaches facilitate the implementation of educational practices that will more adequately prepare students for life in the twenty-first century" (p.17).

Many educators are looking for ways in which to reform their curriculae, and there are several aspects to consider when making the change. For example, future education must focus on all aspects of learning. In addition, new curriculae must allow for a variety of different learning styles. Through an integrated curriculum, new assessment procedures are applied. Teachers can evaluate differently by using role playing, predicting or creating projects. Cooperative learning can take place, and children's literature is used more readily. Crowell noted in 1989 that, "Learning is physiological experience and much more than just a mental exercise" (p.11). Smith (1986) supported this idea by stating that the brain is always learning and that we learn exactly what is demonstrated by the people around us. He can be quoted by saying, "Schools must stop trying to teach through pointless drills, activities, and tests" (p.11).

There is a drive among practitioners to define standards through outcome-based education. Spady and Marshall (1991) called for

thoughtful definitions of outcomes we really want for students, most of which cross interdisciplinary lines. Integrating the curriculum was the focus of the October, 1991 issue of The Educational Leadership Journal. From the depth and breadth of the journal articles it was evident that many educators are coming to similar conclusions. Teachers in forward-looking schools are joining multidisciplinary teams, tackling the tough question about what sorts of things their students will need to be able to do to live satisfying, productive lives. Brandt (1991) concluded by stating that "More and more schools are making an effort to forge a more integrated curriculum. Those developing performance standards will do well to follow their lead" (p.3).

When designing an integrated curriculum one must look for natural connections between required subject areas. Jacobs in 1991 stated, "Keep in mind that not all subject areas need to be included in a multidisciplinary unit. In fact, attempts to do so can yield some strained connections" (p. 23). It is suggested that teachers map out curriculum choices on a monthly academic calendar to identify potential areas for unit development rather than inserting something new to an already packed year. Educators should talk and plan, to make sense and to make connections in the curriculum. As Jacob stated, "Integrating knowledge is basic to education" (1991, p. 23).

It is evident that more and more educators are interested in interdisciplinary curriculae. But as Jacobs (1991) noted, "The biggest obstacle to interdisciplinary curriculum planning is that people try to do too much at once. What they need to look for are some, not all, natural overlaps between subjects" (p.25). Jacob advocated that to

develop an integrated curriculum, a district needs an action plan. She developed a four phase plan and recommended that it be accomplished over a three-year period. The four phases are:

Phase I: Conducting Action Research. During this phase, staff members concentrate on learning more about their current curriculum as well as about best practices from the field.

Phase II: Developing a Proposal. The purpose of the proposal is to assess potential areas for multidisciplinary or interdisciplinary units.

Phase III: Implementing and Monitoring the Pilot. Actually doing lessons and units during the second year. Most units run two-to-six weeks with group members who regularly meet to assess the impact of the units.

Phase IV: Adopting the Program. During the third year of the plan staff members are prepared to make revisions to the program based on the data collected in the pilot phase, and then adopt it as a permanent part of the curriculum. Jacob noted that "by following an action plan based on solid research, a powerful pilot, and thoughtful monitoring, district planners can guide a unit through successful program adoption" (1991, p. 27).

National testing standards have also been a concern to some educators. With so much emphasis on test scores, educators worry that integrative curricula do not cover all the basic skills necessary. Vars responded by stating, "The evolving concept of core curriculum was tested in the famous Eight Year Study of the Progressive Education Association. Curriculum studies done in 1984 by the National Association for Core Curriculum found that more than 80 normative or

comparative studies have illustrated the effectiveness of integrative programs. In nearly every instance, students in various types of integrative/interdisciplinary programs have performed as well or better on standardized achievement tests than students enrolled in the usual separate subjects" (1991, p.11).

In conclusion, when designing an integrated curriculum educators must take into account subject matter, materials, and assessment. The new curriculum must start small and gradually progress as teachers become more comfortable, but most importantly educators must teach appropriate, meaningful subject matter. As Vars (1991) summarized, "The continuing challenge is to design curriculae that simultaneously take into account solid subject matter, the needs of the learner, and society's problems" (p.15).

SECTION II

METHODS

Planning a Thematic Integrated Unit

Presently there is no established model available which allows elementary teachers to integrate themes or subject areas which have a focus on outcome based education. To facilitate the integration concept as outlined in this project, an integrated planning tool prototype developed by Nancy Blair, Cardinal Stritch College, (Appendix A) and a thematic webbing activities form developed by Teacher Created Materials Incorporated (Appendix B) was used. This prototype differs from the way in which most curriculum integration occurs. In this prototype, the focus is on outcome and assessment rather than on a series of learning activities. In each content area the activities, related to a central theme, are written in a webbing pattern to facilitate the outcome and to prepare the students for assessment. Several steps were undertaken to complete this project using this new draft prototype. For clarity the Bones unit will be used as the example when describing this step.

Step One

Identify a core theme; e.g. "Bones" (Appendix C)

Step Two

Select a health strand and specific objective at the 5th grade level using A Guide to Curricular Planning in Health Education in Wisconsin (Appendix D). Personal health, family life, mental-emotional,

environmental health, substance use and abuse and HIV/AIDS, were the strands used in this project. Suggested objectives listed within each health strand that apply to the themes were chosen for use.

Step Three

Identify specific learner outcomes from which each content area can contribute. Two outcomes of the Bones Unit were (1) to demonstrate an understanding of the major parts of the skeletal system and (2) to identify the interdependence of the skeletal system (Appendix C).

Step Four

Develop assessment procedures to evaluate success of learner outcomes which transcends just testing. Procedures developed include what learners can share orally, write, predict etc. which identifies to the teacher the achieved outcomes. In the Bones unit (Appendix C), for example, learners were asked to identify the skeletal system as interdependent. Assessment included writing a prose in Language Arts titled "My Life Without Bones." The teacher evaluated the writing by determining if the learner could make specific predictions about what would happen to the body without the skeletal system.

Step Five

Identify other content areas and specific objectives which contribute to the outcome using individual district curriculae. Specific objectives were identified from teacher curricular guides in each content area where knowledge or skills can be developed. All objectives were then connected to the core theme. For example, a specific content area is Math. At the fifth grade level a specific objective is that all students will measure to the nearest 1/4 inch. In

the Bones Unit, learners were asked to trace one another's bodies, draw the bones, and measure the bones to the nearest $1/2$ ", $1/4$ " and $1/8$ ". Students were then assessed on their ability to do so.

Step Six

Develop specific learning activities in each content area which moves learners toward the theme outcomes. The activities were put in a "web" to illustrate how all the activities are connected to each content specific area without isolating any area in the curriculum; e.g., Math class measured the bones, Language class wrote reports on bones; Music sang "Dry Bones" and played it on the recorder; Science studied the location of the bones in the body; in Reading students learned that story elements are the skeleton of a story; and Art class made papier mache' bones.

By following the six steps to the integrated curriculum above, health objectives were integrated into an existing curriculae, thereby alleviating a specified time slot for health content in the schedule. All activities are outcome based and assessed using a variety of methods.

Using the Thematic Integrated Unit

The first section explained how to set up a thematic unit using the developed prototype. This section will explain how to use the thematic units included in appendix (C - I) of this terminal project.

The units are set up in four parts: (a) outcomes and assessment (b) content objectives (c) webbing activities (d) related materials. Page I consists of the identification of the theme, health strand covered, time needed to complete the unit, the outcome expected, and the

assessment to be used.

Page II are the objectives covered in each content/subject area taken from the district curriculae. (Note: not all subjects are included in each unit. Refer to review of literature page 5 for explanation.)

Page III is the activities page which webs activities to meet all subject objectives into the core theme, and then demonstrates how to integrate the objectives across the curriculum.

Included in Part IV are hand-outs, run-off worksheets or directions to games which reinforce one or more objectives from the activities page.

It is important that each unit focus on the outcome listed from page one. Also, activities for various content/subject areas may reinforce, develop, or review objectives from the curriculum. Specific skills to be introduced such as multiplication of fractions may be taught in an isolated lesson and then later reinforced in a thematic unit. Certain objectives may need pre-requisite introduction; e.g., the process of writing a story needs to be introduced before the actual story is written.

All activities are written in a way that leaves flexibility for teachers to web off other creative ideas in a subject matter or content area of choice.

Timeline

The timeline by which this terminal project was completed was one school year.

The first two chapters of the project were started in early August,

1991 and were added to throughout an 11 month process.

The webbing of activities was the first idea to be added to the appendix, but from further review it was noted that the assessment and evaluation seemed incomplete.

By January 1992, a new outcome based prototype developed by Nancy Blair was introduced, which later became the foundation of each unit in the appendix. The prototype is the integrated planning tool by which health strand, theme, assessment, learner outcome and objectives were introduced. In March 1992, a workshop in Appleton sponsored by Teacher Created Materials, Incorporated titled "Thematic Teaching" introduced me to what became the format for the webbed activities of this terminal project. The format clearly shows how the objectives from other content areas connect by basing all activities around a core theme.

Since the beginning of the school year 1991, the fifth grade class at Abrams Elementary had been involved in a variety of integrated thematic units focusing on health objectives and outcomes. One of the units, "Bones", was team taught with fourth grade teacher, Albert Timper, and sixth grade teacher, Linda Hougas. Through the year Pat Doyle, Chapter I teacher, shared literature related to the units and Administrative Assistant, Cynthia Coley, approved curricular policies which supported this terminal project.

A cooperative teaching night class occupied the first three months of school with group skills taken back and implemented into the classroom. Through the year, cooperative learning was practiced and developed within the fifth grade classroom. Cooperative learning activities were then included in the project as part of some activities.

Many journal articles written on thematic teaching, whole language and integration were reviewed through the months. An influx of articles and references helped develop the concept, the origin, and the validity of thematic education.

Each creative lesson from fellow teachers, text books, reference books, or from original creativity were noted as potential activities for the webbing part of the prototype. Only the best and most successful thematic integrated units were compiled into the prototype for this terminal project.

It was an experimental year that proved to be challenging yet rewarding. The plan is to continue developing the thematic unit prototype, to assess the outcome of the curriculae, and to inservice teachers on the development and implementation of thematic instruction.

SECTION III

OUTCOMES AND OBSTACLES

Introduction

The goal of this terminal project was to develop an integrated health education curriculum with units covering six of the ten health strands at the fifth grade level (Appendix D). The six health strands integrated in the units were, mental/emotional health, substance use and abuse, personal health, family life and HIV/AIDS. (Although HIV/AIDS is considered the 11th strand (Appendix D), objectives of that strand were integrated into the mental/emotional strand on risk behaviors).

The units developed were centered around a core theme with lessons covering specific objectives of subject areas integrated into each unit. From the development and implementation of the seven units, two types of findings, primary outcomes and secondary outcomes, were noted.

Primary Outcomes

Overall, 55 subject specific objectives within the seven thematic units were developed and implemented. An additional 13 health objectives were taught as part of these seven units bringing the total number of objectives to 68 (see Table 1). The number of health education objectives was the largest number of subject specific objectives implemented followed closely by language arts, reading, and math. The least amount of objectives covered were in the area of music and physical education. Typically, these subjects are taught by a specialist in that department and reinforced by the classroom teacher.

Table 1. Number of Subject Specific Objectives for Seven Fifth Grade Units at Abrams Elementary School Using Thematic Integration.

| Subject | Objectives |
|--------------------------|------------|
| Art | 5 |
| Education for Employment | 2 |
| Health Education | 13 |
| Language Arts | 12 |
| Math | 10 |
| Music | 2 |
| Physical Education | 1 |
| Reading | 11 |
| Science | 4 |
| Social Studies | 8 |

Each of the 68 subject specific objectives were taught through thematic lessons in specific subject areas. A total of 80 lessons were taught to cover the 68 specific objectives (see Table 2). The lessons consisted of an approximate thirty-sixty minute time span within a 2-4 week unit. Within each 2-4 week thematic unit, six to fifteen 30-60 minute lessons were taught. Following the lessons an assessment procedure for evaluation was given, followed by a culminating activity for reinforcement (see Appendix B for example of culminating activity).

Table 2. Number of 30-60 minute lessons taught in each of the seven integrated units in the 5th grade at Abrams Elementary School.

| <u>Thematic Unit Title</u> | <u>30-60 Minute Lessons Taught</u> | <u>Approximate Time Span</u> |
|----------------------------|------------------------------------|------------------------------|
| "Bones" | 12 | 3 Weeks |
| "Cherish the World" | 14 | 2 Weeks |
| "Memories" | 10 | 2 Weeks |
| "Self-Concept" | 6 | 3 Weeks |
| "The Haunted Igloo" | 15 | 4 Weeks |
| "Happiness" | 11 | 4 Weeks |
| "Risky Behaviors" | 12 | 3 Weeks |

Secondary Outcomes

Although no attempt was made to empirically discover the effectiveness of these integrated units for this project, class observations, health portfolios, journals, and class discussions were used to glimpse student learning and teacher satisfaction. Below is a list of the perceived benefits of using integrated thematic units.

Increased Student Achievement of Outcomes

It was observed through evaluation procedures of individual lessons, and subsequently assigned grades, that all 22 students had achieved the outcomes specified for each thematic unit. This reflects an increase in student achievement from previous years when tests were used as the primary mode of evaluation.

Enhanced Motivation and Interest

Because of the increased achievement of outcomes, grades improved. Thus, students appeared more motivated to continue thematic integrated units. The improved motivation and interest level was apparent through student questioning and commenting on how much they enjoyed a particular unit. They also brought materials from home relating to a particular unit or theme. In addition, higher interest added to a continued connectedness to the outside world. Students would compare things they had learned in class and relate it to events taking place in their lives outside the classroom, e.g., current events on television, sibling decisions, or family situations.

Increased Oral Expression

During each thematic integrated unit, students were able to express themselves in some way by relating a personal experience, sharing a current event related to the unit or sharing a story written for class, thus allowing time for each individual to share orally with the others in the class.

Enhanced Classroom Climate and Cohesiveness

As a result of the various methods of teaching, such as, cooperative learning, group energizers and sharing sessions, a more cohesive classroom climate was observed. Students were encouraged to become involved with one another by sharing their health portfolios, their talents and to express themselves without fear of rejection. This created a support system where individuals could feel safe and respected. The classroom climate appeared to be a safe place where achievement and support of others were experienced, thus resulting in

individuals feeling better about themselves and their ability to succeed.

Increased Attention to Learning Styles

The development of the seven thematic units required increased attention to how students learned objectives and how they would be evaluated. The activities and assessments were organized in a way to challenge students of different learning styles; i.e., the higher level learner, the abstract learner, the concrete learner, the auditory learner, and the lower ability learner each had opportunities to learn in ways which matched their learning style. In addition, the learning disabled student also had an opportunity to learn and be evaluated in ways most appropriate for them.

Enhanced Enjoyment and Effectiveness of Teaching

In addition to the outcomes previously mentioned, several important aspects of using thematic integrated units proved to increase the effectiveness of teaching. I added various activities such as, cooperative learning, increased use of trade books, "hands on" activities, team teaching with other grade levels, guest speakers, and play-writing. The variety of methods were found to be enjoyable for the students and myself. Because of increased motivation, higher levels of achievement, and enhanced self-esteem, increased effectiveness of the variety of teaching methods was a relevant observation giving merit to thematic integrated teaching.

Obstacles

Through the process of developing the seven thematic, integrated units, I encountered various obstacles. Several changes were undertaken

in the planning of lessons, teaching methods, and scheduling of class time. Below is a summary of the difficulties encountered during this project.

Clear Understanding of all Curriculae With Objectives Required for Their Grade Level

Because thematic units do not follow a text book page by page, it was important to use all subject curriculae to insure required objectives were covered in each content area. Time was spent studying the curriculae and comparing the objectives to fit into the thematic unit.

Materials Used From A Variety of Resources

Developing these units required constant collecting of resources, materials, and activity pages that related to the theme being developed. Therefore, I needed to create a filing system where all gathered materials and resources were organized in an easily accessible manner.

Experimentation of Teaching Techniques When Implementing a Thematic Integrated Unit

I allowed for change in teaching techniques, flexibility and risk taking, by using more cooperative learning methods, non-test assessment procedures, and peer teaching. There was more interaction among groups which caused the noise level in the classroom to be higher with flexibility of activities and time spend on the activities. Subjects cut across boundary time lines which caused sporadic time scheduling of classes. Peer teaching allowed more student interaction and higher level thinking, but with less direct teacher interaction. Groups had to work through problems with me as an observer rather than the facilitator.

Grading Became More Difficult

I included a variety of teaching methods and activities and developed assessment procedures to include all learning styles, therefore my grading system had to focus on the outcome achieved by each child compared with their ability level. Each teacher needs to decide on a grading system with which they are comfortable. It is important to focus on the outcome matched with the ability of each learner, rather than on a percentage or normative chart.

Extra Planning Time Needed

Although thematic integrated units alleviate the problem of including a scheduled time for health education, it does not alleviate time of preparation for the teacher. It takes extra time to develop each unit, by gathering objectives and materials to be implemented. Planning outcomes and assessment for each unit takes time because they are created, not run-off on a machine from a commercially prepared project. However, once a unit is established and developed, time for planning becomes less of a problem. Activities and objectives are easily related to an established theme, by brainstorming with other teachers and gathering ideas developed from other subject areas.

SECTION IV

DISCUSSION AND CONCLUSIONS

Personal Perspectives

Overall, the time and difficulties encountered were minimal compared to the personal and professional benefits resulting from the development of this project.

The initial goal of this terminal project was to develop an integrated health curriculum covering six of the ten health strands. Through the process of development, further outcomes emanated from the original goal. As a professional educator, the growth I experienced through the process of creating a model for thematic health integration reflected many things. The following is a list of the benefits I encountered through the development of this project.

Personal and Professional Growth

I experienced growth by gaining confidence and competence in my ability to teach. The reward of observing children motivated and ready to learn was essential in reporting the outcomes of this terminal project. An additional reward was the challenge of creating a classroom which impacted on several learning styles and teaching methods while appearing to enhance the self-esteem of my students.

Growth as a Leader in My School District

I am the one teacher in my district who can provide knowledge in integrating elementary health education into the curriculum. The knowledge I gained as a leader in health education has expanded into

areas of staff inservicing, curriculum development, and also opens doors for presentations at state and regional conferences.

Growth in Further Development of Curriculae

At a time of educational reform the outcomes from this terminal project show connections toward the movement of outcome based education and curriculum integration with a strong assessment component. The literature review indicated outcome based education and thematic integration with a focus on health objectives is presently not available. I can envision this project as a framework for further expansion in the area of elementary health education.

Enhanced Ability of Working With Staff and Administration

Through development of this terminal project I gained confidence and ability by sharing my work in curriculum development and inservicing staff and administration on the concept of integration. Through staff inservicing I was able to work with teachers in their classrooms by team teaching lessons, gathering materials, and by providing resources in the area of thematic integration. In order for that to occur, I needed to defend my position on comprehensive health education to the district administration and school board. I gained confidence in my ability to articulate the need for comprehensive health education through explaining the implementation of my thematic integrated health units.

Furthermore, I can envision the findings of this terminal project becoming the framework for further development in elementary health education. I can also envision a future leadership role as a resource person in the area of thematic integrated curriculum and staff development. This vision contains a personal reward for me as it

reflects my philosophies and goals I have in my professional career as an educator. It also reflects my beliefs of the impact comprehensive school health education has on the lives of children and our future society.

Conclusions

Within the context of this project, the following conclusions are noted:

1. It is possible to integrate elementary health education across an existing curriculum by developing thematic integrated units.
2. It is possible to use the model that I developed in this terminal project to implement elementary health education into the curriculum without scheduling a specific time to do so.
3. It is possible to develop outcome based units with assessments as priority over simply connecting a variety of lesson activities together.
4. It is feasible to conclude that changes will take place within the classroom where thematic integrated teaching is used; the teacher by using new techniques and methods, the students by increased achievement, motivation, interest and self-esteem.
5. It is important to develop an understanding of the impact comprehensive school health education has on learning.
6. It is important to experiment with thematic integrated units, to start small and develop further when comfort level increases.
7. It is important to allow flexibility, some risk taking, and extra planning time when implementing thematic integrated units.

8. Thematic integrated units have been observed by students and teachers to increase effectiveness of teaching elementary health education and by adding to the fun and enjoyment of learning.

REFERENCES CITED

- Benjamin, S. (1989). Why Integrative Education? In E.B. Shoemaker. Integrative education: A curriculum for the twenty-first century. (p.13). Oregon School Study Council, 33 (2).
- Brandt, R. (1991). On interdisciplinary curriculum: A conversation with Heidi Hayes Jacobs. Educational Leadership, 41 (2).
- Brandt, R. (1991). The outcomes we want. Educational Leadership, 49 (2).
- Clark, (1986). What is Integrative Education? In E.B. Shoemaker. Integrative education: A curriculum for the twenty-first century. (p.3). Oregon School Study Council, 33 (2).
- Crowell, C. (1989). Why Integrative Education? In E.B. Shoemaker. Integrative education: A curriculum for the twenty-first century. (p.11). Oregon School Study Council, 33 (2).
- Good, A. (1973). What is Integrative Education? In E.B. Shoemaker. Integrative education: A curriculum for the twenty-first century. (p. 9). Oregon School Study Council, 33 (2).
- A Guide to Curriculum Planning in Health Education. (1986).
WI: Department of Public Instruction.
- Hart, L. (1983). Why Integrative Education? In E.B. Shoemaker. Integrative Education: A curriculum for the twenty first century. (p.11). Oregon School Study Council, 33 (2).
- Hofer, K. & Severson, L. (Eds.). (1991). Thematic Units Across the Curriculum. CA: Teacher Created Materials, Incorporated.
- Jacobs, H.H. (1991) Planning for curriculum integration. Educational Leadership. 49 (2).
- Jacobs, H.H. (1991, September). The integrated curriculum. Instructor, pp. 22-23.
- Joint Committee on Health Education Terminology. (1990). Reston,VA.
- Meeks, L. & Heit, P. (Eds.). (1992) Comprehensive school health education: Totally awesome strategies for teaching health. Ohio: Meeks Heit.

- National School Boards Association. (1991). School health: helping children learn. Alexandria, VA: Seamon.
- Piele, P. (1989). What is Integrative Education? E.B. Shoemaker. Integrative education: A curriculum for the twenty-first century. (p. 4). Oregon School Study Council, 33 (2).
- Purdy, C. & Tritsch, L. (1985 April). Why health education? The practical point of view. Delbert Oberteuffer Centennial Symposium. Atlanta, Georgia
- Shoemaker, E. B. (1989). Integrative education: A curriculum for the twenty-first century. Oregon School Study Council, 33 (2).
- Smith, F. (1986). Why Integrative Education? In E.B. Shoemaker. Integrative education: A curriculum for the twenty-first century. (p. 12). Oregon School Study Council, 33 (2).
- Spady & Marshall, (1991). Planning for curriculum integration. Educational Leadership. 43 (2).
- Vann, A. (1988). Why Integrative Education? In E.B. Shoemaker. Integrative education: A curriculum for the twenty-first century. (p. 10). Oregon School Study Council, 33 (2).
- Vars, G.F. (1991). Integrated curriculum in historical perspective. Education Leadership, 49 (2)

APPENDIX A
INTEGRATED PLANNING TOOLS

Integrated Planning Tool

| | | |
|------------------------|--------------|---------------|
| Learner Outcome | | |
| Grade Level: | Time: | Theme: |
| Strand: | | |
| Focus/Outcome: | | |

| |
|-------------------|
| Assessment |
|-------------------|

| |
|------------------------------|
| Content/subject area: |
| Specific Objective: |

| |
|------------------------------|
| Content/subject area: |
| Specific Objective: |

| |
|------------------------------|
| Content/subject area: |
| Specific Objective: |

| |
|------------------------------|
| Content/subject area: |
| Specific Objective: |

Content/subject area:

Specific Objective:

Content/subject area:

Specific Objective:

Content/subject area:

Specific Objective:

Content/subject area:

Specific Objective:

Content/subject area:

Specific Objective:

Content/subject area:

Specific Objective:

APPENDIX B
THEMATIC WEBBING ACTIVITIES

Student Reading

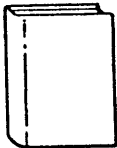

Teacher Read-Alouds (listening)

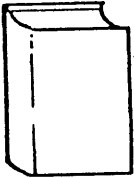

Social Studies



Science



Physical Education



Math - + ÷ × =

Music



Art



Culminating Activity

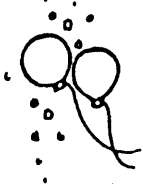

Oral Language (speaking)

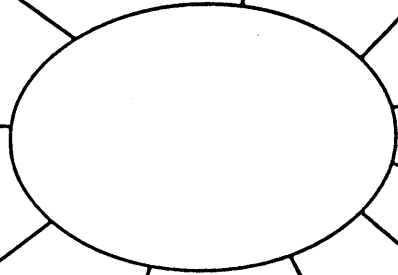

Written Language

APPENDIX C

THEMATIC INTEGRATED UNIT: "BONES"

PERSONAL HEALTH STRAND

Integrated Planning Tool

Learner Outcome

Grade Level: 5

Time: 3 Weeks

Theme: Bones

Strand: Personal Health

Focus/Outcome: To demonstrate an understanding of the major parts of the skeletal system.
To identify the interdependence of the body systems.

Assessment

The learner will assemble and appropriately name the parts of a puzzle of the human skeletal system. (The boney Maroney lesson included in packet.)

The learner will explain the interdependence of the skeletal system by writing a prose titled "My Life Without Bones". (Final Draft assessment paper included in packet.)

Content/subject area:

Reading

Specific Objective:

The learner will identify the sequence of events in a given selection.

The learner will identify elements of a story.

Content/subject area:

Science and Health

Specific Objective:

The learner will identify the major parts of the skeletal system.

Content/subject area:

Math

Specific Objective:

The learner will give the length of an object to the nearest $\frac{1}{8}$ ", $\frac{1}{4}$ ", $\frac{1}{2}$ ".

Content/subject area:

Language

Specific Objective:

The learner will write a three paragraph report based on an outline.

The learner will apply English skills in a creative writing activity.

**Content/subject
area:**

Physical Education

**Specific
Objective:**

The learner will identify types of exercises that strengthen specific bones and muscles on the body.

**Content/subject
area:**

Art

**Specific
Objective:**

The learner will mix a paper mache recipe.

The learner will design bones of the body out of newspaper

**Content/subject
area:**Education for
Employment**Specific
Objective:**

The learner will identify careers associated with the study of the skeletal system.

**Content/subject
area:**

Music

**Specific
Objective:**

The learner will read notes of a song and play it on the recorder.

ACTIVITIES

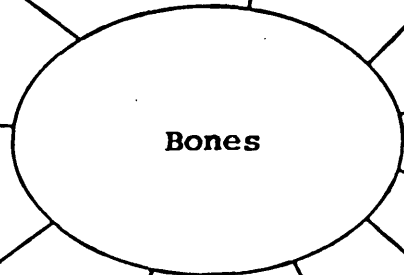

Student Reading

Story Map Hand-Out (Included in Packet)
Select any story, either in the basal or a trade book, study story elements and sequence of events of the selection.



Discuss with students that elements of a story is like the skeletal system. They are the framework of a story like the skeletal system is our body's framework. Neither could survive without it.

Teacher Read-Alouds (listening)

Read: The Skeleton Inside You by Philip Balestrino



Skeleton by Steve Parker

Skeletons! Skeletons! All About Bones by Katy Hall

Education for Employment



- Invite the local chiropractor to speak to the class.
- Study x-rays donated by the x-ray lab at the hospital. Invite an x-ray technician to speak to the class.

Brainstorm in groups all other related careers associated with the study of the skeletal system. Tour the Physical Therapy Dept. at the hospital.

Oral Language (speaking)



The learner will participate in an oral report given on their chosen bone of the skeletal system.

Science and Health



Study the human skeletal system using the diagrams in the packet. Identify the major bones of the body. (Name Your Bones in packet.)

(Could be used as an intro to the study of fossils.)

Physical Education

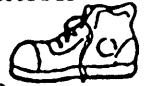

Develop activities related to how the body's shape & size relates to performance in various sports. Create an exercise to strengthen the muscle around each bone of the skeletal system.

Written Language



- Write a three paragraph report on a chosen bone of the skeletal system. Follow the steps to writing a research paper using note cards, outline, proofreading, revising and final copy.
- Write a piece titled "My Life Without Bones"

Culminating Activity

10,000 Pyramid

With bone vocabulary.

(Directions included in packet.)



Music

Sing and play on the recorders "Dry Bones"

Art

In cooperative groups design life size paper mache bones.



Math (Cooperative Learning)

Trace Me Lesson (included in packet)
Measure bones to 1/4", 1/8", and 1/2". Draw and label each bone of the skeletal system. Complete worksheet. How Do You Measure Up?

The Human Skeleton

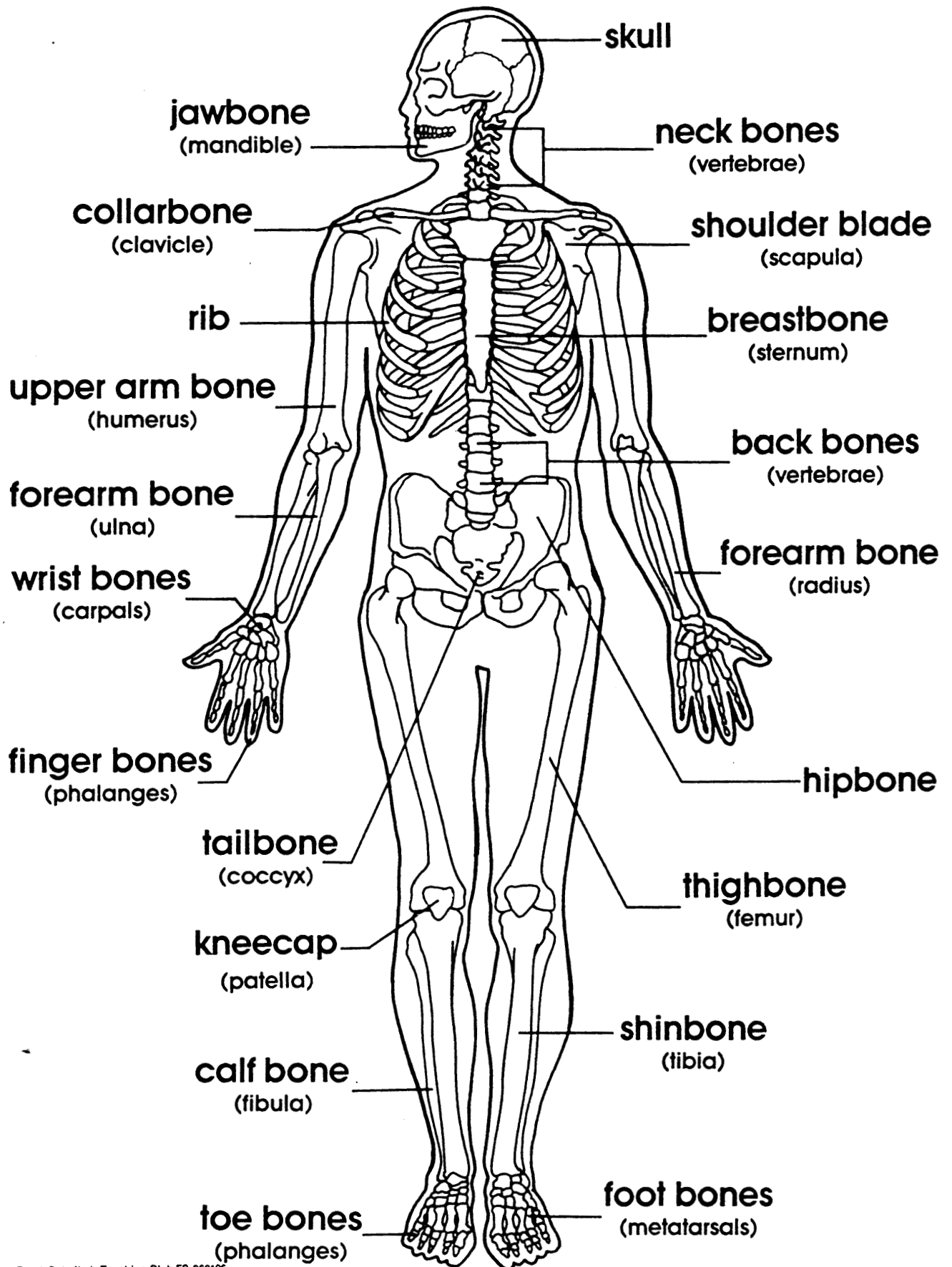

Name Your Bones⁴⁰

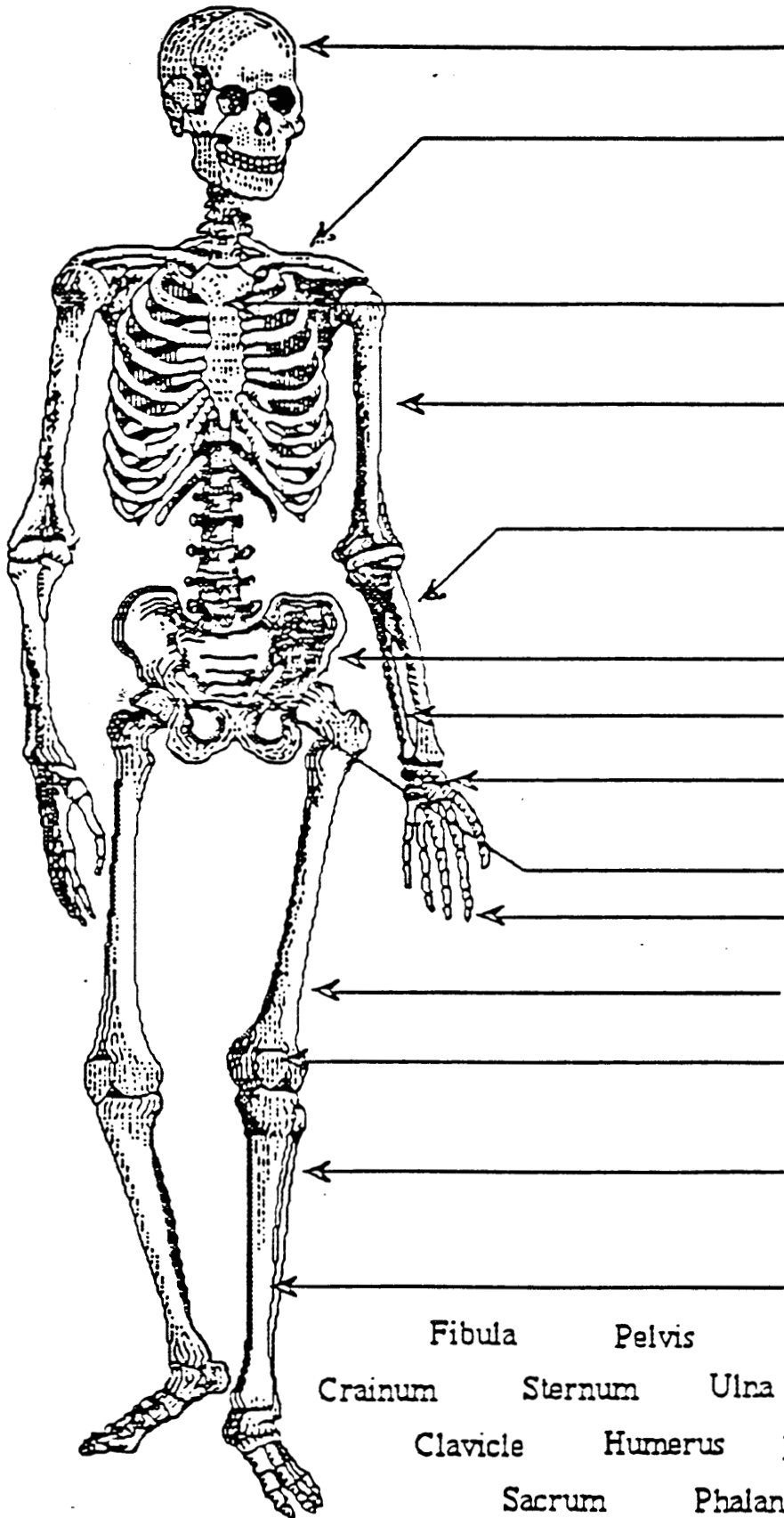

1. _____
2. _____
3. _____
4. _____
5. _____
6. _____
7. _____
8. _____
9. _____
10. _____
11. _____
12. _____
13. _____
14. _____

Fibula Pelvis
 Cranium Sternum Ulna Radius Femur
 Clavicle Humerus Patella Carpals Tibia
 Sacrum Phalanges

BONE Projects from Paper Mache'

MATERIALS:

Glue Mixture (flour & water, consistency of thick gravy)

Newspaper

Torn Paper Strips (1 inch by 6 inches)

Masking Tape

Paints: Tempera, Acrylic or Latex (white)

DIRECTIONS:

You can make any bone in the body. Make a cylinder for a long bone by rolling newspaper into a cylinder. Crush newspaper into balls, use masking tape to secure balls on to ends of cylinder.

Using torn paper strips and glue mixture, place three or four layers of strips over the entire bone. Shape the ends while damp, adding more strips as desired to give the ends of the bone shape.

Dry, and paint. The bones are light weight and make dramatic props for plays, parts of skeletons, decorations, or for Halloween costumes.

*Tape crumpled
paper balls to both
ends of the tube.
Cover with pasted
strips of paper.*

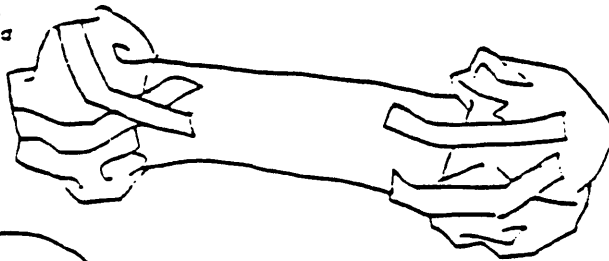

*When dry, paint
with tempera paint.*



Game: 10,000 Pyramid to practice the location of the bones on the body.

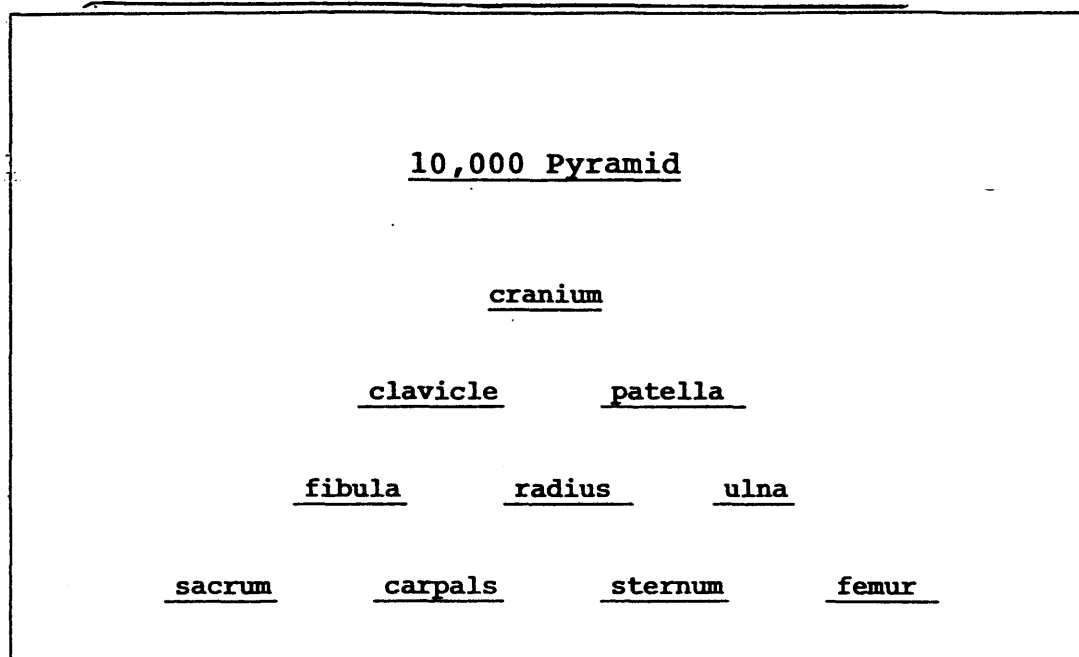

Materials: velcroe, index cards, poster board or wood.

Directions:

1. Write bones on index cards.
2. Velcroe the cards to the board as shown above.
3. In pairs, one student sits with his/her back to the board. The other student sits facing the board.
4. The student facing the board starts in the bottom left hand corner, shows the location of the bone listed on the index card. The other student tries to guess what bone is listed on the card.
5. When the correct bone is guessed, the card gets pulled off the board. The student follows the cards in order. They cannot skip around the board, but they may pass onto the next card and then return back to the card passed.
6. This game is timed. When all students complete the game, check back to see who had the fastest time.
7. Variation: The student facing the board could give the definition of the bone written on the card instead of showing the location on his/her body.

Submitted by:
Louise Lochner

STORY MAP

Title:

Author:

| | |
|----------------|--------------------|
| Setting | Characters: |
| | Place: |
| | Time: |



Problem:

[Empty box for event 1]



[Empty box for event 2]



[Empty box for event 3]



[Empty box for event 4]



**Events
leading
to
Resolution**

Resolution:

Boney Maroney

| | |
|-------------------|--|
| Objective | Students will identify how the major bones inside the body make up the human skeleton. |
| Life Skill | I will eat foods that contain vitamin D to strengthen my bones. |
| Materials | Scissor to cut out bones, glue |
| Motivation | <ol style="list-style-type: none"> 1 Distribute a copy of the bone puzzle below. Have students cut out the bones and place them in the correct way to form the human skeleton. 2 Have students share their puzzles with the class. |
| Evaluation | Have students name the appropriate bones. The bones they will assemble are: skull (head), sternum (breast bone), radius (thick bone above wrist), ulna (thin bone above wrist), humerus (long bone on upper part of arm), clavicle (shoulder bone), femur, (top part of leg), tibia (long bone below knee), fibula (thin, long bone below knee) patella, (knee cap). |

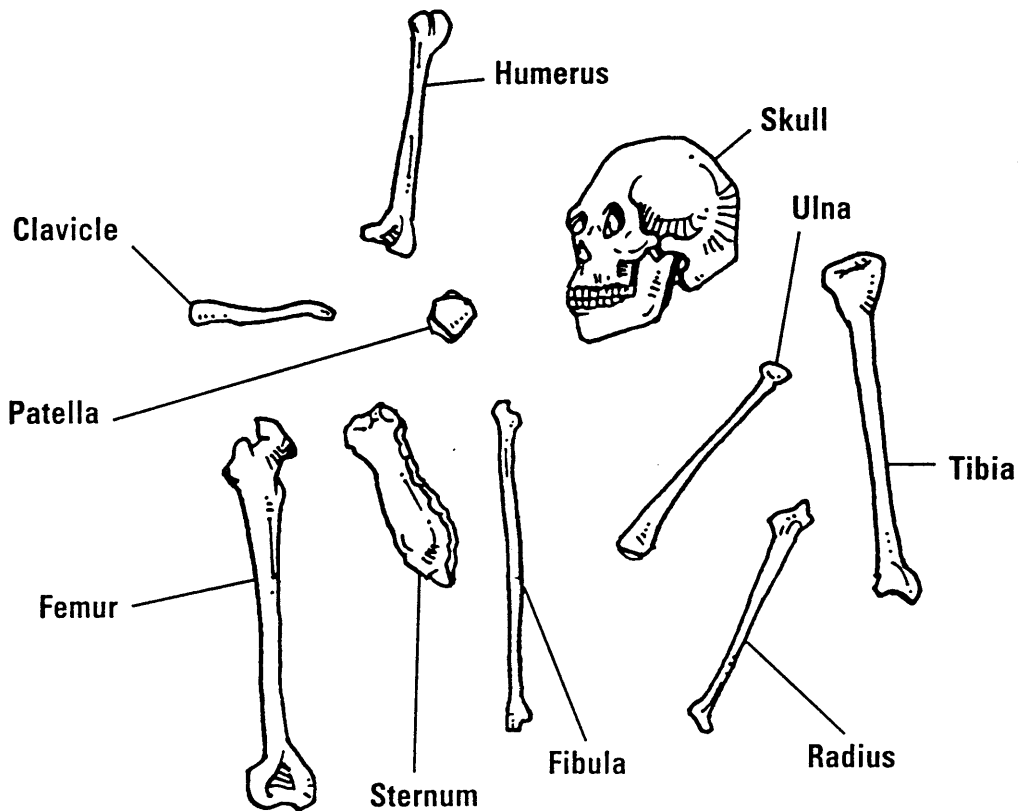

OUTLINE

Title of Article _____

I. _____

A. _____

B. _____

II. _____

A. _____

B. _____

Title of Article _____

I. _____

A. _____

B. _____

C. _____

II. _____

A. _____

B. _____

C. _____

NOTE: One way to write an outline is to follow these steps:

1. List each main idea next to the Roman numerals.
2. Next to the capital letters, list the details that tell about each main idea. Put the details in the order you want to report them.
3. Use a capital letter for the first word in each main idea and detail.
4. Write a title for your outline.

Trace Me

Objective

Students will be able to draw and identify the major bones on a life-size outline of the body.

Life Skill

I will eat foods containing vitamin D to strengthen my bones.

Materials

Large sheets of brown butcher paper that are the size of the human body, white chalk

Motivation

- 1 Tell students you would like them to work with a partner. The students will be paired into groups of two.
- 2 Give each person a sheet of paper. Taking turns, first one person will lie back down on the paper. The partner will outline the person's body on the sheet of paper using a piece of chalk. Then have the students switch and draw the other partner.
- 3 Each person is to take his/her sheet of paper and write his/her name on the bottom in large letters. Students should then fill in the major bones of the body using the chalk. The bones can be colored white. Each student will have a picture of his/her body with the bones drawn. The diagram on the bottom of this page can be used as a guide. Each bone on the body can be labeled as per the picture on this page. You may reproduce the picture on the bottom of this page for students or make an overlay for the class to view.

Evaluation

Select one drawing and cover each of the names of the bones. Have students identify the names of each bone to which you point.

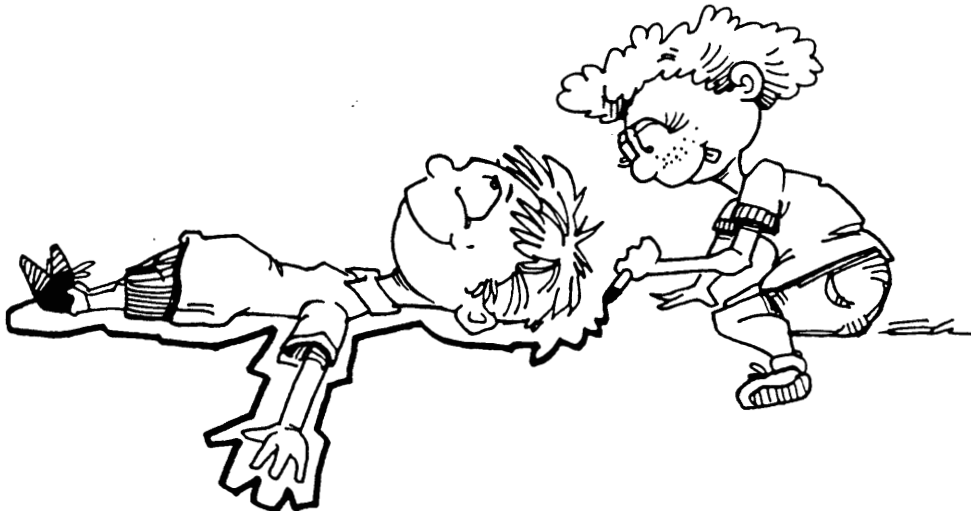

Bones

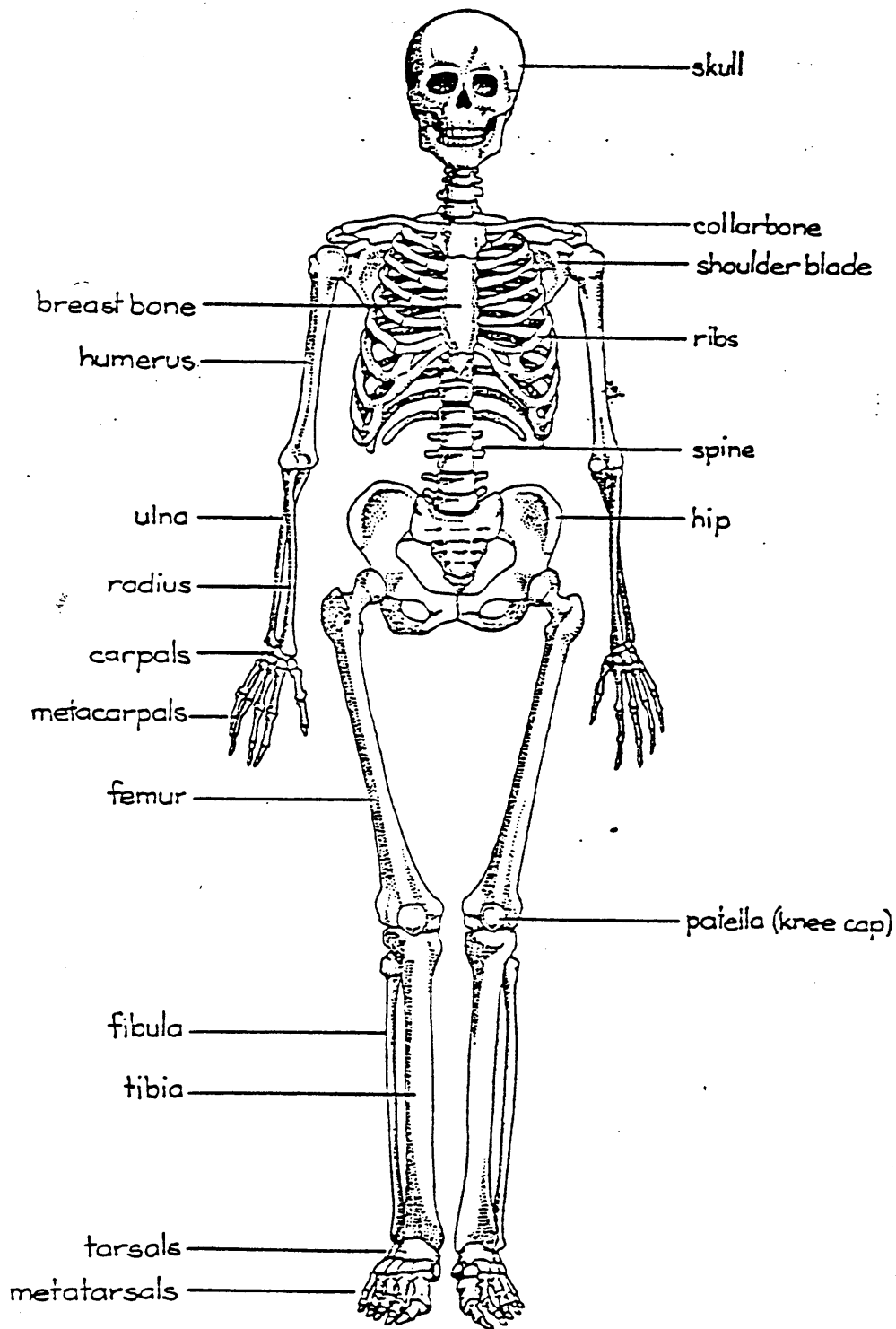

Use the diagram to name
some of the bones you can feel
under your skin.

Name _____ Skill: Making and testing predictions

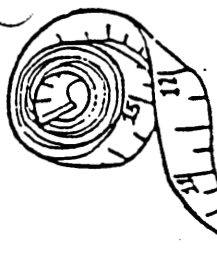

How Do You Measure Up?

Find out by **observing** (looking closely), **predicting** (making a guess based on observation), and **testing** (measuring results). All you need is a measuring tape or ruler.

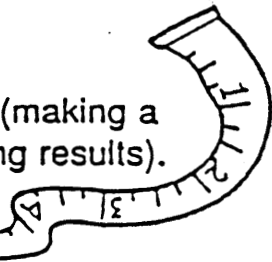

Experiment 1: Sizing Things Up

Complete the table. Compare the two body parts listed in the first column by observing them on yourself or someone else. In the second column state your prediction—which, if either, measurement will be greater. Next, have a friend help you measure each body part. Record the results in the third column. In the last column write whether your prediction was *accurate* or *inaccurate*.

| 1. Body Parts to Compare | 2. Predictions | 3. Results | 4. Accuracy |
|--|----------------|------------|-------------|
| a) length of your ear b) distance from the tip of your nose to the tip of your chin | | | |
| a) length of one eyebrow b) width of your mouth at rest | | | |
| a) distance around the widest part of your calf b) distance around your neck | | | |
| a) length of your shin b) length of your thigh | | | |

How did you "measure up" to your predictions? Do you know yourself well, fairly well, or not very well? _____

Experiment 2: Fit to a "T"

Is your height *greater than*, *less than*, or *the same as* the distance from fingertip to fingertip?

Prediction _____

Ask a friend to help you measure in order to test your prediction.

Result _____

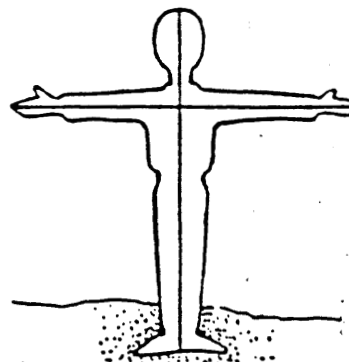

Challenge! Compare the results of your experiments with those of a friend. What similarities and differences do you find?



DIGGING UP SOME FACTS

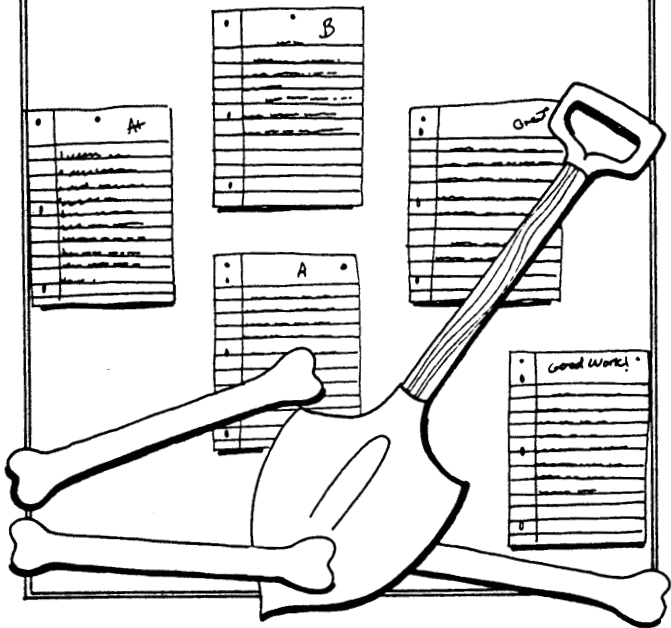

Use this bulletin board to send your students on a search for facts about things that happened long ago. Students could investigate any topic from dinosaurs to fossils. Have each student write a report about his findings and add to the bulletin board.



Use this bulletin board to encourage students to be aware of good manners. Post specifics that you want to encourage and each time a student exhibits one, let him autograph the dinosaur on the board for positive recognition.

AGE-OLD MANNERS

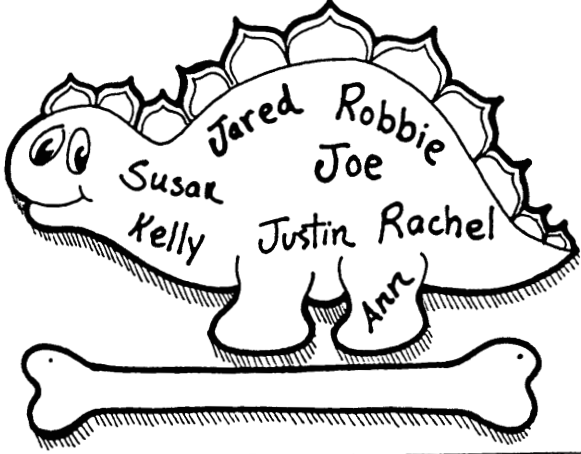

APPENDIX D

FIFTH GRADE HEALTH STRANDS AND OBJECTIVES

FROM A GUIDE TO CURRICULAR PLANNING IN HEALTH EDUCATION

Major Content Strands**Topical References**

Accident Prevention and Safety

- boating safety
- water safety
- choking symptoms

Community Health

- health benefits
- personal and family activities that promote health
- community health issues
- community health specialists

Consumer Health

- * Explain how information contained on a label can be used in selecting health products.
- OTC drugs
- prescription drugs
- quackery versus legitimate health practice

Environmental Health

- * List sources of and methods to deal with solid waste.
- land pollution
- natural resources
- population and land use

Family Life Education

- * List the characteristics that help maintain friendships and compare oneself to this list.
- family impact on each member's development
- death or divorce's impact on the family

Mental and Emotional Health

- group decision making
- peer influence
- interpersonal behaviors
- desirable personal qualities
- risk-taking behavior

Nutrition

- * Identify major sources of key nutrients.
- * Classify foods into groups based on their major nutrient contribution.
- portion size and servings

Nutrition (Cont'd.)

- diet and blood pressure
- fiber
- sample menu evaluation

Personal Health

- * Identify benefits of both aerobic and anaerobic exercise.
- functions of body systems
- interdependency of body systems
- effects of puberty on development

Prevention and Control of Disease

- * Explain the process of communicable disease transmission.
- avoidance of disease
- motivation and health behavior

Substance Use and Abuse

- decision making about drugs
- peer and adult influences
- community impact of drug abuse
- laws

Special Addendum on the AIDS
Virus Infection

- explain that the surest way to prevent AIDS is to avoid the known risk behaviors associated with the spread of the disease

APPENDIX E

THEMATIC INTEGRATED UNIT

THEME: "CHERISH THE WORLD"

ENVIRONMENTAL HEALTH STRAND

Integrated Planning Tool

Learner Outcome

Grade Level: 5 **Time:** 2 Weeks **Theme:** Cherish the World
(Around Earth Day)

Strand: Environmental Health

Focus/Outcome: The learner will list sources of and methods to deal with solid waste.
The learner will describe ways to recycle, reduce and reuse products in our environment.

Assessment

The learner will develop a chart listing products that can be recycled, reduced in use and reused.

The learner will write a poem creating feelings about caring for our environment.

Content/subject area:

Reading

Specific Objective:

The learner will identify the main idea of a selection.

Content/subject area:

Language Arts

Specific Objective:

The learner will understand and identify the different types of poetry.
The learner will identify the steps to writing and performing a skit.

Content/subject area:

Environmental Health

Specific Objective:

The learner will explain what solid waste is and list products in our environment that cause pollution. The learner will identify ways to help our environment.

Content/subject area:

Science

Specific Objective:

The student will participate in Bottle Biology experiments and explore many areas of life science leading to a better understanding of the ecosystem.

**Content/subject
area:**

Math

**Specific
Objective:**

The learner will
analyze data in
line graphs.

**Content/subject
area:**

Art

**Specific
Objective:**

The learner will use
their creative
ability to design
a post card.

**Content/subject
area:**

Social Studies

**Specific
Objective:**

The learner will
read about and
discuss different
multi-cultures in
our world.

**Content/subject
area:**

**Specific
Objective:**

ACTIVITIES

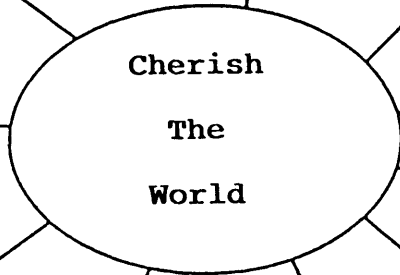

Student Reading

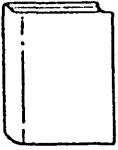

Suggested literature list included in packet

Science text unit on solid waste.

Social Studies text on multi-cultures.

Teacher Read-Alouds (listening)



The First Forest by John Gile

Discuss the main idea of the story.

What can be learned about ourselves from the story?

Discuss

Social Studies



Cherish the World can lead into a multi-cultural thematic unit.

- Indian Study
- Black Americans
- Latin America
- Equal Rights
- Etc.

Oral Language (speaking)

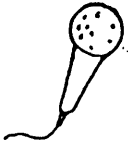

Set up a campaign to Save the Environment

- Make brochures to pass around the school.
- Use the intercom to announce the environmental thought for the day.
- Set up a recycling center at school.

Science



Hands on - Bottle Biology Experiments

(Included in packet)

Physical Education

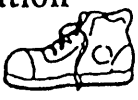

Play the game, Kick the Can

Written Language



Read the poems "The Universe" by Mary Britton Miller
"Nature Is" by Jack Prelutsky

Discuss the twelve types of poetry (included in packet). Write two different poems on saving or caring about the environment.

Drama: Create a skit that teaches the audience how to take better care of the world.

Culminating Activity



All School litter pick-up or tree planting.

Come together, join hands and sing together "We Are The World".

Music



Rewrite the song We've Got The Whole World In Our Hands or We Are The World

Art



Create a post card stressing the concern of saving the world.

Math

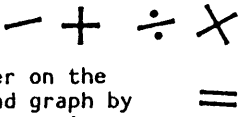

Collect litter on the playground and graph by type. In cooperative groups, set up problem solving situations using recycling littering e.g. 50% of the students litter. What can we do to reduce littering to 0-10%

TWELVE POETIC TECHNIQUES

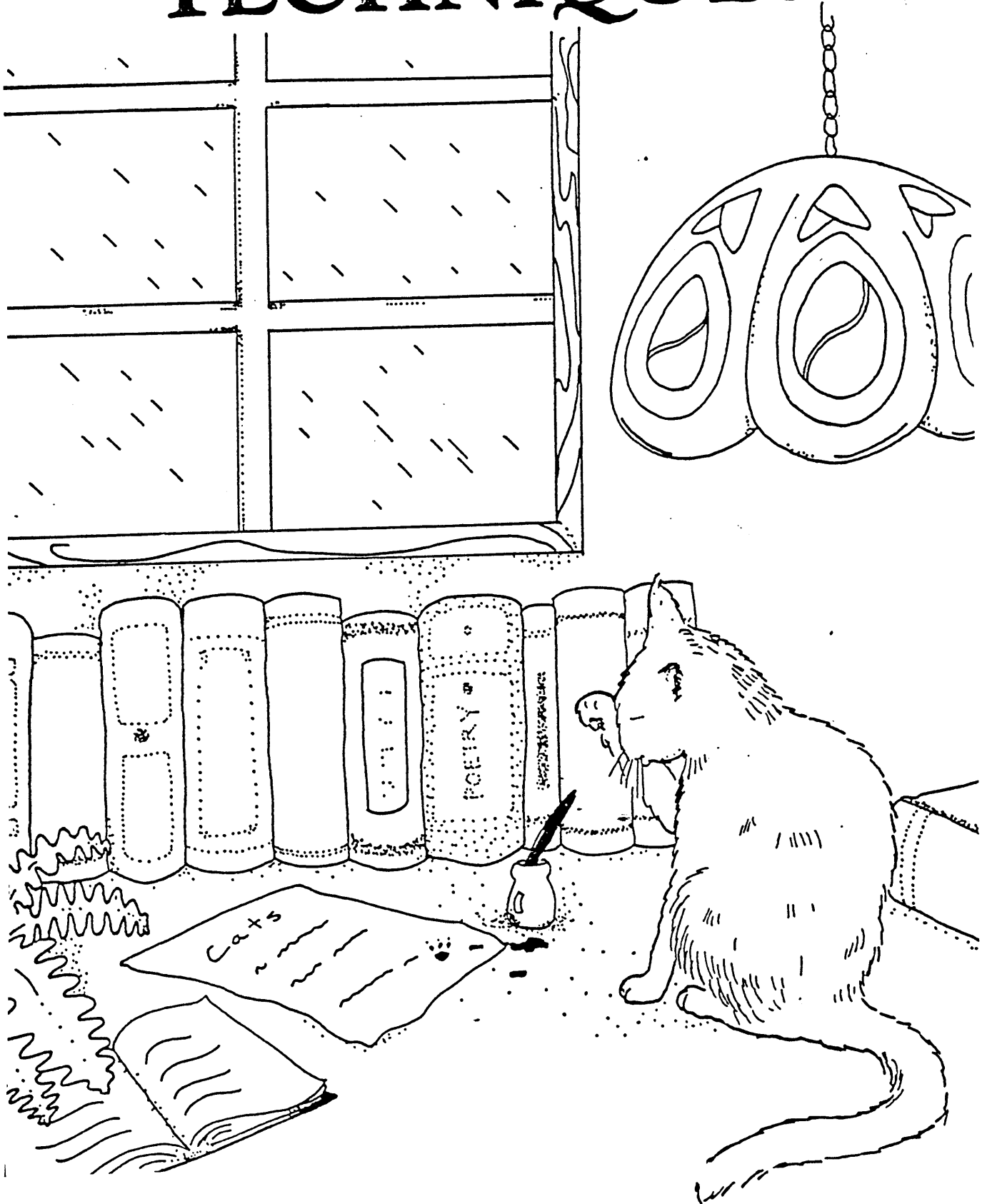

Alliteration

READY

Alliteration is achieved by combining several words with the same initial sound. The words may be written in sentence or verse form. In either case, alliterative energy is contagious, making alliteration a fine activity for beginning writers.

SET

Select a letter of the alphabet. Help the class brainstorm to make a list of words beginning with this letter.

WRITE

Have each student write an alliterative verse about an imaginary person whose name begins with the chosen letter. Instruct the students to continue writing until they cannot think of any more words.

*Barney Buff bought bright blue baseballs.
When Barney Buff batted, his bright blue
baseballs burst! Boo, boo, boo!*

PRESENT

Make a large cutout of the chosen letter for each student. Let the students copy their poems on the letters. Display the letters for all to see.

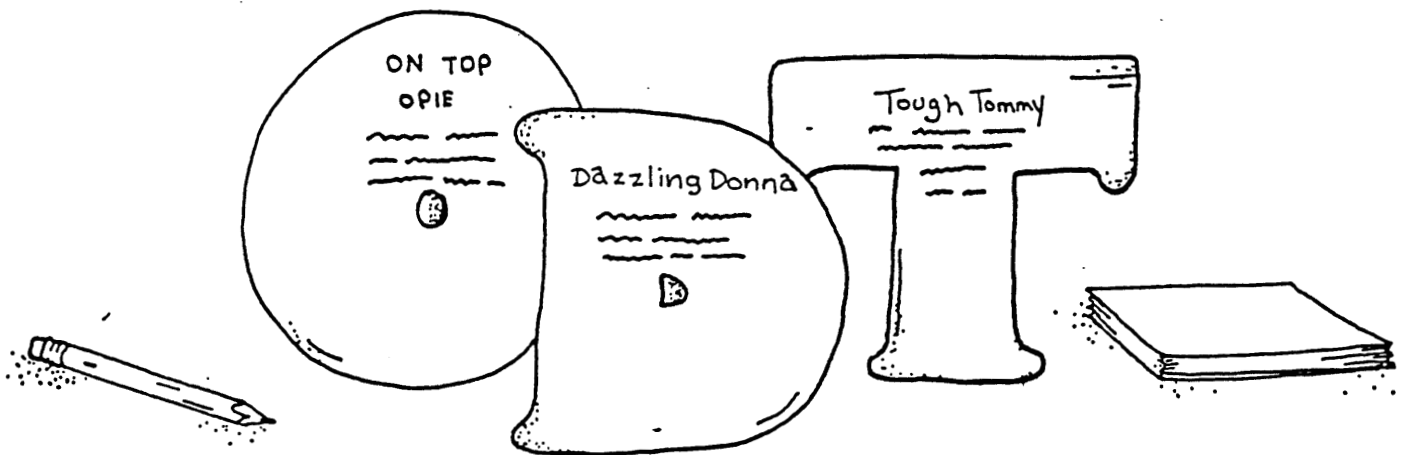

Cinquain

READY

A cinquain is an oriental verse of five lines following the pattern of (1,2,3,4,1) words in each line. A cinquain produces a fragile image or a delicate thought. This activity appears difficult, but the pattern makes it easy . . . even for beginners!

SET

Explore the poem pattern with the class by helping them write several practice poems.

| | | |
|--------|---------------------------|-----------------|
| line 1 | title | (noun) |
| line 2 | description of title | (2 adj.) |
| line 3 | action of title | (3 verbs) |
| line 4 | statement or feeling | (4-word phrase) |
| line 5 | repeated title or synonym | (noun) |

WRITE

Display the poem model or give a copy of the model to each child. Have each student select a subject for a poem and brainstorm all words that could be used in the poem. Instruct each student to write and revise a cinquain.

winter
icy, cold
piercing, chilling, freezing
changing greenness into white
winter

PRESENT

Display the cinquains by mounting them on chalk backgrounds of muted hues. Give each student a 5" x 7" sheet of white paper. Direct the students to color patches on their papers with several colors of chalk and to rub the papers with tissue to combine the colors. Have the students copy their poems on the chalk papers with black ink.

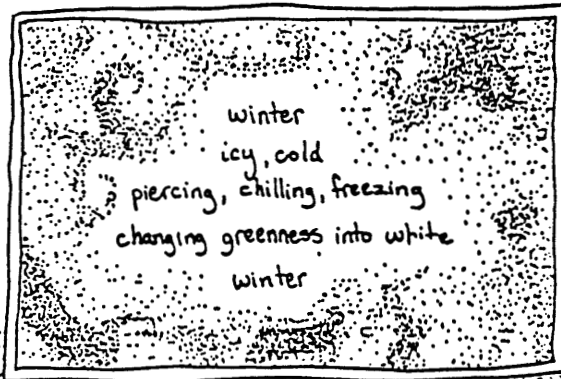
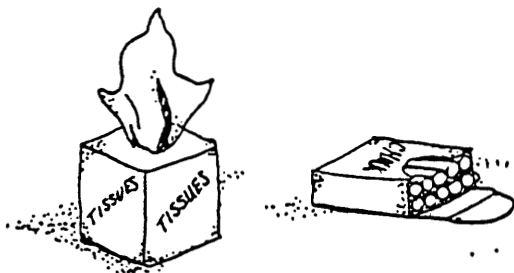

A Cinquain

1. Choose a topic
2. Write a cinquain
3. Illustrate your poem



One Word
(title)

Two Words
(describe title)

Three Words
(describe an action)

Four Words
(express a feeling)

One Word
(refer back to title)

Writing Couplets

Guide your students through the steps of any poetry form you are introducing for the first time. Couplets are simple enough for even very young students, but you will get better results if you establish a sequence of steps to follow as they create poems independently.

**A couplet is a two-line poem that rhymes.
Each line contains the same number of syllables.**

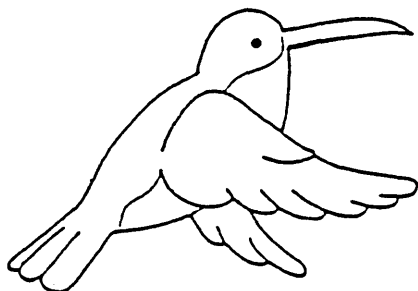

A hummingbird's wings
Are fast little things.

I saw a bird sitting in a tree
Merrily singing his song to me.

Steps for Writing Couplets

- Level I Guide students through all these steps.
 1. Provide the first sentence.
 2. List rhyming words.
 3. Do second lines together.
- Level II Guide students through steps one and two. Students do step three independently.
- Level III Students do all steps independently.

Older students may want to try writing quatrains. These are poems of four lines that rhyme in one of a variety of ways.

- AABB - lines 1 and 2 rhyme, lines 3 and 4 rhyme
- ABAB - lines 1 and 3 rhyme, lines 2 and 4 rhyme
- ABCB - lines 2 and 4 rhyme, lines 1 and 3 do not rhyme
- AABA - lines 1 and 4 rhyme, lines 2 and 3 rhyme

Couplet

READY

A couplet is two lines of rhymed verse with the rhyme pattern (a, a). A couplet can be short or long, but it must always rhyme.

SET

Select a broad theme and have the class brainstorm for rhyming words that could be used in a couplet.

WRITE

Instruct each student to choose a theme and write a couplet. Remind the students that because a couplet has no set meter, the rhyme is most important.

"Spring"

*About spring
I'll sing*

"Spring"

*What I like about the spring
is every single little thing*

Couplets can be combined to form poems of four, six, twelve or more lines.

PRESENT

To emphasize the "linking quality" of a couplet, have the students write each line of their original poems on strips of 2½" x 6" paper. Each student may join his or her strips together to make a paper chain.

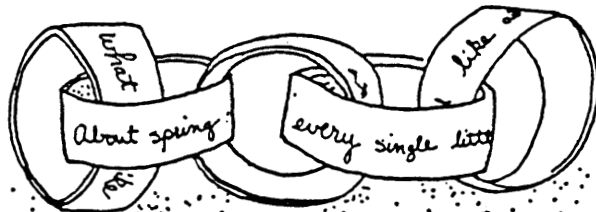

Diamanté'

READY

A diamanté', a poem form which derives its name from its diamond shape, expresses a sharp contrast between two opposite themes. This type of verse involves a knowledge of the parts of speech and thus is best suited for upper-grade students.

SET

Begin the writing activity with a brainstorming session on antonyms. Because nature is full of opposing forces, topics drawn from nature offer great possibilities.

WRITE

Have the class carefully study the diamanté' form below before they begin writing. The fourth line is crucial because it is here that the transition from the description of the theme to its opposite begins. Instruct each student to write a diamanté about some aspect of nature.

| | | |
|--------|---|--------------------|
| line 1 | jungle | (topic) |
| line 2 | abundant, soggy | (2 adj.) |
| line 3 | growing, stretching, living | (3 "ing" verbs) |
| line 4 | vegetation, overgrowth, void, wasteland | (2 nouns/ 2 nouns) |
| line 5 | decaying, drying, dying | (3 "ing" verbs) |
| line 6 | desert | (opposite) |

PRESENT

To accentuate the opposing ideas expressed in this type of verse, have the students make positive/negative backdrops for their poems. Instruct each student to fold a sheet of white paper in half and to carefully cut a design out of a sheet of black paper to make a positive cutout and a negative stencil. Each student should paste the positive cutout on half of the white page and the negative stencil on the other half. Have the students copy their poems on their designs.

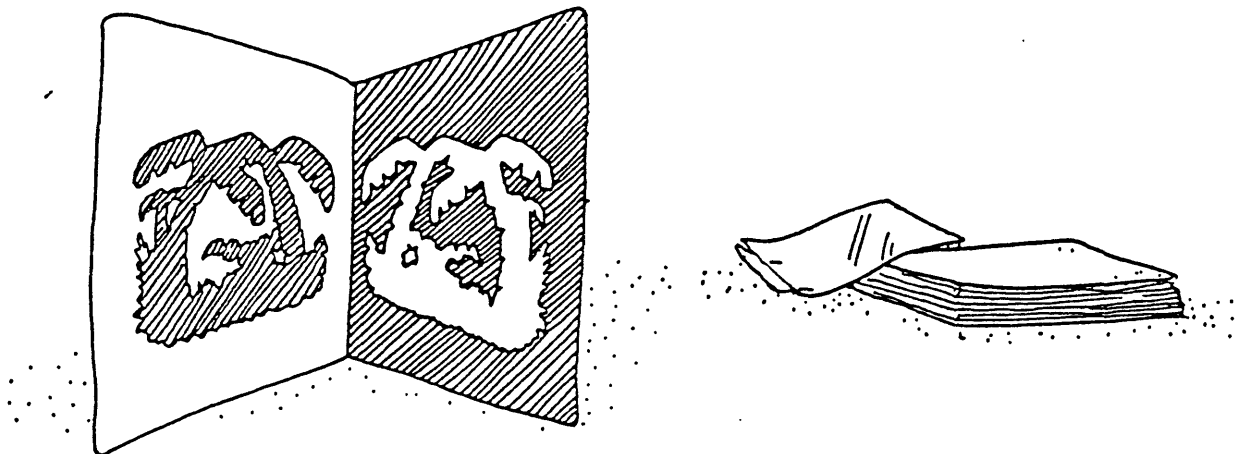

Haiku

READY

A haiku, an oriental verse form containing 17 syllables, is organized into three lines of (5,7,5) syllables each. Nature's wonder is the haiku's theme.

SET

Preparation for writing haiku should involve exposure to published haiku verse. One must appreciate the quality and meter of the haiku before attempting to write a haiku.

WRITE

Reproduce a copy of the haiku form for each student. Instruct each student to write a haiku.

"Rosebud"

| | | |
|--------|---------------------------------|---------------|
| line 1 | <i>Such precious beauty</i> | (5 syllables) |
| line 2 | <i>Upon a stalk so fearsome</i> | (7 syllables) |
| line 3 | <i>How wise is nature!</i> | (5 syllables) |

To help students choose themes, supply the class with nature pictures or allow the students to write their poems outdoors.

PRESENT

Have each student cut a sheet of white paper to 4½" x 12" size. Instruct the students to "splatter paint" prints in delicate hues on their papers. The students may copy their poems on the papers with black ink after the paint has dried.

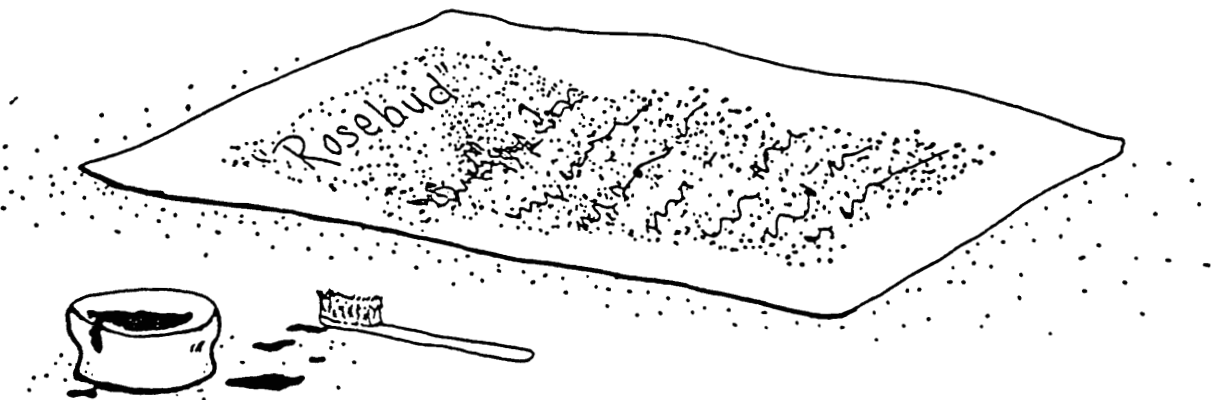

Haiku

Three lines containing 17 syllables which usually refer to nature or the season.

1. Choose a topic
2. Write a haiku
3. Illustrate your poem

Line 1: 5 syllables

Line 2: 7 syllables

Line 3: 5 syllables

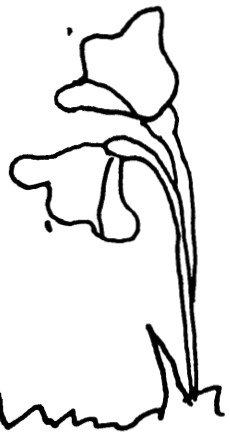

Metaphor

READY

A metaphor is a comparative device used to link two objects that often appear to have very little in common. The beauty of a metaphor is that the poet is free to do the convincing. Even the youngest poet will love this writing activity.

SET

Select a topic and brainstorm every aspect of it. Explore sense words for sights, smells, sounds, tastes, and touches. Now, brainstorm other words that share a common characteristic with the chosen topic.

Night is black.
Soot, smoke, and ink are black.

WRITE

Have each child choose his or her own comparison and enlarge it by adding lines that will make the image real.

*Night is a chimney
smoking, flaring
pushing its blackness over all the earth.*

*Night is a giant leopard
stalking the earth
with its incredible speed.*

PRESENT

The class may illustrate their metaphors with ripped paper artwork. (All of the figures in the illustration are ripped from paper...without using scissors.) Have the students copy their poems below their artwork or on clean sheets of paper.

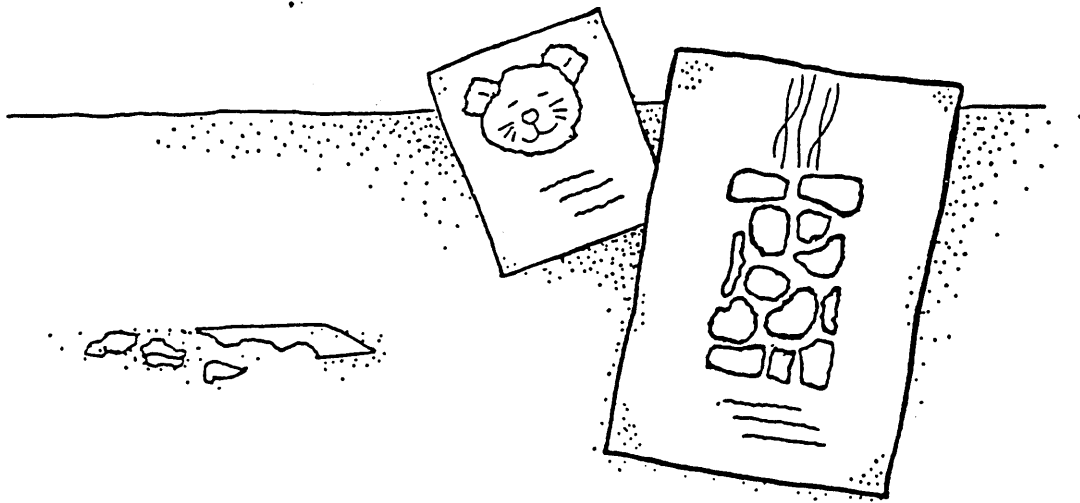

Noun Verse

READY

A noun verse is a patterned poem of four lines. Each line requires a specific type of word. Noun verses are quick, pleasant poems that lend themselves to many subjects.

SET

Copy the noun verse pattern on the chalkboard or reproduce one copy of the pattern for each student. Discuss the pattern with the class and help them write several practice poems.

WRITE

Have each student select a theme and write a noun verse.

| | | |
|--------|---------------------------|-----------------|
| line 1 | <i>butterflies</i> | (noun) |
| line 2 | <i>delicate, graceful</i> | (2 adj.) |
| line 3 | <i>floating, hovering</i> | (2 "ing" verbs) |
| line 4 | <i>monarchs</i> | (synonym) |

PRESENT

Using colored tissue paper, each student may make a multicolored backdrop for his or her noun verse. Have the student paste tissue pieces in overlapping patterns on sheets of construction paper. When the glue dries, the student may print his or her poem in the center of the paper.

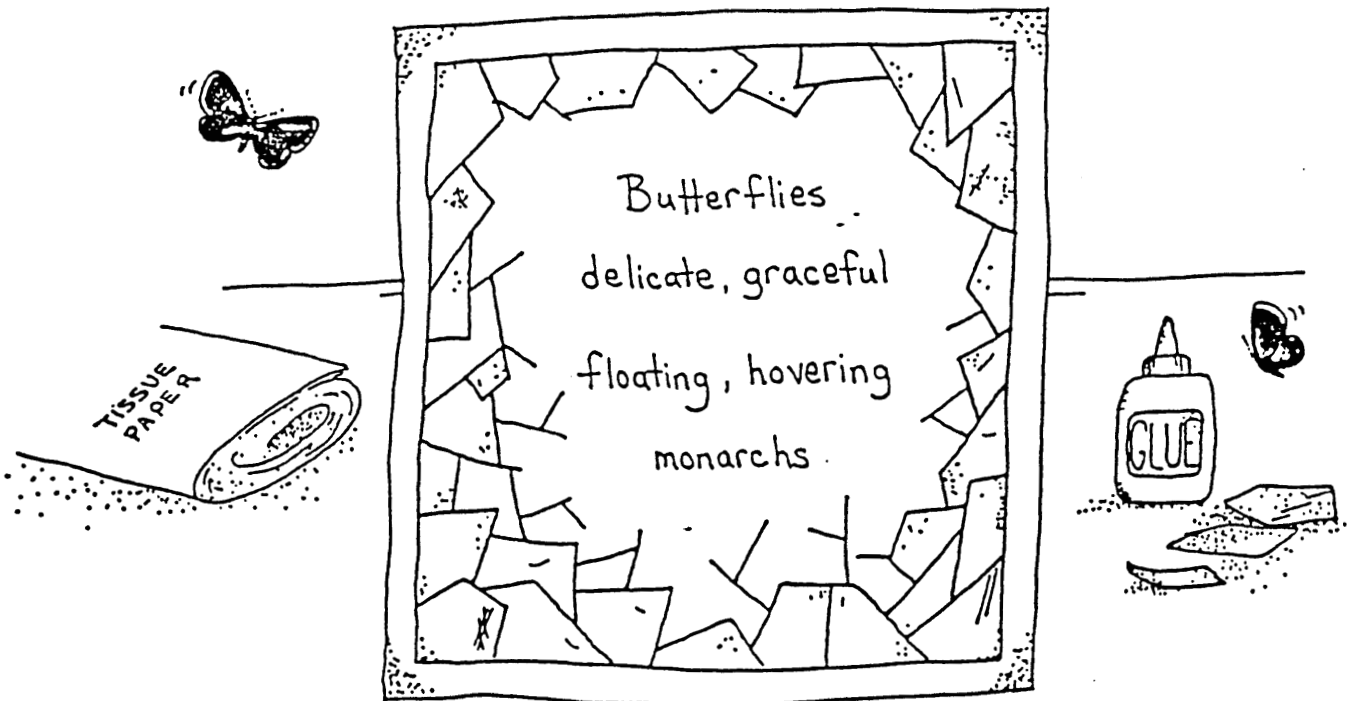

Quatrain

READY

The quatrain, a very popular rhymed verse form used in most elementary schools, is a poem of four lines which follows several rhyme patterns. The quatrain is a light and sometimes humorous verse which is suited to the writing ability and temperament of young children.

SET

Read several quatrains found in existing literature to the class. (The most familiar sources are Mother Goose rhymes.) Display and discuss the various quatrain rhyme schemes. (Like letters indicate rhyming words.)

____ a
____ b
____ a
____ b

____ a
____ b
____ c
____ b

____ a
____ a
____ b
____ a

____ a
____ a
____ b
____ b

WRITE

Have the class brainstorm to make a "word bank" of rhyming words. Instruct each student to select a topic for a quatrain.

My favorite game is tennis, (a)
I'm learning more each day. (b)
My dad thinks I'm a menace, (a)
When I hit the ball his way. (b)

PRESENT

Have the students display their quatrains on shapes that emphasize the chosen themes. For example, poems with sports themes may be copied on shoe shapes cut from construction paper.

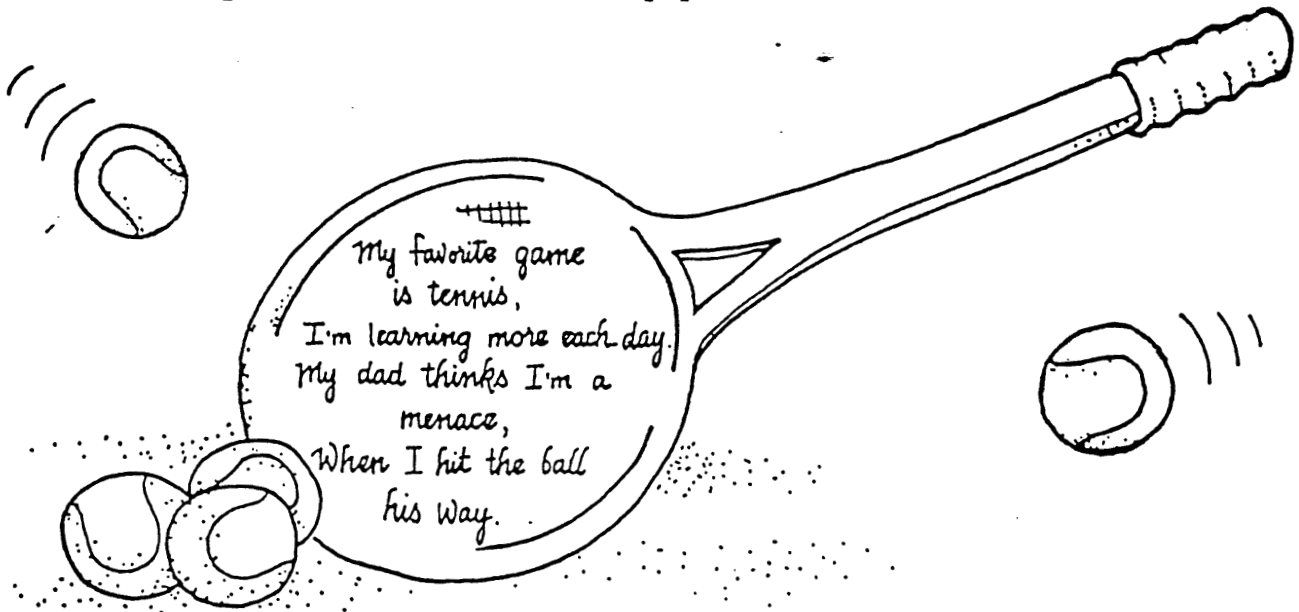

Quintet

READY

A quintet is syllabic verse of five lines that tells a story. The syllable pattern is (3,5,7,9,3) for each line respectively. A quintet brings a visual image alive. Upper-grade students will enjoy the quintet challenge.

SET

Nature photographs provide an excellent springboard for quintet writing. Display several nature photos for the students to use as sources for quintet themes.

WRITE

Distribute a quintet poem model to each student. Spend class time creating a few examples.

| | | |
|--------|-----------------------------------|--------------------|
| line 1 | during fall | (when, 3 syl.) |
| line 2 | deep inside the woods | (where, 5 syl.) |
| line 3 | busy squirrels rush about | (what, 7 syl.) |
| line 4 | gathering nuts and berries galore | (activity, 9 syl.) |
| line 5 | winter feast | (thought, 3 syl.) |

PRESENT

Let the students make owls to accompany their nature quintets. Using a pretzel, a pine cone, paper and glue, each student may construct an owl like the one below. Display the poems and owls together.

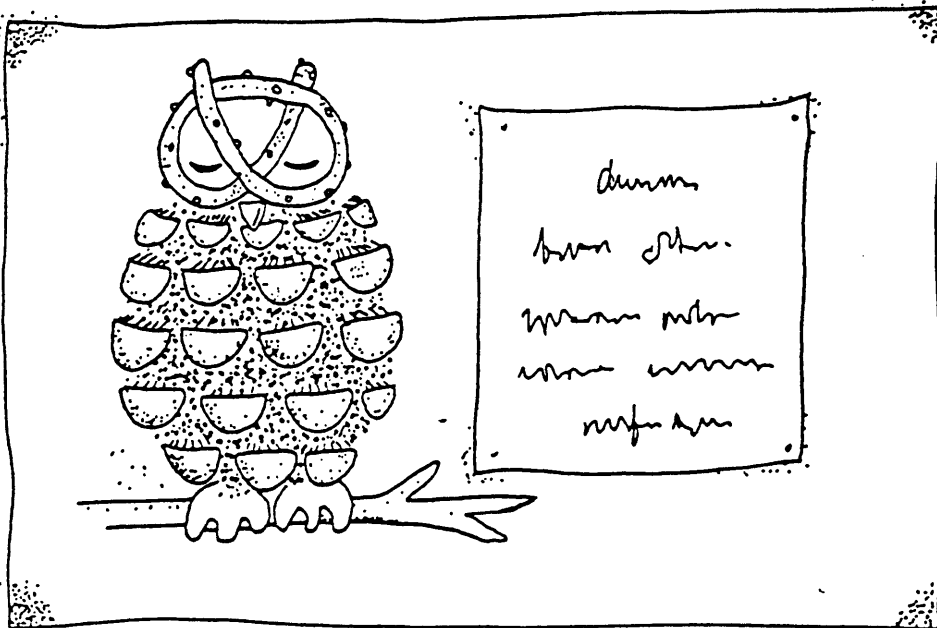

1. Pick an object.

EXAMPLE:

apple

2. Draw:

Get a piece of paper.
Use a crayon or pen.
Draw only the outline of the object.

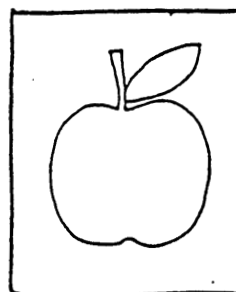

3. Describe the object:

Get a piece of writing paper.
Make a list of words or phrases about the object.
Arrange them in a way that sounds pleasing to you.

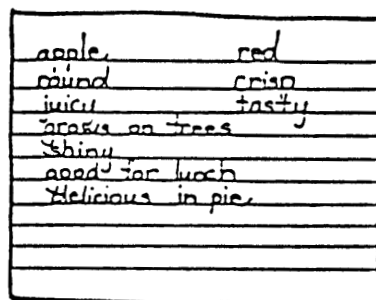

4. Write:

Get a sheet of plain paper.
Put the paper over your drawing.
Clip the papers together with a paper clip so they won't wiggle.
Write your description following the shape of the picture.

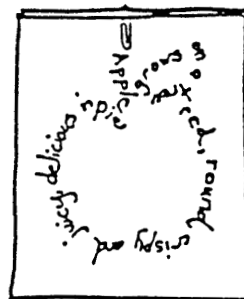

5. Get a sheet of colored paper.
Paste your poem to the paper to make a frame.



Simile

READY

A simile is a device used in comparative statements which is easily recognized by the words like or as.

SET

Building a simile is a simple process when aided by a model.

| | | | | |
|---------|-------|-------------|----|--------------------|
| (topic) | is as | (adjective) | as | (comparative noun) |
| brown | is as | prickly | as | pine cones |

To build similes in class, select a color and brainstorm all of its characteristics (the adjective column). Write all ideas on the chalkboard for easy reference.

WRITE

Instruct the students to write as many comparisons as possible. The combination of three or more similes makes a nice product.

blue is...
as clear as water
as bright as day
as deep as oceans

brown is...
as cool as shade
as foamy as root beer
as gritty as sand

PRESENT

Have the students copy their color similes on square construction paper sheets of the same colors as the simile colors. Each student may run two yarn loops through the square and insert a stick through the loops to make a flag or banner. A variety of colors makes an attractive display.

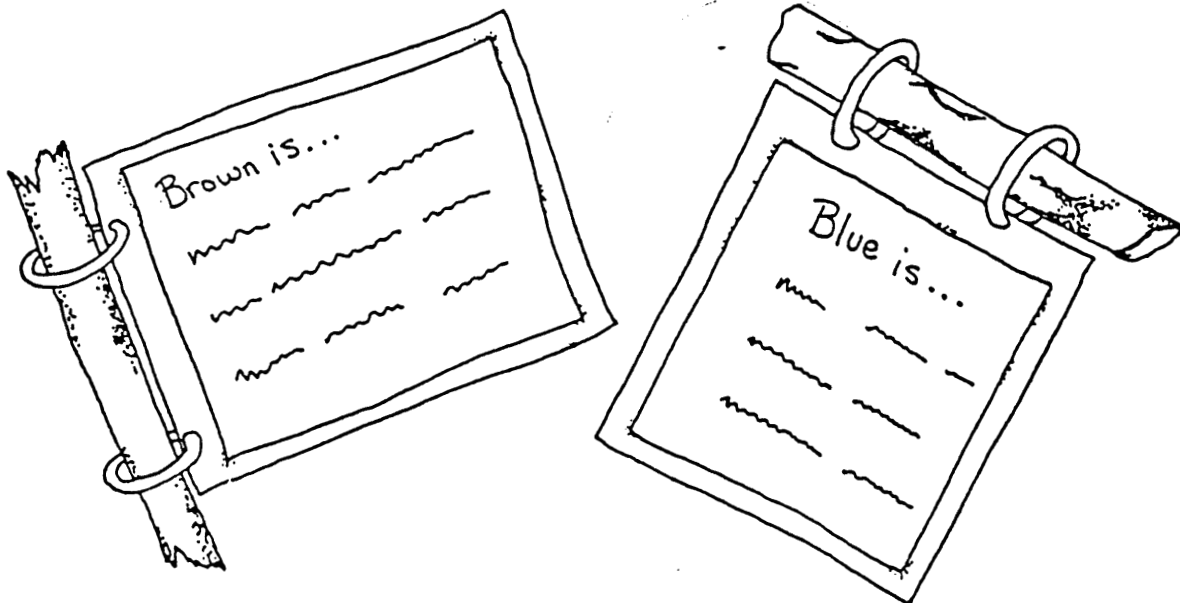

Tercet

READY

A tercet is a rhymed or unrhymed poem of three lines. Tercets may have light and flowing rhyme patterns which are suitable for even the youngest of authors.

SET

You may simplify the process of introducing the class to rhyme patterns by using visual models. The tercet may follow any of the patterns below. (Like letters indicate rhyming words.)

_____ a
_____ a
_____ a

_____ a
_____ b
_____ a

_____ a
_____ b
_____ b

WRITE

Animals make fine themes for tercets. Select three to five animals and have the class brainstorm to make a list of rhyming words. Instruct each student to write a tercet about one of the selected animals.

"The Bird"

A yellow bird (a)
Can sing a song (b)
Without a word (a)

PRESENT

Potato-print backgrounds provide an excellent publication mode for animal tercets. Give each child half of a potato and instruct the student to carve his or her chosen animal in the end of the potato. Direct the students to dip their potatoes in tempera paint and then press their potatoes all over sheets of construction paper. When the paint dries, the students may copy their poems on their printed papers.

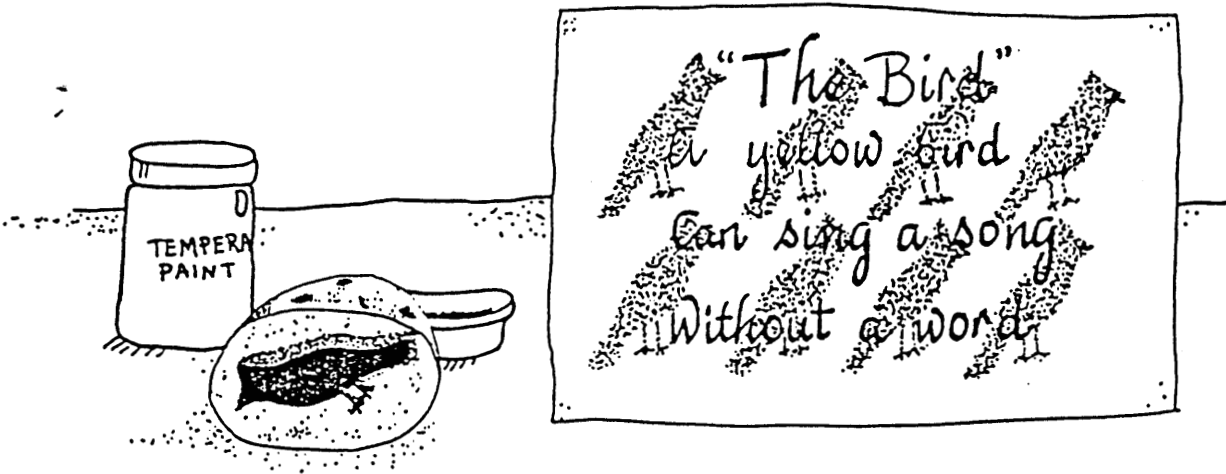

The Future Is "R's"

ACTIVITY ONE

If we follow the "3 R's" of resource conservation — *recycle*, *reduce*, and *reuse* — a bright future can be ours. But if we don't, the prospects for the Earth's environment could be much dimmer.

What's the problem? Trash! There's too much, and we create more every day — about 200 million tons each year! We soon may run out of space for it. Landfills, where trash is dumped and buried, are in short supply, and everyone says, "Hey, don't put a dump in my neighborhood!"

Materials found in trash come from either *renewable* or *nonrenewable* natural resources. Paper and other wood products, for example, come from organic, *renewable* trees. But other resources taken from the Earth — metals, fossil fuels like oil, etc. — are *non-renewable*; they took millions of years to create, but we could use them up very quickly if we're not careful.

How can we help? We can (a) *recycle* materials to be used to make new objects and buy things made from recycled materials; (b) *reuse* items whenever possible; and (c) *reduce* the amount of trash we produce by buying fewer disposable or over-packaged items.

Part I

Here are several manufactured items commonly used in the home. For each one, suggest a way that people could...



1. aluminum soft drink can



2. plastic tape dispenser



3. newspaper



4. plastic lawn chair



5. wire coathanger



6. steel or tin food can



7. glass bottle



8. plastic milk bottle

RECYCLE IT
(into what?)

1. _____
2. _____
3. _____
4. _____
5. _____
6. _____
7. _____
8. _____

REDUCE THE AMOUNT
OF MATERIAL NEEDED

1. _____
2. _____
3. _____
4. _____
5. _____
6. _____
7. _____
8. _____

REUSE IT
(how?)

1. _____
2. _____
3. _____
4. _____
5. _____
6. _____
7. _____
8. _____

Part II

Most things in your home can be recycled. A material that can be recycled — including such things as paper, cardboard, aluminum cans, plastics and glass — is called a *recyclable*. When recycled, these materials are intended to be made into new items, known as *recycled* products. Even though recyclables are sent to a recycling center, however, they are not being truly recycled until someone makes them into new, recycled products to be bought and used. This is known as "closing the loop," and is the only way that recycling can really work. So purchasing recycled products is just as important as recycling itself — and is essential to "closing the loop."

Look for this symbol: . It means that products are *recyclable* and/or are made from *recycled* material. Be sure to read packages, too, and look for statements such as "contains 100% recycled material."

After taking this sheet home, look around your house and, with your parents' or guardians' help, list five things that are recyclable, and five things that are made of recycled material.

RECYCLABLE ITEMS _____

ITEMS MADE FROM RECYCLED MATERIALS _____

Part III

Take home the plastic RENEW® bags your teacher gives you. Follow the activity suggestions printed on the carry bag. What are some ways you can reuse a small plastic bag? Bring your ideas to class.

BOTTLE BIOLOGY⁷⁸

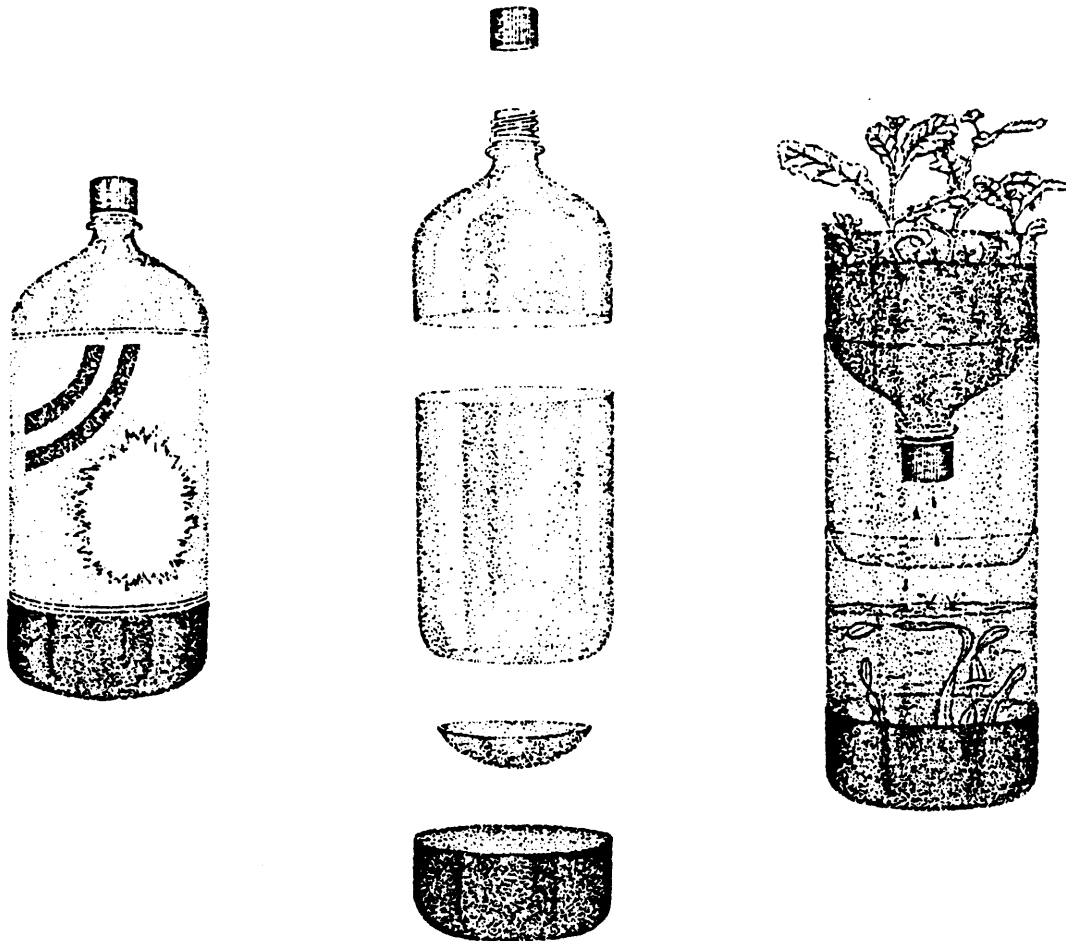

Exploring:

- *Ecosystem Interactions*
- *Population Dynamics*
- *Biodegradation*
- *Microbial Fermentation*
- *Experimental Design*

Hands-on Biology with Plastic Containers

*Bottle Biology Program, University of Wisconsin-Madison, Department of Plant Pathology,
1630 Linden Drive, Madison, WI 53706, (608) 263-5645*

Recycled  Recyclable

BOTTLE BIOLOGY



W I S C O N S I N

Bottle Biology is a classroom-tested approach to hands-on biology which allows students on all levels to become engaged in the actual process and activity of doing science: asking questions, creating experiments, testing hypotheses and generating "answers". Teachers and students working with Bottle Biology use throw-away containers to explore many areas of the life sciences, leading to a better understanding of ecosystems, local environments, and biotic interactions. Our activities present a low-cost and accessible scientific world, which includes microbes, plants, insects and environmental interactions, as the ground from which to pose their questions and launch their investigations. Some of the more popular explorations include making composting columns, Korean *kimchee* and sauerkraut fermenters, stacking eco-habitats, insect environments and modelling environmental interactions such as nutrient runoff and groundwater contamination.

We are in our third year of funding by the National Science Foundation, and these pages represent our continuing efforts to put Bottle Biology concepts and theories into practical resource formats. We are in the process of writing a Bottle Biology Manual which will be a compilation of bottle ideas and extensions generated by our project and associates thus far. Remember, many of our ideas come from teachers, students and others who do science in throw-away containers and share their creations with us. We also appreciate feed-back from the classroom: the more we know about how teachers and students use Bottle Biology and what their needs and wants are, the more successful we can be in providing the kinds of materials that promise easy and exciting integration into the classroom.

If you have any bottle frustrations or inspirations, please write or call—we'd love to hear from you. Enjoy your bottle work!



EcoColumn

*Bottle Biology is an instructional materials development program funded by a grant from the National Sciences Foundation administered by the University of Wisconsin-Madison
Bottle Biology Program, Dept. of Plant Pathology, UW-Madison,
1630 Linden Drive, Madison, WI 53706 (608) 263-5645*



Bottle Basics

Create hands-on scientific explorations using throw-away containers

Plastic beverage bottles provide the primary material for Bottle Biology explorations. They are readily available — millions are produced and discarded daily — and they are easy to cut and combine in a wide variety of ways for science projects. These Bottle Basics are meant to get you started, showing how plastic bottles can be taken apart, cut, and connected. Once these basic techniques are mastered, you can use your imagination to combine bottles and parts of bottles (as well as other disposable containers) into the apparatus needed to try out any number of ideas for fascinating projects in the life sciences..

Removing the Label and Base

Both the bottle label and base may be readily removed, but for some projects or parts of projects it might be best to leave the base glued firmly to the bottle. Aquariums and compost columns, for example, will be more stable if the lowest unit has the base attached. In almost all projects the label should be removed. The label and base are held in place with a heat-sensitive glue. To remove them, the glue must be softened with heat.



A) Fill the bottle about 1/4 full with very hot (120° - 150° F) water. If the water is too hot (170° - 212° F) the plastic will soften, warp, and may permanently crumple. Screw the cap back on firmly. This will retain pressure inside the bottle allowing you to hold the bottle tightly without crushing or denting it.

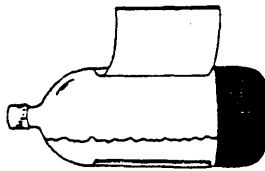

B) Tip the bottle on its side so the water warms the area where the label is attached to the bottle — this will soften the glue. Catch a corner of the label with your fingernail and gently peel it from the bottle. If there is resistance, you may need hotter water.



C) To remove the base, tip the bottle upright so the hot water warms the glue holding the bottle bottom to the base. Hold the bottle tightly and slowly twist off the base.

D) Remove the cap and pour the water out slowly. You might try swirling the bottle around as it begins to empty, causing the water to form a vortex resembling a tornado funnel. This lets the water to swirl slowly out of the bottle mouth without buckling the sides.

E) Usually most of the glue from the label and base is left on the bottle. It can be removed by scraping with a sharp-edged piece of metal or plastic while the glue is still warm. It can also be chemically softened and removed with a solvent such as cleaning fluid. Put a small amount on a paper towel and rub. This works best if most of the glue has been removed by scraping. Be sure there is adequate ventilation.

F) Save all parts, bottle, cap, and base. You now have the raw materials to begin fascinating explorations!

Bottle Basics - Cutting Techniques

Plastic bottles can be cut and modified in a great variety of ways — but before you begin cutting, plan carefully. Remember that some bottles are wider than others, some have larger bases, and some have more tapered shoulders. The bottle shape and location of the cuts affect how your pieces fit together.

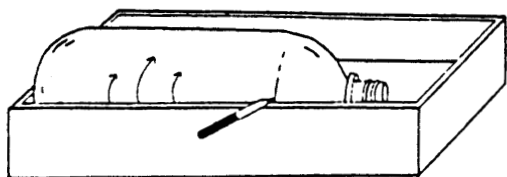

1) Place bottles on their sides in an empty drawer, tray, or box — shallow cardboard flats and computer paper boxtops work well. Hold the bottle up against the side and corner of the box to stabilize it while rotating. Brace a felt-tip pen against the box with the tip just touching the bottle and roll the bottle slowly around. This will leave an even line encircling the bottle. Sometimes it's easier to do this cooperatively. One person holds the bottle and rotates, while the other keeps the pen tip touching the bottle.

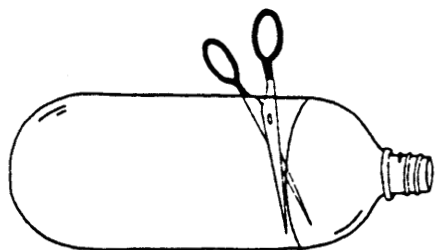
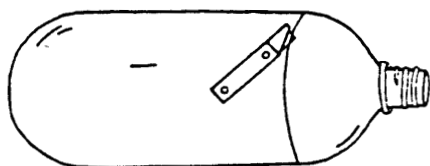

2) Use a single-sided razor blade or utility knife to begin the cut, slicing along the cutting line about two inches. Insert the tip of the scissors and snip your way around the rest of the cutting line. Because the scissor blades tend to catch in the plastic, it may be easier to snip along with just the tips.

Trim away rough edges and irregularities with the scissors. Once the bottle is cut open, you can snip more from the shoulder, hip or side if you decide shorter lengths are needed. When in doubt about how project pieces may fit, cut them a little too long — you can always remove the extra length. Because it is more difficult to draw lines once a bottle has been cut, draw all intended lines before cutting.

Basic Bottle Anatomy

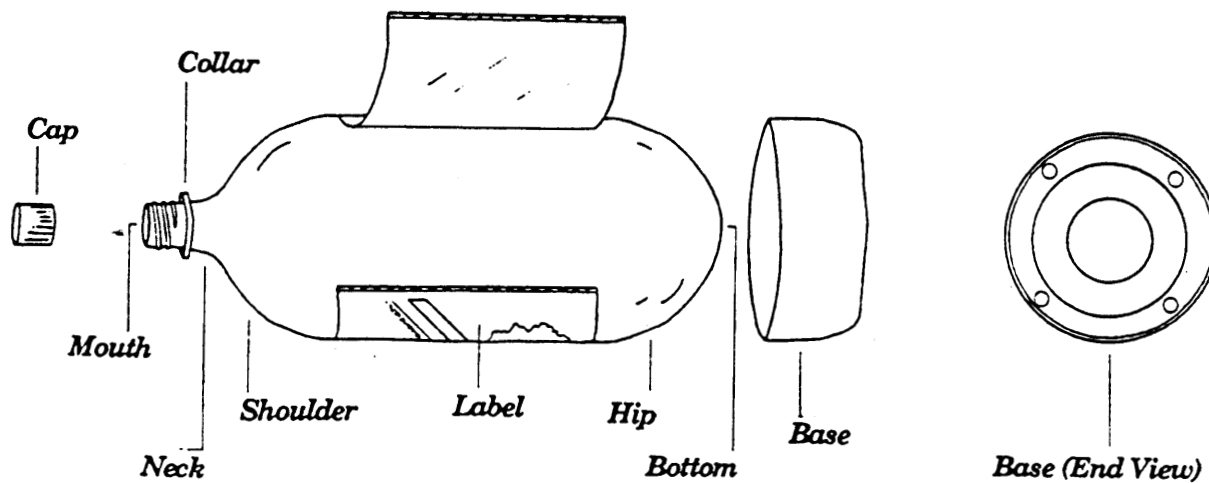



TerrAqua Column

Explore interactions between terrestrial and aquatic systems

Terrestrial and aquatic ecosystems are frequently viewed as two separate and independent entities. However, land and water systems are connected in many ways. One of the major links between terrestrial and aquatic ecosystems is water.

Water is the life blood for the terrestrial community and usually finds its way to wetlands, rivers, lakes and oceans. Passing through the soils of fields and forests, the water picks up compounds such as nutrients and agricultural chemicals. As this solution enters an aquatic community it then modifies biological, physical and chemical aspects of that community.

Construction of a TerrAqua Column can allow you to model and explore relationships between land and water ecosystems.

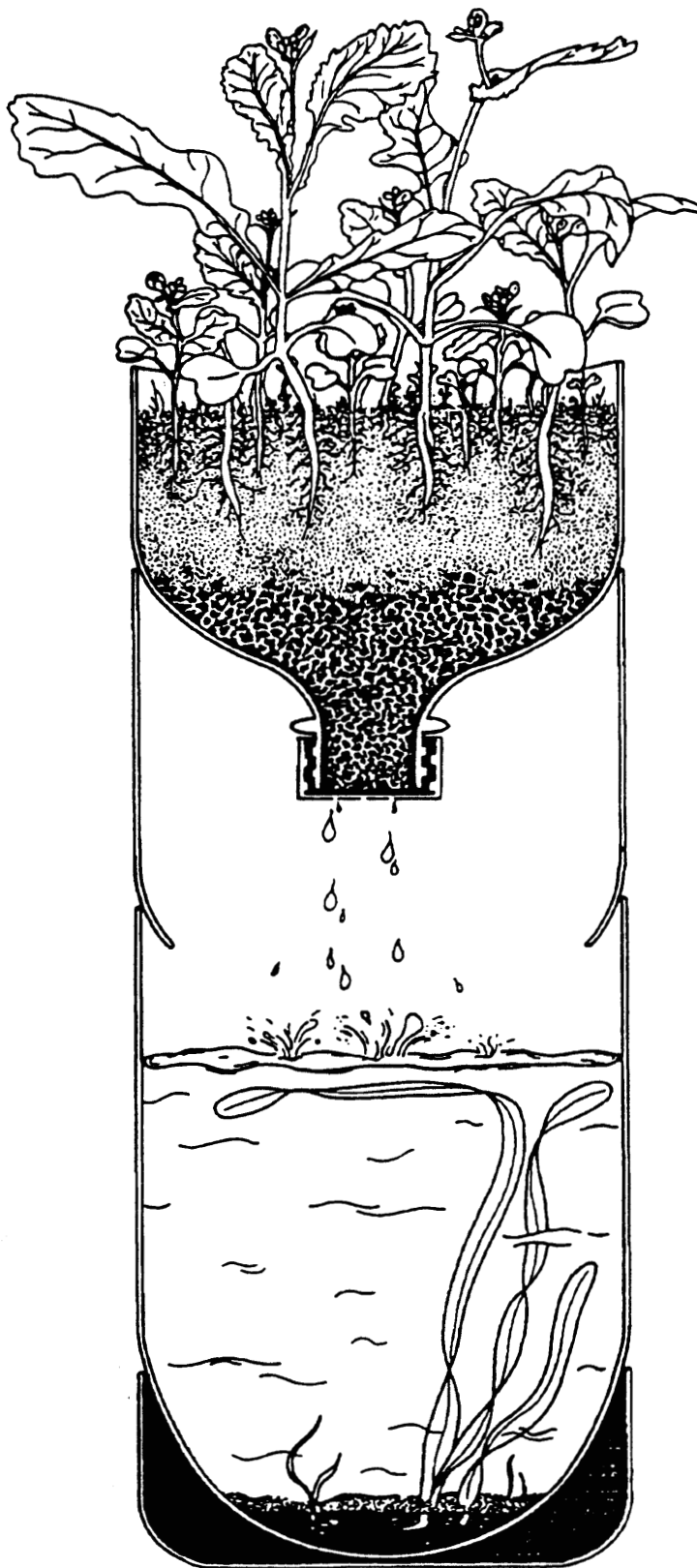

Bottle Anatomy

Bottles cut across the shoulder or hip have tapered sides

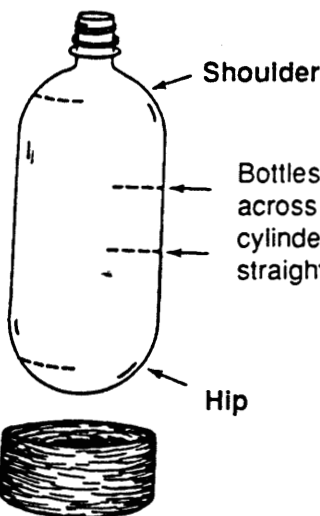

Cut Bottles

1st Bottle

Cut, leaving 1-2" of the cylinder on the shoulder

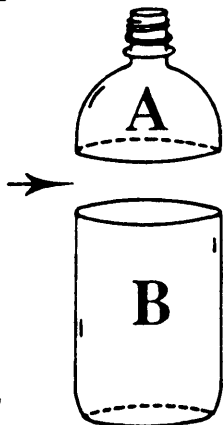

Cut, leaving 3/4" of the hip on the cylinder



2nd Bottle

Cut across top of cylinder leaving straight sides

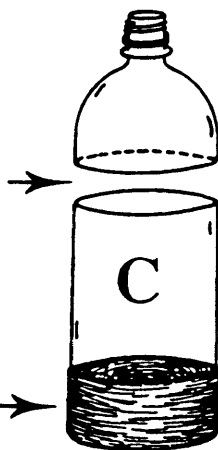

Leave base attached

Combine Bottles

Invert Part A onto the straight side of Part B

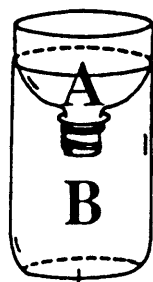

Slide the A/B unit onto C

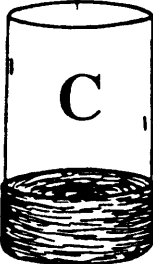

Add Finishing Touches



Punch small holes in cap

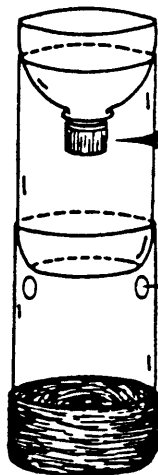

Screw cap onto bottle

Cut or melt holes into the top sides of the lower bottle

Studying the Flow of Agricultural Chemicals

Recent concerns about the interaction between land use and water quality have led to the study of nutrient and chemical flow from terrestrial to aquatic ecosystems. Fertilizers and pesticides used for lawn care and agriculture readily make their way into aquatic systems causing water quality problems ranging from algal growth to the build-up of toxins in drinking water.

The TerrAqua Column allows for the study of various aspects of land-water interactions such as the effects of:

1. Nutrient sources for the terrestrial system
2. Nutrient concentration
3. Type and amount of soil in the terrestrial system
4. Type(s) of plants in the terrestrial system
5. Physical factors such as temperature and light
6. Effect of various pesticides
7. Frequency of fertilizer or pesticide application.

Various aspects of the terrestrial and aquatic systems can be monitored such as the growth of plants and algae. For plants in the terrestrial system, percent germination, height, weight, leaf size, length of life cycle, and seed production can all be measures of plant health. Populations of algae, aquatic plants and animals can be monitored in aquatic systems. Changes in the soil microorganism populations and soil structure can also be monitored. Finally, the solution flowing from the terrestrial to the aquatic system can be examined with a Fast Plant bioassay (*Fast Plant Notes*, Spring, 1990).

Column Construction

This column is composed of two units. The upper, terrestrial unit is made by cutting a bottle to make pieces A and B as shown in the illustration. These two pieces can be held together by a wide transparent tape such as bookbinding or mailing tape. The lower, aquatic unit is made by cutting a second bottle to produce piece C. Biological materials for the aquatic system can come from a pond, lake, puddle or fish tank and can include algae, phytoplankton, zooplankton, aquatic plants and insects. A variety of plants can be used in the terrestrial system. Because of their rapid life cycle, Fast Plants work well.



Compost Columns

*Where do things go when they die?
Explore the process of decomposition.*

Composting is based on the biological process of decomposition. What turns plants and animals into compost? Microscopic bacteria and fungi, which feed on dead tissue, are the chief agents.

What affects the composting process? The amount of moisture and air, temperature, light, sources of bacteria and fungi, and the nature of the decomposing material are all critical. The presence or absence of air (oxygen) is one of the most important factors in composting. The practice of composting allows air and moisture to speed the natural process of biodegradation. Making a compost column lets you see and experiment with this process, and witness nature's world of recycling.

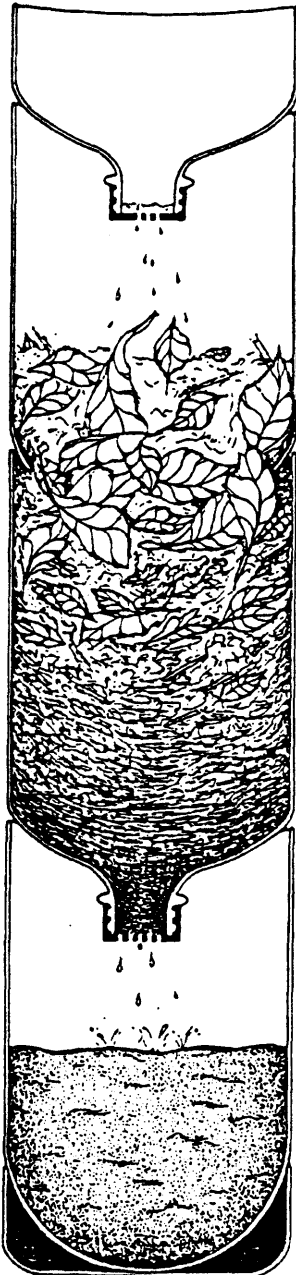

Materials Needed:

- Three 2-liter plastic beverage bottles
- Hot tap water, knife or razor blade, scissors, marking pen, sharp needles for poking holes, clear tape, netting or mesh fabric, rubber bands.
- Organic materials for composting, such as kitchen scraps, leaves, newspapers, animal manure, and grass clippings.

Procedure:

Remove the bases from two bottles, and the labels from all three, by pouring about two cups of hot tap water into the bottles. (Columns can also be made from bottles that don't have removable bases.) Replace the cap, tilt the bottle so the water softens the heat-sensitive glue, peel off the label and twist off the base. Pour out the water, draw cutting lines around the bottle, make incisions with the knife and cut with scissors and assemble as illustrated.

Most columns will require air holes for ventilation, and these can be poked into the plastic with a sharp cold needle or with a needle or paper clip heated in a candle flame. Alternatively, larger holes can be cut into the sides with the knife and covered with fine mesh fabric held in place with tape. A piece of mesh fabric over the lower end allows for drainage. Refer to the illustrations. Add ingredients for composting through the top of the column.

Explorations:

The possibilities for compost column explorations and discoveries are endless. There is no limit to what can be put inside, or the conditions under which the column can be kept. In addition to simply observing changes, you can design experiments which explore the effects of variables on you column.

Compost Column Construction

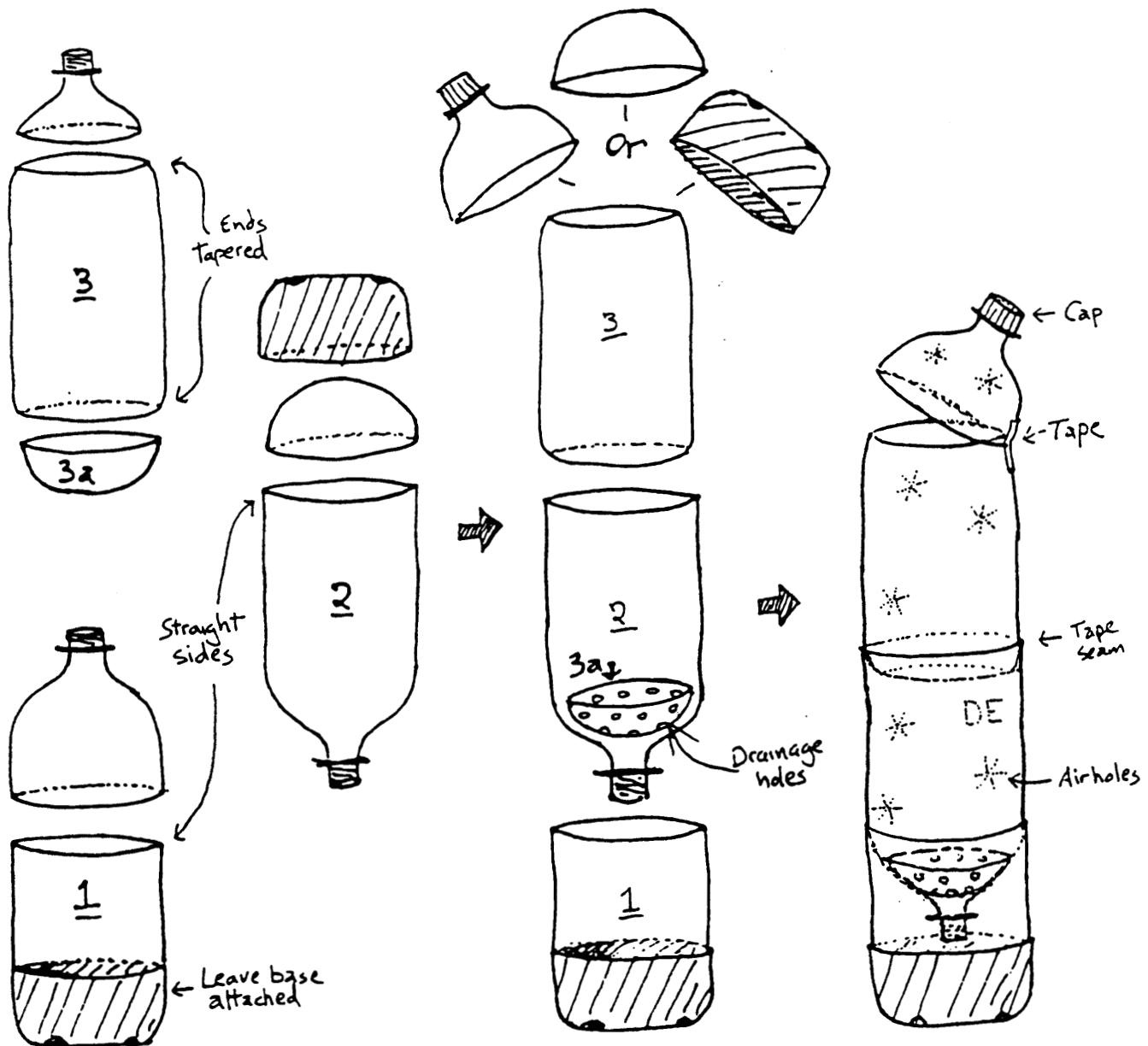

Two Possible Explorations:

- **Leaf Digester.** Make two columns, and use a balance or postal scale to weigh out two equal quantities of leaves. Loosely pack one column with leaves only. Mix about a half cup of garden soil to the other batch of leaves and loosely pack the second column. Pour equal amounts of pond or rainwater into each column, and wait several hours for it to percolate through. If none comes out the bottom, add more in equal amounts until about a half cup drips into the reservoir. Schedule a rainstorm to occur in the column every few days, pouring the drippings back through the column. Which column decomposes faster and why?
- **Compost Tea.** Compost columns can be used to generate a liquid fertilizer called "compost tea". Try making several columns using different ingredients, whose drippings will differ in color and chemistry. Use this liquid to water and fertilize identical sets of seedlings to see how different brands of "tea" affect plant growth. Some drippings, such as those from a column filled with leaves from a black walnut tree, may even inhibit growth.



EcoColumns

Creating miniature systems that can be interconnected to explore natural systems

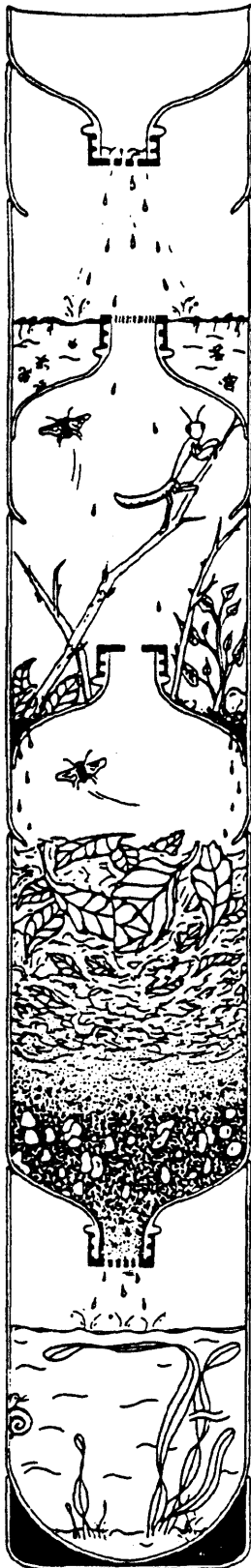

This advanced Bottle Biology activity makes possible a fascinating variety of dynamic life sciences explorations. EcoColumns can be designed to model many kinds of aquatic and terrestrial environments, with habitats and niches for insects, spiders and small vertebrates. Individual modules can be used alone or stacked into a stable, free-standing column. Modules can be kept isolated from one another or be interconnected to stimulate interactions between systems.

The tapered sides of the Eco-Column chambers allow a closeup view of organisms from aquatic environments. Roots of plants are also made visible, and the module can be viewed from underneath as well. Studies of ecology, population dynamics, water chemistry and many other sciences can be conducted in an Eco-Column. Columns can also simply be constructed and observed, noting changes over time. There is no limit to the number of ways that the modules can be designed and put together. What kind of biological question could you try to answer in an EcoColumn?

Materials:

- Several one or two liter beverage bottles
- Bottle Basics tools for marking and cutting bottles, plus equipment for making ventilation and port holes
- Clear waterproof tape (Most postal and bookbinding tapes are waterproof.)
- Silicone sealant (Available at most hardware stores, for chambers that will need to hold water.)

Explorations

- Consider the different types of habitats you might expect to find in an ecosystem such as a tropical rain forest. How many of these habitats can you include in one EcoColumn construction?
- Put a fruit fly module below a chamber containing a hungry spider or praying mantis. Connect them with a narrow tube which will allow flies to wander upward but which prevents the spider or mantis from descending into the fruit fly chamber. Fruit flies will live off of banana peels and other rotting fruits.
- Plant seeds or small plants in a chamber filled with soil (or filled up to the bottle mouth). In time, root growth will be visible along the clear sides, and from underneath as well. Patterns of root response to crowding, overwatering, and other variables could be compared among different species of plants.

EcoColumn units are modules made from soda bottle pieces which can be stacked to make numerous different models of ecological systems.

Tips

Use the same brand of bottle for all of the EcoColumn units which will make up a final construction. Different brands of bottles can have slightly different diameters or shapes and this can lead to complications. Also, some bottles have bulges at the top of the hip which can make it difficult to stack units. These bottles should be avoided.

Use a waterproof tape to fix bottle part A to part B. Some clear tapes are waterproof, but check first by taping a test strip to a scrap piece of bottle and leaving it under water overnight.

If the unit is going to contain a terrestrial system be sure to add drip holes in piece A. Units with drip holes high up part A will hold some water and can be used to make a unit which is bog-like in character.

If the EcoColumn unit is going to hold water, seal the A/B joint with a silicone sealant after taping. The sealant also acts as a glue to make a strong joint

Bottle Anatomy

Bottles cut across the shoulder or hip have tapered sides

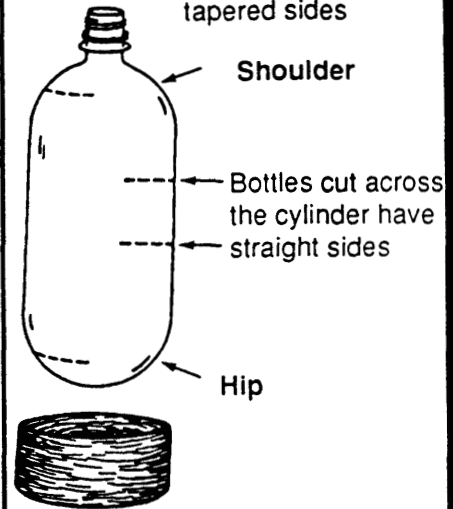

Cut and Combine Bottles

1st Bottle

Cut to leave apx. 1/4" of cylinder on shoulder



Slide part A down into the hip of B

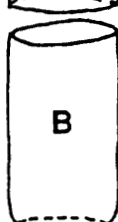

Cut to leave apx. 3/4" of hip on cylinder



Tape or glue the A/B joint

Slide the A/B unit onto C

2nd Bottle

Cut across cylinder to leave straight sides



Leave base attached

Add Finishing Touches

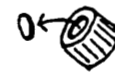

Bore or punch hole(s) in cap.

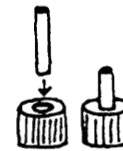

Option: place tube into hole. Fit should be snug.



Screw cap back onto top of bottle.

Make drip holes

Add air holes



Kimchee: Korean Delight

Fermentation Experiments with Bottle Biology

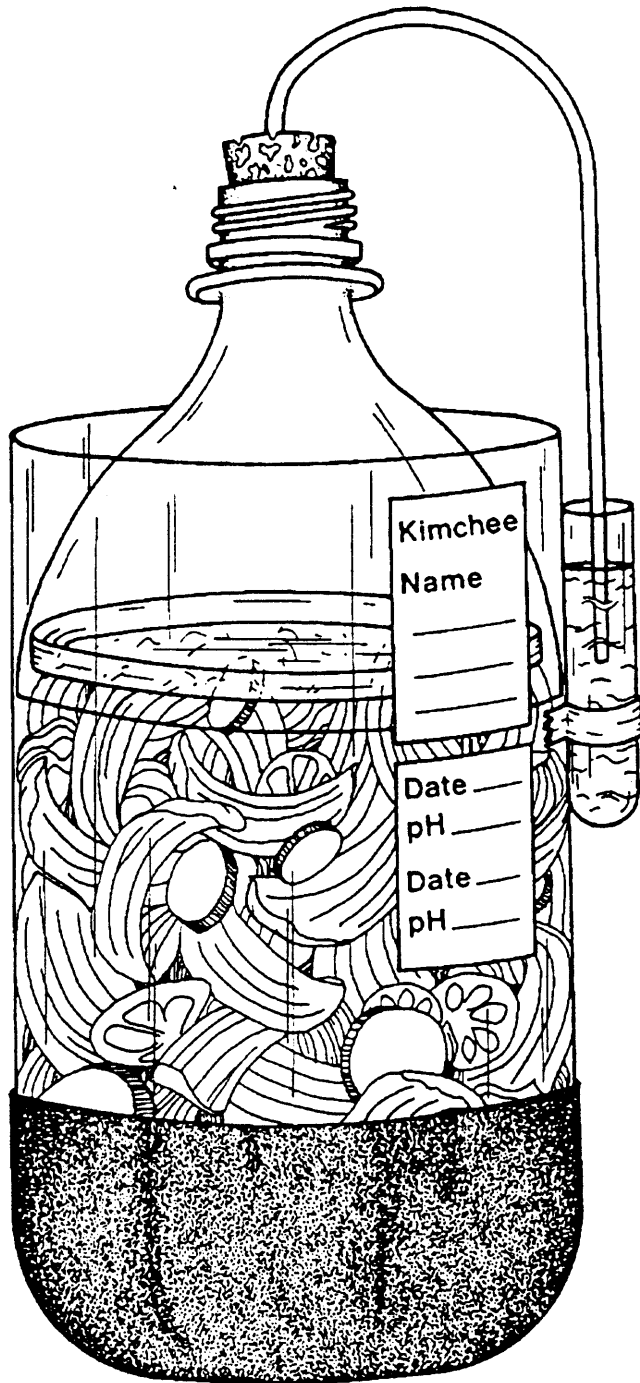

Pickling is one of the most ancient forms of preserving food. It involves the microbial conversion of sugars into lactic acid through the growth and activity of acid-forming bacteria known as *lactobacilli*. As *lactobacilli* grow, they convert the natural sugars in plant juices into lactic acid. Under the high acidity (= low pH) created by the *lactobacilli* other food spoiling organisms cannot grow. *Lactobacilli* are found almost everywhere in our environment and are known as anaerobes because they grow under conditions in which oxygen is lacking. Many foods can be preserved through natural pickling. Some common ones are sauerkraut, yogurt, dill pickles, and silage for livestock. The ancient Chinese cabbage product known as kimchee is a major part of the Korean diet.

You and your students can make kimchee and study lactic acid fermentation in a two liter bottle by using the following recipe and procedure.

Ingredients:

- 1-1½ kg head of Chinese cabbage (*Brassica rapa*; also called napa or petsai), cut leaves into 5-7 cm chunks.
- 1 red hot chili pepper, chopped (or hot chili powder)
- 2 cloves garlic, thinly sliced
- 3 tsp. non-iodized (pickling) salt

Materials:

- one 2 liter soda bottle
- large plastic lid (approximately 9 cm in diameter) from jar or petri plate
- pH indicator paper (litmus paper, obtainable in small vials from lab suppliers)
- small plastic pipette

Kimchee...

TRY IT, YOU'LL LIKE IT!

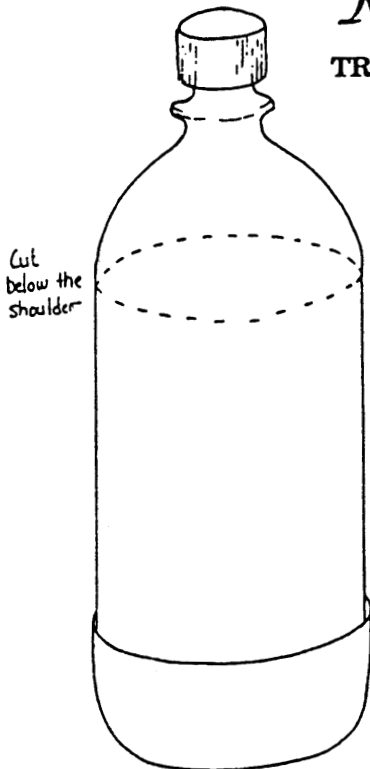

Figure 1

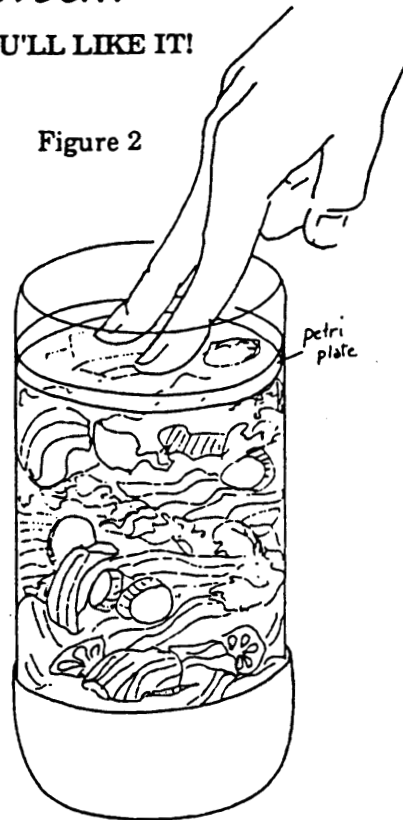

Figure 2

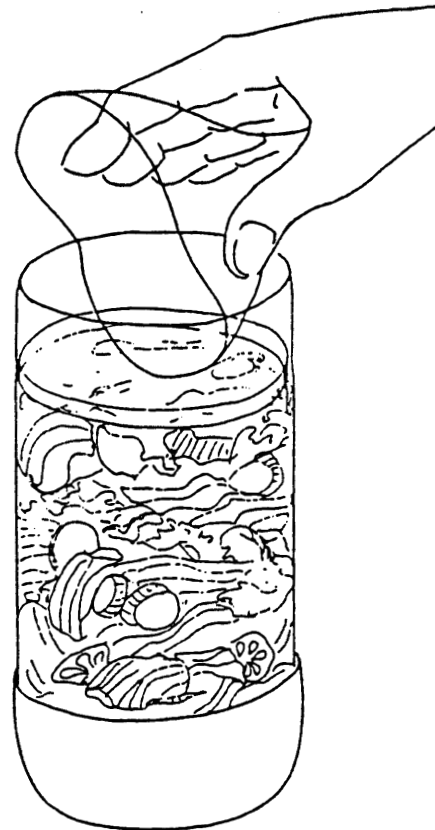

Figure 3

Procedure:

1. Cut the bottle just below the shoulder as shown in the illustration.
 2. Alternate layers of cabbage, garlic, pepper and a sprinkling of salt in the soda bottle, pressing each layer down firmly until the bottle is packed full. **Caution: when working with chili pepper, take care not to touch eyes or mouth. Wash hands thoroughly when finished.**
 3. Place the lid, rim side up, on top of ingredients and press down again. NOTE: within a few minutes liquid begins to appear in bottom of bottle as salt draws liquid from the cells of the Chinese cabbage.
 4. Press down occasionally for an hour or two. After that there should be sufficient space to fit the bottle top inside the bottle bottom, forming a sliding seal.
 5. Upon pressing firmly with sliding seal, cabbage juice will rise above the petri plate and air will bubble out around the edge of the petri plate.
 6. The Chinese cabbage will pack to 2/3 or 1/2 the volume of the bottle. Press daily on the sliding seal to keep the cabbage covered by a layer of juice at all times.
 7. Notice bubbles of gas escape each day when pressed. The gas is produced as bacteria grow on the sugary contents of the Chinese cabbage juice in the salty solution.
 8. Measure and record the acidity of the fresh juice on top each day with pH indicator paper. Tape the indicator paper on the bottle and write the pH (acidity level) above it.
 9. Note the increase in turbidity and change in acidity together with the continued production of gas as the pickling proceeds.
- Did you notice the aroma of the garlic and pepper? These ingredients flavor the product. After a few days to a week or more (depending on the temperature), the pH will have dropped from 6.5 to about 3.5 and you will have kimchee!

APPENDIX F

THEMATIC INTEGRATED UNIT

THEME: "MEMORIES"

FAMILY LIFE

Integrated Planning Tool

Learner Outcome

Grade Level: Grade 5 **Time:** 2-3 Weeks **Theme:** Memories

Strand: Family Life

Focus/Outcome: To identify family impact on each member's development.

Assessment

The learner will plan and create a family memory. After a week has passed, students will write a narrative composition on how or why their memory impacted their family members.

Content/subject area:

Health

Specific Objective:

The learner will describe the importance of creating healthful and loving family memories.

Content/subject area:

Language

Specific Objective:

The learner will apply English skills in a creative writing and narrative composition activity.

Content/subject area:

Reading

Specific Objective:

The learner will listen for and evaluate main ideas, supporting details and conclusions.

Content/subject area:

Social Studies

Specific Objective:

The learner will identify why history is important for the development of our country.

Content/subject area:
Music

Specific Objective:
The learner will identify and explain lyrics of a contemporary song.

Content/subject area:

Specific Objective:
The learner will apply drawing skills in an illustration.

Content/subject area:

Specific Objective:

Content/subject area:

Specific Objective:

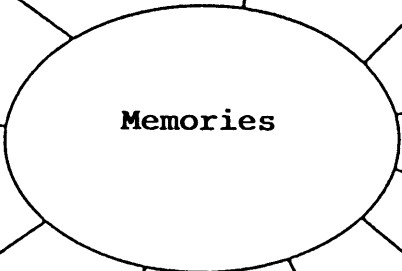

Student Reading

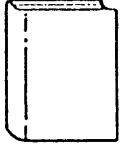

Choose a favorite trade book that depicts some type of memory.

Give a book report to the class identifying the main idea, details and conclusions gathered from the story.

Teacher Read-Alouds (listening)



Read Now One Foot, Now the Other by Tomie de Pado and Annie and the Old One by Miska Miles.

Identify the main ideas from each book. Compare and contrast the characters Alice and Bobby.

What lessons can be learned from each story?

Social Studies



Discuss the lives of famous presidents such as Abe Lincoln.

- Define how history is like memories.
- How does history impact our country?
- Discuss why the memories of Abe Lincoln are so important to us.

Oral Language (speaking)



Orally explain the narrative composition written to the class.

Social Studies and Language



Research the lyrics from "We Didn't Start the Fire" by Billy Joel.

Each student chooses one person or event to write and share a report on.

Written Language



Create a written memory. Write a narrative composition about how it felt to carry out a memory. How did the memory effect other family members?

Why are family memories important in family development?

Culminating Activity

(Health)



Create a memory lesson p. 154

Read Badger's Parting Gifts by Susan Varley

Music



Analyze the lyrics from "Memories" by Barbara Streisand.

Art



Illustrate your favorite memory.

Physical Education

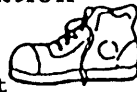

Students always remember a pleasant walk on a sunny afternoon.

Math

- + ÷ × =

- Elementary
- Middle/Junior High
- High School

Create A Memory

Objective

Students will describe the importance of creating healthful and loving family memories.

Life Skill

I will help create healthful and loving memories with family members.

Materials

Pictures of family memories brought in by students

Motivation

- 1** Discuss family memories. A memory is a person or event that is remembered. Ask students to think of five pleasant memories that they have had with their families. Have students select one of these memories to share with the class.
- 2** Have students bring a picture, postcard, or other item to class that is helpful in describing a pleasant memory that they have had with their families. Have students share this memory with classmates.
- 3** Discuss the importance of family memories. They build a closeness between family members. They can be shared after a loved family member has passed away. Memories continue to live on when someone has died.
- 4** Have students think of something they can do this week to create a family memory. They are to be as creative as possible. They can write their plan on a sheet of paper. Their plan should state a step-by-step way to create the memory they desire. Have them volunteer to share their plans with the class.

Evaluation

After the week has passed, have students review the plan they used to create a family memory. Why was it important to create this plan? How did they feel carrying out their plans? How did other family members feel?

MEMORIES

APPENDIX G

THEMATIC INTEGRATED UNIT

THEME: "SELF CONCEPT"

Integrated Planning Tool

Learner Outcome

Grade Level: Grade 5 **Time:** 3 weeks **Theme:** Self-Concept

Strand: Mental/Emotional Health / Consumer Health

Focus/Outcome: To identify their most valuable personal qualities.

To identify media techniques used to advertise and persuade consumer choices.

Assessment

The learner will create a commercial advertising ways individuals improve their self-concept.

The learner will write a biography about their most valuable personal qualities and explain why they are most valuable.

Content/subject area:

Health

Specific Objective:

The learner will evaluate the accuracy of product claims by comparing models in advertising to common everyday people.

The learner will identify their most valuable personal qualities.

Content/subject area:

Reading

Specific Objective:

The learner will describe a character's behavior in a selection.

Content/subject area:

Math

Specific Objective:

The learner will multiply money amounts.

The learner will be able to analyze data in line graphs.

Content/subject area:

Science

Specific Objective:

The learner will create an experiment comparing two brand name products.

Content/subject area:

Language Arts

Specific Objective:

The learner will identify media techniques used in advertising.

The learner will demonstrate in writing the steps to a persuasive paragraph.

Content/subject area:

Specific Objective:

Content/subject area:

Specific Objective:

Content/subject area:

Specific Objective:

Student Reading

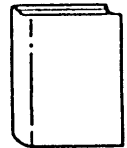

Teacher Read-Alouds (listening)

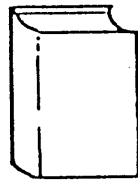

Read Paper Bag Princess by Robert N. Munsch

- How did the Princess feel about herself?
- What characteristics did the prince have?
- How did he feel about the princess?
- What lesson can be learned from this story?

Social Studies



Oral Language (speaking)



Science



Create an experiment comparing two brand name products: (i.e.)

- Two people using two different types of shampoo for a week.
- Write observations.
- Do the most expensive products enhance body image or self concept?

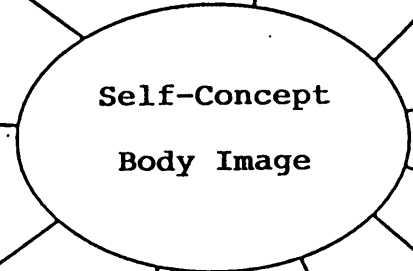

Consumer Health

What a Body Lesson Included in packet.



(Start With This Lesson)

Written Language



After Math and Science lesson is completed, write a persuasion composition as to which product is more for your money.

Culminating Activity

You and Me Game Included in packet.

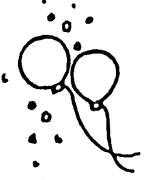

Music



Art



Math - + ÷ × =

Compare prices of brand name products to generic products.

Develop a line graph. Explain which product is more for your money.

WHAT A BODY!

True or False:

1. The average American 13 to 15 years old spends over \$1,000 a year.

▶ 1. True. American teens do spend an average of over \$1,000 per year. That means teens are spending *more than a billion dollars* a year just in New York State.

True or False:

2. Advertisers don't care whether teenagers buy anything.

▶ 2. False. Advertisers care very much about what you buy! They want you to spend your money on the products they sell.

True or False:

3. Advertisers know kids (and adults) want other kids to think they're "cool," and they try to make teens think they'll be "cool" if they buy certain products.

▶ 3. True. Advertisers do research to find out how to sell to you. They try to make you think you'll be "cool" if you wear certain clothes, use certain products, and eat certain foods.

What is the "cool" image that advertising tries to sell to the teenaged market?



Make a collage of magazine pictures, ads, and words that show how advertisers portray women or how advertisers portray men.

List what the women portrayed have in common. Are they tall, thin, young, rich?

List what men in the ads have in common. Are they rich, tall, muscular?

True or False:

1. No one in America is very impressed with a good athlete.

▶ 1. False. Our society puts athletes on a pedestal. We think they're important people.

True or False:

2. Many athletes make lots of money performing their sport or making commercials.

▶ 2. True. Professional athletes can make millions playing their sport. And attractive or interesting sports stars often continue making big bucks by selling products in magazines and on television.

True or False:

3. Most Americans would recognize Mary Lou Retton's name.

▶ 3. True. Mary Lou became America's darling when she won her Olympic Gold Medal. But she's just one of many sports stars who are very well known to the public. We respect sports figures and give them stardom.



Make a collage about sports stars from pictures and words you find in sports magazines. Be sure you include males and females from a wide variety of different sports.

List some ways the bodies of athletes are alike.

List some ways the athletes' bodies are different.

The media affects how we see ourselves and others. We can't help comparing ourselves to people we see in magazines and on television, but most people don't look like fashion models or sports stars. What do real people look like?



True or False:

1. Most real people don't look like fashion models or sports stars.

▶ 1. True. Models and athletes do not have average bodies, and most people don't look like them.

True or False:

2. Advertising and television affect how people think of their own bodies.

▶ 2. True. Even when we know it isn't realistic, most of us still compare ourselves with the people we see in the media.



Think about the *real* people you know: parents, aunts, uncles, brothers, sisters, cousins, teachers, coaches, clerks in stores, friends.

Make a collage of words and pictures that shows how real people look.

Does your real people collage look at all like your advertising collage or your sports star collage?

List some ways it looks like the others.

List some ways it looks different from the others.

Was it difficult to find pictures of "real" people?
Do you think the real people in your collage work as hard at looking good as models and sports stars do?

Human beings come in a wide variety of sizes and shapes. Some are taller; some are shorter. Some have bigger feet; some have smaller feet. some are thinner; some are rounder.

We can't help comparing ourselves to the images portrayed in advertising and in sports, but we cannot forget that those images are not reality.

What should a real person look like? Just like you!

The You and Me Game

Materials: A lunch bag
3 x 5 cards

This game teaches children to appreciate themselves and others.

On the 3 x 5 cards write Me, You, I am special, Everyone, I am good at, I enjoy.

Put the cards in the bag. Pass the bag around the circle of students. Each student picks a card out of the bag.

Me card - compliment themselves
You card - compliment the person on their left
Everyone - compliment the group
I am special - explain why they're special - Give special privilege
I am good at - explain what they're good at.
I enjoy - explain what they enjoy.

Adaptations: Whisper compliments to people on their right and then reverse it.

Adapted from: Self-concept Activities
Mailbox Magazine 1989

APPENDIX H

THEMATIC INTEGRATED UNIT

THEME: "THE HAUNTED IGLOO"

CONSUMER HEALTH AND MENTAL/EMOTIONAL HEALTH

Integrated Planning Tool

Learner Outcome

Grade Level: 5 **Time:** 4 Weeks **Theme:** The Haunted Igloo
Strand: Family Life-Friendship / Mental/Emotional Health - Peer Pressure - Decision Making - Refusal Skills

Focus/Outcome: The learner will explain the influence of peer pressure on behavior. The learner will effectively contribute to group decision making by using the decision-making model. The learner will list the characteristics that help maintain friendships and compare their own characteristics with those on this list. The learner will demonstrate refusal skills.

Assessment

Write and perform a skit or puppet show demonstrating a peer pressure situation where responsible decision making skills and refusal skills are used.

In cooperative partners: create a list of characteristics that help maintain friendships. Construct a Friendship Flowchart from that list. Explain the chart.

Content/subject area:

Reading

Specific Objective:

The learner will recall details about a selection.
 - recall details of plot and setting.
 - predict the outcome of a given selection.

Content/subject area:

Health

Specific Objective:

The learner will identify peer pressure and explain the influence it has on behavior.
 - Using Responsible Decision Making Model, the learner will explain the steps.
 - Demonstrate how to use refusal skills.

Content/subject area:

Health

Specific Objective:

The learner will identify characteristics of true friendship and compare their own characteristics with those on the list.

Content/subject area:

Language

Specific Objective:

The learner will organize information and write a story.
 The learner will understand the process of practicing and presenting a play for an audience.

Content/subject
area:

Social Studies

Specific
Objective:

The learner will compile information about the Northwest Territory in Canada near the Arctic Circle.

Content/subject
area:

Social Studies

Specific
Objective:

The learner will assess cultural similarities and differences of Eskimos in the Arctic (land, climate, religion, history, government, economy and technology.)

Content/subject
area:

Science

Specific
Objective:

The learner will describe and label time zones, climate and temperature of each region in the United States and Canada.

Content/subject
area:

Education
for Employment

Specific
Objective:

The learner will develop questions to discuss with a well-known author about their writing career.

Content/subject
area:

Math

Specific
Objective:

The learner will measure the igloo to have a diameter of 16 and a radius of 8 using a compass. Estimate how many marshmallows it will take to build the igloo.

Content/subject
area:

Art

Specific
Objective:

The learner will design and construct an igloo out of mini-marshmallows.

ACTIVITIES

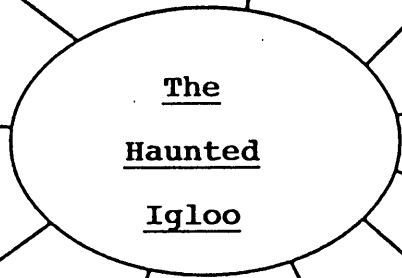

Student Reading



Discuss and recall details about The Haunted Igloo.
 Make predictions while reading the story.
 Identify plot, setting, high point of each chapter.
 Identify main idea of each chapter.

Teacher Read-Alouds (listening)



Read The Haunted Igloo by Bonnie Turner
 One or two chapters a day.
 Introduce Eskimo vocabulary.

Social Studies



Discuss and study Eskimo culture in the Northwest Territory (land, climate, religion, history, etc).
 In cooperative groups design a book illustrating and writing about Eskimos in the Arctic.

Oral Language (speaking)



Perform a skit or puppet show demonstrating peer pressure and friendship.
 Study Drama Chapter 28 in the Language Text. McDougal, Littell Building English Skills Silver Level
 Build an understanding of script writing, directing, staging, props, etc.

Science



Study climate, temperature and time zones of the United States. Compare similarities and differences in the Arctic.
 Why is it dark and cold most of the time?

Education for Employment



Invite the author Bonnie Turner to visit with the class. Develop questions to ask her prior to her visit.

Written Language



Using the Responsible Decision-Making Model & refusal skills (in packet) re-write the section of the book where Jean Paul made his decision to be in the Ice Patrol and to go into the Haunted Igloo.
 After Marshmallow igloo is constructed write a story about your igloo.

Culminating Activity

Health/Peer Pressure/Decision Making

Do Temptation Activity (in packet). Then Discuss Jean-Paul's experiences with peer pressure. How did peer pressure get him into trouble?
 - Was Chinook a true friend?
 - Peer pressure & acceptance
 - How did Chinook change?
 - What lessons did Jean-Paul learn about decision making and friendship?
 - Why was Sasha Jean-Paul's best friend?



First Aide and Safety

Discuss prevention of frostbite. Treatment of frostbite.

Art - Math



Design & construct a marshmallow igloo in cooperative groups to have a diameter of 16 & a radius of 8. Estimate number of marshmallows used to build the igloo.

Health Family Life Friendship

Discuss the Guidelines For Friendship and friendship flowchart included in packet
 - Construct a friendship flowchart.

Temptation

Objective

Students will identify ways to avoid being tempted to become involved in risk behaviors and risk situations when pressured by peers.

Life Skill

I will say NO when pressured by peers to engage in risk behaviors and risk situations.

Materials

Tootsie Roll for each student

Motivation

- 1** Use the following demonstration to illustrate peer pressure to your students. Divide the class into three groups. The first group is the risk behavior group. Explain that a risk behavior is an action that might be harmful to you or others. Give each person in the risk behavior group a Tootsie Roll. The second group is the risk situation group. Explain that a risk situation is a situation in which another person's behavior threatens your health. Give the risk situation group a Tootsie Roll. The third group is the healthful behavior group. This group does not get a Tootsie Roll.
- 2** Now explain peer pressure. Peer pressure is the influence persons your age use to encourage you to make the decisions they want you to make. Explain that the first group is to eat one of their Tootsie Rolls in front of the second while they encourage the second group to do the same. They are to be as convincing as possible to the second group. After several minutes, stop to see if anyone in group two ate a Tootsie Roll. Discuss the kinds of reasons that group one used to pressure group two.
- 3** Now have the students in group two who did not eat their Tootsie Roll, unwrap it, and take a small bite. Then they are to hold the remaining part of the Tootsie Roll in their hand near their mouth without eating it. Again, group one is to pressure group two to eat the Tootsie Roll. After several minutes, stop and ask persons in group two if they were more tempted to eat the Tootsie Roll before they unwrapped it or after they had unwrapped it and taken a small bite.

4 Take aside group three so that groups one and two will not hear the directions that you are going to give them. Tell group three to say "NO, I do not want to eat the Tootsie Roll" each time they are pressured. They are not to touch the Tootsie Roll. After they are pressured three times, they are to move away from the person offering them the Tootsie Roll. Now give groups one and two Tootsie Rolls that they can offer group three. Instruct them to pressure group three to try to eat the Tootsie Rolls.

5 Discuss the results of this experiment. When group one pressured group two, what convincing techniques were used? After persons in group two unwrapped their Tootsie Rolls and took a bite, was it more tempting to continue eating the Tootsie Roll? Explain that it usually is. This is why limits need to be set on most behaviors to avoid easily doing something you previously said you would not do. For example, taking a sip of a beer may lead to drinking, taking a puff of a cigarette may lead to smoking, and petting may lead to sexual intercourse. Discuss group three. Group three avoided the risk behavior by firmly saying "NO." But this group also avoided being tempted. No one touched the Tootsie Roll. Group members got away from the risk situation.

Evaluation

Have students define peer pressure, risk behaviors, and risk situations. Have students tell ways to avoid engaging in risk behaviors and risk situations.

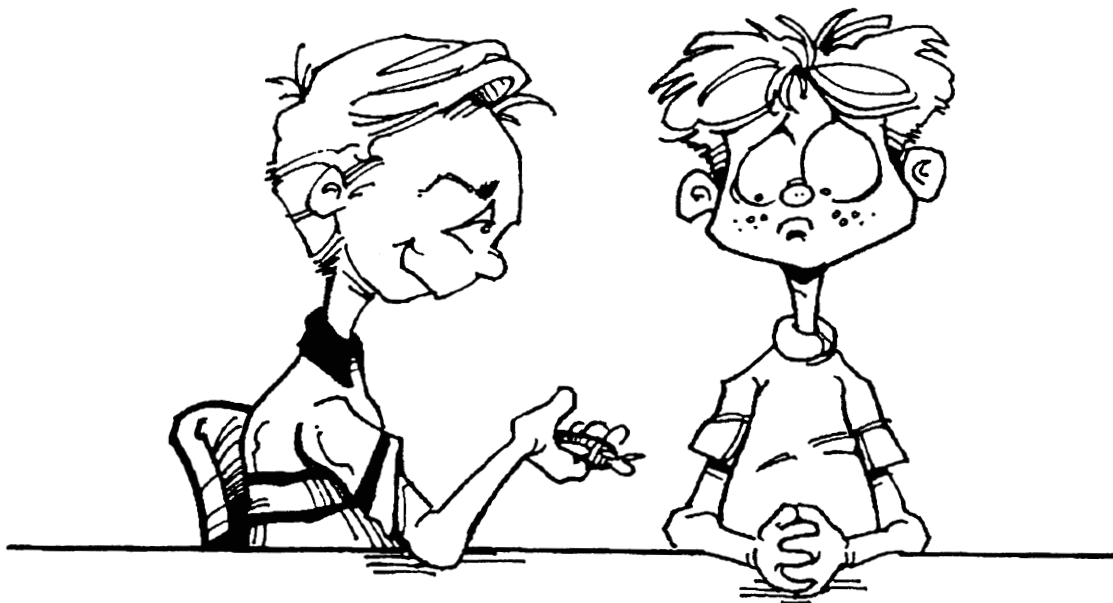

Responsible Decision-Making Model

105

1. Identify the situation about which a decision must be made.

2. Identify the different choices you may make.

3. Ask questions about each possible choice.
 - Would the results of my decision be healthful?
 - Would the results of my decision be safe?
 - Would the results of my decision be legal?
 - Would the results of my decision show respect for myself and others?
 - Would the results of my decision follow my parents' or guardian's guidelines?

4. Make a responsible decision.

5. Check to see that the decision resulted in responsible behavior.

FLOWCHART

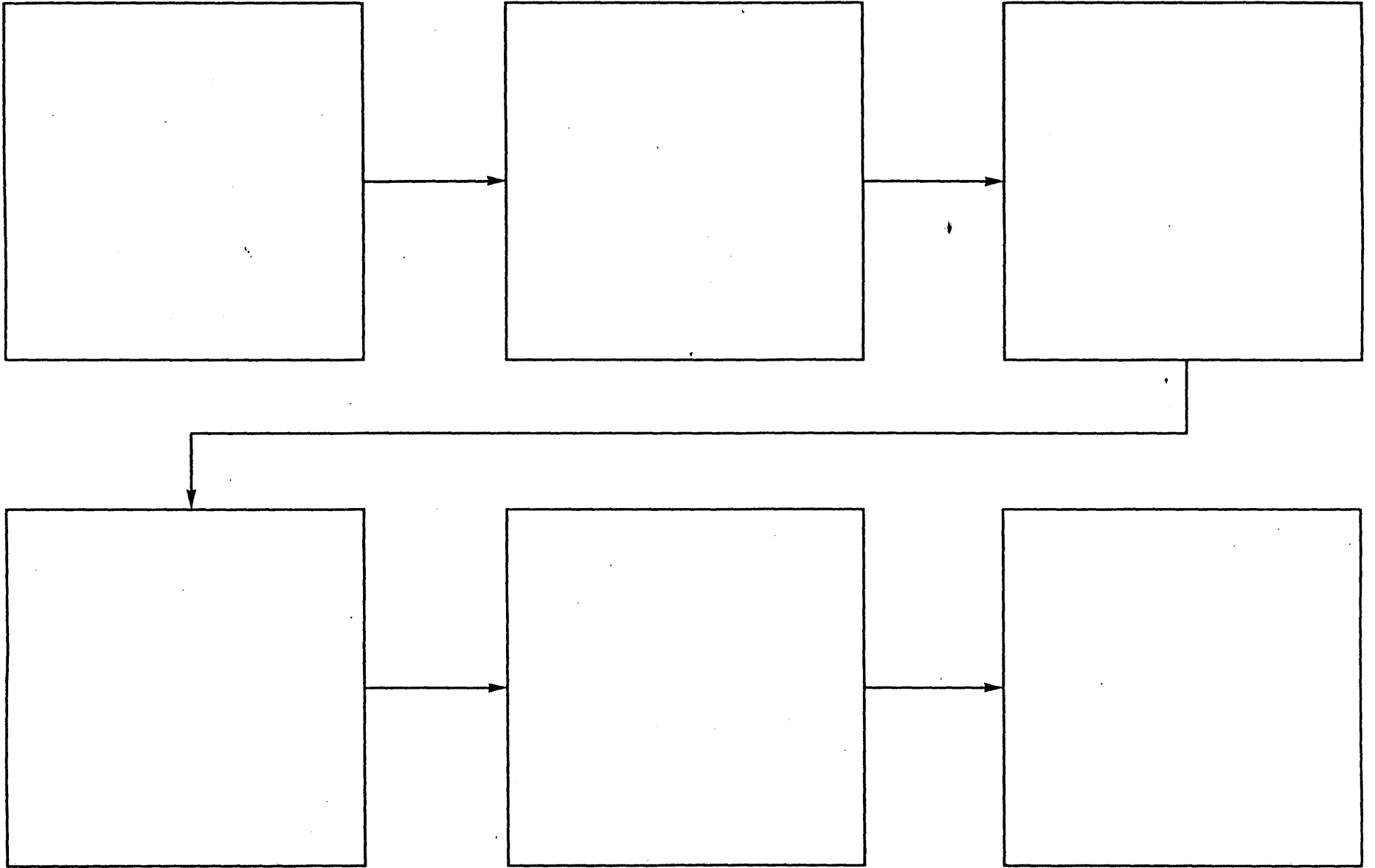

Name _____

Characters: _____

Setting: _____

Problem: _____

Turning Point: _____

Solution: _____

Are You a Healthful and Responsible

FRIEND?

How would you rate yourself
on each of these guidelines?

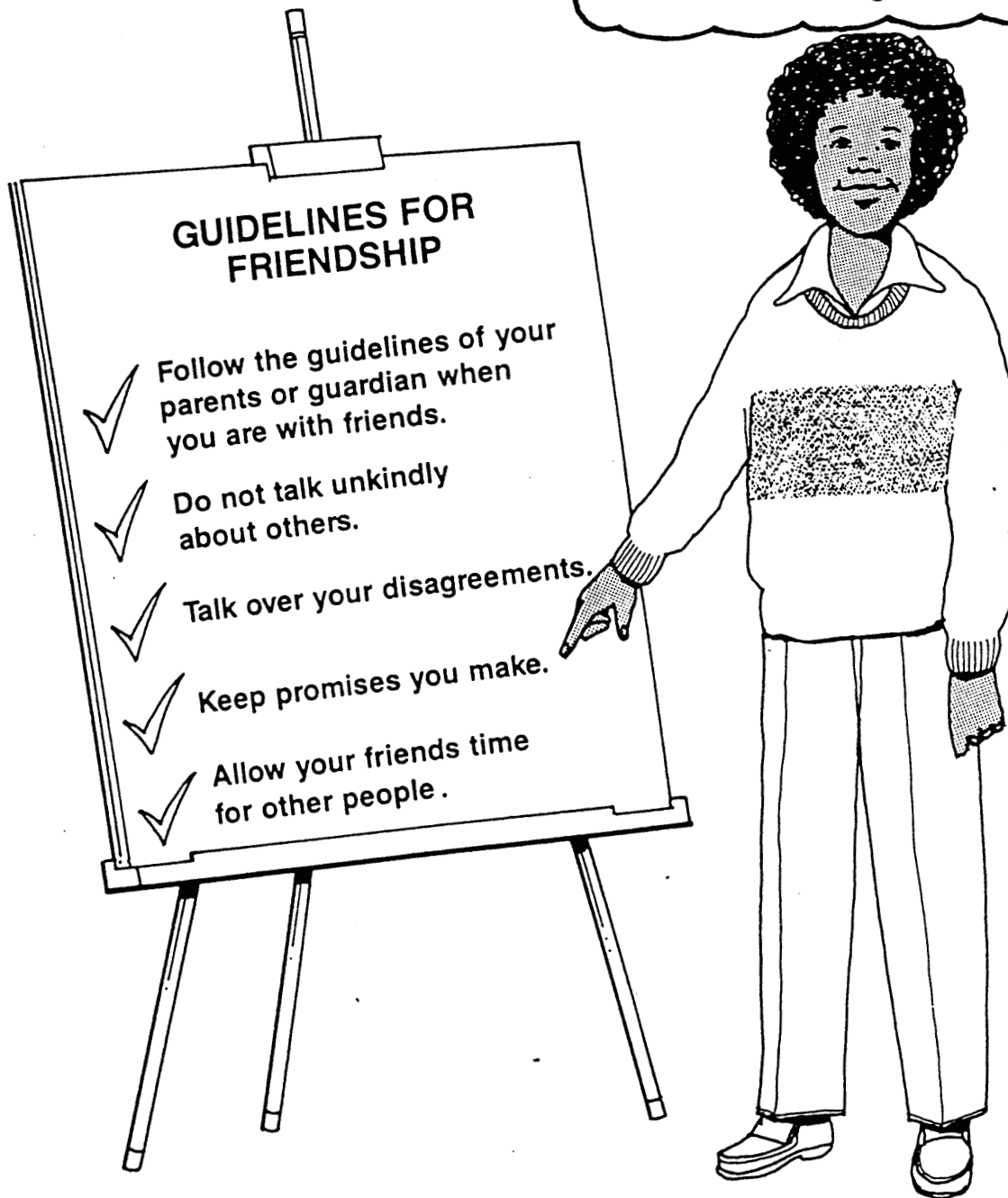

Story clues: _____

+

Experience clues: _____

=

My prediction: _____

Was my prediction correct?
Yes, _____

No, instead I learned that _____

SEMANTIC MAP

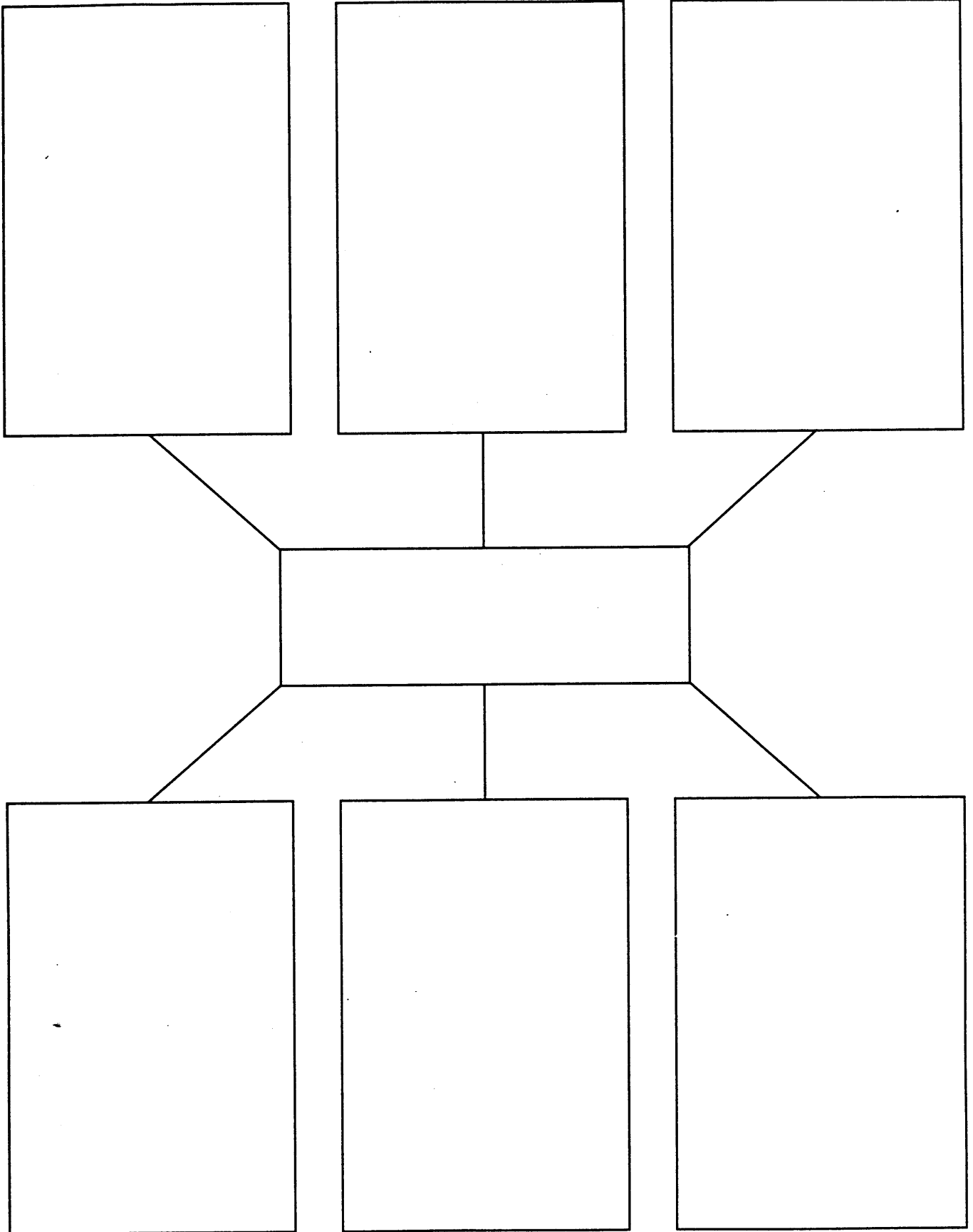

APPENDIX I

THEMATIC INTEGRATED UNIT

THEME: "HAPPINESS"

MENTAL/EMOTIONAL HEALTH

Integrated Planning Tool

Learner Outcome

Grade Level: Grade 5 **Time:** 3-4 Weeks **Theme:** Happiness

Strand: Mental/Emotional Health

Focus/Outcome: To describe the basic emotional needs needed throughout the life-cycle.
To label and identify the three essentials for happiness.

Assessment

The students will create a large triangular collage that identifies the three essentials of happiness. They will include personal pictures that show those essentials; someone to love; something to hope for; something to do.

Students will write a composition titled "Happiness Is My Choice" and explain that theme by relating it to the three essentials of happiness.

Students will prepare a 5 minute speech explaining their triangular collage and their composition.

Content/subject area:

Language

Specific Objective:

The learner will apply the 5 steps of the writing process writing an expository composition.
The learner will participate in giving a 5 minute speech.

Content/subject area:

Math

Specific Objective:

The learner will find the perimeter of a polygon.
The learner will identify lines of symmetry.

Content/subject area:

Reading

Specific Objective:

The learner will identify the use of narrative in a selection and the author's purpose for its use.
The learner will construct a ven diagram.

Content/subject area:

Social Studies

Specific Objective:

The learner will describe frontier life before and after pioneers arrived.
The learner will compare pioneer life to modern day life.

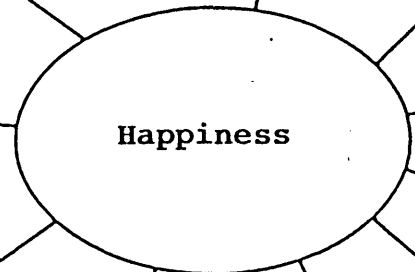

Student Reading

Read Sarah, Plain and Tall by Patricia MacLachlan

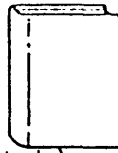

Discuss vocabulary, author's purpose (could lead to an author's study), narrative selection (characteristics of narratives). Construct a ven diagram comparing similarities and differences of Sarah to Laura Ingalls Wilder.

Teacher Read-Alouds (listening)

Laura Ingalls Wilder Books



Compare and contrast life long ago with life now. What would her Happiness Triangle include? Construct a Laura Ingalls Wilder Happiness Triangle

Social Studies



Read and discuss the chapter in the text on pioneer life.

Compare pioneer life to the three essentials of happiness triangle. Discuss pioneer life compared to modern day life.

Oral Language (speaking)



Prepare and present a 5 minute summary speech on Happiness using the Happiness Triangle and their composition titled "Happiness is My Choice".

Science



Written Language



Write an expository composition titled, "Happiness is My Choice"

Culminating Activity

Wrap up the Unit by discussing the three main things the students felt they got out of the Unit.



Play the song "Don't Worry, Be Happy"

(Could also be used as a lead in to the next unit on stress and stress management.)

Music

Song "Don't Worry Be Happy"

Art



Construct a covered wagon using paper, toothpicks, and glue (pattern in packet)

Physical Education



Math

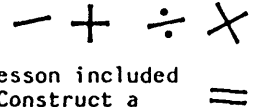

"Build it" (lesson included in packet). Construct a pyramid. Explain and label the pyramid of life.

Make a polygon mobile. Measure and label the perimeter of each polygon in the class. (Chart the measurements)

- Elementary
- Middle/Junior High
- High School

"Don't Worry, Be Happy!"

Objective

Students will identify the three essentials for happiness and will tell actions they can take to promote happiness in their lives.

Life Skill

I will work hard, spend time with friends, and set goals for happiness.

Materials

Recording of the song, "Don't worry, Be happy," tape recorder, disc or cassette player for music, poster paper, scissors, magazines, glue

Motivation

- 1** Write the following statement on the chalkboard. Joseph Addison said, "The three grand essentials to happiness are something to do, someone to love, and something to hope for." Then make a triangle on the chalkboard and write each of these at one of the points: something to do, someone to love, something to hope for. In the middle, write happiness.
- 2** Discuss happiness with students. Explain that happiness often involves choice. Each of us has control over happiness because we can choose to do things which promote happiness. Discuss each of the three points on the triangle. Having something to do promotes happiness. Give examples: playing on a sports team, having a hobby, volunteering to help others. Having someone to love promotes happiness. Give examples: spending time with family, having a close friend, having a pet. Having something to look forward to promotes happiness. Give examples: graduation from high school, a summer vacation, religion which gives meaning to the future.
- 3** Have students make a collage of happiness. On posterboard, they are to draw a large triangle. Then at the three points of the triangle, they can write: something to do, someone to love, something to hope for. They are to cut out pictures or draw pictures to represent these three areas. They may want to attach a picture of someone about whom they care near the point which says, "someone to love." While they are making their posters, you might play a recording of the song "Don't worry, be happy."

- 4 Have students share their completed posters explaining their choices for happiness in the three areas.
- 5 Referring back to the triangle, explain how these three areas give balance to life. Discuss what would happen if one side of the triangle were removed, the triangle would collapse. What happens to happiness when a person neglects one of these areas?

Evaluation

Have students write a short paper titled, "Happiness is my choice."

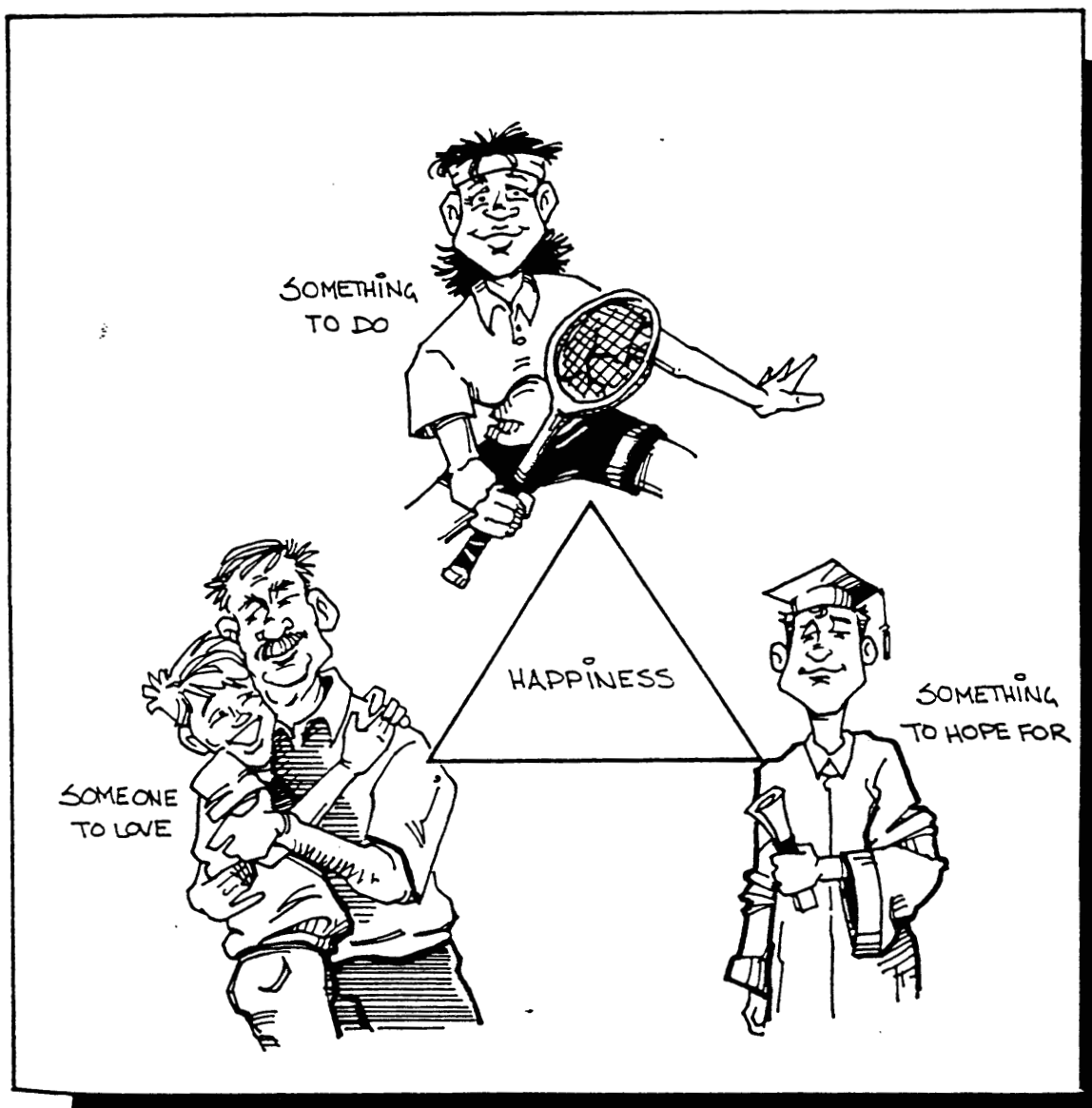

VENN DIAGRAM

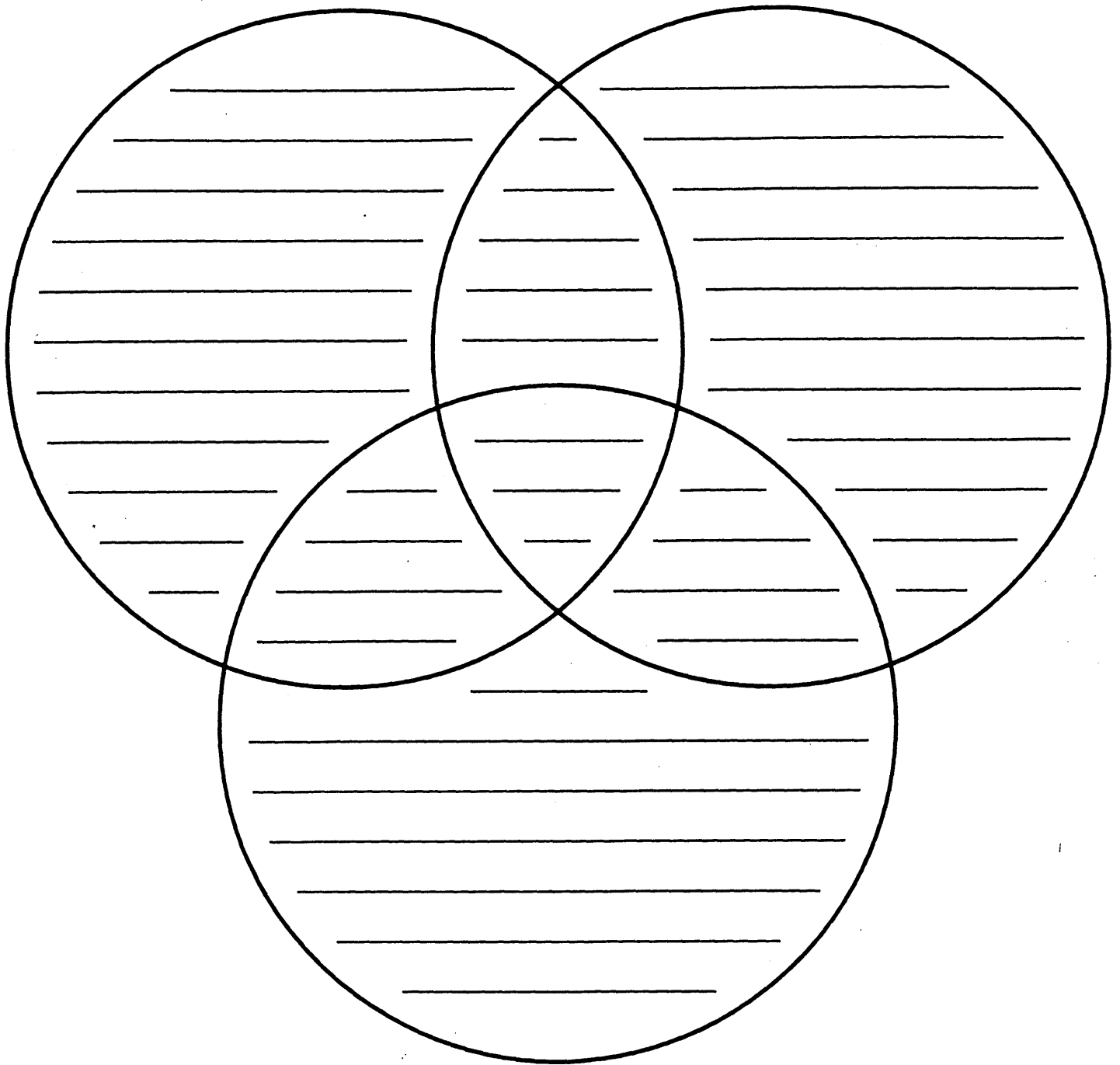

Name _____

Title: _____

Author: _____

Setting: _____

Characters: _____

Place: _____

Time: _____

Problem: _____

Events: _____

1. _____

2. _____

3. _____

4. _____

5. _____

Name _____

Resolution: _____

Great Explorations

Activity File

Options for Launching Objectives 137, 144, and 188

A Use before Objective 137

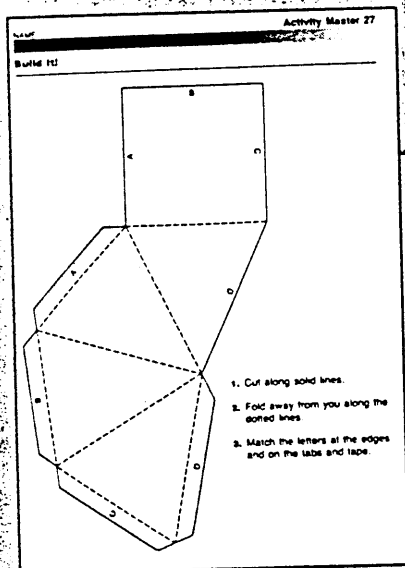

Activity Master 27

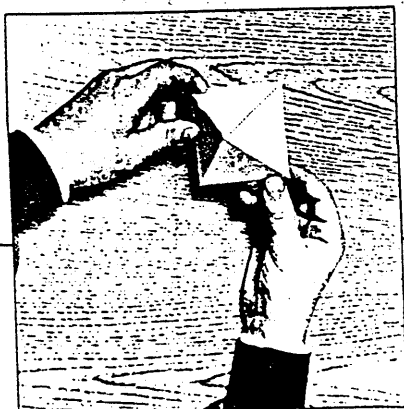
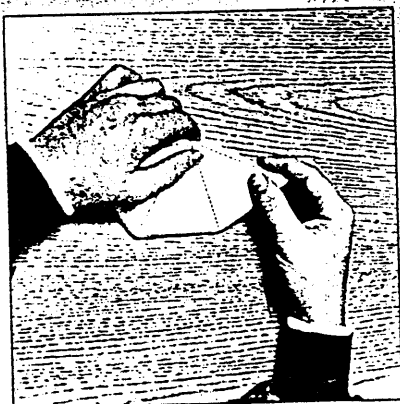

Build It!

Constructing a pyramid

Materials Activity Master 27, scissors, tape

Launch the Activity Provide each student with a copy of Activity Master 27, a pair of scissors, and some tape. Explain that students will be using these materials to make a solid figure.

Guide the Activity Ask students to cut out the pattern on the activity master. Then have students fold along each of the dotted lines, starting at the bottom of the pattern and working toward the top. Next, have students construct the pyramid by matching edges and tabs with the same letter and taping them together. Have students begin by matching edges and tabs labeled A, then B, and so on.

Discuss Result Ask students what solid shape they have formed [Pyramid] If no one knows, supply the name. Ask students how many surfaces the pyramid has. [5 surfaces] Explain that surfaces of a solid shape are called *faces*. Then ask students if all the faces are the same shape. [No] Have them identify the shapes of the faces and count the number of each. [1 square, 4 triangles] Finally have students count the number of edges and the number of points. [8 edges, 5 points]

Stretch Their Thinking Ask students to name familiar objects that have the same shape as a pyramid. [Samples: A tent, the top of a building, the Great Pyramid]



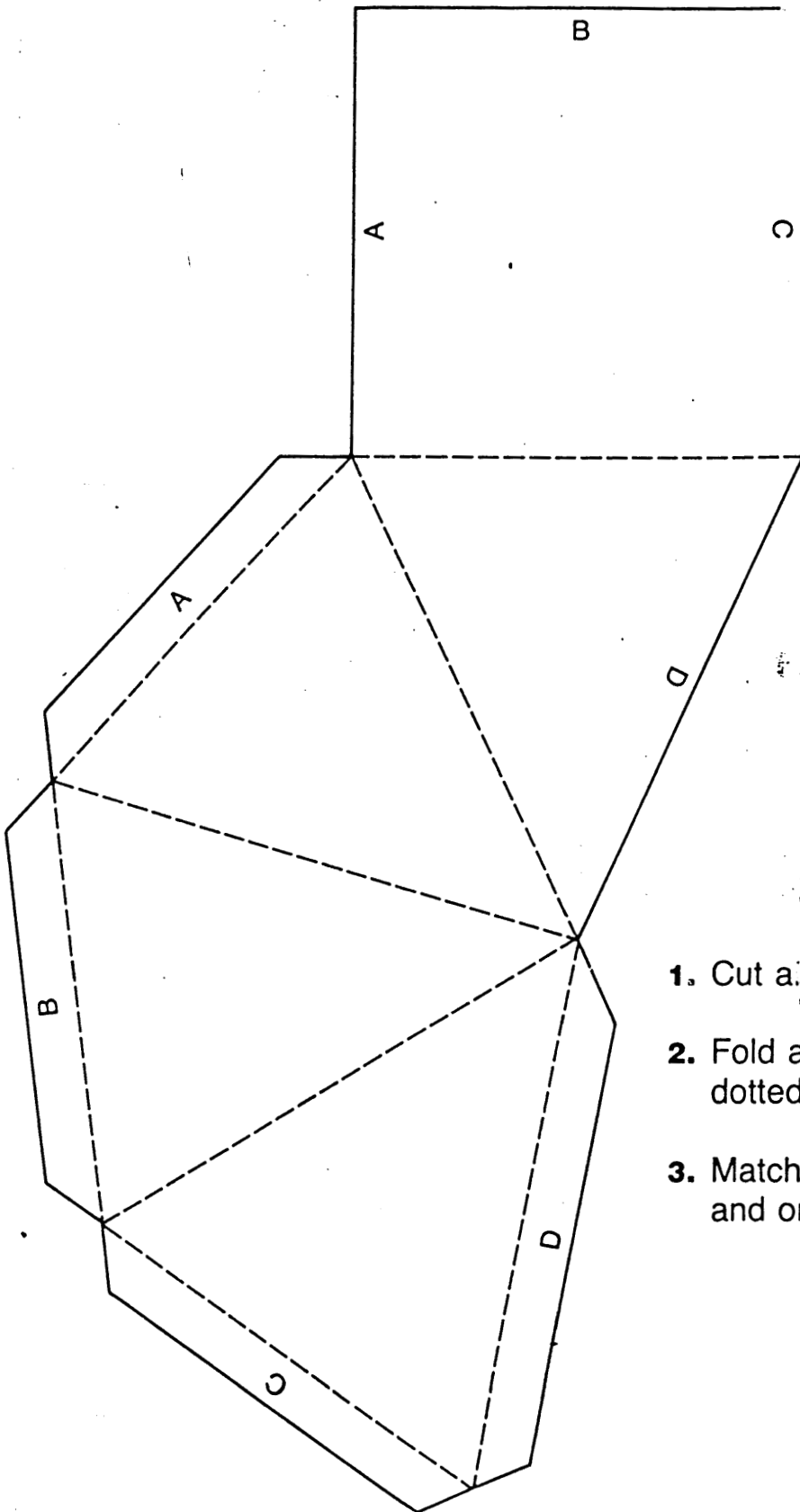

1. Cut along solid lines.
2. Fold away from you along the dotted lines.
3. Match the letters at the edges and on the tabs and tape

APPENDIX J

THEMATIC INTEGRATED UNIT

THEME: "RISKY BEHAVIORS"

SUBSTANCE USE AND ABUSE

HIV/AIDS

Integrated Planning Tool

Learner Outcome

Grade Level: 5 **Time:** 2-4 Weeks **Theme:** Risky Behaviors

Strand: Prevention and Control of Disease
 Substance Use and Abuse

Focus/Outcome: The learner will explain the process of communicable disease transmission.
 The learner will explain that avoidance of risky behaviors will protect them from HIV/AIDS.
 The learner will practice decision-making skills about drugs and alcohol.

Assessment

The learner will complete the AIDS Awareness Survey, choose one question, and develop a two-three paragraph explaining about the chosen question. Including avoidance of risky behavior and the impact of drugs, alcohol, and risky behaviors and decision-making.

Content/subject area:

Reading

Specific Objective:

The learner will identify kinds of information in a newspaper and on television.
 The learner will recognize cause and effect relationships.

Content/subject area:

Health
AIDS/HIV

Specific Objective:

The learner will identify that HIV/AIDS attacks the immune system.
 The learner will explain the risky behaviors that cause HIV/AIDS.

Content/subject area:

Health
Substance Abuse

Specific Objective:

The learner will make decisions about using drugs and alcohol.
 The learner will identify the community and family impact of drug and alcohol abuse.

Content/subject area:

Language

Specific Objective:

The learner will write a newspaper article and identify the who, what, where, and when of the article.

**Content/subject
area:**

Social Studies

**Specific
Objective:**

The learner will describe the change in American attitudes from World War II to modern days.

The learner will identify the causes and effects of the cold war.

**Content/subject
area:**

Math

**Specific
Objective:**

The learner will estimate quotients using rounding.

- Find an average
- Write a probability ratio for a situation involving equally likely events.

**Content/subject
area:**

**Specific
Objective:**

**Content/subject
area:**

**Specific
Objective:**

ACTIVITIES

Discuss: What Are Risky Behaviors? Start with activity Temptation p. 180 (in packet)

126



Student Reading



Collect newspaper articles on HIV/AIDS, Drunk Driving, Drug Abuse or any other article related to people participating in risky behaviors.
Also keep a journal on media coverage, advertisement or daily conversation related to the same topics.
- Identify cause and effect relationships from the articles and journal writings.

Teacher Read-Alouds (listening)

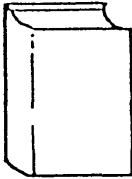

Read Friends For Life from the Kids on the Block series.
The book clearly covers causes of HIV/AIDS, Qualities of Friends, and treatment of people diagnosed with HIV/AIDS in a story selection geared to children of upper elementary grades.



Social Studies Unit 14
"A Modern Nation" U.S. Past & Present
Heath 1990.

Read and discuss the lessons on World War II and changing American attitudes and the lesson on the Cold War.
Do talents lesson #5 (included in packet)
- Use as a lead in to the current war on drugs. Discuss causes and effect of drugs on our society.

Oral Language (speaking) and Ed. for Employment

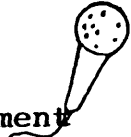

In cooperative groups formulate a news team.
Each day one news team will share news developed from newspaper articles and journals.
News team must include a story about something positive, such as teens helping teens, etc.

Science - Health



Explain AIDS and the Immune System. Use handout in packet. Watch Slim Goodbody; The Immune System.
- Using two brown lunch bags, demonstrate the effect of HIV on the Immune System. (Directions in packet)

Risky Behaviors

Physical Education and Health

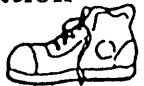

Discuss the importance of exercise and keeping your body strong.
Watch the video, "A Conversation with Magic Johnson".

Written Language



Write a newspaper article about a person engaging in risky behaviors.
Use a make-believe name. Identify the who, what, where, when in the article.

Culminating Activity

Saucer Game (Directions in packet)

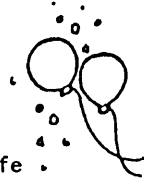

Use as intro to unit on family life and the role each family member has on the development of the family.

Music

Write a rap song about avoiding risky behaviors.

Art



Design and construct a stage set from where the news team reports. (e.g. a large TV out of cardboard, a backdrop painted to resemble a newsroom.)

Math - + ÷ × =

After the study of rounding and averaging, numbers, estimate the amount drug abuse has cost our nation. Write a probability ratio between a community avoiding risky behaviors and one engaging in risky behaviors.

MAKING GOOD DECISIONS

It's easier to make good decisions if you have all the information you need and understand the choices open to you. Think of a situation that could happen this afternoon or this evening in which you must make a decision. Complete the worksheet below, then make your choice. Tomorrow, evaluate your choice.

1. IDENTIFY THE PROBLEM. _____

2. DECIDE WHAT YOU WANT TO ACCOMPLISH. _____

3. ANALYZE YOUR CHOICES AND POSSIBLE RESULTS.

POSSIBLE CHOICES:

RESULTS:

4. CHOOSE THE BEST ALTERNATIVE. _____

5. TONIGHT, ACT ON YOUR CHOICE.

***** STOP HERE UNTIL TOMORROW *****

6. EVALUATE AND ACCEPT THE RESULTS. _____

AIDS And The Immune System

4. As a result, a person no longer has resistance to life-threatening infections.

3. When T Cells are destroyed, the immune system can no longer attack and destroy pathogens.

Reproduction of the AIDS virus

2. When the AIDS virus invades the body, it attacks the infection-fighting T cells.

T-lymphocyte, a type of white blood cell

1. Our immune system constantly produces cells and antibodies that destroy pathogens to which we are exposed everyday.

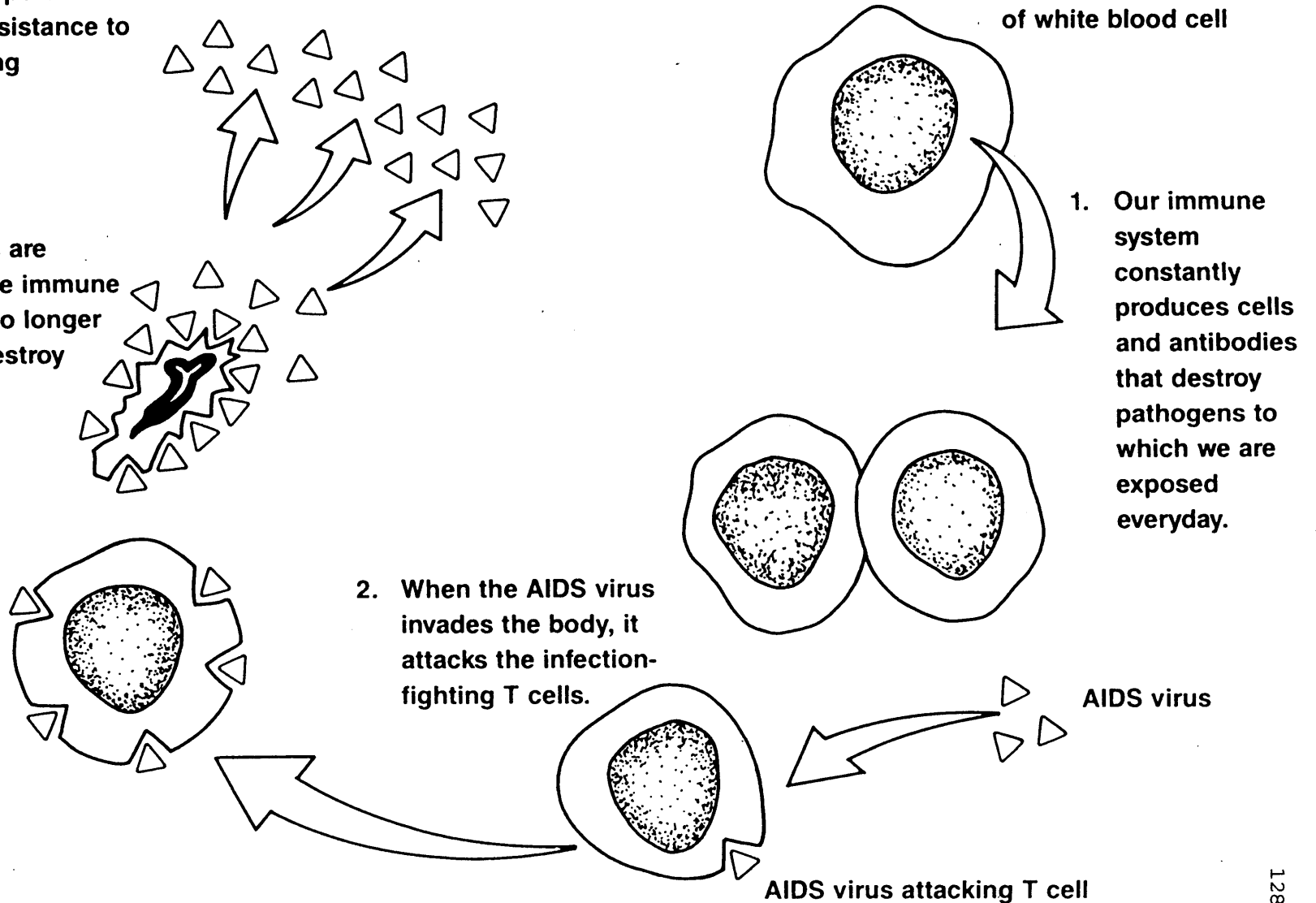

AIDS Awareness



1. When I think of AIDS, I think of _____

2. When and where did you first learn about AIDS?
when _____
where _____

3. How would you feel if you found out that you had become infected with the AIDS virus?

4. What do you feel are some of the worst complications which can result from infection with the AIDS virus?

5. Why do persons with AIDS need compassion and understanding?

6. Since AIDS is preventable, why are so many people infected? _____

7. More people would know about and what to do about AIDS if we _____

8. Things about AIDS that I would like to know more about are: _____

Cindy Short
July 1, 1991
Health Education 712
Dr. Oganowski

ACTIVITY PLAN - "IDEAS WORTH DOING"

TOPIC: Drug Education

RECOMMENDED GRADE: 4-6

GOAL: To understand the impact of alcohol abuse on the family unit.

BEHAVIORAL OBJECTIVES: 1. The students will be able to identify ways that alcohol abuse impacts a family.

2. The students will participate in a discussion of possible solutions to the problem.

MATERIALS NECESSARY: plates, frisbees, discs, or a similar material
masking tape or string

RESOURCES: Game - The New Games Book, p. 127.

Worksheet - Loving, p. 25
A Good Apple Activity Book for Grades 3-8
By Mary Anne McElmurry, O.P.
Good Apple, Inc., Box 299
Carthage, IL 62321

DESCRIPTION OF ACTIVITY:

1. Begin lesson by discussing families and how they help each other. Make a list of some of the tasks that families do together.
2. Ask for some volunteers to be part of a family. Explain that this "family" is going to solve a problem together by playing a game.
3. Introduce the game Islands taken from p. 127 of The New Games Book. The game is played as follows:
 - a. The group is given a set of plates, frisbees, discs or some similar material.
 - b. Mark off the starting line and the finishing line.

- c. Using the plates the group has to get from the starting line to the finishing line. They need to figure out a strategy for laying down the plates and how they will get across while observing the following rule.
 - d. No plate may be left unoccupied or it will be taken away.
 - e. Give the group time to figure out a strategy and then let them attempt to solve the problem.
4. Once the family has successfully solved the problem, discuss the ways in which they helped each other.
 5. Using the same game, introduce a new family member who has an alcohol problem. I would have the teacher play this role so that the message remains a serious one. Join the group and deliberately make mistakes so that it will be impossible for the group to complete the task.
 6. Discuss how the structure of the family changed. How did the alcohol impaired family member affect the rest of the family?
 7. Go back to the list of things that families do together and discuss how these activities might change if a member of the family has an alcohol problem.
 8. Be sure to discuss how all members of a family are affected by the alcohol problem of one member.
 9. Continue with a discussion or review of the 3 C's of alcohol abuse for children. The child didn't cause the problem, they can't control the problem or cure it. Only the person with the alcohol problem can control or stop it.
 10. Conclude by having the students develop a list of coping strategies for the family.
 11. Attached worksheet may be used as a supplementary activity.

Writing a Newspaper Article

Remember that a newspaper article gives brief, exact information about a current event.

A. Imagine that you are a reporter for the *China Daily News*. The editor of the newspaper tells you to write the front-page story of the emperor's capture. To help you gather the information you need to write the article, answer the following questions.

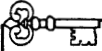
 The **lead** is the first paragraph, and it answers the WH-questions.

- 1. Who captured the emperor? _____
- 2. When and where did it happen? _____

- 3. Why did it happen? _____
- 4. How did it happen? _____

B. Now write the newspaper article. Write the lead, answering the WH-questions. Then, include any other information you have in a second paragraph. When you have finished, write a headline for your article. The headline should state the main idea of the story and capture the reader's attention.

(Headline) _____

Writing a Newspaper Article

A newspaper article gives brief, exact information about a current event. The lead, the first sentence, should contain the most important WH-facts. The body of the article is made up of the details. The headline should contain key words or ideas from the lead.

Use information from the following paragraph to write a news article.

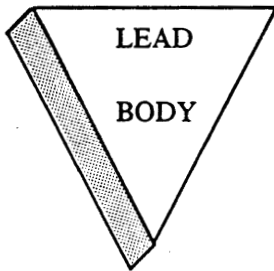

It is the summer of 1814. British forces have just marched through Washington, D.C., and burned much of the city, including the White House. The editor of the local newspaper sends you out to cover the story of the burning of the president's house. Write your newspaper article. Use additional paper, if necessary.

 A newspaper article does not include opinions or the pronouns *I* and *you*.

Did you include a headline?
 Does the lead contain the most important WH-facts?
 Does the body tell more details such as *how* and *why*?

TEACHING IDEAS

HIV/AIDS

AIDS/HIV Teaching Ideas

Barbara Beier, J. Leslie Oganowski, Richard A. Detert, and Kenneth Becker

AIDS/HIV education is essential for the understanding and prevention of the disease. AIDS/HIV is a complex issue and thus demands a multifaceted approach. The condition may be viewed as a disease issue, a decision-making issue, a sexuality issue, and a death and dying issue.

A series of four teaching ideas are presented as they address each of the AIDS/HIV issues. The teaching techniques are as follows:

1. "Understanding AIDS/HIV" — a disease issue
2. "Who Do You Trust?" — a decision-making issue
3. "A Safer Sex Continuum" — a sexuality issue
4. "The Living Years" — a death and dying issue

ACTIVITY #1: "UNDERSTANDING AIDS/HIV"

Objective: After the bag demonstration, the student will be able to describe how HIV breaks down the immune system to allow the development of AIDS.

Preparation: Prepare envelopes for each student with the following shapes representing parts of the blood involved in the immune system. Place the HIV in only three of the envelopes.

T-cells

white
blood cells

B
cells

HIV

Necessary Materials:

- 1 lunch size paper bag for each student
- 2 lunch size bags for teacher demonstration
- markers or crayons
- prepared envelope for each student

Activity:

1. Instruct the students to color or decorate their bag to represent the skin.
2. Review the steps that take place when a germ enters the body by having each student put parts of the blood (from their envelope) in the bag. The teacher demonstrates by placing in the bag each cell type and explaining the action; i.e., white blood cells rush to the place where germs enter and attach to the germ to make it less dangerous to the person.
3. Introduce the functions of the immune system. A healthy immune system works to destroy nearly all types of germs, including many bacteria and viruses.
4. Write "immune" on the board. Have a student tell what is meant when someone says he/she is "immune" to something (protected/safe).
5. Conduct the following demonstration
 - a. Hold two bags to represent the skin as a barrier to keep germs out. As long as

the skin remains uninjured, it holds what's inside the body in and keeps the rest safely out.

b. Reveal a break in the skin by tearing part of one bag. Have students name ways a break could occur (cuts, scratches, burns, scrapes, broken bones, surgery, intravenous drugs, ear piercing, tattoos, punctures).

c. Toss some objects into the bags representing foreign bacteria, viruses, or germs. Explain that our blood contains white blood cells that fight germs. One kind of white blood cell (macrophage) moves through the blood and tissues to surround and "eat" germs. Toss some macrophage cells into the bag.

d. T-cells are another type of white blood cell that help fight germs. T-cells attack and destroy viruses. Add T-cells to the bag. Stress that some T-cells serve as "command centers" for the body's battle against germs.

e. Another kind of white blood cell is called a B-cell. Add the B-cells to the bag. B-cells produce chemicals called antibodies. Explain that antibodies can destroy viruses and other germs.

f. Explain that some antibodies, even after destroying some germs, stay in the body to protect in case there is another exposure to the same type of germ. That is immunity.

Barbara Beier, J. Leslie Oganowski, Richard A. Detert, and Kenneth Becker are members of the faculty at the University of Wisconsin-LaCrosse.

g. Ask students "What happens when the 'command center' in a real battle is destroyed?" Conclude that when germs attack the white blood cells (T-cells) that control the body's immune system, they can cripple the body's ability to fight off infection and disease.

h. Ask who has an "H" in his/her envelope. Toss the "H" into the bag. This represents an HIV condition. AIDS is caused by a virus called HIV (human immunodeficiency virus). HIV destroys the "command centers" (T-cells) of the immune system and the body cannot fight off certain infections.

i. The person with HIV does not usually die of HIV infection directly—the person with AIDS usually dies from other diseases that the body can no longer fight off.

Time Frame: The bag activity itself can be completed in a 30-40 minute class period. The preparatory information could take one class prior to the activity. Questions about symptoms of HIV, children with HIV, and feelings associated with having an "H" in his/her bag could take varying amounts of time.

Do discuss with the class the chances of "having an HIV in his/her bag" and the risks of infection. Include a discussion of caring for the feelings of people who are infected.

ACTIVITY #2: "WHO DO YOU TRUST?"

Objective: At the completion of this activity, students will be able to discuss the benefits and consequences of taking risks.

Preparation: Before students enter the room, the teacher places objects inside each of four large brown paper bags: (bag #1 = one mouse trap that is not set; bag #2 = one small mouse trap that is set; bag #3 = one large rat trap that is set; bag #4 = one block of wood).

There is one block of wood on the corner of the table.

Necessary Materials:

- 4 large brown paper bags numbered 1 to 4
- 2 mouse traps
- 1 large rat trap
- 2 blocks of wood
- table

Activity:

1. Ask for three volunteers to come forward who are willing to take a risk. Describe the risk as selecting one of the paper bags. Volunteers will be asked to blindly reach to the bottom of the bag and grab whatever is in it. If it is the block of wood like the one on the corner of the table, they will receive a designated amount of money.

2. Ask for three volunteers who will assist the risk takers in their adventure. Instruct these volunteers to move to the other side of the room.

3. One at a time, ask each of the three assistants to open each of the bags and look at the contents. Ask them to be expressionless as they view each of the bags. Then ask each of the assistants if there is a block of wood in at least one of the bags. Once verified, ask (one at a time) if he/she would be willing to take the risk of reaching blindly into one of the bags. Some will say no; some, yes.

4. Ask each assistant to meet a risk taker and quietly whisper in his/her ear what was seen in the bags. Then instruct the risk taker to whisper the same message to one other person in the room. Once all three have additional information about the contents, ask each of the risk takers if he/she is still willing to take the risk. Those who say "no" can be seated; those who are still willing to continue remain standing.

5. Provide some more information to the risk takers (and the rest of the class) by revealing the contents of bag #1. Then reveal the contents of bag #2 by unsetting the mouse trap with a folded piece of paper. Ask again which risk takers would still be willing to blindly reach into one of the two remaining bags.

6. Ask the assistants to provide a bit more information to the risk takers and

the rest of the class by asking whether a consequence of reaching into one of the bags could result in a) pain, b) broken fingers, or c) the presence of blood? Then ask again who might be willing to take the risk.

7. Teacher places remaining risk takers in the front of the room and asks them one more time if they are willing to take the risk. If yes, mix the bags up and ask the risk takers to turn around. By now, most risk takers have quit!

8. Of course, the teacher stops the activity at this point as students could get injured if they actually reached into bag #3. The bag contents are now revealed.

9. Follow-up discussion:

a. Ask the risk takers to tell the group what their assistant whispered in their ear.

b. Did all the assistants see the same contents?

c. Discuss how the risk takers thought they could "beat the odds."

d. Discuss comments that encouraged/discouraged each from stopping or continuing with the activity.

e. Finally, discuss what risks each are willing to take; which would not be safe risks; what risks are involved with AIDS/HIV conditions.

Time Frame: This activity takes between 20-40 minutes to complete. The time frame may vary depending on grade level and the number of comments made or points raised during the discussion.

ACTIVITY #3: "A SAFER SEX CONTINUUM"

Objective: At the completion of this activity the student will be able to identify means of transmission of AIDS/HIV on a safer to unsafe continuum.

Preparation: When discussing the issue of AIDS in the classroom, one way to introduce safe and unsafe sexual practices is by using the "Safer Sex Continuum." This activity would be part of a larger unit on sexuality or sexually

transmitted diseases (STDs) and would be utilized once the students had developed a degree of comfort in discussing sexual topics.

Materials Necessary:

chalkboard and chalk
(or newsprint and marking pens)

Activity:

1. Introduce the topic by having students consider the methods of transmission of the HIV virus and sexual practices. Place the continuum shown at the bottom of the page on the chalkboard.

2. At this point, ask the students to "place" a sexual activity on this continuum on the appropriate position so as to indicate the "safeness" or "riskiness" of the behavior. As each behavior or sexual activity is suggested, the elements involved in ranking that behavior in that position should also be discussed. This method involves the students in analyzing each sexual activity based upon their knowledge of the transmission of the HIV virus. It is also a method that could be useful in introducing sensitive topics such as masturbation, condom use, and anal intercourse.

3. Clarification of certain activities is a productive outcome of this activity if students are allowed to engage in open discussion and ask questions. For instance, one popular misconception discovered with this approach was that some students considered a sexual monogamous relationship to mean having sex with "one person at a time."

Time Frame: This activity takes between 30 and 50 minutes to complete depending upon 1) the level of knowledge of the students, 2) the degree of comfort with discussing sexual topics, and 3) the amount of discussion time allowed.

**ACTIVITY #4:
"THE LIVING YEARS"**

Objective: At the completion of this activity, the student will be able to verbalize his/her reactions to AIDS as a death and dying issue.

Preparation: One effective way we found to address AIDS as a death and dying issue was to play a song that many students may have heard on popular hit radio stations. "The Living Years," recorded by Mike and the Mechanics, was played and students were encouraged to follow along with the printed words. Introductory statements may include: "Think about the words and what they say about death and dying," or, "As you listen to the words of this song, think about your thoughts on death, dying, and AIDS."

Materials Necessary:

tape: "The Living Years," by Mike and the Mechanics
printed words to the song
tape player

The Living Years

Every generation
Blames the one before
And all of their frustrations
Come beating in your door.

I know that I'm a prisoner
To all my father held so dear
I know that I'm a hostage
To all his hopes and fears
I just wish I could have told him
In the living years.

Crumpled bits of paper
Filled with imperfect thought

Stilted conversations
I'm afraid that's all we've got.

You say you just don't see it
He says it's perfect sense
You just can't get agreement
In this present tense
We all talk a different language
Talking in defense.

Say it loud, say it clear
You can listen as well as you hear
It's too late when we die
To admit we don't see eye to eye.

So we open up in quarrel
Between the present and the past
We only sacrifice the future
It's the bitterness that lasts.

So don't yield to the fortunes
You sometimes see as fate
It may have a new perspective
On a different day
And if you don't give up,
And don't give in
You may just be OK.

Say it loud, say it clear
You can listen as well as you hear
It's too late when we die
To admit we don't see eye to eye.

I wasn't there that morning
When my father passed away
I didn't get to tell him
All the things I had to say,
I think I caught his spirit
Later that same year
I'm sure I heard his echo
In my baby's new born tears
I just wish I could have told him
In the living years.

"The Living Years," Mike and the Mechanics (1988), Atlantic Record Corporation, 75 Rockefeller Plaza, New York, NY 10019.