

A GAME MODELING OF A CLOSED-LOOP SUPPLY CHAIN IN A
WATER-ENERGY NEXUS: TECHNOLOGY ADVANCEMENT, MARKET
COMPETITION AND CAPACITY LIMIT

by
Nabeel Hamoud

A Dissertation Submitted in
Partial Fulfillment of the
Requirements for the Degree of
Doctor of Philosophy
in Engineering

at
The University of Wisconsin-Milwaukee

December 2019

ABSTRACT

A GAME MODELING OF A CLOSED-LOOP SUPPLY CHAIN IN A WATER-ENERGY NEXUS: TECHNOLOGY ADVANCEMENT, MARKET COMPETITION AND CAPACITY LIMIT

by

Nabeel Hamoud

The University of Wisconsin-Milwaukee, 2019

Under the Supervision of Professor Jaejin Jang

Water and energy are two scarce and concerning resources interconnected in the water-energy nexus. In the nexus, production of energy needs water, and production of water needs energy. For better management of these resources in the nexus, this research considers a supply chain that consists of water suppliers, power suppliers, and consumers of these commodities. In the chain, water suppliers purchase power from power suppliers, and power suppliers purchase water from water suppliers. Other consumers can also buy these resources at the water and power markets. Each firm tries to maximize its own profit. The suppliers of water and power decide their production quantities. The prices of the commodities depend on the quantities supplied to the market, observing that a firm's profit is dependent not only on its own decision, but also on the decision of the other firms for their production quantities. The interaction of the firms in the supply chain is modeled as a simultaneous game.

Four different market structures (i.e., models) are introduced in this research. The first model considers a monopoly power market and a monopoly water market. In this model, we find the Nash equilibrium and analyse various economic measures. We also investigate the effect of technology efficiency on the same market as well as on the cross market. In the second model, we consider a duopoly in the water market, where the two firms are identical. The purpose of this model is to investigate the effect of market competition on the firms of the same industry and the firms of the cross industry. The third model generalizes the second model by considering oligopoly markets with identical firms. Another assumption of the above models, besides their being identical, is that the firms do not have capacity limits. In the last model, we relax these assumptions and consider that power suppliers may own more than one generating unit (i.e., power plant). A case study is considered with different scenarios to investigate the effect of technology efficiency and capacity limits.

In these models, we find the Nash equilibria and derive various economic measures. The analysis shows that there are unique Nash equilibria under some conditions and multiple Nash equilibria under other conditions. When there are multiple equilibria, a government can provide incentives so that the firms can choose a Pareto optimal decision for the benefit of all entities involved. We find that depending on the conditions of the markets, technology improvement does not always lead to better outputs and better economic measures. When there are enough supplies for the firms and consumers to purchase, improvement of production technology for reduced water and power consumption also improves all economic measures of the supply chain, including social welfare. Under the same condition, higher competitions in the water or energy industry also improve all economic measures. However, when either the water or the power supply is solely consumed by the firms in the cross industry, the improvements of technology and higher competition can give negative effects on

some measures. When an industry has a new entrant (competitor), the incumbent firms may earn higher profits if the technology inefficiency remains above 60%. While more efficient firms may have a competitive advantage to produce more, a limited capacity may shift this competitive advantage to less efficient firms if they have higher capacity limits when demand is high.

© Copyright by Nabeel Hamoud, 2019
All Rights Reserved

DEDICATION

To

my wife, Nahlah Mandurah,

my daughter, Layla,

my son, Omar,

my parents,

and

my brothers and sisters

TABLE OF CONTENTS

ABSTRACT	ii
DEDICATION	vi
LIST OF FIGURES	xi
LIST OF TABLES	xiii
ACKNOWLEDGMENT	xiv
1 INTRODUCTION	1
1.1 Background	1
1.2 Water and Energy	3
1.3 Water-Energy Nexus (WEN)	7
2 LITERATURE REVIEW	11
3 PROBLEM DESCRIPTION	17
3.1 Power Markets	17
3.2 Water Markets	18
3.3 Water-Energy Nexus Structures	19
4 MODEL I: ONE POWER SUPPLIER AND ONE WATER SUPPLIER	22
4.1 Introduction	22
4.2 Solution Approach	24
4.3 Equilibrium Analysis	25
4.4 Pareto Optimal Equilibrium	30
4.5 Effect of Technology Improvement	31

5	MODEL II: ONE POWER SUPPLIER AND TWO WATER SUPPLIERS	34
5.1	Introduction	34
5.2	Solution Approach	35
5.3	Equilibrium Analysis	36
5.4	Effect of Cournot Competition in Duopoly Markets	40
6	MODEL III: MULTIPLE POWER SUPPLIERS AND MULTIPLE WATER SUPPLIERS	45
6.1	Introduction	45
6.2	Solution Approach	46
6.3	Equilibrium Analysis	47
6.4	Effect of Cournot Competition in Oligopoly Markets	50
7	MODEL IV: MULTIPLE NON-IDENTICAL POWER SUPPLIERS AND MULTIPLE NON-IDENTICAL WATER SUPPLIERS	57
7.1	Introduction	57
7.2	Solution Approach	60
7.3	Case Study	61
8	CONCLUSION AND FUTURE RESEARCH	71
8.1	Conclusion	71
8.2	Future Research	74
	REFERENCES	74
	APPENDICES	85
A	WATER USAGE OF NON-RENEWABLE POWER PRODUCTION TECHNOLOGIES	86

B	ANALYSIS OF MODEL I	90
B.1	Proof of the equilibrium of case I-1	91
B.2	Proof of the equilibrium of case I-2	93
B.3	Proof of the equilibrium of case I-3	95
B.4	Economic measures of Model I	98
B.5	Proof of Pareto optimality of case I-1 (multiple equilibria)	99
B.6	Effect of technology improvement on the economic measures of Model I	104
C	ANALYSIS OF MODEL II	107
C.1	Proof of the equilibrium of case II-1	108
C.2	Proof of the equilibrium of case II-2	110
C.3	Proof of the equilibrium of case II-3	112
C.4	Economic measures of Model II	113
C.5	Proof of the effect of competition on the producer surplus of the water market (case 1)	115
C.6	Proof of the effect of competition on the producer surplus of the power market (case 1)	116
C.7	Proof of the effect of competition on the consumer surplus of the water market (case 1)	117
C.8	Proof of the effect of competition on the consumer surplus of the power market (case 1)	117
D	ANALYSIS OF MODEL III	118
D.1	Economic measures of Model III	118
D.2	Proof of the effect of competition on the total output of the same industry (case III-1)	119

D.3	Proof of the effect of competition on individual outputs and profits of the firms in the same industry (case III-1)	120
D.4	Proof of the effect of competition on the total output of the cross industry (case III-1)	121
D.5	Proof of the effect of competition on individual outputs and profit of firms in the cross industry (case III-1)	121
D.6	Proof of the effect of competition on consumer surplus (case III-1)	122
D.7	Proof of the effect of competition on individual outputs of the cross industry (case III-2)	122
D.8	Proof of the effect of competition on individual outputs of the same industry (case III-2)	123
	CURRICULUM VITAE	124

LIST OF FIGURES

1.1	Renewable water resources per capita in 2010	2
1.2	Global water demand: baseline (2000) and 2050	3
3.1	ISOs/RTOs in North America	18
3.2	Water trades in California	19
4.1	Water-energy nexus of Model I (PS: Power Supplier, WS: Water Supplier) .	23
4.2	Input conditions of Model I	27
4.3	Conditions of regions A (left) and B (right) of Case I-2	29
4.4	Equilibrium domains of the water-energy nexus with monopoly markets (the numbers are the case numbers of Model I)	31
4.5	The effect of demand curve change for Case I-2.A	32
5.1	Water-energy nexus of Model II	34
5.2	Equilibria domains of the water-energy nexus with Cournot competition . . .	40
6.1	Water-energy nexus of Model III	45
6.2	Effect of competition on the domains	51
6.3	The domain of increased social welfare with more power suppliers in case III-1	54
6.4	Domain space where water suppliers increase individual outputs with higher competition	56
7.1	Water-energy nexus of Model IV	58
7.2	PJM market participants	62

7.3	Economic measures: benchmark vs NIUL	66
7.4	Economic measures: benchmark vs NIUL vs NIL	68
7.5	Supply curve shift	69
7.6	Economic measures: benchmark vs WIL	70

LIST OF TABLES

1.1	Water type and salinity level	6
3.1	Notation	21
7.1	Economic measures of the benchmark scenario	65
7.2	Water efficiency of power plants (ψ)	65
7.3	Outputs of power plants in NIUL scenario	66
7.4	Outputs of power plants in NIL scenario	67
A.1	Water consumption factors for non-renewable technologies (gal/MWh)	86
A.2	Water withdrawal factors for non-renewable technologies (gal/MWh)	88
B.1	Economic measures of case I-1	98
B.2	Economic measures of case I-2	98
B.3	Economic measures of case I-3	99
B.4	Effect of technology improvement on economic measures of case I-1	104
B.5	Effect of technology improvement on economic measures of case I-2A	105
C.1	Economic measures of case II-1	113
C.2	Economic measures of case II-2	114
C.3	Economic measures of case II-3	115
D.1	Economic measures of case III-1	118
D.2	Economic measures of case III-2	119

ACKNOWLEDGMENT

First and foremost, I would like to express my gratitude and thanks to the Almighty God, for giving me strength and patience to reach my goals.

I am appreciative to the Kingdom of Saudi Arabia for the education they provided me and for the generous scholarships they awarded me to pursue my Masters and Doctoral degrees. I am also appreciative to the College of Engineering & Applied Science and Department of Industrial & Manufacturing Engineering at the University of Wisconsin-Milwaukee for their financial support in the last few years.

I would also like to thank my committee members, Matthew Petering, Wilkistar Otieno, Xiaohang Yue and James Peoples, for their invaluable comments and feedback, which helped me improve my research. Special thanks must be given to my academic advisor, Professor Jaejin Jang, for all the support and guidance he has been giving me throughout the years. He not only taught me how to become a good researcher, but also taught me how to be a better presenter and communicator. He has a sense of humor that helped a lot during our long meetings.

I am extremely grateful to my lifelong supporters, my parents, for their continuous support and prayers. They taught me to never give up and to believe that everything turns well at the end by the grace of God. I would also like to thank my brothers, sisters and in-laws for their encouragement and for believing in me. Special thanks to my older brother, Ehab, for always being there for me.

Last but not least, no words can express my feelings towards my little family, especially

my wife, Nahlah. During this journey, Nahlah has been my best friend, my companion, my consultant, my counselor and many other things. She believed I can accomplish anything I want and made me believe it. Without her constant encouragement, I would not be able to complete this research. I will be forever grateful. I am also grateful to my daughter, Layla and son, Omar, for making my life more fun and colorful and for giving me the motivation to succeed and be a good example for them.

CHAPTER 1:

INTRODUCTION

1.1 Background

In the last decades, there has been a growing concern about the availability of natural resources around the world. Two of these natural resources are water and energy. Many nations are under severe stress, especially for water, such as North and South Africa, and South and Central Asia (see Figure 1.1). Heat waves and droughts are also impacting many areas. In California, for example, the governor issued a Drought State of Emergency in January of 2017 as the state faced the driest year in its history. The demand for water is growing and it is projected to increase by 55% in 2050 compared with 2000 [1] (see Figure 1.2). Similarly, the demand for energy is also expected to increase from 500 Exajoules (EJ) to nearly 900 EJ in 2050 [1]. Dependence on traditional energy sources (i.e., fossil fuels) is expected to remain around 80% throughout 2050. The majority of the traditional energy consumption comes from six emerging economies, BRIICS (i.e., Brazil, Russia, India, Indonesia, China and South Africa) [1].

This rapid demand increase poses risk to our environment. According to the Intergovernmental Panel on Climate Change (IPCC) (2014), human activities have clear impacts on climate change due to the emission of greenhouse gases (GHG) [2]. GHGs trap heat in the atmosphere, causing a temperature increase. It is estimated that temperature increase will be on average between 2.0 and 4.5 Celsius degrees [1]. According to the Organisation for Economic Co-operation and Development (OECD) (2012), the GHG emission from energy

and industrial use is projected to double by 2050 compared to 1990. One of the main contributors of the GHGs is carbon dioxide (CO₂), which comes mainly from producing traditional energy sources such as coal, natural gas and oil. In 2015, 195 nations signed an agreement to reduce their GHG emission, hoping to keep the average temperature from increasing more than 1.5 Celsius degrees.

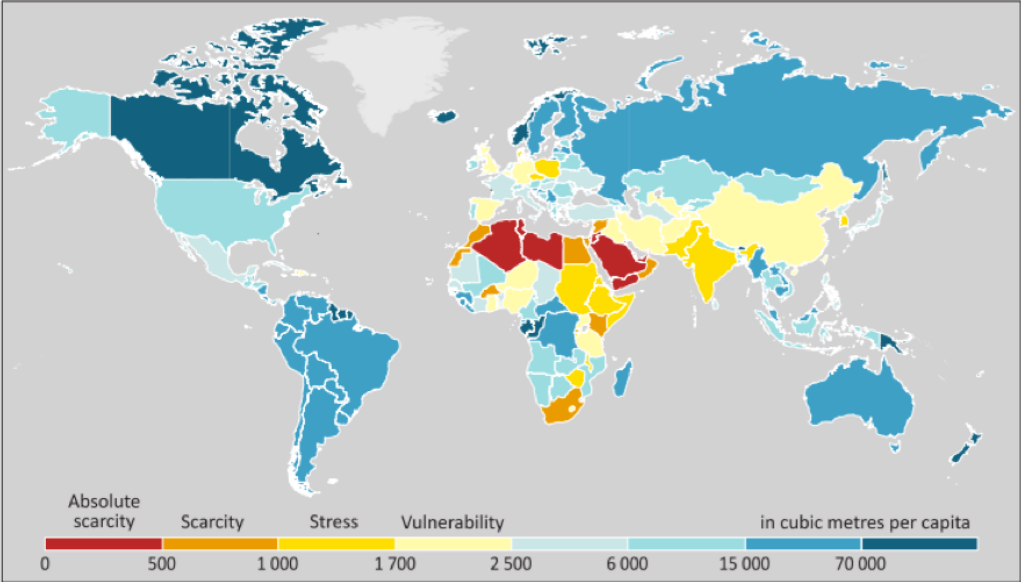

Source: UN FAO Aquastat database.

Figure 1.1: Renewable water resources per capita in 2010

Population growth and a rise in living standards are some factors of the increased demand for water and energy [3]. It is projected that the world population will reach nearly 9 billion in 2050 [1]. With a limited access to renewable sources of water and energy, these two factors will only worsen the situation. It is expected that most of the population will live in urbanized areas, which will increase the stress of water and energy in high density regions. Furthermore, with the rapid advancement of technology, the demand for energy is expected to increase. Population demography also plays a significant role in increasing the demand

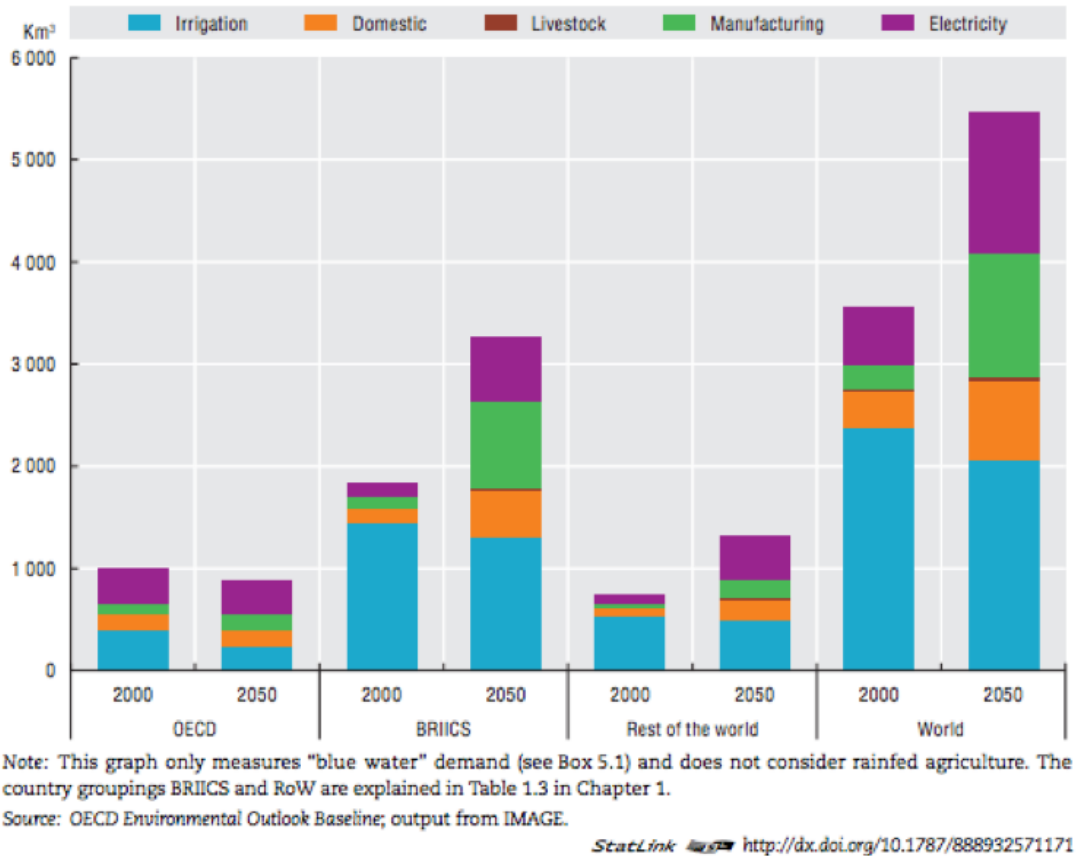

Figure 1.2: Global water demand: baseline (2000) and 2050

for energy and water. As a result of the technological advancement and innovation, it is expected that aging population will rise. In the OECD countries, it is expected that the over 65-year-old population will represent one quarter of the population. In other countries such as Africa, their younger populations will grow rapidly [1]. These demographic changes will certainly impact water and energy security.

1.2 Water and Energy

Water is an important natural resource as the whole economy relies on it [4]. Many industries such as agriculture and energy rely on water. Water consumption varies among

sectors. Agriculture, for example, is a water-intensive industry that accounts for 70% of the water consumed worldwide [5]. Industrial use of water accounts for about 22% globally, but increases among the OECD nations to around 60% [5]. With the increasing concerns of water scarcity, several industries need to reexamine the impact of such a crisis on their operations. One of these industries is power generation, which depends on water for their cooling systems. It is estimated that the amount of freshwater withdrawn by this industry in the U.S. accounts for 41% [6]. It is projected that the global water demand by power plants will increase dramatically (i.e., by 140%) in 2050. Due to the importance of this industry, it will be the focus of this paper.

On the other hand, energy is another important driver for the economy. In fact, energy is a critical element of every industry. The U.S. Department of Homeland Security (DHS) abstracts the importance of energy in one sentence [7]:

"More than 80 percent of the country's energy infrastructure is owned by the private sector, supplying fuels to the transportation industry, electricity to households and businesses, and other sources of energy that are integral to growth and production across the nation," states the DHS.

The primary energy sources are generally divided into two categories, traditional and renewable. Some energy sources are used for fuel production such as crude oil, which undergoes further processing and refining to convert to gasoline. Some others are used directly for power generation by burning the primary energy source. Biomass, depending on the source, can also be converted to transportation fuel by processing feedstocks or can be converted to heat by burning wood waste and municipal solid waste.

Power generation is a water-intensive process after irrigation, with a water withdrawal share of nearly 40% of the total water withdrawn. Most of the water used in power generation comes from thermoelectric and hydroelectric power plants. According to OECD (2012), the water demand for electricity generation will increase by 140% in 2050 [1]. There are two types of power plants, base-load and peak-load. Base-load power plants are intended to provide the minimum power demand at a near constant rate. These power plants have longer lead-time to adjust their power outputs. An example of base-load power plants is nuclear power plants. In contrast, peak load power plants can adjust their outputs with shorter lead times to meet power demand. An example of peak-load power plant is natural gas power plants.

In the thermoelectric power plants, water is used to heat and to cool the steam that drives the generation turbines. There are three main cooling technologies, open-through, wet-recirculating (or closed-loop) and dry cooling. In open-through cooling systems, water is withdrawn in large quantities and used only once. Most of the water withdrawn is discharged to the original water source, but with a higher temperature. In closed-loop cooling systems, water recirculates and is cooled in cooling towers. The majority of the water is lost in the cooling towers due to evaporation. Water is withdrawn to make up the amount of water consumed during the cooling process. Dry cooling does not require water, but cooling the system takes a longer time, which may affect production efficiency. A comprehensive list of water withdrawal and consumption factors for different cooling technologies and different types of fuels is shown in Appendix A [8].

Freshwater is the dominant water source among most industries. Power generation, in particular, is increasingly dependent on freshwater, especially with open-loop cooling technology. Open-loop cooling systems withdraw a substantial amount of water and consume a fraction

of the water withdrawn. Due to the massive amount of water needed for these types of systems, freshwater has become the prevailing water source. When water is abundant, the cost of freshwater to power plants is negligible. However, when freshwater is scarce, power plants tend to find costly alternatives. There are different types of water based on its salinity level. Water salinity level can be determined by measuring the total dissolved solids (TDS) in water. The unit that is commonly used for TDS is part per millions or milligrams per liter (1 ppm = 1 mg/L). The following table shows different water types with their respective salinity level ranges[9].

Table 1.1: Water type and salinity level

WATER TYPE	SALINITY
Freshwater	Less than 1,000 ppm
Slightly saline water	From 1,000 ppm to 3,000 ppm
Moderately saline water	From 3,000 ppm to 10,000 ppm
Highly saline water	From 10,000 ppm to 35,000 ppm
Ocean water	35,000 ppm

Slightly and moderately saline water are sometimes referred to as brackish water. In general, water can be categorized in terms of conventionality. A conventional water source includes freshwater, and unconventional water sources include, but are not limited to, reclaimed or recycled wastewater, saline water and gray water. These water sources require a substantial amount of energy to collect, treat and deliver their effluents to the points of demand.

As shown above, the dependence of water plants and power plants is bidirectional: water plants need energy and power plants need water. Such interdependence is known in the literature as the water-energy nexus. In this research, we focus on the interconnection of water plants and power plants. In the next section, we discuss the water-energy nexus in

more detail to better understand the relationships between the two industries.

1.3 Water-Energy Nexus (WEN)

In this section, we highlight some of the interactions between water and energy from the perspective of the water source, that is, the use of water in the energy sector (i.e., water for energy), and the use of energy in the water industry (i.e., energy for water).

1.3.1 Conventional Water Sources

Freshwater (surface or ground) is the most common source of water used in the energy sector. Surface freshwater has been the dominant source of water in the power industry. Freshwater represents 84% of the water withdrawn by power plants in the United States. Due to the high rate of water withdrawal, it is feasible to locate power plants near the source of water whenever possible. Groundwater use is less than freshwater use, but it is a major source in some areas. For example, the Great Basin withdraws more than 50% of its water demand from groundwater and Hawaii's groundwater water consumption accounts for more than 50% of its total water consumption by power plants [10].

In this type of water, energy is required for pumping the water from the water source to the power plant and for discharging the water back to the source; however, the cost of energy is minimal compared with other operating costs such as fuel costs. Groundwater is used to a lesser extent due to the extra capital and operating cost needed for water extraction, although it is considered the first alternative to surface freshwater.

1.3.2 Unconventional Water Sources

Freshwater is not always available, sometimes due to climate change or site topography, and sometimes due to access restrictions or barriers. For example, water rights in California are based on "first in time, first in right" rule, which means that those who obtained water rights

sooner have a higher priority for using water. There are different alternatives to freshwater, but they usually bear additional costs. According to Harto et al. (2014), 18 percent of all power generators in the US use unconventional water sources [11]. In the following, we discuss these alternatives.

1.3.2.1 Reclaimed or Recycled Wastewater

Reclaimed wastewater is commonly referred to the water received by municipality districts and treated for reuse. When wastewater is not contaminated with feces, it is called grey or gray water. Examples of gray water in residential areas are shower and kitchen discharges. Irrigation and industrial discharges are other great sources of grey water, which are usually chemically contaminated. The level of treatment depends on the purpose of using the treated water, whether industrial, irrigation or human consumption. Some studies show that wastewater can be treated to the quality level of potable water [? ?].

However, the quality of the reclaimed water for non-human consumption is acceptable. Reclaimed water for cooling purposes has been widely used in the last decade, especially in states where heat waves and droughts are impacting water availability. For example, Florida, California and Texas have 17, 13 and 7 reclaimed-water-dependent power plants as of 2007 [12]. Recycled water is used to make up the water lost during the cooling process. Researchers claim that reclaimed water is feasible only for the closed-loop cooling technology [13–15].

The energy use of wastewater treatment is much higher than freshwater treatment. Power is needed for pumping, delivering and treating wastewater as well as for distributing treated water to the points of demand. It must be noted that wastewater treatment plants can also produce byproducts from biosolids such as fertilizers and biomass energy by converting the

methane emitted by biosolids into biofuel [16]. For example, East Bay Municipal Utility District is the leader in this area, producing more than their demand for energy. The excess of energy is sold to the power grid [17]. In Wisconsin, Madison Metropolitan Sewerage District satisfies 30 percent of its energy demand by producing methane [18].

1.3.2.2 Saline Water and Desalinated Water

As mentioned earlier, saline water includes brackish water (i.e., low to moderate salinity) and sea and ocean water (i.e., high salinity). Saline water can be treated and transformed to freshwater by desalination. Desalination is the process of removing the dissolved solids or salts from the liquid. The quality standard of desalinated water depends on the purpose of using the water. For example, the quality standard of potable water is very high with a TDS of less than 50 ppm, while irrigation can tolerate low and to some extent moderate salinity.

There are different techniques of water desalination. The most common techniques used are reverse osmosis (RO) and multistage flash (MSF). RO uses a couple of membranes to pass the saline water through until reaching a satisfactory TDS level, while MSF simulates the natural water cycle by heating the water and condensing the vapor. Desalination is commonly used in locations where access to freshwater is limited and saline water is abundant.

In power generation, there are two ways that saline water can be used for cooling the steam [11]. One way is that saline water can be used without altering its quality. This approach requires special cooling towers (i.e., saline cooling towers), which are more impervious to the higher salinity level. The downside of this cooling tower type is efficiency. Saline cooling towers are less efficient than the freshwater cooling towers. A larger capacity is required to produce the same outputs of smaller freshwater cooling towers. The other approach is

desalinating saline water and using traditional freshwater cooling towers.

Desalination is not the best alternative as it raises environmental concerns and dangers to ecosystems. However, when access to freshwater is extremely limited, desalination becomes a valuable alternative, as in the example of the Middle East and U.S. southwestern states, especially for potable water. Beside the environmental concerns of water desalination, energy demand is another major concern. Desalination is one of the most energy-intensive processes, which makes it the most expensive alternative. RO requires energy in the form of electricity, while MSF requires heat to simulate the water cycle process. Due to technological advancement in membrane efficiency, RO has been gaining more attention lately. MSF, on the other hand, can be found in regions where energy sources and/or heat byproduct are abundant, such as in the Middle East.

CHAPTER 2:

LITERATURE REVIEW

The area of water-energy nexus is very broad. Consequently, in this research, the scope is limited to the interconnection between the water industry and a subset of the energy industry, the power generation industry. Generally, there are two types of literature on the water-energy nexus, qualitative and quantitative. The qualitative literature is not the focus of this review, but it is important to highlight some of it to understand the importance of the water-energy nexus area.

Harto et al. (2014) present some of the opportunities and challenges of using saline water in power plants [11]. While freshwater is the dominant source of water, with 76% of the power generators using freshwater, approximately 7% of the currently operating facilities use saline water as their cooling source. In addition, 6% of the power generators use brackish water and 5% use reclaimed water [11]. A study highlights the lack of power plant water use data and the absence of water use regulations in many U.S. states [19]. Another study reviews the impact of water availability and cooling system options on the UK's future water demand and environmental policies [20]. Stillwell (2015) assesses the sustainability of the recent water-energy nexus policies introduced by the U.S. Congress [21].

Scenario analysis of the water-energy nexus is one of the areas receiving much attention in the research community. In this area, data for the current state are gathered and projections are made based on certain assumptions and conditions. Ackerman and Fisher (2013) developed four scenarios of a long run electricity generation planning for the West Coast of the U.S.

through year 2100 [22]. The model is tested for a range of water and carbon prices. The authors conclude that it is feasible to reshape the power generation sector in the West Coast by carbon pricing, but not with water pricing because it is believed that water prices should be higher to show noticeable effects.

Liu et al. (2015) used GCAM-USA to estimate water withdrawals and consumption of the U.S. power industry at the state level [23]. They modeled seven scenarios considering factors such as fuel types and cooling technology mix. They show that shifting from open-loop cooling to closed-loop cooling is favorable. They also find that strategies such as using carbon capture storage (CCS) and nuclear are less favorable due to their intensive water consumption rates. Another study investigates energy consumption of the water supply systems in Brazil [24]. They examined the efficiency of the water supply systems in the five geopolitical regions of Brazil and found that 30% of the energy is lost due to water loss and that some regions would benefit more than others from energy and water efficiency strategies.

Schoonbaert (2012) examines the impact of the UK's energy and water policies on future water security. The scenarios developed are based on the number of approved and planned thermoelectric power generation facilities. One of the author's recommendations is to establish a water pricing mechanism to promote water conservation [25]. The Great Lakes Commission (2011) investigates five different scenarios of the water use for thermoelectric power generation in the Great Lakes Basin region. Water withdrawal is expected to increase by 10% in the business-as-usual scenario, but it would decrease by 87% if open-loop cooling systems were prohibited [26]. DeNooyer et al. (2016) study the impact of shifting fuels and retrofitting cooling systems in power plants in Illinois. They find that shifting from coal to natural gas reduces water withdrawal and consumption by 37% and 32%, respectively. They

also find that shifting to closed-loop systems reduces water withdrawals by 96% at the cost of increasing water consumption by nearly 58% [27].

Life cycle analysis (LCA) has been used widely for analyzing the water-energy nexus. LCA is a quantitative tool that assesses and analyses the life of a product or facility from creation to disposal and is widely used in the decision making area [28]. Li et al. (2012) investigate the supply chain of the wind power generation in China, focusing on water consumption and carbon emissions [29]. As China has become the largest wind power supplier, the amount of CO₂ emitted and water consumed upstream (i.e., during manufacturing) cannot be overlooked. The study shows that although the water consumed and the carbon produced during the life cycle of the wind turbines is significant, they are much less than the amount of water used by conventional power generating technologies. Another study combines an LCA and an input-output analysis (IOA) to investigate the water consumption and carbon emissions of eight power generation technologies in China. They show that shifting power generation sources from carbon intensive energy sources (e.g., coal) to low-carbon energy sources (e.g., wind) reduces water consumption significantly [30]. Yang and Chen (2016) develop an LCA model to analyze the energy consumed for water extraction and treatment. They also develop a network-enviro-analysis (NEA) model to identify the elements of the network and highlight the relationships between water and energy [31].

Wong and Johnston (2013) investigate the possibility of replicating the cooling system design of the Turkey Point power plant in five other power plants, taking into consideration factors such as the type of soil and water availability [32]. The cooling system of the Turkey Point power plant is unique, with an area of 6000 acres with multiple canals in a closed system. This system is proven to make the power plant self-sufficient, where water loss is much less

than the other systems as a result of being less susceptible to evaporation. The results show that such replication is feasible, especially in areas where using the traditional cooling systems is not feasible. The integration of wind power and brackish groundwater for the operation of a desalination plant in the state of Texas is also investigated [33]. The authors estimate the energy requirement of the desalination plant and then perform an economic and a geographic analysis to investigate the feasibility of the integration. They find that in some municipalities it is profitable to integrate wind power and brackish ground water desalination. Barker and Stillwell (2016) also perform an economic analysis of an engineered water reuse by power plants and compare it with the de facto water reuse [34]. They find that the engineered water reuse improves reliability and performance at the cost of infrastructure capital cost. Sovacool and Sovacool (2009) study the trade-off between water and electricity using the estimated data of population, water demand and planned available power plant capacity [35].

Gabriel et al. (2016) optimize the use of excess heat produced by industrial processes. Some of the heat recovered from industrial processes is converted to energy for water desalination, water cooling, and power generation [36]. Martin and Grossmann (2015) develop a sequential optimization problem, where they first optimize the system's design that includes biofuel production and other renewable energy sources such as concentrated solar power and wind power and then minimize the total cost of the water network. They find that FT-fuels are more efficient than the other energy sources [37]. Another study investigates the use of renewable energy sources for the desalination of brackish ground water in Texas [38]. In the first step, the power needed for the water treatment is estimated. Second, the size of the energy source or a combination of energy sources is estimated. Finally, an optimization model is developed to find the optimal operational schedule that maximizes profit. Stillwell

and Webber (2014) study the feasibility of using reclaimed water for cooling purposes in thermoelectric power plants in Texas [13]. They show that 62 of the power plants are matched with single wastewater treatment plants for a reclaimed water supply, 30 power plants have multiple optima within 25 miles, and 33 power plants have no feasible solutions. Santhosh et al. (2014) develop a nonlinear programming problem to optimize the economic dispatch of water and power [39]. The model considers a power plant, a water plant and a co-production plant. The model also considers water and power storage. They show that storage facilities reduce the total cost and improve reliability. Zhang and Vesselinov (2016) address a water-energy nexus planning problem, where they solve a bi-level linear programming problem using a fuzzy approach considering the type of water, the type of fuel, GHG emission, and expansion of power plants [40].

Game theory is the study of the behaviors of individuals or firms when their payoffs depend not only on their own actions, but also on the actions of their rivals [41]. The central feature of this study area is the prediction of a game's outcomes based on the beliefs of players toward each other. In the area of the water-energy nexus, there is not much attention paid to analyzing the interactions between the entities of the nexus as a game model. In a study focused on a shale gas production supply chain, the authors model a leader-follower game, where two power plants act as leaders and a shale gas producer acts as a follower. The power plants decide their gas demand and the shale gas producer decides the amount of gas to extract from various wells to maximize its own profit and minimize water consumption [42]. Another study investigates a water and power sharing problem between two countries, Ghana and Burkina Faso. The upstream country (leader) make a decision of the amount of water to consume, and the downstream country (follower) observes and make a decision of the amount of power to share with the leader. The conflict is solved if the two countries

cooperate and self-enforce their agreements [43]. Madani studies the cause of delay of relicensing hydropower plants. Part of the relicensing process is reaching an agreement between hydropower plant operators and other interest groups including environmentalists [44]. The author studies this stage by formulating a bargaining game between the hydropower operators and interest groups. The hydropower operator wants to maximize his profit and the interest groups want to maximize their utilities. Other studies investigated the interaction between water, power and carbon markets considering power plants as the players of the game [45, 46]. Water is modeled as a cost factor in the objective function of the power plants, as tax. The authors proposed a reinforcement learning approach to find the equilibrium. None of the studies discussed above and to the best of our knowledge, no one modeled the water suppliers as decision makers in a water-energy nexus game, In this research, we model the interaction between water plants and power plants, where they both decide the quantity to produce. The firms sell their output to their respected markets, and buy the inputs from the cross-market.

Contribution summary

- Consideration of both water and power markets in a closed-loop water-energy nexus.
- Modeling the firms in the water market as decision makers.
- Modeling the closed-loop supply chain as a game between the firms.
- Studying the effect of technology advancement, market competition and capacity limit on society.

CHAPTER 3:

PROBLEM DESCRIPTION

Different types of power plants have different water use intensity. Thermal power plants (e.g., fossil fuel, geothermal and nuclear power plants) are examples of the water-intensive power plants. Renewable energy sources such as wind and solar use water only minimally, mostly for cleaning purposes. Power plants can use other than freshwater for their cooling systems. Harto et al. (2014) present some of the opportunities and challenges of using saline water for power plant cooling [11]. Different cooling technologies have different water consumption and withdrawal rates (see appendix A) [6]. On the other hand, there are also different types of water plants such as desalination plants, wastewater treatment plants and freshwater suppliers. Their power consumption varies depending on the treatment level, distance and elevation of the water source. The majority of the power consumed by water plants is for water treatment, pumping and delivery.

3.1 Power Markets

In many regions, power suppliers and power consumers participate in a regional market coordinated by an Independent System Operator (ISO) or a Regional Transmission Organization (RTO). A power supplier may own one or more power generation units. Currently, there are ten ISOs/RTOs in North America [47]. These ISOs/RTOs receive offers (bids) from the power suppliers (consumers) for their power supply (demand). The operators dispatch power plants after matching supply and demand and determine the market clearing price. They also ensure reliability of the transmission system. In this study, we consider an ISO/RTO as

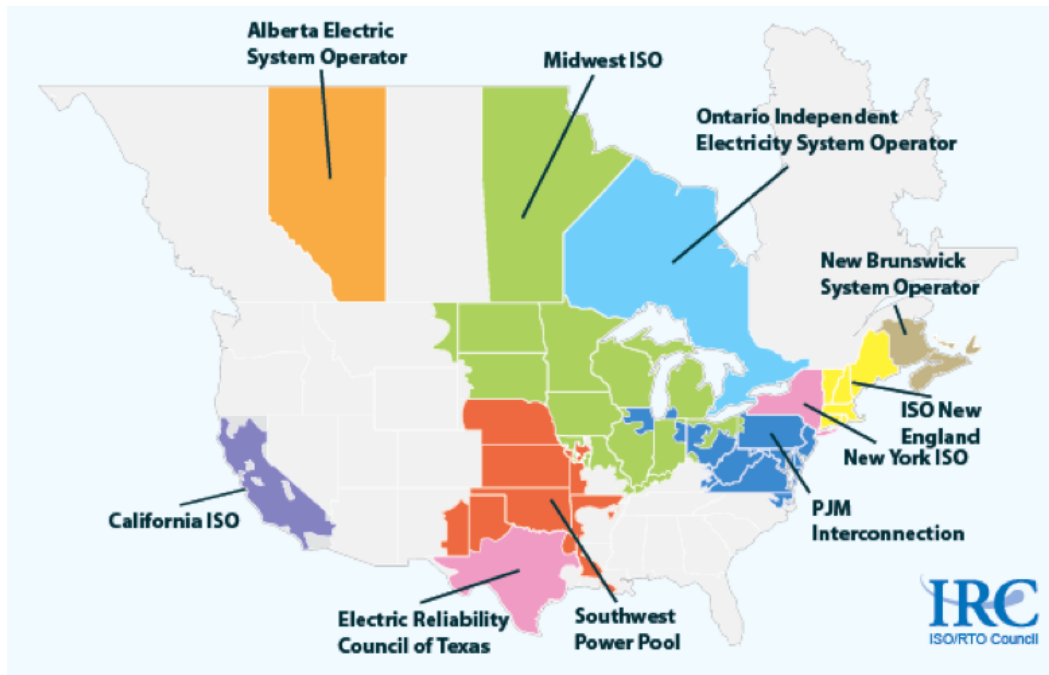

Figure 3.1: ISOs/RTOs in North America

a power market with the exception of the auction process.

3.2 Water Markets

While water is the most demanded commodity, it is believed it is under-valued [22, 48]. Water marketing is a promising tool to drive water to where it is needed the most [49]. Currently, there are a few water markets. Their structures are different from those of the power markets. In the U.S., water has been traded in the form of water rights. There are two types of water rights: prior-appropriation rights (popular in the West Coast) and riparian rights (popular in the East Coast). A water right gives its holder the right to withdraw a specified amount of water from a specific stream . The water right holders can also trade some/all of their rights to other users. In California, water rights can be leased for short term, long term or sold permanently (see Figure 3.2). Australia has a more sophisticated

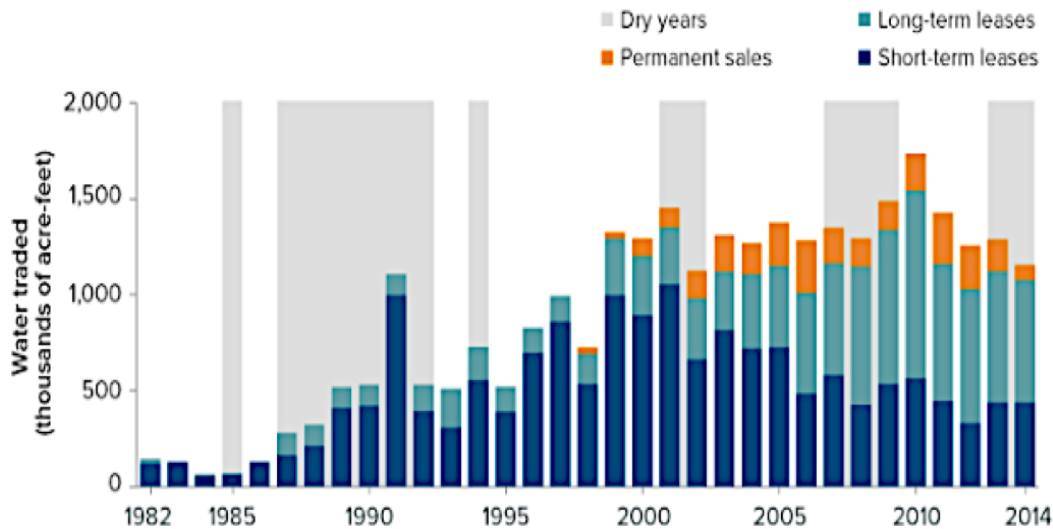

Figure 3.2: Water trades in California

water market that follows a cap-and-trade mechanism. The government allocates quotas to water users, and they trade water online at the market price [50]. In this research, the water market is assumed to be centralized and driven by supply and demand. The price of water is for the delivered product, meaning that it includes any additional cost that may be incurred, such as transportation and pumping costs.

3.3 Water-Energy Nexus Structures

In this study, we consider a supply chain of power and water along with their interrelationship (water-energy nexus); power suppliers purchase water from the water market and sell power at the power market, and water suppliers buy power from the power market and sell water at the water market. At both markets, the prices are determined by the quantity produced. All firms want to maximize their own profits by deciding their respective production quantity. The power suppliers and water suppliers make their decisions independently and simultaneously. The dilemma these firms face is how much to produce to maximize their own profits because the profit of each firm depends not only on its own decision, but

also on other firms' decisions via the prices of the water and energy at the markets. We model the interaction between the power suppliers and water suppliers as a simultaneous non-cooperative game with complete information.

In this research, we consider three different market structures (models) of the supply chain and analytically find the Nash equilibrium. In the first model, we have one power supplier and one water supplier, each serving its own market as a monopolist. In the model, we discuss the possible decisions that the firms may make and how their decisions affect the profits of the firms, the consumer surplus and social welfare. We also study the effect of technology improvement on the aforementioned economic measures. In the second model, we study the effect of Cournot competition in the supply chain; we consider a duopoly in the water market and a monopoly in the power market. In the third model, we generalize the model with oligopoly markets of power and water and investigate the impact of increased competition. The above models consider identical firms when there is competition and assume no capacity limits. In the last model, we relax these assumptions and apply the model on the PJM power market.

To have our analysis be more focused on the main objectives of the research, we consider only direct costs, which are consolidated in the cost of acquiring the cross-industry commodity. For example, the only cost the water supplier bears is the cost of the electricity needed to treat and deliver the water. Although a power supplier or water supplier may own multiple plants, we focus only on the collective output from each firm.

The convention of the notation given in Table 3.1 is that the parameters of the power price and water price are annotated with upper-case letters and lower-case letters, respectively. To distinguish the decision variables of the three models, we assign superscripts. The first

value represents the model number followed by a case number (e.g., $q^{1,1}$). At the markets, the prices of power and water have a linear relationship with the amounts of the commodities supplied to the markets.

Table 3.1: Notation

Parameters	
A	Reservation price of electricity $\$/MWh$
B	Unit price of electricity $\$/MWh^2$
a	Reservation price of water $\$/10^3 \text{ gallons}$
b	Unit price of water $\$/10^3 \text{ gallons}^2$
ϵ	Average power generation factor of water suppliers $MWh/10^3 \text{ gallons}$
ψ	Average water use factor of power suppliers $10^3 \text{ gallons}/MWh$
Decision variables	
q	Quantity of power produced and sold in the market
w	Quantity of water produced and sold in the market

CHAPTER 4:

MODEL I: ONE POWER SUPPLIER AND ONE WATER SUPPLIER

4.1 Introduction

In this model, we consider a single power supplier in the power industry and a single water supplier in the water industry (Figure 4.1). A classic example is a regulated market. Although many countries and states moved toward deregulation, especially for the power industry, market regulations are still dominant in many countries and some states. For example, the power market and water market in Saudi Arabia are dominated by the Saudi Electric Company (SEC) and the National Water Company (NWC), respectively. In Nevada, NVEnergy has been a monopolist power supplier until recently.

The water supplier (WS) and the power supplier (PS) produce and sell their outputs to their respected markets, and they also buy their input resources from the markets for production. The markets are also accessed by other power and water users, retailers, or just consumers hereafter. The parameter, ψ , refers to the water use factor of power plants, which can be associated with water consumption or water withdrawal, even in which case water cannot be reused without the treatment by the water supplier. The price of electricity is determined by the inverse linear demand function depending on the amount of electricity provided to the market, $P^p = A - Bq$. The price of water is determined similarly, $P^w = a - bw$. The demand of these commodities reflects the demand of consumers as well as the not-yet determined

additional demand of the cross-industry firm. The power supplier and the water supplier can buy water and electricity only up to the quantities available in the markets. Both suppliers want to maximize their own profits by choosing their output quantities, q and w .

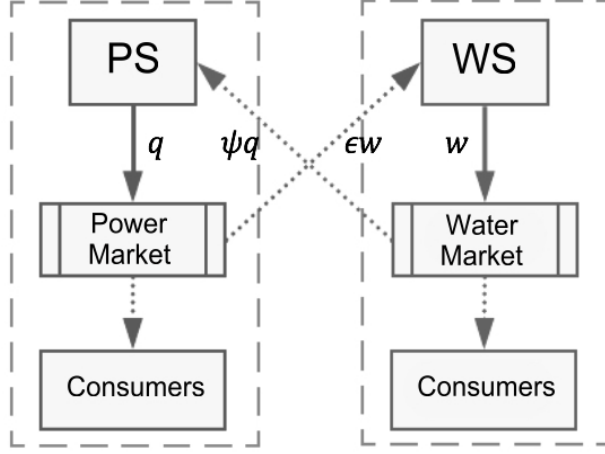

Figure 4.1: Water-energy nexus of Model I (PS: Power Supplier, WS: Water Supplier)

The problem of the power supplier is as follows:

$$\begin{aligned}
 \max_q \quad & (A - Bq)q - (a - bw)\psi q \\
 \text{s.t.} \quad & \psi q \leq w \quad (\lambda_1) \\
 & q \geq 0
 \end{aligned} \tag{4.1}$$

The problem of the water supplier is as follows:

$$\begin{aligned}
 \max_w \quad & (a - bw)w - (A - Bq)\epsilon w \\
 \text{s.t.} \quad & \epsilon w \leq q \quad (\lambda_2) \\
 & w \geq 0
 \end{aligned} \tag{4.2}$$

Here, ψq is the amount of water needed by the power supplier to produce q units of electricity, and ϵw is the amount of electricity needed by the water supplier to produce w units of water. Because the objective functions are concave and the constraints are linear, any local maximizers are global maximizers of the problem. We can determine the equilibrium quantities of electricity and water that the suppliers would produce by solving these two problems simultaneously.

4.2 Solution Approach

The Nash equilibria of this supply chain can be found by using the Karush-Kuhn-Tucker (KKT) conditions [51].

Lagrangian functions of problems (4.1) and (4.2) are:

$$L_1(q, \lambda_1) = (A - Bq)q - (a - bw)\psi q - \lambda_1(\psi q - w)$$

$$L_2(w, \lambda_2) = (a - bw)w - (A - Bq)\epsilon w - \lambda_2(\epsilon w - q)$$

and the KKT conditions are:

$$0 \leq q \quad \perp \quad A - 2Bq - (a - bw)\psi - \psi\lambda_1 \leq 0$$

$$0 \leq w \quad \perp \quad a - 2bw - (A - Bq)\epsilon - \epsilon\lambda_2 \leq 0$$

$$0 \leq \lambda_1 \quad \perp \quad \psi q - w \leq 0$$

$$0 \leq \lambda_2 \quad \perp \quad \epsilon w - q \leq 0$$

The variables, λ_1 and λ_2 , are the shadow prices of the constraints in (4.1) and (4.2), respectively. The conditions are reproduced at the beginning of Appendix B in a different form for later derivations.

4.3 Equilibrium Analysis

Since the problems have two decision variables and two dual variables, there could be a combination of 16 possible cases to consider for non-negativity of the variables. Since the two suppliers depend on each other for their inputs, it is not possible for one firm to produce any quantity when the other firm does not. Also, we consider the cases that produce positive outputs only. This reduces the non-trivial cases to four cases. In the first case, the dual variables are set equal to zero ($\lambda_1 = 0$ and $\lambda_2 = 0$). In the second and third cases, one of the dual variables is set to zero and the other is positive. In the fourth case, both dual variables are set to positive; in this case, one of the firms produces a negative profit as discussed in the next paragraph.

The technology efficiencies play a significant role in this supply chain. We call the product of the terms ψ and ϵ the overall inefficiency factor. The higher the value of $\psi\epsilon$, the less efficient the supply chain is. When $\psi\epsilon = 1$, the total output of one firm is equal to the input of the other firm. Thus, no consumer of either market buys either water or power. The game between the firms when $\psi\epsilon = 1$ becomes a zero-sum game, where the gain of one firm is equal to the loss of the other firm ($\pi_P = -\pi_W$). If $\psi\epsilon > 1$, the system is not sustainable; that is, a certain quantity of output of one firm is not sufficient to feed the other firm to produce enough quantity to support back the original output amount of the first firm.

The remainder of this paper considers only the cases with $\psi\epsilon < 1$, the efficient cases. This leaves us with three cases in which the outputs are positive and the firms generate profits. In case I-1, either firm produces strictly more output than the demand of the other firm, and the consumers buy both commodities. We call this case the normal case.

Proposition 1. (Equilibrium of case I-1, normal case)

When there are one power supplier and one water supplier, and demand of water and power is less than their supply, if

$$\psi\epsilon < 1 \text{ and } \frac{\epsilon((2 - \epsilon\psi)\epsilon B + \psi b)}{((2 - \epsilon\psi)b + \epsilon^2 B)} \leq \frac{A\epsilon}{a} \leq \frac{\epsilon((2 - \epsilon\psi)B + \psi^2 b)}{((2 - \epsilon\psi)\psi b + \epsilon B)},$$

the following is a positive NE:

$$q^{1,1} = \frac{(2 - \epsilon\psi)A - a\psi}{(4 - \epsilon\psi)B} > 0$$

$$w^{1,1} = \frac{(2 - \epsilon\psi)a - A\epsilon}{(4 - \epsilon\psi)b} > 0$$

and the dual variables,

$$\lambda_1^{1,1} = \lambda_2^{1,1} = 0$$

The consumers of both markets buy positive amount of water and electricity from the markets.

The proof is given in Appendix B.1.

The range of input parameters, or input conditions, for case I-1 is shown in Figure 4.2(a). In this case, all economic measures such as profits of firms, consumer and producer surpluses (i.e., the sum of profits as capital costs are ignored), and social welfare can be obtained from these values and be shown to be strictly positive. Appendix B.4 summarizes the equilibrium values of case I-1.

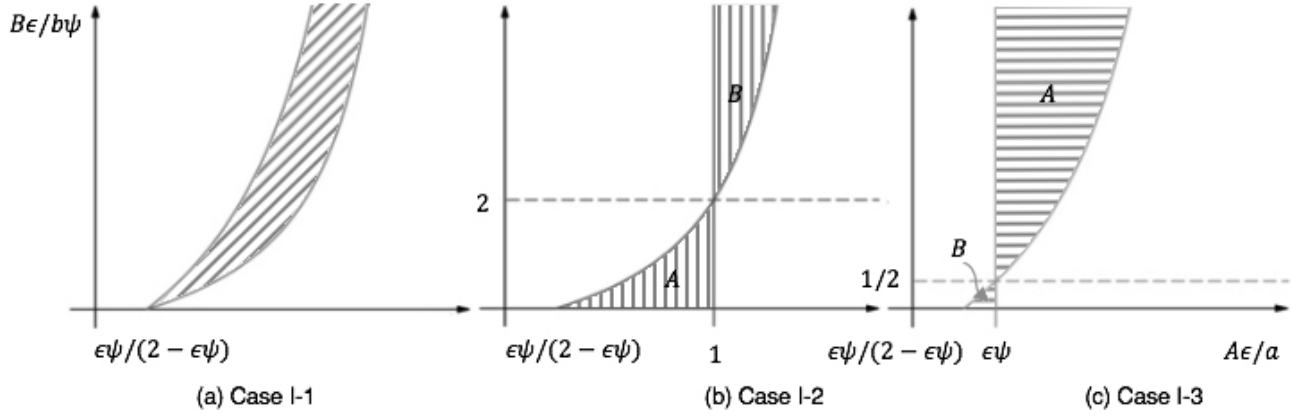

Figure 4.2: Input conditions of Model I

Proposition 2. (*Equilibrium of case I-2*)

When there are one power supplier and one water supplier, and water demand equals water supply, if

$$\psi\epsilon < 1, \frac{B\epsilon}{b\psi} < 2 \text{ and } \frac{\epsilon((2-\epsilon\psi)B + \psi^2b)}{((2-\epsilon\psi)\psi b + \epsilon B)} < \frac{A\epsilon}{a} < 1 \text{ (case I - 2.A), or}$$

$$\psi\epsilon < 1, \frac{B\epsilon}{b\psi} > 2 \text{ and } 1 < \frac{A\epsilon}{a} < \frac{\epsilon((2-\epsilon\psi)B + \psi^2b)}{((2-\epsilon\psi)\psi b + \epsilon B)} \text{ (case I - 2.B),}$$

the following is a positive NE:

$$q^{1,2} = \frac{A\epsilon - a}{B\epsilon - 2b\psi} > 0$$

$$w^{1,2} = \frac{\psi(A\epsilon - a)}{B\epsilon - 2b\psi} = \psi q^{1,2} > 0$$

and the dual variables,

$$\lambda_1^{1,2} = \frac{2Ba - AB\epsilon - 2Ab\psi + ab\psi^2 + Abe\psi^2 - Bae\psi}{\psi(B\epsilon - 2b\psi)} > 0$$

$$\lambda_2^{1,2} = 0$$

The water output is bought entirely by the power supplier, and the water consumer does not buy any water. The proof is given in Appendix B.2.

The input condition of case I-2 is shown in Figure 4.2(b). In the figure, the horizontal dashed line divides case I-2 into two regions: A and B. From the derivative of the profit function of the water supplier to get the marginal revenue and the marginal cost and using the binding condition ($w = \psi q$), we find a lower reservation cost of water than the reservation price of water in region A. In other words, the marginal revenue curve cuts the decreasing marginal cost curve from above in region A as shown in Figure 4.3 ¹. The opposite is true for region B. In either of these two regions, the power supplier buys all water from the water supplier. All the economic measures are shown in Appendix B.4. Beside the profit of the power supplier, it can be easily inspected that the water supplier's profit, the consumer surpluses of the power and the water markets are all positive. The positivity of the profit of the power supplier can be shown by solving the numerator for $A\epsilon/a$ after setting it at zero: we find that $A\epsilon/a$ is greater than $\frac{\epsilon((2-\epsilon\psi)B+\psi^2b)}{((2-\epsilon\psi)\psi b+\epsilon B)}$ (i.e. an input condition of case I-2).

¹This case is similar to natural monopoly, which also has a decreasing marginal cost.

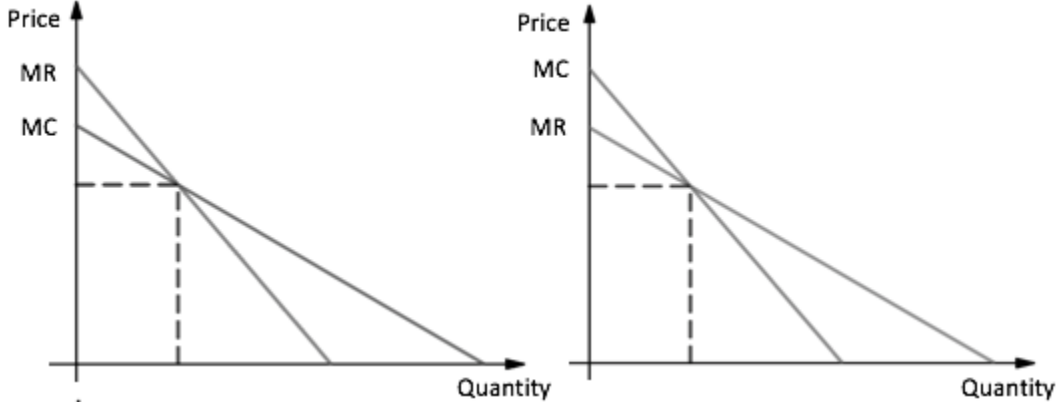

Figure 4.3: Conditions of regions A (left) and B (right) of Case I-2

Proposition 3. (Equilibrium of case I-3)

When there are one power supplier and one water supplier, and power demand equals power supply, if

$$\psi\epsilon < 1, \frac{B\epsilon}{b\psi} < \frac{1}{2} \text{ and } \epsilon\psi < \frac{A\epsilon}{a} < \frac{\epsilon((2-\epsilon\psi)\epsilon B + \psi b)}{((2-\epsilon\psi)b + \epsilon^2 B)} \quad (\text{case I - 3.A}), \text{ or}$$

$$\psi\epsilon < 1, \frac{B\epsilon}{b\psi} > \frac{1}{2} \text{ and } \frac{\epsilon((2-\epsilon\psi)\epsilon B + \psi b)}{((2-\epsilon\psi)b + \epsilon^2 B)} < \frac{A\epsilon}{a} < \epsilon\psi \quad (\text{case I - 3.B}),$$

the following is a positive NE:

$$q^{1,3} = \frac{\epsilon(A - a\psi)}{2B\epsilon - b\psi} = \epsilon w^{1,3} > 0$$

$$w^{1,3} = \frac{A - a\psi}{2B\epsilon - b\psi} > 0$$

and the dual variables,

$$\lambda_1^{1,3} = 0$$

$$\lambda_2^{1,3} = -\frac{2Ab - 2Ba\epsilon - ab\psi + AB\epsilon^2 + Ba\epsilon^2\psi - Abe\psi}{\epsilon(2B\epsilon - b\psi)} > 0$$

The power output is bought entirely by the water supplier, and the power consumer does not buy any power. The proof is given in Appendix B.3.

Since case I-3 is symmetric to case I-2, the discussion of case I-2 applies to case I-3. The input conditions of the parameters are shown in Figure 4.2(c).

4.4 Pareto Optimal Equilibrium

The analysis shows that there can be a unique equilibrium or multiple equilibria, depending on the input conditions (Figure 4.4). We observe a unique equilibrium when the marginal revenue curve cuts the marginal cost from above ($\psi\epsilon < A\epsilon/a < 1$). On the other hand, as can be seen in the figure, there are four regions of multiple equilibria. In the two regions marked with 2A,3B and 3A,2B, one of the firms buys all the output of the cross-industry firm and sells its output to its market. In the two other regions (1,2B and 1,3B), either both firms sell to their customers or one of the firms sells solely to the cross-industry firm. If a Pareto optimal equilibrium exists in these cases, the choice of firms will be more predictable. In the former cases (2A,3B and 3A,2B), the customers would receive one commodity only, either water or power. In the latter cases (1,2B and 1,3B), however, the customers would receive both commodities, which we discuss and prove in the following because there is a significant difference between the outcomes of the two equilibria in these cases.

Under an input condition with multiple equilibria, if one of them is from case 1 (normal case), it can be shown that it is Pareto optimal. That is, the firms' profits, the consumer surpluses of the two markets and social welfare are higher in the normal case than in the other cases. The proof is given in Appendix B.5. For more discussions on general multi-equilibria

and Pareto optimality, refer to Church and Ware (2000) and LaValle (2006) [52, 53]. Some degree of coordination helps the firms to achieve the Pareto optimal equilibrium, possibly via a public agency or an independent market coordinator. Especially since the two suppliers exist in different markets, vertical coordination is plausible without violating the anti-trust laws.

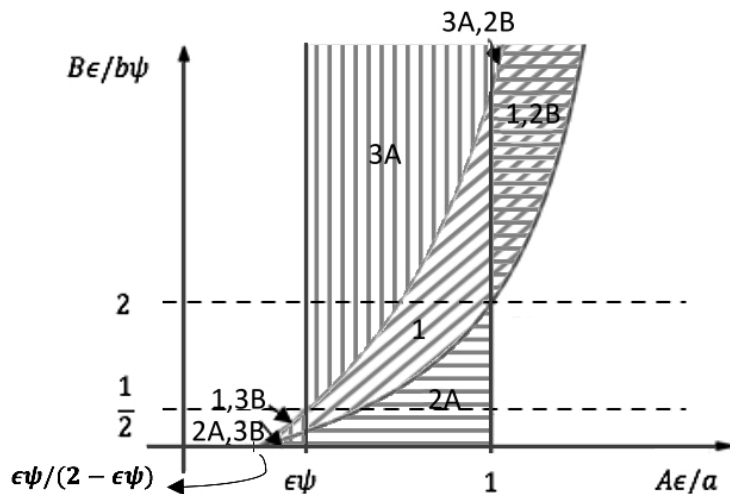

Figure 4.4: Equilibrium domains of the water-energy nexus with monopoly markets (the numbers are the case numbers of Model I)

4.5 Effect of Technology Improvement

People try hard to reduce water use for power generation and reduce power consumption for water production. In this section, we study how the technology improvement affects the supply chain equilibria.

In case I-1 (normal case), in which the consumers buy both water and power, the improvement of technology efficiency of a firm increases not only the output of its own industry ($-\partial q^{1,1}/\partial\psi > 0$), but also that of the other industry ($-\partial w^{1,1}/\partial\psi > 0$). For example, improving the efficiency of the cooling system of the power supplier entices it to

produce more power. The power increase reduces the market price that the water supplier pays, which in turn increases the water output. The profits of these firms, the consumer surplus and the social welfare all increase with the technology efficiency improvement: $-\partial\pi_P^{1,1}/\partial\psi, -\partial\pi_W^{1,1}/\partial\psi, -\partial CS_W^{1,1}/\partial\psi, -\partial CS_P^{1,1}/\partial\psi, -\partial SW^{1,1}/\partial\psi > 0$ (Appendix B.6 shows the values). Since the problem of the water supplier is symmetric to that of the power supplier in case I-1, the same discussion holds for the power supplier in the case.

The impact of improved technology efficiency in cases I-2 (the power supplier buys all water from the water supplier) is not as straightforward as it is in case I-1. In case I-2.A, where we have a lower reservation cost of water than the reservation price, the efficiency improvement of the power supplier (smaller ψ) or the water supplier (smaller ϵ) increases both the water and power productions as well as the profit of the consumed water supplier. If a firm (or a cross-industry firm) becomes more efficient, the marginal cost curve would shift (or rotate) downward (see Figure 4.5). In return, the intersection occurs at a higher quantity. On the other hand, if the marginal revenue curve cuts the marginal cost curve from below, lowering the marginal cost would lead to an equilibrium at a lower quantity as in region B.

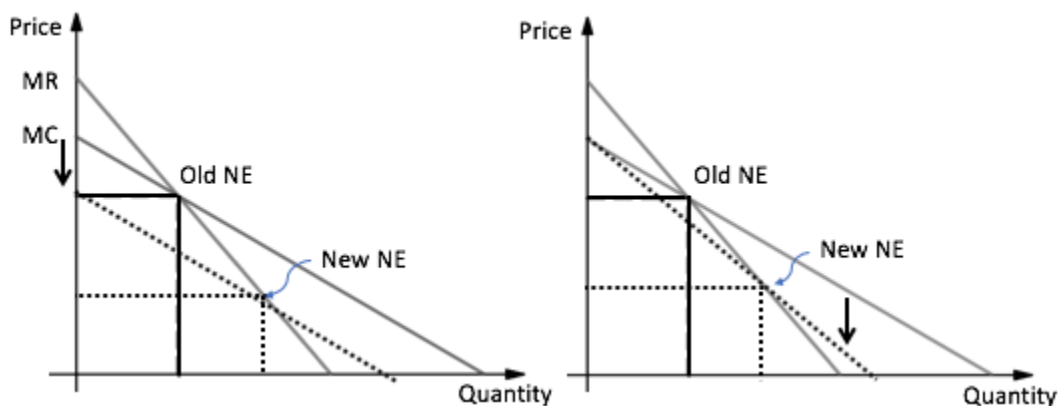

Figure 4.5: The effect of demand curve change for Case I-2.A

The effect of improving technology efficiency on the unconsumed power supplier's profit and social welfare depends on the input conditions:

$$\begin{aligned}
-\frac{\partial \pi_P^{1,2}}{\partial \psi} > 0 &\text{ iff } \frac{A\epsilon}{a} > \frac{B\epsilon(4b - B\epsilon^2)}{2b(B\epsilon(1 - \epsilon\psi) + 2b\psi)} \\
-\frac{\partial \pi_P^{1,2}}{\partial \epsilon} > 0 &\text{ iff } \frac{A\epsilon}{a} > \frac{B\epsilon(2 - \epsilon\psi)}{B\epsilon + 2b\psi(1 - \epsilon\psi)} \\
-\frac{\partial SW^{1,2}}{\partial \psi} > 0 &\text{ iff } \frac{A\epsilon}{a} < -\frac{B\epsilon(B\epsilon^2 + 3b\psi\epsilon - 2b)}{b\psi(-5B\epsilon^2 + 4b)}
\end{aligned}$$

Appendix B.6 shows also the effect of technology improvement on the economic measures of case I-2.A. The effect on the economic measures of case I-2.B is the opposite of those of case I-2.A. The results for case I-3 are symmetric to those of case I-2.

In summary, in the normal case (case I-1), the technology improvement helps all economic measures. However, when one supplier uses all output of the other supplier (cases I-2 and I-3), technology improvement improves the production of both commodities and the profit of the consumed supplier, but it does not always improve the profit of the unconsumed supplier. Similarly, the technology improvement of the unconsumed industry may increase or decrease the social welfare.

CHAPTER 5:

MODEL II: ONE POWER SUPPLIER AND TWO WATER SUPPLIERS

5.1 Introduction

In this chapter, we extend the first model to account for competition in one industry. The purpose is to study the effect of competition of firms on the equilibrium. In this model, we assume the water market is a duopoly with two identical WS's (Figure 5.1). The water suppliers compete for quantity and aim to maximize their own profits. The power market is still a monopoly with a major power supplier.

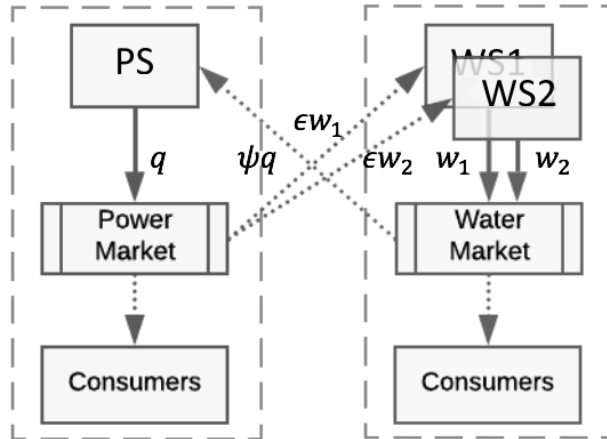

Figure 5.1: Water-energy nexus of Model II

The problems of the power supplier and the water suppliers are similar to that of Model I, except that w becomes $(w_1 + w_2)$. The profit-maximizing problem of the power supplier is:

$$\begin{aligned}
\max_q \quad & (A - Bq)q - (a - b(w_1 + w_2))\psi q \\
\text{s.t.} \quad & \psi q \leq w_1 + w_2 \quad (\lambda_1) \\
& q \geq 0
\end{aligned} \tag{5.1}$$

And the profit-maximizing problem of the water suppliers are:

$$\max_{w_1} \quad (a - b(w_1 + w_2))w_1 - (A - Bq)\epsilon w_1 \tag{5.2a}$$

$$\text{s.t.} \quad w_1 \geq 0$$

$$\max_{w_2} \quad (a - b(w_1 + w_2))w_2 - (A - Bq)\epsilon w_2 \tag{5.2b}$$

$$\text{s.t.} \quad w_2 \geq 0$$

For both water suppliers, there is only one common constraint, that is, their power demand does not exceed power supply.

$$\epsilon(w_1 + w_2) \leq q \quad (\lambda_2) \tag{5.2c}$$

5.2 Solution Approach

Following the same approach of the previous model, we have the following Lagrangian functions and KKT conditions:

The Lagrangian functions of (5.1) and (5.2) are:

$$L_1(q, \lambda_1) = (A - Bq)q - (a - b(w_1 + w_2))\psi q - \lambda_1(\psi q - (w_1 + w_2))$$

$$L_2(w_1, \lambda_2) = (a - b(w_1 + w_2))w_1 - (A - Bq)\epsilon w_1 - \lambda_2(\epsilon(w_1 + w_2) - q)$$

$$L_3(w_2, \lambda_2) = (a - b(w_1 + w_2))w_2 - (A - Bq)\epsilon w_2 - \lambda_2(\epsilon(w_1 + w_2) - q)$$

and the KKT conditions are:

$$0 \leq q \quad \perp \quad A - 2Bq - (a - b(w_1 + w_2))\psi - \psi\lambda_1 \leq 0$$

$$0 \leq w_1 \quad \perp \quad a - 2bw_1 - bw_2 - (A - Bq)\epsilon - \epsilon\lambda_2 \leq 0$$

$$0 \leq w_2 \quad \perp \quad a - bw_1 - 2bw_2 - (A - Bq)\epsilon - \epsilon\lambda_2 \leq 0$$

$$0 \leq \lambda_1 \quad \perp \quad \psi q - (w_1 + w_2) \leq 0$$

$$0 \leq \lambda_2 \quad \perp \quad \epsilon(w_1 + w_2) - q \leq 0$$

As in the first model, λ_1 and λ_2 , are the shadow prices of water and power, respectively. The conditions are reproduced in Appendix C in a different form for later derivations.

5.3 Equilibrium Analysis

In this model, we focus our attention on the effect of competition on the supply chain. Considering only the cases with positive outputs of the power supplier and the water suppliers, we have these three cases discussed in Propositions 4, 5 and 6.

Proposition 4. *(Equilibrium of case II-1, normal case)*

When there are one power supplier and two identical water suppliers, and demand of water and power is less than their supply, if

$$\psi\epsilon < 1 \text{ and } \frac{\epsilon(b\psi + (2 - \epsilon\psi)2B\epsilon)}{2B\epsilon^2 + (3 - 2\epsilon\psi)b} \leq \frac{A\epsilon}{a} \leq \frac{\epsilon(b\psi^2 + (4 - 2\epsilon\psi)B)}{2B\epsilon + (3 - 2\epsilon\psi)b\psi},$$

the following is a positive NE:

$$w_1^{2,1} = w_2^{2,1} = \frac{A\epsilon - a(2 - \epsilon\psi)}{2b(\epsilon\psi - 3)} > 0$$

$$q^{2,1} = \frac{a\psi - A(3 - 2\epsilon\psi)}{2B(\epsilon\psi - 3)} > 0,$$

and the dual variables,

$$\lambda_1^{2,1} = \lambda_2^{2,1} = 0$$

Both consumers buy water and power from the markets. The proof is given in Appendix C.1.

As shown in Appendix C.4, the profits of firms, consumer surplus and social welfare are all positive.

Proposition 5. (Equilibrium of case II-2)

When there are one power supplier and two identical water suppliers, and water demand equals water supply, if

$$\psi\epsilon < 1, \quad \frac{B\epsilon}{b\psi} < \frac{3}{2} \quad \text{and} \quad \frac{\epsilon(b\psi^2 + (4 - 2\epsilon\psi)B)}{2B\epsilon + (3 - 2\epsilon\psi)b\psi} < \frac{A\epsilon}{a} < 1 \quad (\text{case II} - 2.A), \quad \text{or}$$

$$\psi\epsilon < 1, \quad \frac{B\epsilon}{b\psi} > \frac{3}{2} \quad \text{and} \quad 1 < \frac{A\epsilon}{a} < \frac{\epsilon(b\psi^2 + (4 - 2\epsilon\psi)B)}{2B\epsilon + (3 - 2\epsilon\psi)b\psi} \quad (\text{case II} - 2.B),$$

the following is a positive NE:

$$q^{2,2} = \frac{2(A\epsilon - a)}{2B\epsilon - 3b\psi} > 0$$

$$w_1^{2,2} = w_2^{2,2} = \frac{\psi(A\epsilon - a)}{2B\epsilon - 3b\psi} > 0,$$

and the dual variables,

$$\lambda_1^{2,2} = \frac{4Ba - 2AB\epsilon - 3Ab\psi + ab\psi^2 + 2Abe\psi^2 - 2Ba\epsilon\psi}{\psi(2B\epsilon - 3b\psi)} > 0$$

$$\lambda_2^{2,2} = 0$$

The water output is bought entirely by the power supplier, and the other water consumers do not buy any water. The proof is given in Appendix C.2.

In this case, the water suppliers use only $\epsilon(w_1 + w_2)$ MWh of the power produced, and the remaining is bought by the consumers at the power market. Similar to case I-2, this case has two regions, which depend on the parameters of the water and power prices. In either of the regions, the power supplier's output is restricted by the water available in the water market, and every additional gallon of water produced contributes $\lambda_1^{2,2}$ dollars to the power supplier's profit. Case II-3 is symmetric to case II-2, and the results are shown in Proposition 6. It can be shown that the profits, consumer and producer surpluses and social welfare of cases II-2 and II-3 are all positive. The values are shown in Appendix C.4.

Proposition 6. (Equilibrium of case II-3)

When there are one power supplier and two identical water suppliers, and power demand equals power supply, if

$$\psi\epsilon < 1, \quad \frac{B\epsilon}{b\psi} < \frac{1}{2} \quad \text{and} \quad \epsilon\psi < \frac{A\epsilon}{a} < \frac{\epsilon(b\psi + (2 - \epsilon\psi)2B\epsilon)}{(2B\epsilon^2 + (3 - 2\epsilon\psi)b)} \quad (\text{case II} - 3.A), \quad \text{or}$$

$$\psi\epsilon < 1, \quad \frac{B\epsilon}{b\psi} > \frac{1}{2} \quad \text{and} \quad \frac{\epsilon(b\psi + (2 - \epsilon\psi)2B\epsilon)}{(2B\epsilon^2 + (3 - 2\epsilon\psi)b)} < \frac{A\epsilon}{a} < \epsilon\psi, \text{ (case II - 3.B),}$$

the following is a positive NE:

$$q^{2,3} = \frac{\epsilon(A - a\psi)}{2B\epsilon - b\psi} > 0$$

$$w_1^{2,3} = w_2^{2,3} = \frac{A - a\psi}{2(2B\epsilon - b\psi)} > 0,$$

and the dual variables,

$$\lambda_1^{2,3} = 0$$

$$\lambda_2^{2,3} = -\frac{3Ab - 4Ba\epsilon - ab\psi + 2AB\epsilon^2 + 2Ba\epsilon^2\psi - 2Abe\psi}{2\epsilon(2B\epsilon - b\psi)} > 0$$

The power output is bought entirely by the water supplier, and the consumers do not buy any power. The proof is given in Appendix C.3.

The domain of the Equilibrium solutions of this model is similar to that of Model I (Figure 5.2).

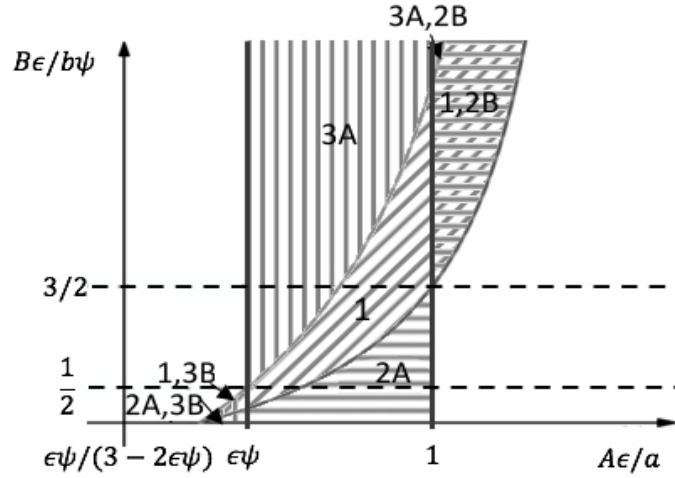

Figure 5.2: Equilibria domains of the water-energy nexus with Cournot competition

5.4 Effect of Cournot Competition in Duopoly Markets

As compared with the results of model I, the newly introduced Cournot competition affects the equilibria and economic measures.

Proposition 7. (*Effect of Cournot competition on the equilibrium outputs, case 1*)

The outputs of the supply chain when there is a Cournot competition in one industry are always greater than those with monopoly firms in normal cases (cases I-1, II-1) when the input conditions of both Propositions 1 and 4 are met.

Proof:

From Propositions 1 and 4, we get

$$q^{2,1} - q^{1,1} = -\frac{\psi (A\epsilon - a(2 - \epsilon\psi))}{2B(\epsilon^2\psi^2 - 7\epsilon\psi + 12)} > 0$$

$$\sum w^{2,1} - w^{1,1} = -\frac{A\epsilon - a(2 - \epsilon\psi)}{b(\epsilon^2\psi^2 - 7\epsilon\psi + 12)} > 0,$$

Here, the denominators are positive since $\epsilon\psi < 1$. The numerators are positive when $A\epsilon/a < 2 - \epsilon\psi$, which is always true from the positivity conditions of the equilibrium values (q and w) of Propositions 1 and 4 \square

Comparing cases I-1 and II-1 (normal cases), we find that competition in one market (e.g., water market) increases not only the output of its own market, but also the output of the other market (e.g., power market). The increased output by the Cournot firms decreases the price of Cournot commodity, which in turn, entices the firm in the other market to produce more. In this case, the power supplier takes advantage of the reduced cost of water due to the competition between the water suppliers and increases his production.

Proposition 8. *(Effect of Cournot competition on the producer and consumer surplus, case 1)*

When production quantities are large enough to serve all customers in both markets in cases I-1 (water monopoly) and II-1 (water duopoly), i.e., normal cases, and when both input conditions of Propositions 1 and 4 are met:

- $CS_p^{2,1} > CS_p^{1,1}$, $CS_w^{2,1} > CS_w^{1,1}$
- $PS_p^{2,1} > PS_p^{1,1}$
- $PS_w^{2,1} > PS_w^{1,1}$ iff $\epsilon\psi > 2 - \sqrt{2}$

The proofs are given in Appendices C.5-C.8.

In classic Cournot competitions, the total output produced by the firms increases with the increased number of competitors; hence, the consumer surplus rises and the producer surplus declines. However, it is not always the case in this supply chain. The third bullet of the proposition shows that when the supply chain is less efficient (large $\epsilon\psi$), all firms are better off with Cournot competition. In such a case, a monopolist water supplier would be enticed to split into two water suppliers and capture this surplus increase. On the other hand, if the supply chain is more efficient (small $\epsilon\psi$), the water suppliers may be induced to merge or form a cartel to capture a higher profit. The producers and the consumers of the power industry enjoy greater surpluses even though the competition takes place in the cross-industry, the water industry in this case, because the power supplier's cost decreases, allowing it to increase production.

Different from the results of Proposition 8, which considers the normal cases with enough outputs for the consumers in both markets, when one industry captures all the outputs of the other industry, Cournot competition does not always lead to better outputs and welfare. The following proposition shows the effect of water market competition on the total outputs of the supply chain under this condition.

Proposition 9. *(Effect of Cournot competition on the equilibrium outputs, producer and consumer surplus and social welfare, case 2)*

When the power industry consumes all water produced, the outputs of the supply chain, producer surpluses, consumer surpluses and social welfare increase when there is competition in the water market if $A\epsilon/a < 1$, and they decrease otherwise if both input conditions of

Propositions 2 and 5 are met.

Proof:

From Propositions 2 and 5,

$$q^{2,2} - q^{1,2} > 0 \text{ and } \sum w^{2,2} - w^{1,2} > 0 \text{ iff } \frac{A\epsilon}{a} < 1$$

Also,

$$PS_p^{2,2} - PS_p^{1,2}, PS_w^{2,2} - PS_w^{1,2}, CS_p^{2,2} - CS_p^{1,2}, SW^{2,2} - SW^{1,2} > 0 \text{ iff } \frac{A\epsilon}{a} < 1 \quad \square$$

Proposition 10. *(Effect of Cournot competition on the equilibrium outputs, producer and consumer surplus and social welfare, case 3)*

When the water industry consumes all power produced (cases I-3 and II-3), the new competition in the water market does not change the outputs, producer and consumer surpluses and social welfare of the supply chain when both input conditions of Propositions 3 and 6 are met.

Proof:

From Propositions 3 and 6,

$$q^{2,3} = q^{1,3} \text{ and } \sum w^{2,3} = w^{1,3}$$

$$PS_p^{2,3} = PS_p^{1,3}, PS_w^{2,3} = PS_w^{1,3}, CS_p^{2,3} = CS_p^{1,3}, SW^{2,3} = SW^{1,3} \quad \square$$

The result is intuitive; if the demand of the water industry for power could not be met when

there is only one water supplier, more water suppliers will not change the situation. As shown above, all the economic measures remain unchanged with and without competition.

CHAPTER 6:

MODEL III: MULTIPLE POWER SUPPLIERS AND MULTIPLE WATER SUPPLIERS

6.1 Introduction

In this section, we generalize the conditions of the supply chain to include multiple power suppliers and multiple water suppliers, as shown in Figure 6.1. In this model, the firms and their products in the same industry are identical. They also compete for production quantity and aim to maximize their own profits.

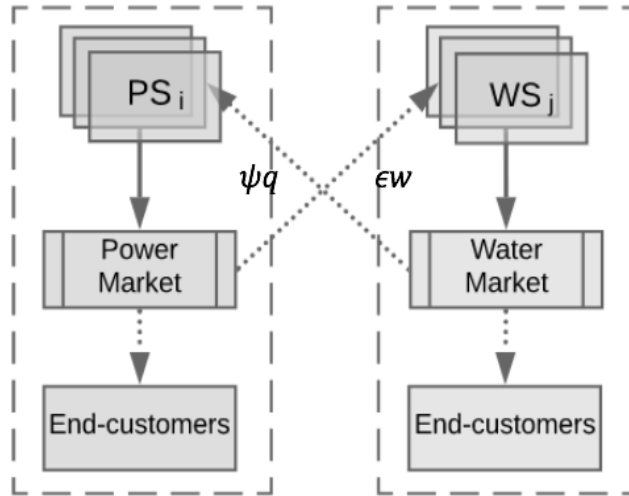

Figure 6.1: Water-energy nexus of Model III

Here, the prices of power and water are given by $p^p = A - B(q_0 + \sum_i^n q_i)$ and $p^w = a - b(w_0 + \sum_j^m w_j)$, respectively. q_0 and w_0 represent the existing firms, and i and j represent

the rival firms. Since all firms in the same industry are identical, we let $p^p = A - B(q_0 + nq_1)$ and $p^w = a - b(w_0 + mw_1)$. There are $n + 1$ power suppliers and $m + 1$ water suppliers in the supply chain. Since the rival firms are identical, we reformulate the problems as shown in equation (6.1). Equation (6.1) represents the profit maximizing problem of the existing power supplier, which is identical for the other n power suppliers. The constraint is a demand and supply constraint.

$$\begin{aligned}
\max_{q_0} \quad & (A - B(q_0 + nq_1))q_0 - (a - b(w_0 + mw_1))\psi q_0 \\
\text{s.t.} \quad & \psi(q_0 + nq_1) \leq (w_0 + mw_1) \quad (\lambda_1) \\
& q_0 \geq 0
\end{aligned} \tag{6.1}$$

Similarly, we have the profit maximizing problem of the existing water supplier as follows:

$$\begin{aligned}
\max_{w_0} \quad & (a - b(w_0 + mw_1))w_0 - (A - B(q_0 + nq_1))\epsilon w_0 \\
\text{s.t.} \quad & \epsilon(w_0 + mw_1) \leq (q_0 + nq_1) \quad (\lambda_2) \\
& w_0 \geq 0
\end{aligned} \tag{6.2}$$

6.2 Solution Approach

The KKT conditions are used to solve this problem. The Lagrangian Functions of problems (6.1) and (6.2) are:

$$\begin{aligned}
L_1(q_0, \lambda_1) &= (A - B(q_0 + nq_1))q_0 - (a - b(w_0 + mw_1))\psi q_0 - \lambda_1(\psi(q_0 + nq_1) - (w_0 + mw_1)) \\
L_2(w_0, \lambda_2) &= (a - b(w_0 + mw_1))w_0 - (A - B(q_0 + nq_1))\epsilon w_0 - \lambda_2(\epsilon(w_0 + mw_1) - (q_0 + nq_1)),
\end{aligned}$$

and the KKT conditions are:

$$\begin{aligned}
0 &\leq q_0 \perp A - 2Bq_0 - Bnq_1 - (a - b(w_0 + mw_1))\psi - \psi\lambda_1 \leq 0 \\
0 &\leq w_0 \perp a - 2bw_0 - bmw_1 - (A - B(q_0 + nq_1))\epsilon - \epsilon\lambda_2 \leq 0 \\
0 &\leq \lambda_1 \perp \psi(q_0 + nq_1) - (w_0 + mw_1) \leq 0 \\
0 &\leq \lambda_2 \perp \epsilon(w_0 + mw_1) - (q_0 + nq_1) \leq 0
\end{aligned}$$

After defining the KKT conditions, we replace q_1 and w_1 with q_0 and w_0 , respectively, and proceed with the same solution procedure followed in Model I and Model II.

6.3 Equilibrium Analysis

Based on the above set of KKT conditions above, there can be $2^{(n+m+4)}$ possible cases to consider based on the positivity of the primal and dual variables. In this analysis, we consider only the cases where the firms produce positive outputs and are profitable; which comes down to three possible cases. Since all firms in their respected industry are identical, the analysis is conducted for the existing firms.

Proposition 11. (*Equilibrium of case III-1, normal case*)

When there are $n + 1$ power suppliers and $m + 1$ water suppliers, and demand of water and power is less than their supply, if

$$\begin{aligned}
\frac{\epsilon(2B\epsilon + b\psi + 2B\epsilon m + B\epsilon n + bn\psi - B\epsilon^2\psi - B\epsilon^2m\psi - B\epsilon^2n\psi + B\epsilon mn - B\epsilon^2mn\psi)}{2b + bm + 2bn + B\epsilon^2 - b\epsilon\psi + bm n + B\epsilon^2m - b\epsilon m\psi - b\epsilon n\psi - b\epsilon mn\psi} &\leq \frac{A\epsilon}{a} \leq \\
\frac{\epsilon(2B + 2Bm + Bn + b\psi^2 - B\epsilon\psi + Bmn + bn\psi^2 - B\epsilon m\psi - B\epsilon n\psi - B\epsilon mn\psi)}{B\epsilon + 2b\psi + B\epsilon m + bm\psi + 2bn\psi - b\epsilon\psi^2 + bm n\psi - b\epsilon m\psi^2 - b\epsilon n\psi^2 - b\epsilon mn\psi^2} &
\end{aligned}$$

the following is a positive NE:

$$q_0^{3,1} = \frac{-a\psi + Am + 2A - A\epsilon\psi - A\epsilon m\psi}{B(2m + 2n - \epsilon\psi + mn - \epsilon m\psi - \epsilon n\psi - \epsilon mn\psi + 4)}$$

$$w_0^{3,1} = \frac{-A\epsilon + 2a + an - a\epsilon\psi - a\epsilon n\psi}{b(2m + 2n - \epsilon\psi + mn - \epsilon m\psi - \epsilon n\psi - \epsilon mn\psi + 4)}$$

At this NE, the firms produce enough output to meet the demand of the firms in the cross-industry as well as the demand of the consumers in their respective industry. The economic measures of cases III-1,2,3 are shown in Appendix D.1.

Proposition 12. (*Equilibrium of case III-2*)

When there are $n + 1$ power suppliers and $m + 1$ water suppliers, and water demand equals water supply, if

Case III-2.A:

$$\frac{B\epsilon}{b\psi} < \frac{m+2}{m+1} \text{ and}$$

$$\frac{\epsilon(2B + 2Bm + Bn + b\psi^2 - B\epsilon\psi + Bmn + bn\psi^2 - B\epsilon m\psi - B\epsilon n\psi - B\epsilon mn\psi)}{B\epsilon + 2b\psi + B\epsilon m + b m\psi + 2bn\psi - b\epsilon\psi^2 + bmn\psi - b\epsilon m\psi^2 - b\epsilon n\psi^2 - b\epsilon mn\psi^2} < \frac{A\epsilon}{a} < 1$$

Case III-2.B:

$$\frac{B\epsilon}{b\psi} > \frac{m+2}{m+1} \text{ and}$$

$$1 < \frac{A\epsilon}{a} < \frac{\epsilon(2B + 2Bm + Bn + b\psi^2 - B\epsilon\psi + Bmn + bn\psi^2 - B\epsilon m\psi - B\epsilon n\psi - B\epsilon mn\psi)}{B\epsilon + 2b\psi + B\epsilon m + b m\psi + 2bn\psi - b\epsilon\psi^2 + bmn\psi - b\epsilon m\psi^2 - b\epsilon n\psi^2 - b\epsilon mn\psi^2}$$

the following is a positive NE:

$$q_0^{3,2} = \frac{(m+1)(A\epsilon - a)}{(n+1)(B\epsilon - 2b\psi + B\epsilon m - b m\psi)}$$

$$w_0^{3,2} = \frac{(A\epsilon - a)\psi}{B\epsilon - 2b\psi + B\epsilon m - b m\psi},$$

and the water market is entirely bought by the power suppliers.

The consumers of the water market, except for the power suppliers, do not buy any water. On the other hand, the power industry produces more than the demand of the water suppliers. In this case, there are two possible subcases depending on the values of the technology efficiency and the conditions of the markets.

Proposition 13. (Equilibrium of case III-3)

When there are $n + 1$ power suppliers and $m + 1$ water suppliers, and power demand equals power supply, if

Case III-3.A:

$$\frac{B\epsilon}{b\psi} < \frac{n+1}{n+2} \text{ and}$$

$$\epsilon\psi < \frac{A\epsilon}{a} < \frac{\epsilon(2B\epsilon + b\psi + 2B\epsilon m + B\epsilon n + bn\psi - B\epsilon^2\psi - B\epsilon^2m\psi - B\epsilon^2n\psi + B\epsilon mn - B\epsilon^2mn\psi)}{2b + bm + 2bn + B\epsilon^2 - b\epsilon\psi + bmn + B\epsilon^2m - b\epsilon m\psi - b\epsilon n\psi - b\epsilon mn\psi}$$

Case III-3.B:

$$\frac{B\epsilon}{b\psi} > \frac{n+1}{n+2} \text{ and}$$

$$\frac{\epsilon(2B\epsilon + b\psi + 2B\epsilon m + B\epsilon n + bn\psi - B\epsilon^2\psi - B\epsilon^2m\psi - B\epsilon^2n\psi + B\epsilon mn - B\epsilon^2mn\psi)}{2b + bm + 2bn + B\epsilon^2 - b\epsilon\psi + bmn + B\epsilon^2m - b\epsilon m\psi - b\epsilon n\psi - b\epsilon mn\psi} < \frac{A\epsilon}{a} < \epsilon\psi$$

the following is a positive NE:

$$q_0^{3,3} = \frac{(A - a\psi)\epsilon}{2B\epsilon - b\psi + B\epsilon n - bn\psi}$$

$$w_0^{3,3} = \frac{(n+1)(A - a\psi)}{(m+1)(2B\epsilon - b\psi + B\epsilon n - bn\psi)},$$

and the power market is entirely bought by the water suppliers.

This case is symmetric to case III-2. The water suppliers buy all power produced, while the power suppliers buy some of the water produced and the rest of water is sold to the other consumers. There are also two possible subcases in this case, depending on the values of the reservation prices, technology efficiency and the elasticities of the demands.

Putting the three cases discussed above together, we see similar unique and multiple equilibria patterns as shown in models I and II, but the domain lines become straighter, and the lines dividing cases III-2 and III-3 intersect the y-axis at $\frac{m+2}{m+1}$ and $\frac{n+1}{n+2}$, respectively. Unique Nash equilibria occur when $\epsilon\psi < A\epsilon/a < 1$, that is, when the marginal revenue cuts the marginal cost from above. On the other hand, we have four multiple equilibria: two in region B of case III-2 and two in region B of case III-3. If any of the cases III-1, III-2A or III-3A is one of the equilibria, that case is the Pareto optimal decision.

6.4 Effect of Cournot Competition in Oligopoly Markets

This section discusses the effect of increased competition on the domains of the input conditions, the equilibrium outputs, the producer and consumer surpluses and the social welfare. Figure 6.2 illustrates the input conditions of Model I (dashed) and Model III (solid). The figure shows that, as the number of competitors in either of the two industries increases, the thresholds that divide regions A and B of cases III-2 and III-3 approach 1. Also, the x-intercept of the hyperbola curves approaches zero with more competitions. These effects cause the hyperbola curves to be straighter and the types of domains of some regions to be changed. For example, the case of the star-marked point in the figure is changed from case I-2A (water consumers do not buy water) to case III-1 (all customers buy water and power).

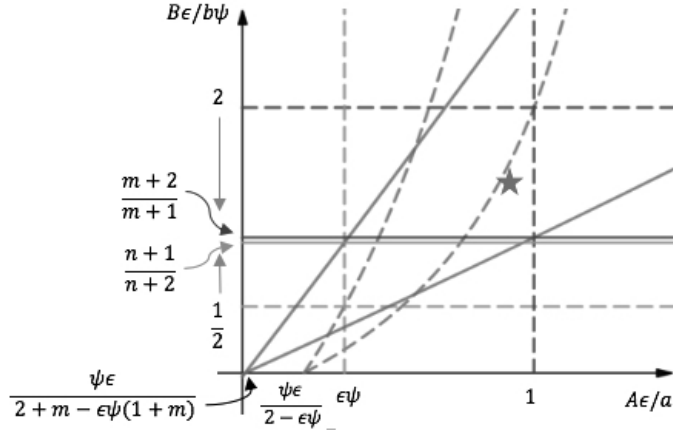

Figure 6.2: Effect of competition on the domains

In the rest of this section, we study the effect of competition on the NE outputs, profits, consumer surplus and social welfare. We first discuss the effect of competition on case III-1 followed by case III-2.

Proposition 14. *(Effect of Cournot competition on the equilibrium outputs, consumer surplus and profits, case III-1, the normal case)*

In a supply chain with multiple power suppliers and multiple water suppliers,

(a) *More Cournot competition in one market increases not only the total output and consumer surplus of the same market, but also those of the cross-market.*

$$i) \frac{\partial Q^{3,1}}{\partial n} > 0, \quad ii) \frac{\partial Q^{3,1}}{\partial m} > 0, \quad iii) \frac{\partial CS_p^{3,1}}{\partial n} > 0, \quad iv) \frac{\partial CS_p^{3,1}}{\partial m} > 0$$

(b) *More Cournot competition in one market decreases the individual outputs and profits of the firms in the same market, but increases the individual outputs and profits of the*

firms of the cross-market.

$$i) \frac{\partial q_i^{3,1}}{\partial n} < 0, \quad ii) \frac{\partial \pi_{p,i}^{3,1}}{\partial n} < 0, \quad iii) \frac{\partial q_i^{3,1}}{\partial m} > 0, \quad iv) \frac{\partial \pi_{p,i}^{3,1}}{\partial m} > 0$$

The proofs are shown in Appendices D.2-D.6.

It is intuitive that the total output of a market is increased (a-*i*), the output of individual firm is decreased (b-*i*) and profit of each firm is reduced (b-*ii*) when more competitors enter that market. However, we observe that Cournot competition in one market leads to increased output of the cross-market (a-*ii*). We also observe that, although the individual output is reduced when more firms enter a market, the individual firms in the cross-market produce more (b-*iii*) and earn higher profits (b-*iv*). It can be because the decreased price due to competition makes the production of the firms in the cross-industry more efficient. The consumers of both markets enjoy higher welfare when more firms enter either of the markets (a-*iii* and a-*iv*).

Proposition 15. (*Effect of Cournot competition on the producer surplus, case III-1, normal case*)

In a supply chain with multiple power suppliers and multiple water suppliers when the consumers buy water and power, more Cournot competition in one market may increase or decrease the producer surplus of the same industry, but always increases the producer surplus

of the cross-industry.

$$\begin{aligned}
i) \quad & \frac{\partial PS_p^{3,1}}{\partial n} < 0 \text{ iff } \epsilon\psi < \frac{2n + nm}{1 + n + m + nm} \\
ii) \quad & \frac{\partial PS_w^{3,1}}{\partial m} < 0 \text{ iff } \epsilon\psi < \frac{2m + nm}{1 + n + m + nm} \\
iii) \quad & \frac{\partial PS_p^{3,1}}{\partial m} > 0 \text{ and } \frac{\partial PS_w^{3,1}}{\partial n} > 0
\end{aligned}$$

From Proposition 15, the producer surplus of the entered market may increase or decrease depending on the value of the overall efficiency of the supply chain and the number of firms in the two markets. If there is at least one firm more in a market than in the cross-market (i.e., $n \geq 1 + m$), the right-hand sides of the conditions are larger than one and the producer surplus always decreases with the increase of competition in that market because $\epsilon\psi < 1$; otherwise the producer surplus may increase or decrease.

The effect of the number of firms on the social welfare is complicated to present as an equation. Thus, we show it graphically (Figure 6.3). Setting the derivative of the effect of the number of firms on the social welfare to zero and solving for $A\epsilon/a$, we obtain the curves on the far right and far left of the figure. The figure shows the area where the social welfare increases. Since the input conditions of case III-1 (i.e., the area between the solid lines) fall in the shaded area, the social welfare always increases with competition in either of the markets.

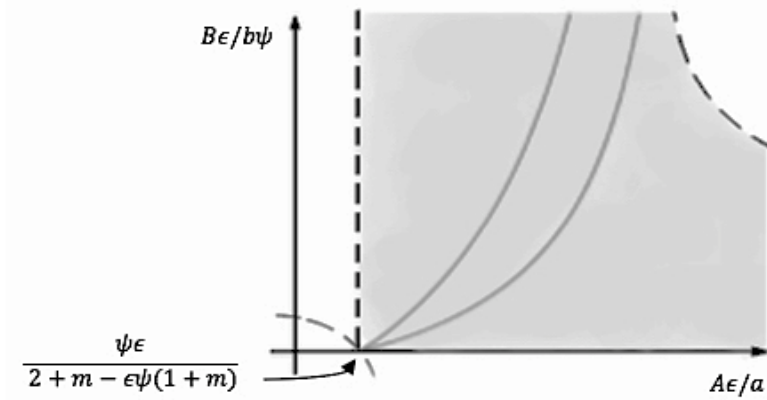

Figure 6.3: The domain of increased social welfare with more power suppliers in case III-1

In the following propositions, we show the effect of competition in case III-2, where all the water is captured by the power suppliers.

Proposition 16. (*Effect of Cournot competition on the total outputs, producer and consumer surplus and social welfare, case III-2*)

In a supply chain with multiple power suppliers and multiple water suppliers, when the power industry buys all the water produced,

- (a) *Cournot competition in the industry that consumes all the outputs of the cross-industry has no effect on the total output, the consumer surplus, the producer surplus or the social welfare of either industry.*

$$\frac{\partial Q^{3,2}}{\partial n} = \frac{\partial W^{3,2}}{\partial n} = \frac{\partial CS_p^{3,2}}{\partial n} = \frac{\partial CS_w^{3,2}}{\partial n} = \frac{\partial PS_p^{3,2}}{\partial n} = \frac{\partial PS_w^{3,2}}{\partial n} = \frac{\partial SW^{3,2}}{\partial n} = 0,$$

- (b) *Cournot competition in the consumed industry can have a positive or negative effect on the economic measures depending on the market conditions.*

$$\text{In case III-2.A: } \frac{\partial Q^{3,2}}{\partial m}, \frac{\partial W^{3,2}}{\partial m}, \frac{\partial CS_p^{3,2}}{\partial m}, \frac{\partial CS_w^{3,2}}{\partial m}, \frac{\partial PS_p^{3,2}}{\partial m}, \frac{\partial PS_w^{3,2}}{\partial m}, \frac{\partial SW^{3,2}}{\partial m} > 0$$

$$\text{In case III-2.B: } \frac{\partial Q^{3,2}}{\partial m}, \frac{\partial W^{3,2}}{\partial m}, \frac{\partial CS_p^{3,2}}{\partial m}, \frac{\partial CS_w^{3,2}}{\partial m}, \frac{\partial PS_p^{3,2}}{\partial m}, \frac{\partial PS_w^{3,2}}{\partial m}, \frac{\partial SW^{3,2}}{\partial m} < 0$$

In the first part of Proposition 16, more firms in the power industry do not help or hurt the water industry because the power industry is constrained by the water supply. The second part of the proposition shows that competition in the water industry may have a positive or negative impact on the economics measures. If marginal revenue cuts the marginal cost from above (case III-2.A), the total outputs, consumer surpluses and producer surpluses of both industries increase; but they decrease if the marginal revenue cuts the marginal cost from below (case III-2.B).

Proposition 17. (*Effect of Cournot competition on the individual outputs, case III-2*)

In a supply chain with multiple power suppliers and multiple water suppliers, when the power industry buys all the water produced,

(a) *The outputs of the individual power suppliers may increase or decrease with more competition in the water industry*

$$\text{In case III-2.A: } \frac{\partial q_i^{3,2}}{\partial m} > 0$$

$$\text{In case III-2.B: } \frac{\partial q_i^{3,2}}{\partial m} < 0$$

(b) *The outputs of the water suppliers increase with competition in the water industry*

$$\frac{\partial w_i^{3,2}}{\partial m} > 0 \text{ if } \frac{A\epsilon}{a} < 1 \text{ and } \frac{B\epsilon}{b\psi} > 1$$

The proofs are given in Appendices D.7 and D.8.

In case III-2, the increased competition in the water industry leads to different effects on the output of each firm. For the power suppliers (the dominating industry), the individual outputs increase in case III-2.A and decrease in case III-2.B. However, the effect of increasing competition on the water suppliers is counterintuitive because competition decreases the individual outputs of the competing firms. In this case, the outputs of the water suppliers increase if $\frac{A\epsilon}{a} < 1$ and $\frac{B\epsilon}{b\psi} > 1$ (Figure 6.4).

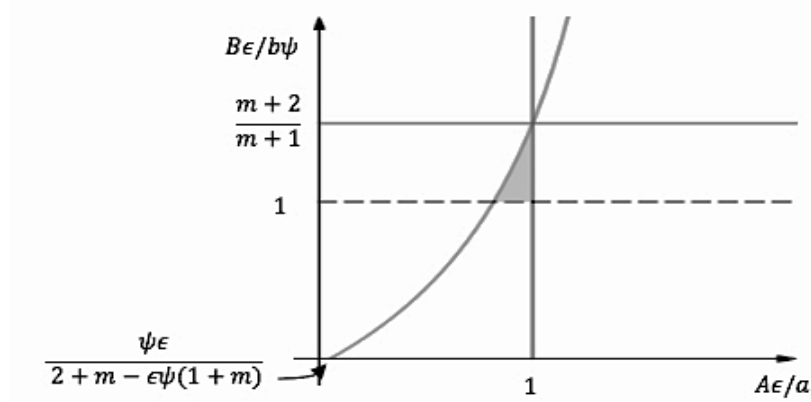

Figure 6.4: Domain space where water suppliers increase individual outputs with higher competition

CHAPTER 7:

MODEL IV: MULTIPLE NON-IDENTICAL POWER SUPPLIERS AND MULTIPLE NON-IDENTICAL WATER SUPPLIERS

7.1 Introduction

In this model, there are multiple non-identical firms in each industry of the water-energy supply chain. Some firms are more efficient than others due to the different technologies they employ (see Figure 7.1). For example, some power plants use open-loop cooling systems that have higher withdrawal, but lower consumption rate; while others use wet-cooling systems that have lower withdrawal, but higher consumption rates. Also, these firms may have different capacity constraints (physical constraint due to the size of the supplier or regulatory constraints such as carbon emission caps).

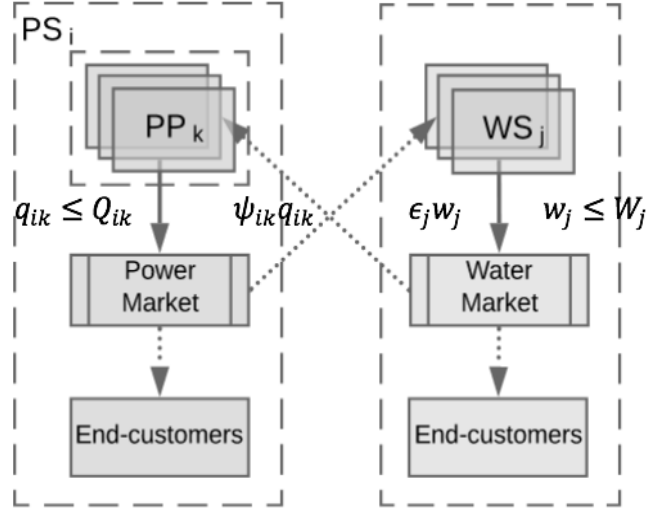

Figure 7.1: Water-energy nexus of Model IV

Since power suppliers may own more than one power generator with different energy sources, they make their decision of the quantity to produce by each power generator, q_{ik} . The objective of the power supplier is to maximize its own profit. The market price of electricity is determined by the inverse demand function, $A - B \sum_i^n \sum_k q_{ik}$ [54–56]. A and B represent the reservation price of electricity and the unit price of power produced. We consider the cost incurred in the short run, which is the cost of water acquisition. Power plants have capacity limits equal to Q_{ik} , which can be physical (e.g., size of power generation unit) or regulatory (e.g., CO2 emission quota imposed). The maximizing profit problem of each power supplier becomes the following:

$$\begin{aligned}
 \max_{q_{ik}} \quad & \left(A - B \sum_i^n \sum_k q_{ik} \right) \sum_k q_{ik} - \left(a - b \sum_j^m w_j \right) \sum_k \psi_{ik} q_{ik} \quad \forall i \\
 \text{s.t.} \quad & q_{ik} \leq Q_{ik}
 \end{aligned} \tag{7.1}$$

In the water industry, the water suppliers also aim to maximize their own profits as well. The revenues of the water suppliers incur by selling water to power suppliers and end consumers,

and the cost is the cost of purchasing electricity from the power industry. There are three types of water users, residential, agricultural, and commercial and industrial, and each user prices water differently [57, 58]. That is because there are different factors that affect the price of water. Worthington (2010) modeled the demand of water for commercial and industrial users as a function of the cost of input resources (including water), its production quantity, cost shares and other independent variables [57]. Another study modeled the water price for industrial users as a function of its water consumption, entity size (based on the number of employees) and the type of industry [58].

In this model, we assume that the water price follows the inverse demand function of water, $a - b \sum w_i$, in which the parameter a incorporates all the factors except for the unit price of water, b . The water price is affected by the total output of all firms. There are different types of water suppliers based on the level and technology of water treatment, such as a desalination plant and a wastewater treatment plant. In this model, a water supplier owns one water treatment unit. Water suppliers also have capacity limits equal to W_j . The profit-maximizing problem of the water supplier is shown in formulation 7.2.

$$\begin{aligned} \max_{w_j} \quad & \left(a - b \sum_j^m w_j \right) w_j - \left(A - B \sum_i^n \sum_k q_{ik} \right) \epsilon_j w_j \quad \forall j \\ \text{s.t.} \quad & w_j \leq W_j \end{aligned} \quad (7.2)$$

These two industries also have common constraints: the consumption of a commodity cannot exceed its supply, which is shown in constraints 7.3 and 7.4 for the power and water industry, respectively.

$$\sum_i^n \sum_k \psi_{ik} q_{ik} \leq \sum_j^m w_j \quad (7.3)$$

$$\sum_j^m \epsilon_j w_j \leq \sum_i^n \sum_k q_{ik} \quad (7.4)$$

Based on this model, we determine the equilibrium production quantities of electricity and water and perform sensitivity analysis on some of the critical parameters.

7.2 Solution Approach

The water-energy nexus problem discussed above is an economic model that is classified as an equilibrium problem. After transforming the problem to a set of KKT conditions as shown below, it can be considered a complementarity problem [59], more specifically, a mixed complementarity problem (MCP). MCP is a special case of the complementarity problems that involves a mix of equalities and inequalities.

When the problem is small, it can be solved analytically and can produce a closed-form solution by solving all possible combinations of primary and dual variables (see Hamoud and Jang (2019), who analytically solved smaller problems of the water-energy nexus) [60]. However, when the number of variables and constraints increases, they become tedious to solve analytically. Alternatively, commercial solutions such as GAMS with the help of specialized MCP solvers such as NLPEC can solve such problems. Since the solution of KKT conditions is necessary and sufficient, any solution of the above model is a Nash equilibrium (NE), and no firm can gain by unilaterally deviating from the equilibrium. The KKT conditions of the above problems are as follows:

$$\begin{aligned}
0 \leq q_{ik} \perp A - 2B \sum_k q_{ik} - B \sum_{i', i' \neq i} \sum_{k', k' \neq k} q_{i'k'} - \left(a - b \sum_j w_j \right) \psi_{ik} - \psi_{ik} \lambda^w - \mu_{ik}^p &\leq 0 \quad \forall i \in n \\
0 \leq w_j \perp a - 2bw_j - b \sum_{j', j' \neq j} w_j - \left(A - B \sum_i \sum_k q_{ik} \right) \epsilon_j - \sum_j \epsilon_j \lambda^p - \mu_j^w &\leq 0 \quad \forall j \in m \\
0 \leq \mu_{ik}^p \perp q_{ik} - Q_{ik} &\leq 0 \quad \forall i \in n \\
0 \leq \mu_j^w \perp w_j - W_j &\leq 0 \quad \forall j \in m \\
0 \leq \lambda^w \perp \sum_i \sum_k \psi_{ik} q_{ik} - \sum_j w_j &\leq 0 \\
0 \leq \lambda^p \perp \sum_j \epsilon_j w_j - \sum_i \sum_k q_{ik} &\leq 0
\end{aligned}$$

From the complementarity conditions, the variables q_{ik} and w_j complement the first order conditions, and the dual variables ($\mu_{ik}^p, \mu_j^w, \lambda^p$ and λ^w) complement their respective primal constraints. We use λ for the dual variables of the market constraints. Also, μ_i^p and μ_j^w are the shadow prices of the capacity of the respective supplier. If the dual variable of an industry is positive, that industry faces a shortage of inputs caused by the holdup of production by the firms of the cross-industry. For example, if $\lambda^w > 0$, then $\sum_i \sum_k \psi_{ik} q_{ik} = \sum_j w_j$.

7.3 Case Study

7.3.1 Background

Our example is motivated by the PJM market. PJM is a regional transmission operator that coordinates the wholesale of power. Although PJM stands for Pennsylvania-New Jersey-Maryland, it is now one of the world's leading RTOs, connecting 13 states and the District of Columbia and serving around 65 million people. There are different types of participants in PJM, as shown in Figure 7.2. There are two types of companies who buy energy from the market: metered buyers and unmetered buyers. Metered buyers consume the energy in

the PJM market, while unmetered buyers consume it outside the market [61]. Market sellers sell energy in the market, and load serving entities are the utility companies that provide electricity to homes and businesses. A participating company can be one or a mix of the above categories. Finally, a curtailment service provider is a company that limits demand when needed.

In PJM, there are around 200 selling companies with subsidiaries that own one or more power generators. According to data reported by EIA, about 25% of the sold power in the first seven months of 2019 is generated by just 2% of the companies. Some of these major companies are Duke Energy, Dominion Energy and Tennessee Valley Authority. They own around 59, 66 and 73 power stations of different energy sources, respectively. Each power station consists of one or more generation units.

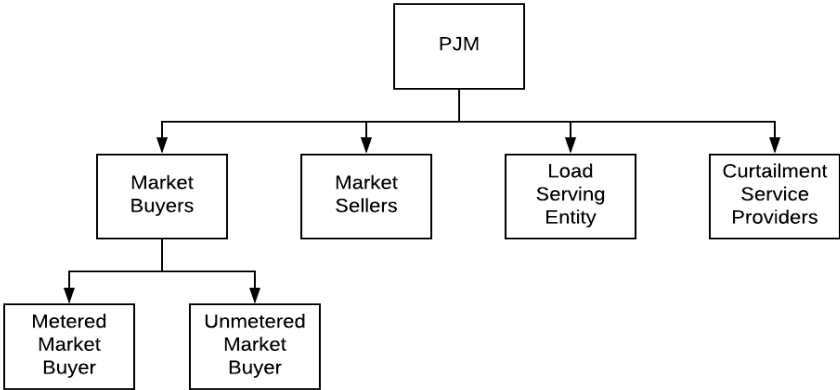

Figure 7.2: PJM market participants

7.3.2 Numerical Example

Due to the lack of detailed data of the capacity limit and efficiency of the power generating units, we develop a numerical example that simplifies the complexity of PJM, yet provides

meaningful insights of the interaction between the firms in a closed-loop water-energy supply chain. In this example, we introduce a duopoly power market and a monopoly water market. These firms have some degree of market power (i.e., price makers) that their production level affects the market price. Furthermore, to make our model computationally possible, the power generating units of each firm are aggregated by their energy sources, e.g., all nuclear power plants of a company are consolidated into one power plant. A number of scenarios with different market conditions are introduced to examine their effects on the equilibrium and other economic measures.

There are multiple factors to consider to determine the water usage of power suppliers. First, the meaning of water usage. Water usage can be referred to water consumption or water withdrawal of a power plant. Second, the technology used for the cooling system, open-loop, recirculated or dry cooling. Third, the energy source of the power supplier. Appendix A shows a combination of these factors with their corresponding consumption and withdrawal rates.

The market price of power is assumed to follow the inverse demand function, $P^p = 50 - 0.02Q$. The slope is chosen arbitrarily, but it is within the range suggested by Chuang et. al. (2001) [56]. Zhang and Vesselinov (2016) show different values of water (ranging from 1.78 to 4.37 $\$/10^3 gal$) depending on the source of water (ground, surface or recycled) and the type of power plants using the water [40]. Stillwell and Webber (2014) claim that reclaimed water in Texas costs power plants from 0.98 to 2.45 $\$/10^3 gal$ [13]. Some of the predominant power plants enjoy lower long-term fixed rates. According to Griffin (2006), price elasticities of water demands are different for different water use purposes [62]. For example, demand for drinking water is less elastic than for others such as irrigation and industrial uses. The price

intercept varies depending on the size of the market. In this study, we set the price intercept and slope of water to 20 $\$/MWh$ and 0.008 $\$/MW^2h$, respectively.

Energy use for water supply depends on the water source (surface or ground) and the type and size of the water suppliers [63]. For example, surface freshwater suppliers may consume energy for water pumping and delivery only, while wastewater treatment plants consume additional energy for multi-stage treatments. In this study, we assume the water supplier has an efficiency factor (ϵ) of 0.002 $MWh/10^3gal$.

7.3.2.1 Identical firms with unlimited capacity scenario (Benchmark)

The benchmark scenario assumes that power plants have the same water efficiency factor (ψ) at the level of 0.47 $10^3gal/MWh$ and have unlimited production capacity. This efficiency factor represents the average water consumption by power plants in the regions covered by PJM¹. The solution shows that they produce an equal amount of output since the power plants are identical in terms of their water consumption efficiency. The analysis shows that there are two Nash equilibria. At one of them, the firms produce zero output, earning zero profits and not contributing to social welfare. In the other equilibrium, each power supplier produces a total amount of 774.5 MWh and the water supplier produces 935,000 gal . Since the power plants have equal efficiency with unlimited capacity, there is indefinite number of equilibria. The power suppliers can use any combination of power plants to generate the same output. This second equilibrium is Pareto optimal since the firms and consumers are better off in the second equilibrium [52, 53]. Since zero production equilibrium is unlikely to be the case in reality, it is not discussed hereafter.

¹Data of the average water consumption of power plants in the US are filtered for the states covered by PJM. It must be noted that 0.47 is approximate since PJM may not cover a state entirely.

Table 7.1: Economic measures of the benchmark scenario

W	Q	PS_w	Π_{p1}	Π_{p2}	PS_p	CS_w	CS_p	SW
935	1549	6996	11995	11995	23990	3498	23990	58473

7.3.2.2 Non-identical firms with unlimited capacity scenario (NIUL)

In this scenario, we assume power plants have different efficiency factors, but still have unlimited production capacity. As discussed above, PJM’s participants may own multiple power plants with different energy sources. In this scenario, we assume that there are three types of power plants, nuclear, coal and natural gas. From Table 3, we arbitrarily pick an efficiency factor for each power plant based on its energy source, as shown in Table 2. The average efficiency of this power plant mix is $0.54 \cdot 10^3 \text{ gal}/MWh$.

Table 7.2: Water efficiency of power plants (ψ)

	PS_1	PS_2
PP_1 (nuclear)	0.672	0.269
PP_2 (coal)	0.687	0.942
PP_3 (natural gas)	0.470	0.198

Since the power plants have no capacity limits, we find that the power suppliers only use their most efficient power plants. However, since PS_1 is less efficient than PS_2 , PS_1 loses some market share to PS_2 . Although the efficiency of PS_1 ’s most efficient power plant is still equal to the efficiency of the benchmark scenario, it produces 4.5% less and loses 9% of its profit. On the other hand, PS_2 produces 8.8% more and enjoys a higher profit of nearly 18%. Since the gain of PS_2 is twice as the loss of PS_1 , the power producer surplus shows an

increase of almost 5%. Being more efficient gives PS_2 a competitive advantage and allows it to capture an additional 3.25% of market share.

Table 7.3: Outputs of power plants in NIUL scenario

PP_{11}	PP_{12}	PP_{13}	PS_1	PP_{21}	PP_{22}	PP_{23}	PS_2
0	0	740	740	0	0	843	843

Due to the usage of the most efficient power plants, the average efficiency improved by 30% from $0.47 \cdot 10^3 \text{ gal}/MWh$ to $0.33 \cdot 10^3 \text{ gal}/MWh$. Hence, the total output of the power suppliers and social welfare increased by 2% and 4%, respectively, compared with the benchmark scenario. Since the demand of water is inelastic, the water supplier's production increased marginally.

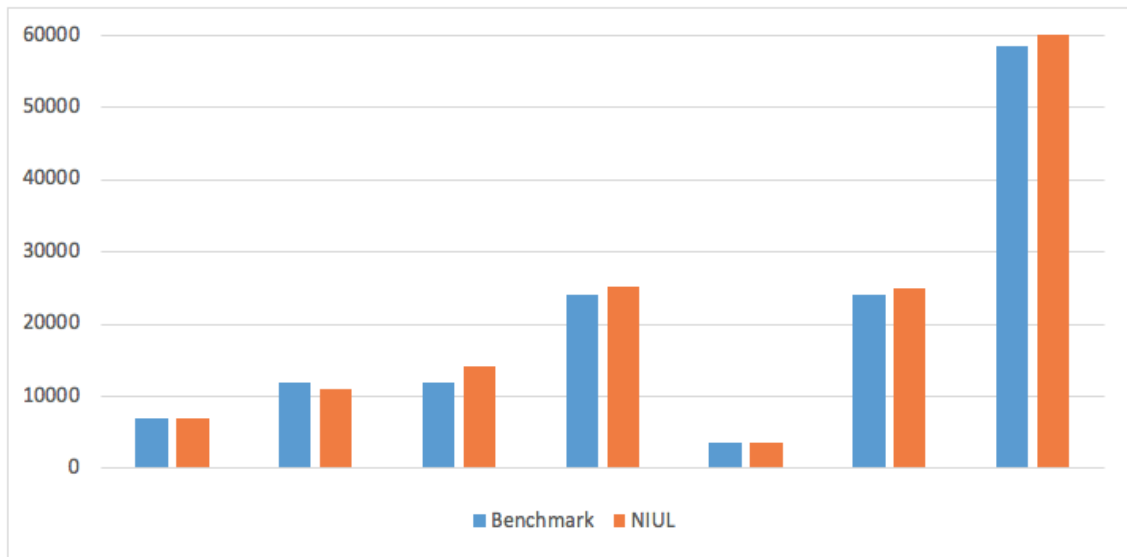

Figure 7.3: Economic measures: benchmark vs NIUL

7.3.2.3 Non-identical firms with limited capacity scenario (NIL)

Power plants vary in size and production capacity. In this scenario, we study the effects of capacity limits on the power plants. We set Q_{ik} at 300 *MWh*, which is much less than the equilibrium output in the last example. This value is chosen deliberately to capture its effect on the equilibrium. We compare the equilibrium of this scenario with the benchmark case to highlight how both capacity limit and different efficiency together impact the economic measures and compare it with the NIUL scenario to highlight the effect of the capacity limit only.

We found that when a firm exhausts its most efficient power plant, it starts operating the next efficient power plant until it reaches the equilibrium point. In this example, the power suppliers use PP_{11} , PP_{13} , PP_{21} and PP_{23} at the maximum capacity and use PP_{12} , PP_{22} for the remaining. Since PP_{12} is more efficient than PP_{22} , it produces more output. This makes the total output of PS_1 higher than PS_2 . This is because the least efficient unit of the first power supplier is more efficient than the least efficient unit of the second power supplier.

Table 7.4: Outputs of power plants in NIL scenario

PP_{11}	PP_{12}	PP_{13}	PS_1	PP_{21}	PP_{22}	PP_{23}	PS_2
300	179	300	779	300	83	300	683

NIL vs benchmark

In this section, we compare the economic measures with those of the benchmark scenario. Even though the overall weighted efficiency of power plants is almost equal to the efficiency in the benchmark scenario, the total output of the power market decreased by 5.6%. Al-

though the producer surplus increased by 5% due to the price increase, the consumer surplus decreased by around 11%. Thus, social welfare decreased by nearly 2.4%, as shown in Figure 4.

NIL vs NIUL

When this scenario is compared with NIUL, the analysis shows interesting results. The competitive advantage PS_2 had in NIUL is lost due to the capacity limit of the most efficient power plants. Since the least efficient power plant of PS_1 is more efficient than PS_2 , the competitive advantage is shifted to PS_1 in this scenario. Although the producer surplus marginally increased by 0.2%, the profit of PS_1 increased by 15.5% and the profit of PS_2 decreased by 11.7%. The consumers in this scenario are worse off by 14.6% due to the loss of 7.6% of power quantity. Due to the great loss of consumer surplus, social welfare lost about 6%.

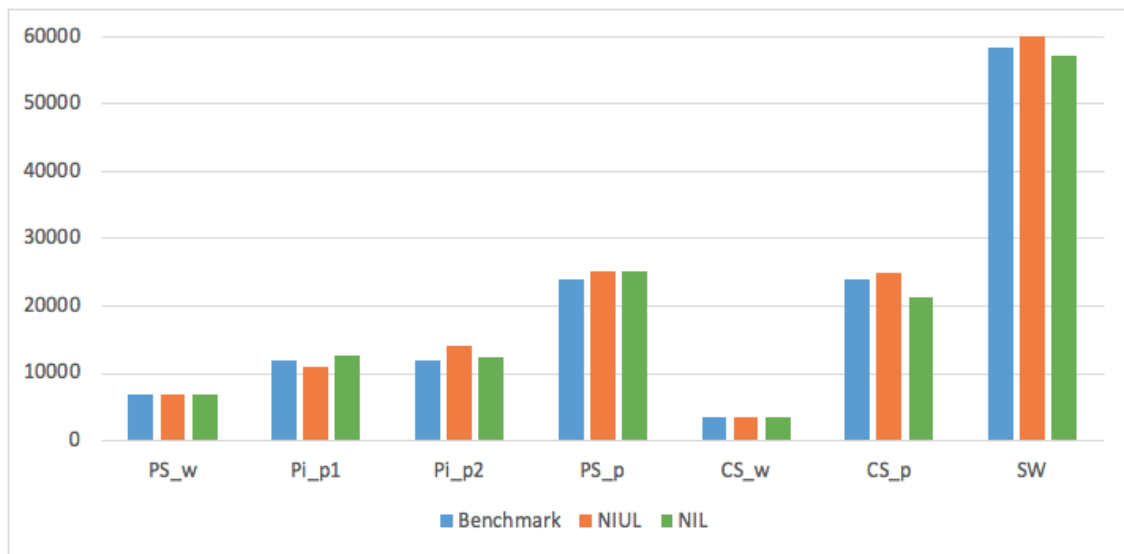

Figure 7.4: Economic measures: benchmark vs NIUL vs NIL

Effect of capacity limit

We illustrate the effect of the capacity limit on the market price in Figure 5. The figure shows the initial equilibrium at the intersection of the uncapacitated supply curve (dashed curve) and the demand curve. When supply is capacitated, the part of the supply curve shifts upward due to the use of a less efficient power plant. The new supply curve intersects with the demand curve at a higher price and lower quantity, causing an increase of the market price and the producer surplus.

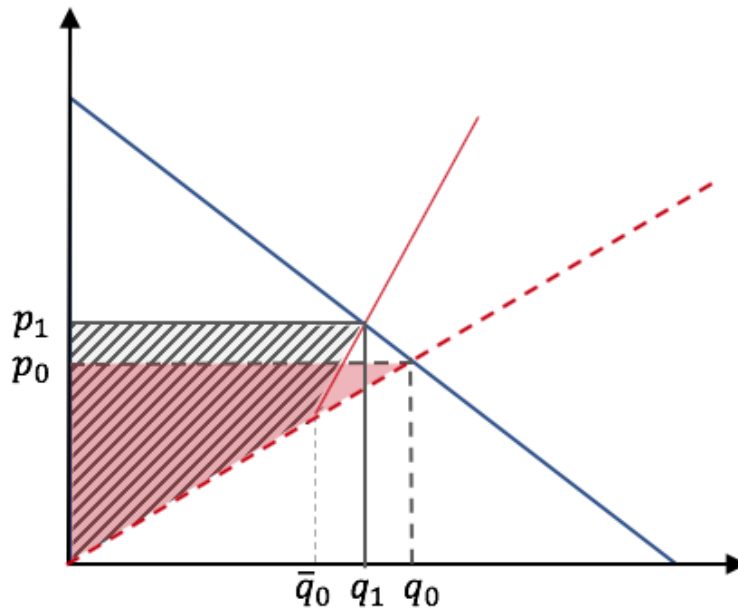

Figure 7.5: Supply curve shift

7.3.2.4 Water-independent firms with limited capacity scenario (WIL)

An ideal scenario is to replace all water-dependent power plants with water-independent power plants. All renewable energy sources, except for hydro-power, are almost water-independent. Wind turbines and solar panels use negligible amounts of water. However, with

the current state of technology, this scenario might be far-fetched. According to OECD, it is projected that renewable energy sources will account for around 10% of all energy generated in 2050. In this scenario, we assume that all firms replaced their traditional power plants with water-independent power plants with the same capacities of the previous scenario, 300 MWh. Although this scenario may not seem realistic in the foreseeable future, it gives an insight of the optimal equilibrium when the water efficiency is at its best. Similar to the benchmark scenario, the power suppliers use any power plants up to the capacity limit. Since the demand of water by power plants is negligible, all water generated is consumed by the end-consumers of water. When a power plant becomes water-independent, the water-energy nexus weakens. Being water-independent helps the power supplier to eliminate a major cost, which leads to a production increase. All economic measures improve by weakening the water-energy nexus. The power suppliers, producer surplus and consumer surplus of power increase by 16% and social welfare increases by 13%.

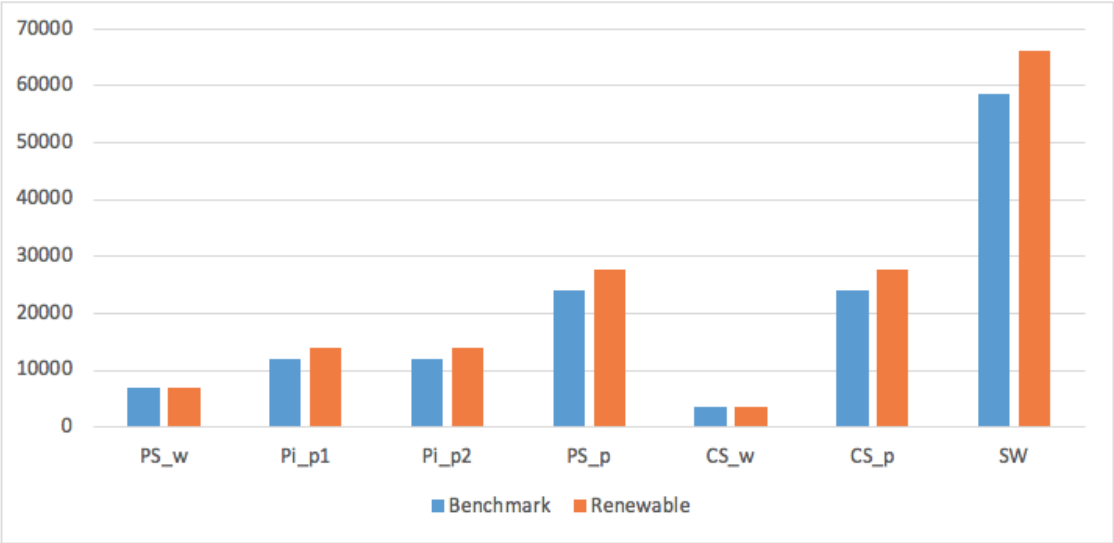

Figure 7.6: Economic measures: benchmark vs WIL

CHAPTER 8:

CONCLUSION AND FUTURE RESEARCH

8.1 Conclusion

The rapid development of technology and population growth places a lot of pressure on governments to tackle the scarcity issue of natural resources such as water and energy. Water and energy are two of the main drivers of humanity and economy. In recent years, it became apparent that these two resources are interconnected. Hence, the water-energy nexus concept was born. However, the interactions of firms in a supply chain in a water-energy nexus have not been investigated. In this research, we approach the water-energy nexus problem as a game between the firms of the water and power industries. Each firm in the supply chain decides the quantity to produce using the commodity of the cross industry as a production input (i.e., water for energy and energy for water) with the objective of maximizing their own profits.

Four different market structures (i.e., models) are introduced in this research. The first model considers a monopoly power market and a monopoly water market. In this mode, we find the Nash equilibrium and analyse various economic measures. We also investigate the effect of technology efficiency on the same market as well as on the cross market. In the second model, we consider a duopoly with identical firms in the water market. The purpose of this model is to investigate the effect of market competition on the market equilibrium and other economic measures. The third model generalizes the second model by considering oligopoly markets with identical firms. Another assumption of the above models besides the

firms being identical is that the firms do not have capacity limits. In the last model, we relax these assumptions. We also consider that power suppliers may own more than one power plant. A case study is considered with different scenarios to apply the last model on and to investigate the effect of technology efficiency and capacity limit.

In the first three models, we solve the problem analytically, find closed-form solutions of the market equilibrium, and study the effect of technology advancement and competition increase on the outputs, profits, consumer and producer surpluses and social welfare. We find that in these market structures, the suppliers of both commodities would either sell to all customers including the suppliers of the cross-industry (i.e., normal case) or sell only to the suppliers of the cross-industry under specific market conditions. In the former case, improving the technology of any firm and increasing competition in any industry increase the outputs of all firms, the producer surplus and the social welfare. In the latter case, however, improving technology and increasing competition do not always lead to better outputs and better economic measures. If the marginal revenue curve of a firm cuts its marginal cost from above, the outputs of both firms, the producer surplus and the social welfare increase; otherwise, they decrease.

We also find that depending on the conditions of the markets, there could be a unique Nash equilibrium or multiple Nash equilibria for the decisions of the firms in the supply chain to make. In the case of multiple Nash equilibria, the research determined the Pareto optimal cases, in which all firms are better off, and the consumer and producer surpluses and social welfare are optimum. In this case, the firms could make vertical coordination to achieve the equilibrium to capture more profits.

In the fourth model, we formulate the problem as a mixed complementarity problem and

solve it with the NLPEC solver in GAMS. Any solution satisfies the MCP conditions is a Nash equilibrium. To validate the model, we consider a case study of the PJM power market. In PJM, 2% of the power sellers sold about 25% of the total power in the first seven months of 2019, which indicates that market power is exercised. We develop a numerical example with two major power suppliers that each own three power plants, and one water supplier. We study different scenarios to highlight the major findings of the model. The benchmark scenario assumes identical uncapacitated firms in the power market. In the second scenario, we assume power plants have different efficiency factors, but still have unlimited production capacity. In the third scenario, we relax the limited capacity assumption. In the last scenario, we assume an ideal case with water-independent power plants.

We find that there are multiple Nash equilibria in all scenarios. The firms may not produce anything leading to loss of profits, surpluses and social welfare, or produce positive outputs generating profits leading to a better surpluses and improved social welfare. The second equilibrium is Pareto optimal since producers and consumers are both better off. This case is guaranteed only if coordination between the two industries is allowed. A government can provide incentives so that the firms can choose a Pareto optimal decision for the benefit of all entities involved.

We also find that when power plants have no capacity limits, they only use their most efficient power plants. A power supplier may have a competitive advantage if its most efficient power plant is more efficient than that of its rival. However, capacity limits may shift this market power to the firm with the most efficient underutilized power plant. We also observe that capacity limits on efficient power plants increase the average cost of production, causing a market price increase. Although the suppliers earn more profits, social welfare is worse due

to a decrease of the consumer surplus.

8.2 Future Research

Water, energy and food are crucial resources in our daily lives and will continue to be. Therefore, understanding the behaviour of the firms in these industries and their interactions is also crucial in determining appropriate policies. This research is intended to establish a base for game-theoretic modeling of the water-energy nexus in particular and the water-energy-food nexus in general. The models in this research do not exploit all the features and elements of the actual markets. Thus, we highlight some of the possible research directions in the following:

- The food industry can be included, to have more understanding of the interactions between the firms in the water, energy and food industries. Research in the energy-food nexus in the biofuel supply chain is established [64–66].
- As there are price maker firms that influence market price, there are price-taker firms that represent the majority of the power market. Including price-taker firms in the models increase its accuracy as their collective production is significant.
- Considering other variables such as transmission constraints and costs, nodal pricing, the cost of importing water or power from other markets in a nexus is also important.

REFERENCES

- [1] Organisation for Economic Co-operation and Development (OECD). OECD Environmental Outlook to 2050. Technical report, OECD Publishing, 2012. URL <http://dx.doi.org/10.1787/9789264122246-en>.
- [2] Intergovernmental Panel on Climate Change (IPCC). Climate Change 2014 Synthesis Report. Contribution of Working Groups I, II and III to the Fifth Assessment Report of the Intergovernmental Panel on Climate Change [Core Writing Team, R.K. Pachauri and L.A. Meyer (eds.)]. Technical report, Geneva, Switzerland, 2014. URL http://www.ipcc.ch/pdf/assessment-report/ar5/syr/SYR_AR5_FINAL_full_wcover.pdf.
- [3] International Energy Agency (IEA). Water for Energy. *World Energy Outlook 2012*, 2012.
- [4] U.S. Environmental Protection Agency (EPA). The Importance of Water to the U.S. Economy. Technical report, United States Environmental Protection Agency, 2013.
- [5] Al Fry. Facts and Trends: Water, 2006. ISSN 0379-7724.
- [6] Jordan Macknick, Robin Newmark, Garvin Heath, and KC Hallett. Operational water consumption and withdrawal factors for electricity generating technologies: a review of existing literature. *Environmental Research Letters*, 7(4):045802, 2012. doi: 10.1088/1748-9326/7/4/045802. URL <http://iopscience.iop.org/lib-ezproxy.tamu.edu:2048/1748-9326/7/4/045802/article/>.
- [7] U.S. Department of Homeland Security. Energy Sector. URL <https://www.dhs.gov/energy-sector>.

- [8] J Macknick, S Sattler, K Averyt, S Clemmer, and J Rogers. The water implications of generating electricity: water use across the United States based on different electricity pathways through 2050. *Environmental Research Letters*, 7(4):045803, 2012. ISSN 1748-9326. doi: 10.1088/1748-9326/7/4/045803. URL <http://iopscience.iop.org/1748-9326/7/4/045803/article/>.
- [9] U.S. Geological Survey (USGS). Saline Water and Salinity. URL <http://water.usgs.gov/edu/saline.html>.
- [10] Kristen Averyt, Jeremy Fisher, Annette Huber-Lee, Aurana Lewis, Jordan Macknick, Nadia Madden, John Rogers, and Stacy Tellinghuisen. Freshwater Use by U.S. Power Plants: Electricity’s Thirst for a Precious Resource. Technical report, 2011.
- [11] Christopher B Harto, Molly Finster, Jenna Schroeder, and Corrie Clark. Saline Water for Power Plant Cooling : Challenges and Opportunities. Technical report, Argonne National Laboratory, 2014.
- [12] J.A. Veil. Use of Reclaimed Water for Power Plant Cooling. Technical report, Argonne National Laboratory, 2007.
- [13] Ashlynn S. Stillwell and Michael E. Webber. Geographic, Technologic, And Economic Analysis of Using Reclaimed Water for Thermoelectric Power Plant Cooling. *Environmental Science & Technology*, 48(8):4588–4595, 4 2014. ISSN 0013-936X. doi: 10.1021/es405820j. URL <http://pubs.acs.org/doi/abs/10.1021/es405820j>.
- [14] Kelly T Sanders. Critical Review: Uncharted Waters? The Future of the Electricity-Water Nexus. *American Chemical Society*, 49(1):51–66, 2015.

- [15] Michael E. Walker, Ranjani B. Theregowda, Iman Safari, Javad Abbasian, Hamid Arastoopour, David A. Dzombak, Ming-Kai Hsieh, and David C. Miller. Utilization of municipal wastewater for cooling in thermoelectric power plants: Evaluation of the combined cost of makeup water treatment and increased condenser fouling. *Energy*, 60:139–147, 10 2013. ISSN 03605442. doi: 10.1016/j.energy.2013.07.066. URL <http://linkinghub.elsevier.com/retrieve/pii/S0360544213006725>.
- [16] Julia Pyper. Can New Waste Treatment Make Energy and Profits from Sewage Plants?, 2011. URL <https://www.scientificamerican.com/article/can-new-waste-treatment-make-energy-profits-sewage-plants/>.
- [17] East Bay Municipal Utility District (EBMUD). Recycling water and energy. URL <http://www.ebmud.com/wastewater/recycling-water-and-energy/>.
- [18] Madsewer. Sustainability. URL <http://www.madsewer.org/Planning/Sustainability>.
- [19] U.S. Government Accountability Office (GAO). Energy-Water Nexus: Improvements to Federal Water Use Data Would Increase Understanding of Trends in Power Plant Water Use. Technical Report October, 2009. URL <http://www.gao.gov/products/GAO-10-23>.
- [20] Daniel Murrant, Andrew Quinn, and Lee Chapman. The water-energy nexus: Future water resource availability and its implications on UK thermal power generation. *Water and Environment Journal*, 29(3):307–319, 9 2015. ISSN 17476593. doi: 10.1111/wej.12126. URL <http://doi.wiley.com/10.1111/wej.12126>.
- [21] Ashlynn S. Stillwell. Sustainability of Public Policy: Example from the Energy–Water Nexus. *Journal of Water Resources Planning and Management*, 141(12), 2015. ISSN 07339496. doi: 10.1061/(ASCE)WR.1943-5452.0000522.

- [22] Frank Ackerman and Jeremy Fisher. Is there a water-energy nexus in electricity generation? Long-term scenarios for the western United States. *Energy Policy*, 59:235–241, 8 2013. ISSN 03014215. doi: 10.1016/j.enpol.2013.03.027. URL <http://www.sciencedirect.com/science/article/pii/S030142151300181X>.
- [23] Lu Liu, Mohamad Hejazi, Pralit Patel, Page Kyle, Evan Davies, Yuyu Zhou, Leon Clarke, and James Edmonds. Water demands for electricity generation in the U.S.: Modeling different scenarios for the water-energy nexus. *Technological Forecasting and Social Change*, 94:318–334, 5 2015. ISSN 00401625. doi: 10.1016/j.techfore.2014.11.004. URL <http://linkinghub.elsevier.com/retrieve/pii/S0040162514003072>.
- [24] Mateus Ricardo Nogueira Vilanova and José Antônio Perrella Balestieri. Exploring the water-energy nexus in Brazil: The electricity use for water supply. *Energy*, 85:415–432, 2015. ISSN 03605442. doi: 10.1016/j.energy.2015.03.083. URL https://ac.els-cdn.com/S0360544215003928/1-s2.0-S0360544215003928-main.pdf?_tid=bc7013cc-aec9-11e7-b201-00000aacb35d&acdnat=1507756893_23cb73bb0419e736872561961e7bdcf4.
- [25] Bart Schoonbaert. *The water-energy nexus in the UK : Assessing the impact of UK energy policy on future water use in thermoelectric power generation*. PhD thesis, Kings College, University of London, 2012. URL <https://www.kcl.ac.uk/sspp/departments/geography/study/masters/dissertations/Dissertation-2012-Schoonbaert.pdf>.
- [26] The Great Lakes Commission. Integrating Energy and Water Resources Decision Making in the Great Lakes Basin: An Examination of Future Power Generation Scenarios and Water Resource Impacts. Technical Report October, 2011. URL <http://glpf.org/wp/wp-content/uploads/2011/03/922-GLEW-Phase-I-Report-FINAL.pdf>.

- [27] Tyler A. DeNooyer, Joshua M. Peschel, Zhenxing Zhang, and Ashlynn S. Stillwell. Integrating water resources and power generation: The energy–water nexus in Illinois. *Applied Energy*, 162:363–371, 2016. ISSN 03062619. doi: 10.1016/j.apenergy.2015.10.071.
- [28] Yuan Chang, Guijun Li, Yuan Yao, Lixiao Zhang, and Chang Yu. Quantifying the water-energy-food nexus: Current status and trends. *Energies*, 9(2):1–17, 2016. ISSN 19961073. doi: 10.3390/en9020065.
- [29] Xin Li, Kuishuang Feng, Yim Ling Siu, and Klaus Hubacek. Energy-water nexus of wind power in China: The balancing act between CO₂ emissions and water consumption. *Energy Policy*, 45:440–448, 6 2012. ISSN 03014215. doi: 10.1016/j.enpol.2012.02.054. URL <http://www.sciencedirect.com/science/article/pii/S0301421512001711>.
- [30] Kuishuang Feng, Klaus Hubacek, Yim Ling Siu, and Xin Li. The energy and water nexus in Chinese electricity production: A hybrid life cycle analysis. *Renewable and Sustainable Energy Reviews*, 39:342–355, 11 2014. ISSN 13640321. doi: 10.1016/j.rser.2014.07.080. URL <http://www.sciencedirect.com/science/article/pii/S1364032114005322>.
- [31] Jin Yang and Bin Chen. Energy-water nexus of wind power generation systems. *Applied Energy*, 169:1–13, 2016. ISSN 03062619. doi: 10.1016/j.apenergy.2016.02.010. URL https://ac.els-cdn.com/S0306261916301337/1-s2.0-S0306261916301337-main.pdf?_tid=200c4f3a-b033-11e7-b351-00000aacb35e&acdnat=1507912108_52fe535f69f6e77635a4dd94ea552479.
- [32] Kaufui V. Wong and James Johnston. Cooling Systems for Power Plants in an Energy-Water Nexus Era. *Journal of Energy Resources Technology*, 136(1):012001, 2013. ISSN

- 0195-0738. doi: 10.1115/1.4024918. URL <http://energyresources.asmedigitalcollection.asme.org/article.aspx?doi=10.1115/1.4024918>.
- [33] Mary E. Clayton, Ashlynn S. Stillwell, and Michael E. Webber. Implementation of brackish groundwater desalination using wind-generated electricity: A case study of the energy-water nexus in Texas. *Sustainability (Switzerland)*, 6(2):758–778, 2 2014. ISSN 20711050. doi: 10.3390/su6020758. URL <http://www.mdpi.com/2071-1050/6/2/758/>.
- [34] Zachary A. Barker and Ashlynn S. Stillwell. Implications of Transitioning from de Facto to Engineered Water Reuse for Power Plant Cooling. *Environmental Science and Technology*, 50(10):5379–5388, 5 2016. ISSN 15205851. doi: 10.1021/acs.est.5b05753. URL <http://pubs.acs.org/doi/abs/10.1021/acs.est.5b05753>.
- [35] Benjamin K Sovacool and Kelly E Sovacool. Identifying future electricity–water tradeoffs in the United States. *Energy Policy*, 37:2763–2773, 2009. doi: 10.1016/j.enpol.2009.03.012.
- [36] Kerron J. Gabriel, Mahmoud M. El-Halwagi, and Patrick Linke. Optimization across the Water-Energy Nexus for Integrating Heat, Power, and Water for Industrial Processes, Coupled with Hybrid Thermal-Membrane Desalination. *Industrial and Engineering Chemistry Research*, 55(12):3442–3466, 2016. ISSN 15205045. doi: 10.1021/acs.iecr.5b03333. URL <http://pubs.acs.org.ezproxy.lib.uwm.edu/doi/pdf/10.1021/acs.iecr.5b03333>.
- [37] Mariano Martín and Ignacio E. Grossmann. Water-energy nexus in biofuels production and renewable based power. *Sustainable Production and Consumption*, 2(February): 96–108, 2015. ISSN 23525509. doi: 10.1016/j.spc.2015.06.005. URL <http://dx.doi.org/10.1016/j.spc.2015.06.005>.

- [38] Gary Gold and Michael Webber. The Energy-Water Nexus: An Analysis and Comparison of Various Configurations Integrating Desalination with Renewable Power. *Resources*, 4(2):227–276, 4 2015. ISSN 2079-9276. doi: 10.3390/resources4020227. URL <http://www.mdpi.com/2079-9276/4/2/227/>.
- [39] Apoorva Santhosh, Amro M. Farid, and Kamal Youcef-Toumi. The impact of storage facility capacity and ramping capabilities on the supply side economic dispatch of the energy-water nexus. *Energy*, 66:363–377, 2014. ISSN 03605442. doi: 10.1016/j.energy.2014.01.031.
- [40] Xiaodong Zhang and Velimir V Vesselinov. Energy-water nexus: Balancing the tradeoffs between two-level decision makers. *Applied Energy*, 183:77–87, 2016. ISSN 0306-2619. doi: 10.1016/j.apenergy.2016.08.156. URL <http://dx.doi.org/10.1016/j.apenergy.2016.08.156>.
- [41] Andreu Mas-Colell, Michael Whinston, D., and Jerry R. Green. *Microeconomic Theory*. page 1008, 1995.
- [42] Li He, Yizhong Chen, Honghai Zhao, Peipei Tian, Yuxuan Xue, and Liang Chen. Game-based analysis of energy-water nexus for identifying environmental impacts during Shale gas operations under stochastic input. *Science of the Total Environment*, 627:1585–1601, 2018. ISSN 18791026. doi: 10.1016/j.scitotenv.2018.02.004.
- [43] Anik Bhaduri and Jens Liebe. Cooperation in Transboundary Water Sharing with Issue Linkage: Game-Theoretical Case Study in the Volta Basin. *Journal of Water Resources Planning and Management*, 139(3):235–245, 2013. ISSN 0733-9496. doi: 10.1061/(ASCE)WR.1943-5452.0000252. URL <http://ascelibrary.org/doi/10.1061/%28ASCE%29WR.1943-5452.0000252>.

- [44] Kaveh Madani. Hydropower licensing and climate change: Insights from cooperative game theory. *Advances in Water Resources*, 34(2):174–183, 2011. ISSN 03091708. doi: 10.1016/j.advwatres.2010.10.003. URL <http://dx.doi.org/10.1016/j.advwatres.2010.10.003>.
- [45] Vishnuteja Nanduri and Wilkistar Otieno. A New Water and Carbon Conscious Electricity Market Model for the Electricity-Water-Climate Change Nexus. *Electricity Journal*, 24(9):64–74, 2011. ISSN 10406190. doi: 10.1016/j.tej.2011.09.021.
- [46] Vishnu Nanduri and Ivan Saavedra-Antolínez. A competitive Markov decision process model for the energy–water–climate change nexus. *Applied Energy*, 111:186–198, 11 2013. ISSN 03062619. doi: 10.1016/j.apenergy.2013.04.033. URL <http://www.sciencedirect.com/science/article/pii/S0306261913003280>.
- [47] U.S. Energy Information Administration (EIA). Today in Energy, 2011. URL <https://www.eia.gov/todayinenergy/detail.php?id=790>.
- [48] M. Pulido-Velazquez, E. Alvarez-Mendiola, and J. Andreu. Design of Efficient Water Pricing Policies Integrating Basinwide Resource Opportunity Costs. *Journal of Water Resources Planning and Management*, 139(5):583–592, 2012. ISSN 0733-9496. doi: 10.1061/(asce)wr.1943-5452.0000262.
- [49] Robin Kundis Craig. Adapting Water Federalism To Climate Change Impacts: Energy Policy, Food Security, and the Allocation of Water Resources. *Environment & Energy Law & Policy Journal*, 5(February):183–236, 2010. URL <http://ssrn.com/abstract=1555944>.

- [50] Murray–Darling Basin Authority. Water markets in the Murray – Darling Basin. Technical Report July, Australian Government, 2015.
- [51] Axel Dreves, Francisco Facchine, Christian Kanzow, and Simone Sagratella. On the solution of the KKT conditions of generalized Nash equilibrium problems. *SIAM Journal on Optimization*, 21(3):1082–1108, 2011. ISSN 10526234. doi: 10.1137/100817000. URL <http://www.siam.org/journals/ojsa.php>.
- [52] Jeffrey Church and Roger Ware. *Industrial Organization : A Strategic Approach*, volume 12. McGraw-Hill, New York City, NY, 2000. ISBN 025620571X. URL http://works.bepress.com/jeffrey_church/23/.
- [53] Steven M. LaValle. *Planning Algorithms*. Cambridge University Press, Cambridge, 2006. ISBN 9780511546877. doi: 10.1017/CBO9780511546877. URL <http://planning.cs.uiuc.edu/node461.html><https://www.cambridge.org/core/product/identifier/9780511546877/type/book>.
- [54] H. Chen, K.P. Wong, D.H.M Nguyen, and C.Y. Chung. Analyzing oligopolistic electricity market using coevolutionary computation. *IEEE Transactions on Power Systems*, 21(1):143–152, 2006. doi: 10.1109/TPWRS.2005.862005.
- [55] Benjamin F. Hobbs. Linear complementarity models of nash-Cournot competition in bilateral and POOLCO power markets. *IEEE Transactions on Power Systems*, 16(2):194–202, 2001. doi: 10.1109/59.918286.
- [56] A.S. Chuang, F. Wu, and P. Varaiya. A game-theoretic model for generation expansion planning: problem formulation and numerical comparisons. *IEEE Transactions on*

- Power Systems*, 16(4):885–891, 2001. ISSN 08858950. doi: 10.1109/59.962441. URL <http://ieeexplore.ieee.org/document/962441/>.
- [57] Stephen Merret. *Introduction to the Economics of Water Resources*. 1997. ISBN 0203645391. doi: 10.1017/CBO9781107415324.004.
- [58] Andrew C. Worthington. Commercial and industrial water demand estimation: Theoretical and methodological guidelines for applied economics research. *Estudios de Economía Aplicada*, 28(2):237–258, 2010. doi: ISSN1697-5731. URL <http://www.redalyc.org/html/301/30120357002/>.
- [59] Michael C Ferris and Todd S Munson. Complementarity Problems in GAMS and the PATH Solver. 1998. URL <http://pages.cs.wisc.edu/~ferris/techreports/98-12.pdf>.
- [60] Nabeel Hamoud and Jaejin Jang. The Effect of Technology Efficiency and Market Competition on a Closed-Loop Water-Energy Nexus. *International Journal of Energy Research*, page under review, 2019.
- [61] PJM. PJM Manual 11 :Services, Ancillary Operations, Market Operations, Real-time Market. Technical report, 2019. URL <https://www.pjm.com/~media/documents/manuals/m11.ashx>.
- [62] Ronald C. Griffin. *Water Resource Economics: The Analysis of Scarcity Policies and Projects*. The MIT Press, Cambridge, Mass, 12 2006. ISBN 026207267X.
- [63] R. Goldstein and W. Smith. Water & Sustainability: U.S. Electricity Consumption for Water Supply & Treatment - The Next Half Century. Technical Report Volume 4, 2002. URL <http://www.circleofblue.org/wp-content/uploads/2010/08/EPRI-Volume-4.pdf>.

- [64] Amirsaman H. Bajgiran, Jaejin Jang, Xiang Fang, and James H. Peoples. A biofuel supply chain equilibrium analysis with subsidy consideration. *International Journal of Energy Research*, 43(5):1848–1867, 2019. ISSN 1099114X. doi: 10.1002/er.4422.
- [65] Yun Bai, Yanfeng Ouyang, and Jong Shi Pang. Biofuel supply chain design under competitive agricultural land use and feedstock market equilibrium. *Energy Economics*, 34(5):1623–1633, 2012. ISSN 01409883. doi: 10.1016/j.eneco.2012.01.003. URL <http://dx.doi.org/10.1016/j.eneco.2012.01.003>.
- [66] Xiaolei Wang, Yanfeng Ouyang, Hai Yang, and Yun Bai. Optimal biofuel supply chain design under consumption mandates with renewable identification numbers. *Transportation Research Part B: Methodological*, 57:158–171, 11 2013. ISSN 01912615. doi: 10.1016/j.trb.2013.07.008. URL <http://linkinghub.elsevier.com/retrieve/pii/S0191261513001239>.

APPENDIX A:

WATER USAGE OF NON-RENEWABLE POWER PRODUCTION TECHNOLOGIES

Table A.1: Water consumption factors for non-renewable technologies (gal/MWh)

Fuel Type	Cooling	Technology	Median	Min	Max
Nuclear	Tower	Generic	672	581	845
	Once-through	Generic	269	100	400
	Pond	Generic	610	560	720
Natural Gas	Tower	Combined Cycle	198	130	300
		Steam	826	662	1,170
		Combined Cycle with CCS	378	378	378
	Once-through	Combined Cycle	100	20	100
		Steam	240	95	291
	pond	Combined Cycle	240	240	240
	Dry	Combined Cycle	2	0	4
	Inlet	Steam	340	80	600
Coal	Tower	Generic	687	480	1,100
		Subcritical	471	394	664
		Supercritical	493	458	594
		IGCC	372	318	439
		Subcritical with CCS	942	942	942

continued on next page

continued from previous page

		Supercritical with CCS	846	846	846
		IGCC with CCS	540	522	558
	Once-through	Generic	250	100	317
		Subcritical	113	71	138
		Supercritical	103	64	124
	Pond	Generic	545	300	700
		Subcritical	779	737	804
		Supercritical	42	4	64

Table A.2: Water withdrawal factors for non-renewable technologies (gal/MWh)

Fuel Type	Cooling	Technology	Median	Min	Max
Nuclear	Tower	Generic	1,101	800	2,600
	Once-through	Generic	44,350	25,000	60,000
	Pond	Generic	7,050	500	13,000
Natural Gas	Tower	Combined Cycle	253	150	283
		Steam	1,203	950	1,460
		Combined Cycle with CCS	496	487	506
	Once-through	Combined Cycle	11,380	7,500	20,000
		Steam	35,000	10,000	60,000
	Pond	Combined Cycle	5,950	5,950	5,950
	Dry	Combined Cycle	2	0	4
	Inlet	Steam	425	100	750
Coal	Tower	Generic	1,005	500	1,200
		Subcritical	531	463	678
		Supercritical	609	582	669
		IGCC	390	358	605
		Subcritical with CCS	1,277	1,224	1,329
		Supercritical with CCS	1,123	1,098	1,148
		IGCC with CCS	586	479	678
	Once-through	Generic	36,350	20,000	50,000
		Subcritical	27,088	27,046	27,113
		Supercritical	22,590	22,551	22,611

continued on next page

continued from previous page

	Pond	Generic	12,225	300	24,000
		Subcritical	17,914	17,859	17,927
		Supercritical	15,046	14,996	15,057
Biopower	Tower	Steam	878	500	1,460
	Once-through	Steam	35,000	20,000	50,000
	Pond	Steam	450	300	600

APPENDIX B:

ANALYSIS OF MODEL I

Appendices B1-B3 provide proofs of three of the possible equilibria of Model I. As discussed in the text, only these equilibria result in positive outputs and profits. Appendix B.4 summarizes related economic measures of the equilibria. Appendix B.5 proves that the profits, consumer surplus, producer surplus and social welfare in case I-1 is higher than in the other cases when there are multiple equilibria. The KKT conditions of this model shown in sec. 4.1.1 can be rewritten as follows:

$$A - 2Bq - (a - bw) \psi - \psi \lambda_1 \leq 0 \quad (\text{B.1})$$

$$a - 2bw - (A - Bq) \epsilon - \epsilon \lambda_2 \leq 0 \quad (\text{B.2})$$

$$\psi q - w \leq 0 \quad (\text{B.3})$$

$$\epsilon w - q \leq 0 \quad (\text{B.4})$$

$$(A - 2Bq - (a - bw) \psi - \psi \lambda_1) q = 0 \quad (\text{B.5})$$

$$(a - 2bw - (A - Bq) \epsilon - \epsilon \lambda_2) w = 0 \quad (\text{B.6})$$

$$(\psi q - w) \lambda_1 = 0 \quad (\text{B.7})$$

$$(\epsilon w - q) \lambda_2 = 0 \quad (\text{B.8})$$

$$q \geq 0 \quad (\text{B.9})$$

$$w \geq 0 \quad (\text{B.10})$$

$$\lambda_1 \geq 0 \quad (\text{B.11})$$

$$\lambda_2 \geq 0 \quad (\text{B.12})$$

B.1 Proof of the equilibrium of case I-1

In this case, it is assumed that $\lambda_1 = \lambda_2 = 0$

From (B.3),

$$\epsilon\psi w \leq \psi q \tag{B.1.1}$$

From (B.4),

$$\psi q \leq w \tag{B.1.2}$$

From (B.1.1) and (B.1.2),

$$\epsilon\psi w \leq \psi q \leq w \tag{B.1.3}$$

From (B.1.3)

$$\epsilon\psi \leq 1 \tag{B.1.4}$$

From (B.5), the best response of the power supplier:

$$q^{BR} = \frac{(A - \psi(a - bw))}{2B} \tag{B.1.5}$$

From (B.6), the best response of the water supplier:

$$w^{BR} = \frac{(a - \epsilon(A - Bq))}{2b} \tag{B.1.6}$$

Solving (B.1.5) and (B.1.6), we find the equilibrium outputs of the power and water suppliers, respectively:

$$q = \frac{(2 - \epsilon\psi)A - a\psi}{(4 - \epsilon\psi)B} \tag{B.1.7}$$

$$w = \frac{(2 - \epsilon\psi)a - A\epsilon}{(4 - \epsilon\psi)b} \tag{B.1.8}$$

From (B.1.4, B.1.7 and B.1.8), the denominators are positive, thus the numerators should also be positive because q and $w > 0$, which follows,

$$(2 - \epsilon\psi) A - a\psi > 0 \quad (\text{input condition for } q) \quad (\text{B.1.9})$$

$$(2 - \epsilon\psi) a - A\epsilon > 0 \quad (\text{input condition for } w) \quad (\text{B.1.10})$$

From (B.1.9) and (B.1.10),

$$\frac{\psi}{(2 - \epsilon\psi)} < \frac{A}{a} < \frac{(2 - \epsilon\psi)}{\epsilon} \quad (\text{B.1.11})$$

(B.1.11) shows that if $\epsilon\psi = 1$, the RHS = LHS, which is not possible in this case. Thus,

$$\epsilon\psi < 1 \quad (\text{B.1.4}') \quad (\text{B.1.4'})$$

From (B.3, B.1.7 and B.1.8),

$$\epsilon B ((2 - \epsilon\psi) a - A\epsilon) \leq b ((2 - \epsilon\psi) A - a\psi) \quad (\text{B.1.12})$$

From (B.4, B.1.7 and B.1.8),

$$\psi b ((2 - \epsilon\psi) A - a\psi) \leq B ((2 - \epsilon\psi) a - A\epsilon) \quad (\text{B.1.13})$$

From (B.1.12) and (B.1.13),

$$\frac{((2 - \epsilon\psi) \epsilon B + \psi b) \epsilon}{((2 - \epsilon\psi) b + \epsilon^2 B)} \leq \frac{A\epsilon}{a} \leq \frac{((2 - \epsilon\psi) B + \psi^2 b) \epsilon}{((2 - \epsilon\psi) \psi b + \epsilon B)} \quad (\text{B.1.14})$$

We want to check if either (B.1.11) or (B.1.14) is redundant. Let us first compare the RHSs of (B.1.11) and (B.1.14).

We assume (B.1.14) \leq (B.1.11):

$$\frac{((2 - \epsilon\psi) B + \psi^2 b)}{((2 - \epsilon\psi) \psi b + \epsilon B)} \leq \frac{(2 - \epsilon\psi)}{\epsilon}$$

$$5\epsilon\psi \leq 4 + (\epsilon\psi)^2$$

Given (B.1.4'), we know that (B.1.14) is less than or equal to (B.1.11). Now, we compare the LHSs of (B.1.11) and (B.1.14). Let us assume (B.1.11) \leq (B.1.14),

$$\frac{\psi}{(2 - \epsilon\psi)} \leq \frac{((2 - \epsilon\psi) \epsilon B + \psi b)}{((2 - \epsilon\psi) b + \epsilon^2 B)}$$

$$5\epsilon\psi \leq 4 + (\epsilon\psi)^2$$

Given (B.1.4'), this equation always holds, and we know that the LHS of (B.1.14) is greater than or equal to (B.1.11). From the comparisons above, (B.1.14) is a subset of (B.1.11); that is, if (B.1.14) holds, (B.1.11) holds.

Summary of input conditions:

$$\epsilon\psi < 1 \text{ and } \frac{((2 - \epsilon\psi) \epsilon B + \psi b) \epsilon}{((2 - \epsilon\psi) b + \epsilon^2 B)} \leq \frac{A\epsilon}{a} \leq \frac{((2 - \epsilon\psi) B + \psi^2 b) \epsilon}{((2 - \epsilon\psi) \psi b + \epsilon B)}$$

B.2 Proof of the equilibrium of case I-2

In this case, it is assumed that $\lambda_1 > 0$ and $\lambda_2 = 0$

From (B.7),

$$\psi q = w \tag{B.2.1}$$

From (B.4),

$$\epsilon w \leq q \tag{B.2.2}$$

From (B.2.1) and (B.2.2),

$$\epsilon\psi w \leq w \quad (\text{B.2.3})$$

From (B.2.3),

$$\epsilon\psi \leq 1 \quad (\text{B.2.4})$$

From (B.5),

$$q^{BR} = \frac{(A - (a - bw)\psi - \psi\lambda_1)}{2B} \quad (\text{B.2.5})$$

From (B.6),

$$w^{BR} = \frac{a - (A - Bq)\epsilon}{2b} \quad (\text{B.2.6})$$

Solving (B.2.1), (B.2.5) and (B.2.6) for w and q , we find the equilibrium outputs and shadow price:

$$w = -\frac{\psi(a - A\epsilon)}{(B\epsilon - 2b\psi)} \quad (\text{B.2.7})$$

$$q = -\frac{(a - A\epsilon)}{(B\epsilon - 2b\psi)} \quad (\text{B.2.8})$$

$$\lambda_1 = \frac{2Ba - AB\epsilon - 2Ab\psi + ab\psi^2 + Ab\epsilon\psi^2 - Ba\epsilon\psi}{\psi(B\epsilon - 2b\psi)} > 0 \quad (\text{B.2.9})$$

Here we check the input conditions for (B.2.7), (B.2.8) and (B.2.9):

If $\frac{B\epsilon}{b\psi} = 2$, no solution exists.

If $\frac{B\epsilon}{b\psi} > 2$,

from q , $w > 0$,

$$\frac{A\epsilon}{a} > 1 \quad (\text{B.2.10})$$

and from $\lambda_1 > 0$,

$$\frac{A\epsilon}{a} < \frac{((2 - \epsilon\psi) B + b\psi^2) \epsilon}{((2 - \epsilon\psi) b\psi + \epsilon B)} \quad (\text{B.2.11})$$

If $\frac{B\epsilon}{b\psi} < 2$,

from $q, w > 0$,

$$\frac{A\epsilon}{a} < 1 \quad (12) \quad (\text{B.2.12})$$

and from $\lambda_1 > 0$,

$$\frac{A\epsilon}{a} > \frac{((2 - \epsilon\psi) B + b\psi^2) \epsilon}{((2 - \epsilon\psi) b\psi + \epsilon B)} \quad (13) \quad (\text{B.2.13})$$

From (B.2.4), if $\epsilon\psi = 1$, (B.2.10) = (B.2.11) which is not possible; thus,

$$\epsilon\psi < 1 \quad (4')$$

Summary of input conditions:

$$\begin{aligned} \psi\epsilon < 1, \quad \frac{B\epsilon}{b\psi} < 2 \quad \text{and} \quad \frac{((2 - \epsilon\psi) B + \psi^2 b) \epsilon}{((2 - \epsilon\psi) \psi b + \epsilon B)} < \frac{A\epsilon}{a} < 1 \quad (\text{case I-2.A}), \text{ or} \\ \psi\epsilon < 1, \quad \frac{B\epsilon}{b\psi} > 2 \quad \text{and} \quad 1 < \frac{A\epsilon}{a} < \frac{((2 - \epsilon\psi) B + \psi^2 b) \epsilon}{((2 - \epsilon\psi) \psi b + \epsilon B)} \quad (\text{case I-2.B}) \end{aligned}$$

B.3 Proof of the equilibrium of case I-3

From (B.3), In this case, it is assumed that $\lambda_1 = 0$ and $\lambda_2 > 0$

$$\psi q \leq w \quad (\text{B.3.1})$$

From (B.8),

$$\epsilon w = q \quad (\text{B.3.2})$$

From (B.3.1) and (B.3.2),

$$\epsilon\psi q \leq q \quad (\text{B.3.3})$$

From (3),

$$\epsilon\psi \leq 1 \quad (\text{B.3.4})$$

From (B.5),

$$q^{BR} = \frac{(A - (a - bw)\psi)}{2B} \quad (\text{B.3.5})$$

From (B.6),

$$w^{BR} = \frac{a - (A - Bq)\epsilon - \epsilon\lambda_2}{2b} \quad (\text{B.3.6})$$

Solving (B.3.2), (B.3.5) and (B.3.6) for q and w , we find the equilibrium outputs and shadow price:

$$q = \frac{\epsilon(A - a\psi)}{2B\epsilon - b\psi} \quad (\text{B.3.7})$$

$$w = \frac{A - a\psi}{2B\epsilon - b\psi} \quad (\text{B.3.8})$$

$$\lambda_2 = -\frac{2Ab - 2Ba\epsilon - ab\psi + AB\epsilon^2 + Ba\epsilon^2\psi - Ab\epsilon\psi}{\epsilon(2B\epsilon - b\psi)} > 0 \quad (\text{B.3.9})$$

Here we check the input conditions for (B.3.7), (B.3.8) and (B.3.9):

If $\frac{B\epsilon}{b\psi} = \frac{1}{2}$, no solution exists

If $\frac{B\epsilon}{b\psi} > \frac{1}{2}$,

from $q, w > 0$,

$$\frac{A\epsilon}{a} > \epsilon\psi \quad (\text{B.3.10})$$

and from λ_2 ,

$$\frac{A\epsilon}{a} < \frac{((2 - \epsilon\psi) B\epsilon + b\psi) \epsilon}{((2 - \epsilon\psi) b + B\epsilon^2)} \quad (\text{B.3.11})$$

If $\frac{B\epsilon}{b\psi} < \frac{1}{2}$,

from $q, w > 0$,

$$\frac{A\epsilon}{a} < \epsilon\psi \quad (\text{B.3.12})$$

and from λ_2 ,

$$\frac{A\epsilon}{a} > \frac{((2 - \epsilon\psi) B\epsilon + b\psi) \epsilon}{((2 - \epsilon\psi) b + B\epsilon^2)} \quad (\text{B.3.13})$$

From (B.3.4), if $\epsilon\psi = 1$, (B.3.10) = (B.3.11) which is not possible; thus,

$$\epsilon\psi < 1$$

Summary of input conditions:

$$\begin{aligned} \psi\epsilon < 1, \quad \frac{B\epsilon}{b\psi} > \frac{1}{2} \text{ and } \epsilon\psi < \frac{A\epsilon}{a} < \frac{((2 - \epsilon\psi) \epsilon B + \psi b) \epsilon}{((2 - \epsilon\psi) b + \epsilon^2 B)} \quad (\text{case I-3.A}), \text{ or} \\ \psi\epsilon < 1, \quad \frac{B\epsilon}{b\psi} < \frac{1}{2} \text{ and } \frac{((2 - \epsilon\psi) \epsilon B + \psi b) \epsilon}{((2 - \epsilon\psi) b + \epsilon^2 B)} < \frac{A\epsilon}{a} < \epsilon\psi \quad (\text{case I-3.B}) \end{aligned}$$

B.4 Economic measures of Model I

Table B.1: Economic measures of case I-1

Economic Measure		Value
Power Output	q	$\frac{(2 - \epsilon\psi) A - a\psi}{(4 - \epsilon\psi) B}$
Water Output	w	$\frac{(2 - \epsilon\psi) a - A\epsilon}{(4 - \epsilon\psi) b}$
PS Profit	π_P	$\frac{(2A - \epsilon\psi A - a\psi)^2}{B(4 - \epsilon\psi)^2}$
WS Profit	π_W	$\frac{(2a - \epsilon\psi a - A\epsilon)^2}{b(4 - \epsilon\psi)^2}$
Consumer Surplus (Power)	CS_P	$\frac{(a\psi - 2A + A\epsilon\psi)^2}{2B(4 - \epsilon\psi)^2}$
Consumer Surplus (Water)	CS_W	$\frac{(A\epsilon - 2a + a\epsilon\psi)^2}{2b(4 - \epsilon\psi)^2}$
Total Social Welfare	SW	$\frac{3(\pi_{PP} + \pi_{WP})}{2}$

Table B.2: Economic measures of case I-2

Economic Measure		Value
Power Output	q	$\frac{(A\epsilon - a)}{(B\epsilon - 2b\psi)}$
Water Output	w	$\frac{\psi(A\epsilon - a)}{(B\epsilon - 2b\psi)}$
PS Profit	π_P	$\frac{(A\epsilon - a)(Ba(1 - \epsilon\psi) + b\psi(a\psi - A(2 - \epsilon\psi)))}{(B\epsilon - 2b\psi)^2}$
WS Profit	π_W	$\frac{b\psi^2(a - A\epsilon)^2}{(B\epsilon - 2b\psi)^2}$
Consumer Surplus (Power)	CS_P	$\frac{B(a - A\epsilon)^2}{2(B\epsilon - 2b\psi)^2}$
Consumer Surplus (Water)	CS_W	$\frac{b\psi^2(a - A\epsilon)^2}{2(B\epsilon - 2b\psi)^2}$
Total Social Welfare	SW	$\frac{(A\epsilon - a)(B(a + A\epsilon - 2a\epsilon\psi) - b\psi(4A + a\psi - 5A\epsilon\psi))}{2(B\epsilon - 2b\psi)^2}$

Table B.3: Economic measures of case I-3

Economic Measure		Value
Power Output	q	$\frac{A\epsilon - a\epsilon\psi}{2B\epsilon - b\psi}$
Water Output	w	$\frac{A - a\psi}{2B\epsilon - b\psi}$
PS Profit	π_P	$\frac{B\epsilon^2 (A - a\psi)^2}{(2B\epsilon - b\psi)^2}$
WS Profit	π_W	$\frac{(a\psi - A) Ab (1 - \epsilon\psi) + B\epsilon (A\epsilon - a (2 - \epsilon\psi))}{(2B\epsilon - b\psi)^2}$
Consumer Surplus (Power)	CS_P	$\frac{B\epsilon^2 (A - a\psi)^2}{2 (2B\epsilon - b\psi)^2}$
Consumer Surplus (Water)	CS_W	$\frac{b (A - a\psi)^2}{2 (2B\epsilon - b\psi)^2}$
Total Social Welfare	SW	$\frac{(a\psi - A) (b (A + a\psi - 2A\epsilon\psi) - B\epsilon (4a + A\epsilon - 5a\epsilon\psi))}{2 (2B\epsilon - b\psi)^2}$

B.5 Proof of Pareto optimality of case I-1 (multiple equilibria)

As discussed in the text, there are input conditions that have multiple equilibria, as in case I-1 and case I-2.B (or case I-3). In this part, we prove that the equilibrium of case I-1 is pareto optimal (i.e. the profits, consumer surpluses and social welfare in case I-1 are higher than those in case I-2 (or case I-3)).

The profit of the power supplier:

Factoring $\pi_P^{1,1} - \pi_P^{1,2}$, we get the product of the terms (B.5.1) to (B.5.5) given below:

$$AB\epsilon - 2Ba + 2Ab\psi - ab\psi^2 - Ab\epsilon\psi^2 + Ba\epsilon\psi < 0 \quad (\text{B.5.1})$$

$$AB\epsilon^3\psi^2 - Ba\epsilon^2\psi^2 - 4AB\epsilon^2\psi - 4Ab\epsilon\psi^2 + 8Ba\epsilon\psi + 4AB\epsilon - 4ab\psi^2 + 8Ab\psi - 8Ba < 0 \quad (\text{B.5.2})$$

$$1/B > 0 \quad (\text{B.5.3})$$

$$1/(\epsilon\psi - 4)^2 > 0 \quad (\text{B.5.4})$$

$$1/(B\epsilon - 2b\psi)^2 > 0 \quad (\text{B.5.5})$$

Here, (B.5.3), (B.5.4) and (B.5.5) are positive. $\pi_P^{1,1} > \pi_P^{1,2}$ if equations (B.5.1) and (B.5.2) are both positive or both negative.

Proof of (B.5.1):

Setting $AB\epsilon - 2Ba + 2Ab\psi - ab\psi^2 - Ab\epsilon\psi^2 + Ba\epsilon\psi < 0$ and solving for $A\epsilon/a$, we find:

$$\frac{A\epsilon}{a} < \frac{((2 - \epsilon\psi)B + \psi^2b)\epsilon}{((2 - \epsilon\psi)\psi b + \epsilon B)}, \quad (\text{B.5.6})$$

which is always true since (B.5.6) is the input condition of cases I-1 and I-2. \square

Proof of (B.5.2):

Setting $AB\epsilon^3\psi^2 - Ba\epsilon^2\psi^2 - 4AB\epsilon^2\psi - 4Ab\epsilon\psi^2 + 8Ba\epsilon\psi + 4AB\epsilon - 4ab\psi^2 + 8Ab\psi - 8Ba < 0$ and solving for $A\epsilon/a$, we find:

$$\frac{A\epsilon}{a} < \frac{(B\epsilon^2\psi^2 - 8B\epsilon\psi + 4b\psi^2 + 8B)\epsilon}{(B\epsilon^3\psi^2 - 4B\epsilon^2\psi - 4b\epsilon\psi^2 + 4B\epsilon + 8b\psi)} \quad (\text{B.5.7})$$

Given the assumptions that $A\epsilon/a > 1$ and $B\epsilon/b\psi > 2$ (from case I-2.B), we find that (B.5.6) is a subset of (B.5.7). Thus, (B.5.7) always holds. Therefore, $\pi_P^{1,1} > \pi_P^{1,2}$, and by

symmetry $\pi_P^{1,1} > \pi_P^{1,3}$ \square

The profit of the water supplier:

Factoring $\pi_W^{1,1} - \pi_W^{1,2}$, we get the value is a product of the terms (8) to (13) given below:

$$\epsilon > 0 \tag{B.5.8}$$

$$AB\epsilon - 2Ba + 2Ab\psi - ab\psi^2 - Ab\epsilon\psi^2 + Ba\epsilon\psi < 0 \text{ (see proof of (B.5.1))} \tag{B.5.9}$$

$$Ab\epsilon^2\psi^2 + Ba\epsilon^2\psi + AB\epsilon^2 - 3ab\epsilon\psi^2 - 6Ab\epsilon\psi - 2Ba\epsilon + 8ab\psi < 0 \tag{B.5.10}$$

$$1/b > 0 \tag{B.5.11}$$

$$1/(\epsilon\psi - 4)^2 > 0 \tag{B.5.12}$$

$$1/(B\epsilon - 2b\psi)^2 > 0 \tag{B.5.13}$$

Proof of (B.5.10):

Assuming (B.5.10) is negative and solving it for $A\epsilon/a$, we find,

$$\frac{A\epsilon}{a} > \frac{\frac{B\epsilon}{b\psi}(2 - \epsilon\psi) - 8 + 3\epsilon\psi}{\frac{B\epsilon}{b\psi} + \epsilon\psi - 6} \text{ iff } \frac{B\epsilon}{b\psi} < 6 - \epsilon\psi \tag{B.5.14}$$

Examining (B.5.14), we find that if $B\epsilon/b\psi < 6 - \epsilon\psi$, the RHS is less than 1. Given that

$A\epsilon/a > 1$ from the input conditions of case I-2.B, the equation always holds. If $B\epsilon/b\psi > 6 - \epsilon\psi$, (B.5.14) is always greater than $((2 - \epsilon\psi)B + \psi^2b)\epsilon / (((2 - \epsilon\psi)\psi b + \epsilon B))$ (an input condition of case I-2.B). Thus, (B.5.10) is strictly negative and $\pi_W^{1,1} > \pi_W^{1,2}$. By symmetry, $\pi_W^{1,1} > \pi_W^{1,3}$ \square

The consumer surplus of the power industry:

Factoring $CS_P^{1,1} - CS_P^{1,2}$, we get the factors (15) to (20) given below:

$$2 > 0 \tag{B.5.15}$$

$$AB\epsilon^2\psi - Ab\epsilon\psi^2 - 3AB\epsilon - ab\psi^2 + 2Ab\psi + 2Ba < 0 \text{ (see proof below)} \tag{B.5.16}$$

$$AB\epsilon - 2Ba + 2Ab\psi - ab\psi^2 - Ab\epsilon\psi^2 + Ba\epsilon\psi < 0 \text{ (see proof of (B.5.1))} \tag{B.5.17}$$

$$1/B > 0 \tag{B.5.18}$$

$$1/(\epsilon\psi - 4) > 0 \tag{B.5.19}$$

$$1/(B\epsilon - 2b\psi)^2 > 0 \tag{B.5.20}$$

Proof of (B.5.16):

Assuming (B.5.16) is negative and solving it for $A\epsilon/a$, we get:

$$\frac{A\epsilon}{a} > \frac{(2B - b\psi^2)\epsilon}{-B\epsilon^2\psi + b\epsilon\psi^2 + 3B\epsilon - 2b\psi} \tag{B.5.21}$$

Given that $A\epsilon/a > 1$ from the input conditions of case I-2.B, equation (B.5.21) always holds and is negative. Thus, $CS_P^{1,1} > CS_P^{1,2}$ \square

The consumer surplus of the water industry:

Factoring $CS_w^{1,1} - CS_w^{1,2}$, we get the factors (22) to (28) given below:

$$1/2 > 0 \tag{B.5.22}$$

$$\epsilon > 0 \tag{B.5.23}$$

$$AB\epsilon - 2Ba + 2Ab\psi - ab\psi^2 - Ab\epsilon\psi^2 + Ba\epsilon\psi < 0 \text{ (see proof of (B.5.1))} \tag{B.5.24}$$

$$Ab\epsilon^2\psi^2 + Ba\epsilon^2\psi + AB\epsilon^2 - 3ab\epsilon\psi^2 - 6Ab\epsilon\psi - 2Ba\epsilon + 8ab\psi < 0 \text{ (see proof of (B.5.10))} \tag{B.5.25}$$

$$1/b > 0 \tag{B.5.26}$$

$$1/(\epsilon\psi - 4)^2 > 0 \tag{B.5.27}$$

$$1/(B\epsilon - 2b\psi)^2 > 0 \tag{B.5.28}$$

Given the product of equations (B.5.22)-(B.5.28) is positive, $CS_w^{1,1} > CS_w^{1,2}$ \square

B.6 Effect of technology improvement on the economic measures of Model I

This section shows the effect of the improvement of the power and water technologies on various economic measures. We show the results for cases I-1 and I-2.A. for the results for case I-3 is symmetrical to results for case I-2.

Table B.4: Effect of technology improvement on economic measures of case I-1

	Value	Sign
$-\frac{\partial q}{\partial \psi}$	$\frac{4a + 2A\epsilon}{B(\epsilon\psi - 4)^2}$	> 0
$-\frac{\partial q}{\partial \epsilon}$	$\frac{\psi(2A + a\psi)}{B(\epsilon\psi - 4)^2}$	> 0
$-\frac{\partial w}{\partial \psi}$	$\frac{\epsilon(2a + A\epsilon)}{b(\epsilon\psi - 4)^2}$	> 0
$-\frac{\partial w}{\partial \epsilon}$	$\frac{4A + 2a\psi}{b(\epsilon\psi - 4)^2}$	> 0
$-\frac{\partial \pi_P}{\partial \psi}$	$\frac{(8a + 4A\epsilon)(a\psi - 2A + A\epsilon\psi)}{B(\epsilon\psi - 4)^3}$	> 0
$-\frac{\partial \pi_P}{\partial \epsilon}$	$\frac{2\psi(2A + a\psi)(a\psi - 2A + A\epsilon\psi)}{B(\epsilon\psi - 4)^3}$	> 0
$-\frac{\partial \pi_w}{\partial \psi}$	$\frac{2\epsilon(2a + A\epsilon)(A\epsilon - 2a + a\epsilon\psi)}{b(\epsilon\psi - 4)^3}$	> 0
$-\frac{\partial \pi_w}{\partial \epsilon}$	$\frac{(8A + 4a\psi)(A\epsilon - 2a + a\epsilon\psi)}{b(\epsilon\psi - 4)^3}$	> 0
$-\frac{\partial CS_P}{\partial \psi}$	$\frac{(4a + 2A\epsilon)(a\psi - 2A + A\epsilon\psi)}{B(\epsilon\psi - 4)^3}$	> 0
$-\frac{\partial CS_P}{\partial \epsilon}$	$\frac{\psi(2A + a\psi)(a\psi - 2A + A\epsilon\psi)}{B(\epsilon\psi - 4)^3}$	> 0
$-\frac{\partial CS_w}{\partial \psi}$	$\frac{\epsilon(2a + A\epsilon)(A\epsilon - 2a + a\epsilon\psi)}{b(\epsilon\psi - 4)^3}$	> 0
$-\frac{\partial CS_w}{\partial \epsilon}$	$\frac{(4A + 2a\psi)(A\epsilon - 2a + a\epsilon\psi)}{b(\epsilon\psi - 4)^3}$	> 0

continued on next page

continued from previous page

$-\frac{\partial SW}{\partial \psi}$	$-\frac{(2a + A\epsilon)((12Ab + 6Ba\epsilon - 3AB\epsilon^2) - \psi(6ab + 6Ab\epsilon + 3Ba\epsilon^2))}{Bb(\epsilon\psi - 4)^3}$	> 0
$-\frac{\partial SW}{\partial \epsilon}$	$-\frac{(2A + a\psi)((12Ba + 6Ab\psi - 3ab\psi^2) - \epsilon(6AB + 6Ba\psi + 3Ab\psi^2))}{Bb(\epsilon\psi - 4)^3}$	> 0

Table B.5: Effect of technology improvement on economic measures of case I-2A

	Value	Sign
$-\frac{\partial q}{\partial \psi}$	$\frac{2b(a - A\epsilon)}{(B\epsilon - 2b\psi)^2}$	> 0
$-\frac{\partial q}{\partial \epsilon}$	$-\frac{Ba - 2Ab\psi}{(B\epsilon - 2b\psi)^2}$	> 0
$-\frac{\partial w}{\partial \psi}$	$\frac{B\epsilon(a - A\epsilon)}{(B\epsilon - 2b\psi)^2}$	> 0
$-\frac{\partial w}{\partial \epsilon}$	$-\frac{Ba\psi - 2Ab\psi^2}{(B\epsilon - 2b\psi)^2}$	> 0
$-\frac{\partial \pi_P}{\partial \psi}$	$-\frac{(a - A\epsilon)(4Ab^2\psi - Bb((4a - 2A\epsilon) + 2A\epsilon^2\psi) + B^2a\epsilon^2)}{(B\epsilon - 2b\psi)^3}$	(1)
$-\frac{\partial \pi_P}{\partial \epsilon}$	$\frac{(Ba - 2Ab\psi)(AB\epsilon - 2Ba + 2Ab\psi - 2Ab\epsilon\psi^2 + Ba\epsilon\psi)}{(B\epsilon - 2b\psi)^3}$	(2)
$-\frac{\partial \pi_w}{\partial \psi}$	$-\frac{2Bb\epsilon\psi(a - A\epsilon)^2}{(B\epsilon - 2b\psi)^3}$	> 0
$-\frac{\partial \pi_w}{\partial \epsilon}$	$\frac{2b\psi^2(a - A\epsilon)(Ba - 2Ab\psi)}{(B\epsilon - 2b\psi)^3}$	> 0
$-\frac{\partial CS_P}{\partial \psi}$	$-\frac{2Bb(a - A\epsilon)^2}{(B\epsilon - 2b\psi)^3}$	> 0
$-\frac{\partial CS_P}{\partial \epsilon}$	$\frac{B^2a(a - A\epsilon) - 2ABb\psi(a - A\epsilon)}{(B\epsilon - 2b\psi)^3}$	> 0
$-\frac{\partial CS_w}{\partial \psi}$	$-\frac{Bb\epsilon\psi(a - A\epsilon)^2}{(B\epsilon - 2b\psi)^3}$	> 0
$-\frac{\partial CS_w}{\partial \epsilon}$	$\frac{b\psi^2(a - A\epsilon)(Ba - 2Ab\psi)}{(B\epsilon - 2b\psi)^3}$	> 0
$-\frac{\partial SW}{\partial \psi}$	$-\frac{(a - A\epsilon)(4Ab^2\psi - Bb(2a - \psi(3a\epsilon - 5A\epsilon^2)) + B^2a\epsilon^2)}{(B\epsilon - 2b\psi)^3}$	(3)

continued on next page

continued from previous page

$-\frac{\partial SW}{\partial \epsilon}$	$\frac{(Ba - 2Ab\psi)(2Ab\psi - Ba + 3ab\psi^2 - 5Abe\psi^2 + Ba\epsilon\psi)}{(B\epsilon - 2b\psi)^3}$	> 0
--	---	-------

$$1) \quad -\frac{\partial \pi_P}{\partial \psi} > 0 \quad \text{iff} \quad \frac{A\epsilon}{a} > \frac{B\epsilon(4b - B\epsilon^2)}{2b(B\epsilon(1 - \epsilon\psi) + 2b\psi)}$$

$$2) \quad -\frac{\partial \pi_P}{\partial \epsilon} > 0 \quad \text{iff} \quad \frac{A\epsilon}{a} < \frac{B\epsilon(2 - \epsilon\psi)}{B\epsilon + 2b\psi(1 - \epsilon\psi)}$$

$$3) \quad (3) - \frac{\partial SW}{\partial \psi} > 0 \quad \text{iff} \quad \frac{A\epsilon}{a} < -\frac{B\epsilon(B\epsilon^2 + 3b\psi\epsilon - 2b)}{b\psi(-5B\epsilon^2 + 4b)}$$

The values of the measures (1), (2), and (3) for case I-2B are the same as those of case I-2A, but the sign directions are opposite. The other measures are all positive in case 1-2B.

APPENDIX C:

ANALYSIS OF MODEL II

This section provides proofs of three of the possible equilibria of Model II. As discussed in the text, these equilibria result in positive outputs and profits. The KKT conditions of this model can be rewritten as follows:

$$A - 2Bq - (a - b(w_1 + w_2))\psi - \psi\lambda_1 \leq 0 \quad (\text{C.1})$$

$$a - 2bw_1 - bw_2 - (A - Bq)\epsilon - \epsilon\lambda_2 \leq 0 \quad (\text{C.2})$$

$$a - bw_1 - 2bw_2 - (A - Bq)\epsilon - \epsilon\lambda_2 \leq 0 \quad (\text{C.3})$$

$$\psi q - (w_1 + w_2) \leq 0 \quad (\text{C.4})$$

$$\epsilon(w_1 + w_2) - q \leq 0 \quad (\text{C.5})$$

$$(A - 2Bq - (a - b(w_1 + w_2))\psi - \psi\lambda_1)q = 0 \quad (\text{C.6})$$

$$(a - 2bw_1 - bw_2 - (A - Bq)\epsilon - \epsilon\lambda_2)w_1 = 0 \quad (\text{C.7})$$

$$(a - bw_1 - 2bw_2 - (A - Bq)\epsilon - \epsilon\lambda_2)w_2 = 0 \quad (\text{C.8})$$

$$(\psi q - (w_1 + w_2))\lambda_1 = 0 \quad (\text{C.9})$$

$$(\epsilon(w_1 + w_2) - q)\lambda_2 = 0 \quad (\text{C.10})$$

$$q \geq 0 \quad (\text{C.11})$$

$$w_1 \geq 0 \quad (\text{C.12})$$

$$w_2 \geq 0 \quad (\text{C.13})$$

$$\lambda_1 \geq 0 \quad (\text{C.14})$$

$$\lambda_2 \geq 0 \quad (\text{C.15})$$

C.1 Proof of the equilibrium of case II-1

In this case, it is assumed that $\lambda_1 = 0$ and $\lambda_2 = 0$

From (C.6),

$$q = \frac{(A - \psi(a - bw_1 - bw_2))}{2B} \quad (\text{C.1.1})$$

From (C.7),

$$w_1 = \frac{(a - bw_2 - \epsilon(A - Bq))}{2b} \quad (\text{C.1.2})$$

From (C.8),

$$w_2 = \frac{(a - bw_1 - \epsilon(A - Bq))}{2b} \quad (\text{C.1.3})$$

From (C.1.2) into (C.1.1), the best response of the power supplier:

$$q^{BR} = -\frac{2A - a\psi - A\epsilon\psi + b\psi w_2}{B(\epsilon\psi - 4)} \quad (\text{C.1.4})$$

The best response of the water supplier (from (C.1.2) into (C.1.3)):

$$w_2^{BR} = \frac{(a - \epsilon(A - Bq))}{3b} \quad (\text{C.1.5})$$

The optimal outputs of the water supplier (from (C.1.4) into (C.1.5)):

$$w_2 = \frac{A\epsilon - 2a + a\epsilon\psi}{2b(\epsilon\psi - 3)} \quad (\text{C.1.6})$$

and the optimal output of the power supplier ((C.1.6) into (C.1.4)):

$$q = \frac{a\psi - 3A + 2A\epsilon\psi}{2B(\epsilon\psi - 3)} \quad (\text{C.1.7})$$

From (C.1.6) and (C.1.7) into (C.1.2) (although it's obvious that w_1 and w_2 are symmetric)

$$w_1 = \frac{A\epsilon - 2a + a\epsilon\psi}{2b(\epsilon\psi - 3)} \quad (\text{C.1.8})$$

From (C.4), the demand of water by the power supplier should not exceed the available water

$$\psi q \leq w_1 + w_2 \quad (\text{C.1.9})$$

From (C.5), the demand of power by the water suppliers should not exceed the available power

$$\epsilon(w_1 + w_2) \leq q \quad (\text{C.1.10})$$

From (C.1.9) and (C.1.10),

$$\epsilon\psi \leq 1 \quad (\text{C.1.11})$$

Given (C.1.11), the denominators of (C.1.6), (C.1.7) and (8) are negative; thus, the numerators must be negative. From (C.1.6) and (C.1.8),

$$\frac{A\epsilon}{a} < 2 - \epsilon\psi \quad (\text{C.1.12})$$

From (C.1.7),

$$\frac{A\epsilon}{a} > \frac{\epsilon\psi}{(3 - 2\epsilon\psi)} \quad (\text{C.1.13})$$

From (C.1.12) and (C.1.13),

$$\frac{\epsilon\psi}{(3 - 2\epsilon\psi)} < \frac{A\epsilon}{a} < 2 - \epsilon\psi \quad (\text{C.1.14})$$

From (C.1.14),

if $\epsilon\psi = 1$, then $\frac{\epsilon\psi}{(3 - 2\epsilon\psi)} = 2 - \epsilon\psi$, which contradicts (C.1.14)

Thus,

$$\epsilon\psi < 1 \quad (\text{C.1.11}')$$

From (C.1.6), (C.1.7) and (C.1.8) into (C.4) and (EE),

$$\frac{(b\psi + 2B\epsilon(2 - \epsilon\psi))\epsilon}{(2B\epsilon^2 + (3 - 2\epsilon\psi)b)} \leq \frac{A\epsilon}{a} \leq \frac{(b\psi^2 + 4B - 2B\epsilon\psi)\epsilon}{(2B\epsilon + 3b\psi - 2b\epsilon\psi^2)} \quad (\text{C.1.15})$$

Comparing the RHSs and LHSs of (C.1.14) and (C.1.15), we find that (C.1.15) is a subset of (C.1.14).

Summary of input conditions:

$$\epsilon\psi < 1 \text{ and } \frac{(b\psi + 2B\epsilon(2 - \epsilon\psi))\epsilon}{(2B\epsilon^2 + (3 - 2\epsilon\psi)b)} \leq \frac{A\epsilon}{a} \leq \frac{(b\psi^2 + 4B - 2B\epsilon\psi)\epsilon}{(2B\epsilon + 3b\psi - 2b\epsilon\psi^2)}$$

C.2 Proof of the equilibrium of case II-2

In this case, it is assumed that $\lambda_1 > 0$ and $\lambda_2 = 0$

From (C.6),

$$q = \frac{(A - \psi(a - bw_1 - bw_2 - \lambda_1))}{2B} \quad (\text{C.2.1})$$

From (C.7),

$$w_1 = \frac{(a - bw_2 - \epsilon(A - Bq))}{2b} \quad (\text{C.2.2})$$

From (C.8),

$$w_2 = \frac{(a - bw_1 - \epsilon(A - Bq))}{2b} \quad (\text{C.2.3})$$

From (C.9),

$$\psi q = (w_1 + w_2) \quad (\text{C.2.4})$$

Solving (C.2.1)-(C.2.4), we find the following equilibrium outputs and shadow price:

$$q = -\frac{2(a - A\epsilon)}{2B\epsilon - 3b\psi} \quad (\text{C.2.5})$$

$$w_1 = w_2 = -\frac{\psi(a - A\epsilon)}{2B\epsilon - 3b\psi} \quad (\text{C.2.6})$$

$$\lambda_1 = \frac{4Ba - 2AB\epsilon - 3Ab\psi + ab\psi^2 + 2Abe\psi^2 - 2Ba\epsilon\psi}{\psi(2B\epsilon - 3b\psi)} \quad (\text{C.2.7})$$

From (C.2.5)-(C.2.7),

If $\frac{B\epsilon}{b\psi} = \frac{3}{2}$, no solution exists

If $\frac{B\epsilon}{b\psi} > \frac{3}{2}$,

$$1 < \frac{A\epsilon}{a} < \frac{(b\psi^2 + 4B - 2B\epsilon\psi)\epsilon}{(2B\epsilon + 3b\psi - 2be\psi^2)}$$

If $\frac{B\epsilon}{b\psi} < \frac{3}{2}$,

$$\frac{(b\psi^2 + 4B - 2B\epsilon\psi)\epsilon}{(2B\epsilon + 3b\psi - 2be\psi^2)} < \frac{A\epsilon}{a} < 1$$

From (C.4),

$$\epsilon(w_1 + w_2) \leq q \quad (\text{C.2.8})$$

From (C.9),

$$q = \frac{w_1 + w_2}{\psi} \quad (\text{C.2.9})$$

From (C.2.9) and (C.2.10),

$$\epsilon\psi \leq 1 \quad (\text{C.2.10})$$

If $\epsilon\psi = 1$,

$$\frac{A\epsilon}{a} < \frac{\epsilon(b\psi^2 + 4B - 2B\epsilon\psi)}{(2B\epsilon + 3b\psi - 2be\psi^2)} = 1, \quad \text{which is not possible}$$

Thus,

$$\epsilon\psi < 1 \quad (\text{C.2.10}')$$

Summary of input conditions:

$$\psi\epsilon < 1, \quad \frac{B\epsilon}{b\psi} < \frac{3}{2} \quad \text{and} \quad \frac{(b\psi^2 + 4B - 2B\epsilon\psi)\epsilon}{(2B\epsilon + 3b\psi - 2b\epsilon\psi^2)} < \frac{A\epsilon}{a} < 1 \quad (\text{case II-2.A}), \quad \text{or}$$

$$\psi\epsilon < 1, \quad \frac{B\epsilon}{b\psi} > \frac{3}{2} \quad \text{and} \quad 1 < \frac{A\epsilon}{a} < \frac{(b\psi^2 + 4B - 2B\epsilon\psi)\epsilon}{(2B\epsilon + 3b\psi - 2b\epsilon\psi^2)} \quad (\text{case II-2.B}) \quad \square$$

C.3 Proof of the equilibrium of case II-3

Following the same logic of case II-2, the Nash equilibrium outputs of the water supplier and the power supplier are as follow:

$$q = \frac{\epsilon(A - a\psi)}{2B\epsilon - b\psi}$$

$$w_1 = w_2 = \frac{A - a\psi}{2(2B\epsilon - b\psi)}$$

$$\lambda_2 = -\frac{3Ab - 4Ba\epsilon - ab\psi + 2AB\epsilon^2 + 2Ba\epsilon^2\psi - 2Ab\epsilon\psi}{2\epsilon(2B\epsilon - b\psi)}$$

Summary of input conditions:

$$\psi\epsilon < 1, \quad \frac{B\epsilon}{b\psi} > \frac{1}{2} \quad \text{and} \quad \epsilon\psi < \frac{A\epsilon}{a} < \frac{\epsilon(b\psi + (2 - \epsilon\psi)2B\epsilon)}{(2B\epsilon^2 + (3 - 2\epsilon\psi)b)} \quad (\text{case II-3.A}), \quad \text{or}$$

$$\psi\epsilon < 1, \quad \frac{B\epsilon}{b\psi} < \frac{1}{2} \quad \text{and} \quad \frac{\epsilon(b\psi + (2 - \epsilon\psi)2B\epsilon)}{(2B\epsilon^2 + (3 - 2\epsilon\psi)b)} < \frac{A\epsilon}{a} < \epsilon\psi \quad (\text{case II-2.B}) \quad \square$$

C.4 Economic measures of Model II

Table C.1: Economic measures of case II-1

Economic Measure	Value
q	$\frac{a\psi - 3A + 2A\epsilon\psi}{2B(\epsilon\psi - 3)}$
$w_1 = w_2$	$\frac{A\epsilon - 2a + a\epsilon\psi}{2b(\epsilon\psi - 3)}$
π_P	$\frac{(a\psi - 3A + 2A\epsilon\psi)^2}{4B(\epsilon\psi - 3)^2}$
$\pi_{w_1} = \pi_{w_2}$	$\frac{(A\epsilon - 2a + a\epsilon\psi)^2}{4b(\epsilon\psi - 3)^2}$
CS_P	$\frac{(a\psi - 3A + 2A\epsilon\psi)^2}{8B(\epsilon\psi - 3)^2}$
CS_W	$\frac{(A\epsilon - 2a + a\epsilon\psi)^2}{2b(\epsilon\psi - 3)^2}$
PS_p	$\frac{(a\psi - 3A + 2A\epsilon\psi)^2}{4B(\epsilon\psi - 3)^2}$
PS_w	$\frac{(A\epsilon - 2a + a\epsilon\psi)^2}{2b(\epsilon\psi - 3)^2}$
SW	$2(\pi_{W_1} + \pi_{W_2}) + \frac{3}{2}\pi_P$

Table C.2: Economic measures of case II-2

Economic Measure	Value
q	$\frac{2(a - A\epsilon)}{2B\epsilon - 3b\psi}$
$w_1 = w_2$	$\frac{a\psi - A\epsilon\psi}{2B\epsilon - 3b\psi}$
π_P	$-\frac{(a - A\epsilon)(4Ba(1 - \epsilon\psi) + 2b\psi(a\psi - 3A + 2A\epsilon\psi))}{(2B\epsilon - 3b\psi)^2}$
$\pi_{w_1} = \pi_{w_2}$	$\frac{b\psi^2(a - A\epsilon)^2}{(2B\epsilon - 3b\psi)^2}$
CS_P	$\frac{2B(a - A\epsilon)^2}{(2B\epsilon - 3b\psi)^2}$
CS_W	$\frac{2b\psi^2(a - A\epsilon)^2}{(2B\epsilon - 3b\psi)^2}$
PS_p	$-\frac{(a - A\epsilon)(4Ba(1 - \epsilon\psi) + 2b\psi(a\psi - 3A + 2A\epsilon\psi))}{(2B\epsilon - 3b\psi)^2}$
PS_w	$\frac{2b\psi^2(a - A\epsilon)^2}{(2B\epsilon - 3b\psi)^2}$
SW	$\frac{(a - A\epsilon)(b\psi(a\psi - 7A\epsilon\psi + 3A) - 2B(a + A\epsilon - 2a\epsilon\psi))}{(2B\epsilon - 3b\psi)^2}$

Table C.3: Economic measures of case II-3

Economic Measure	Value
q	$\frac{A\epsilon - a\epsilon\psi}{2B\epsilon - b\psi}$
$w_1 = w_2$	$\frac{A - a\psi}{4B\epsilon - 2b\psi}$
π_P	$\frac{B\epsilon^2 (A - a\psi)^2}{(2B\epsilon - b\psi)^2}$
$\pi_{w_1} = \pi_{w_2}$	$-\frac{(A - a\psi)(Ab(1 - \epsilon\psi) + B\epsilon(A\epsilon - 2a + a\epsilon\psi))}{2(2B\epsilon - b\psi)^2}$
CS_P	$\frac{B\epsilon^2 (A - a\psi)^2}{2(2B\epsilon - b\psi)^2}$
CS_W	$\frac{b(A - a\psi)^2}{4(2B\epsilon - b\psi)^2}$
PS_p	$\frac{B\epsilon^2 (A - a\psi)^2}{(2B\epsilon - b\psi)^2}$
PS_w	$-\frac{(A - a\psi)(Ab(1 - \epsilon\psi) + B\epsilon(A\epsilon - 2a + a\epsilon\psi))}{(2B\epsilon - b\psi)^2}$
SW	$-\frac{(A - a\psi)(Ab(1 - 2\epsilon\psi) - 4B\epsilon(a + A\epsilon - 2a\epsilon\psi) + ab\psi)}{4(2B\epsilon - b\psi)^2}$

C.5 Proof of the effect of competition on the producer surplus of the water market (case 1)

The producer surplus of the water industry of case II-1 is larger than that of the water industry of case I-1 if and only if $\epsilon\psi > 2 - \sqrt{2}$ when both input conditions of Propositions 1 and 4 are met.

Proof:

$$PS_w^{2,1} - PS_w^{1,1} = \frac{(\epsilon^2\psi^2 - 4\epsilon\psi + 2)(A\epsilon - 2a + a\epsilon\psi)^2}{-2b(-7\epsilon\psi + \epsilon^2\psi^2 + 12)^2}$$

The denominator is negative. The numerator is negative if and only if $\epsilon^2\psi^2 - 4\epsilon\psi + 2 < 0$.

Given $\epsilon\psi < 1$, we have $PS_w^{2,1} > PS_w^{1,1}$ iff $\epsilon\psi > 2 - \sqrt{2}$ \square

C.6 Proof of the effect of competition on the producer surplus of the power market (case 1)

The producer surplus of the power supplier in a supply chain with water competition is always greater than its profit when there is a monopolist water supplier in the supply chain when both input conditions of Propositions 1 and 4 are met.

Proof:

Factoring $PS_p^{2,1} - PS_p^{1,1}$, we get the factors below:

$$-1/4 < 0 \tag{C.6.1}$$

$$\psi > 0 \tag{C.6.2}$$

$$4A\epsilon^2\psi^2 + 3a\epsilon\psi^2 - 21A\epsilon\psi - 10a\psi + 24A > 0 \text{ (see proof below)} \tag{C.6.3}$$

$$A\epsilon - 2a + a\epsilon\psi < 0 \tag{C.6.4}$$

$$1/B > 0 \tag{C.6.5}$$

$$(1/(\epsilon\psi - 4))^2 > 0 \tag{C.6.6}$$

$$(1/(\epsilon\psi - 3))^2 > 0 \tag{C.6.7}$$

Notice that (C.6.4) is negative from the positivity condition of case II-1. Thus, $PS_p^{2,1} - PS_p^{1,1} > 0$ iff (C.6.3) is positive. Let us assume it is positive and solve for $A\epsilon/a$,

$$\frac{A\epsilon}{a} > \frac{\epsilon\psi(10 - 3\epsilon\psi)}{4\epsilon^2\psi^2 - 21\epsilon\psi + 24}$$

This condition is a superset of the $A\epsilon/a$ range of cases I-1 and II-1, thus $PS_p^{2,1} > PS_p^{1,1}$ \square

C.7 Proof of the effect of competition on the consumer surplus of the water market (case 1)

The consumer surplus of the water industry in a supply chain with water competition is greater than that with a monopolist water supplier; when both input conditions of Propositions 1 and 4 are met.

Proof:

$$CS_w^{2,1} - CS_w^{1,1} = \frac{(7 - 2\epsilon\psi)(A\epsilon - 2a + a\epsilon\psi)^2}{2b(-7\epsilon\psi + \epsilon^2\psi^2 + 12)^2}$$

since $\epsilon\psi < 1$, $CS_w^{2,1} > CS_w^{1,1}$ \square

C.8 Proof of the effect of competition on the consumer surplus of the power market (case 1)

The consumer surplus of the power industry in a supply chain with water competition is greater than that of with a monopolist water supplier when both input conditions of Propositions 1 and 4 are met.

Proof:

$$CS_p^{2,1} - CS_p^{1,1} = \frac{(a\psi - 3A + 2A\epsilon\psi)^2}{4B(\epsilon\psi - 3)(2\epsilon\psi - 6)} - \frac{(a\psi - 2A + A\epsilon\psi)^2}{2B(\epsilon\psi - 4)^2}$$

$$CS_p^{2,1} - CS_p^{1,1} > 0 \quad \text{if} \quad \frac{\epsilon\psi(10 - 3\epsilon\psi)}{4\epsilon^2\psi^2 - 21\epsilon\psi + 24} < \frac{A\epsilon}{a} < 2 - \epsilon\psi$$

which is true since this condition is a superset of the $A\epsilon/a$ condition of case 1. Thus, $CS_p^{2,1} > CS_p^{1,1}$ \square

APPENDIX D:

ANALYSIS OF MODEL III

D.1 Economic measures of Model III

Table D.1: Economic measures of case III-1

Economic Measure	Value
$q_0 = q_i$	$\frac{a\psi - Am - 2A + A\epsilon\psi + A\epsilon m\psi}{B(2m + 2n - \epsilon\psi + mn - \epsilon m\psi - \epsilon n\psi - \epsilon mn\psi + 4)}$
$w_0 = w_j$	$\frac{A\epsilon - 2a - an + a\epsilon\psi + a\epsilon n\psi}{b(2m + 2n - \epsilon\psi + mn - \epsilon m\psi - \epsilon n\psi - \epsilon mn\psi + 4)}$
$\pi_{p,0} = \pi_{p,i}$	$\frac{(a\psi - Am - 2A + A\epsilon\psi + A\epsilon m\psi)^2}{B(2m + 2n - \epsilon\psi + mn - \epsilon m\psi - \epsilon n\psi - \epsilon mn\psi + 4)^2}$
$\pi_{w,0} = \pi_{w,j}$	$\frac{(A\epsilon - 2a - an + a\epsilon\psi + a\epsilon n\psi)^2}{b(2m + 2n - \epsilon\psi + mn - \epsilon m\psi - \epsilon n\psi - \epsilon mn\psi + 4)^2}$
CS_P	$\frac{(n + 1)^2 (a\psi - Am - 2A + A\epsilon\psi + A\epsilon m\psi)^2}{2B(2m + 2n - \epsilon\psi + mn - \epsilon m\psi - \epsilon n\psi - \epsilon mn\psi + 4)^2}$
CS_W	$\frac{(m + 1)^2 (A\epsilon - 2a - an + a\epsilon\psi + a\epsilon n\psi)^2}{2b(2m + 2n - \epsilon\psi + mn - \epsilon m\psi - \epsilon n\psi - \epsilon mn\psi + 4)^2}$
PS_p	$\frac{(n + 1) (a\psi - Am - 2A + A\epsilon\psi + A\epsilon m\psi)^2}{B(2m + 2n - \epsilon\psi + mn - \epsilon m\psi - \epsilon n\psi - \epsilon mn\psi + 4)^2}$
PS_w	$\frac{(m + 1) (A\epsilon - 2a - an + a\epsilon\psi + a\epsilon n\psi)^2}{b(2m + 2n - \epsilon\psi + mn - \epsilon m\psi - \epsilon n\psi - \epsilon mn\psi + 4)^2}$
SW	$CS_p + CS_w + PS_p + PS_w$

Table D.2: Economic measures of case III-2

Economic Measure	Value
$q_0 = q_i$	$-\frac{a - A\epsilon + am - A\epsilon m}{(n+1)(B\epsilon - 2b\psi + B\epsilon m - bm\psi)}$
$w_0 = w_j$	$-\frac{a\psi - A\epsilon\psi}{B\epsilon - 2b\psi + B\epsilon m - bm\psi}$
$\pi_{p,0} = \pi_{p,i}$	$\frac{z(b\psi(a\psi + A(-2 + \epsilon\psi - m + \epsilon m\psi)) + Ba(1 + m - \epsilon\psi - \epsilon m\psi))}{(n+1)(B\epsilon - 2b\psi + B\epsilon m - bm\psi)^2}$
$\pi_{w,0} = \pi_{w,j}$	$\frac{b\psi^2(a - A\epsilon)^2}{(B\epsilon - 2b\psi + B\epsilon m - bm\psi)^2}$
CS_P	$\frac{B(a - A\epsilon)^2(m+1)^2}{2(B\epsilon - 2b\psi + B\epsilon m - bm\psi)^2}$
CS_W	$\frac{b\psi^2(a - A\epsilon)^2(m+1)^2}{2(B\epsilon - 2b\psi + B\epsilon m - bm\psi)^2}$
PS_p	$\frac{z(b\psi(a\psi + A(-2 + \epsilon\psi - m + \epsilon m\psi)) + Ba(1 + m - \epsilon\psi - \epsilon m\psi))}{(B\epsilon - 2b\psi + B\epsilon m - bm\psi)^2}$
PS_w	$\frac{b\psi^2(a - A\epsilon)^2(m+1)}{(B\epsilon - 2b\psi + B\epsilon m - bm\psi)^2}$
SW	$CS_p + CS_w + PS_p + PS_w$

* $z = (A\epsilon - a)(m+1)$

D.2 Proof of the effect of competition on the total output of the same industry (case III-1)

In the normal case, increasing the number of firms in one industry increases the total output of that industry.

$$\frac{\partial Q^{3,1}}{\partial n} = -\frac{(m+2)(a\psi - Am - 2A + A\epsilon\psi + A\epsilon m\psi)}{B(2m + 2n - \epsilon\psi + mn - \epsilon m\psi - \epsilon n\psi - \epsilon mn\psi + 4)^2} > 0$$

For the numerator:

$a\psi - Am - 2A + A\epsilon\psi + A\epsilon m\psi < 0$ always holds based on the positivity conditions of q_i^1

For the denominator:

$$2m + 2n - \epsilon\psi + mn - \epsilon m\psi - \epsilon n\psi - \epsilon mn\psi + 4 > 0 \text{ always holds since } \epsilon\psi < 1 \quad \square$$

D.3 Proof of the effect of competition on individual outputs and profits of the firms in the same industry (case III-1)

In the normal case, increasing the number of firms in one industry decreases the individual output of firms in that industry.

$$\frac{\partial q_i^{3,1}}{\partial n} = \frac{(2 + m - \epsilon\psi - \epsilon m\psi)(a\psi - Am - 2A + A\epsilon\psi + A\epsilon m\psi)}{B(2m + 2n - \epsilon\psi + mn - \epsilon m\psi - \epsilon n\psi - \epsilon mn\psi + 4)^2} < 0$$

$$\frac{\partial \pi_{p,i}^{3,1}}{\partial n} = -\frac{2(2 + m - \epsilon\psi - \epsilon m\psi)(a\psi - Am - 2A + A\epsilon\psi + A\epsilon m\psi)^2}{B(2m + 2n - \epsilon\psi + mn - \epsilon m\psi - \epsilon n\psi - \epsilon mn\psi + 4)^3} < 0$$

For the numerators:

$$a\psi - Am - 2A + A\epsilon\psi + A\epsilon m\psi < 0 \text{ always holds based on the positivity conditions of } q_i^1$$

$$2 + m - \epsilon\psi - \epsilon m\psi > 0 \text{ always holds since } \epsilon\psi < 1$$

For the denominator:

$$2m + 2n - \epsilon\psi + mn - \epsilon m\psi - \epsilon n\psi - \epsilon mn\psi + 4 > 0 \text{ always holds since } \epsilon\psi < 1 \quad \square$$

D.4 Proof of the effect of competition on the total output of the cross industry (case III-1)

In the normal case, increasing the number of firms in one industry increases the total output of the cross industry.

$$\frac{\partial Q^{3,1}}{\partial m} = -\frac{\psi (n+1) (A\epsilon - 2a - an + a\epsilon\psi + a\epsilon n\psi)}{B (2m + 2n - \epsilon\psi + mn - \epsilon m\psi - \epsilon n\psi - \epsilon mn\psi + 4)^2} > 0$$

For the numerator:

$$A\epsilon - 2a - an + a\epsilon\psi + a\epsilon n < 0 \quad \text{always holds based on the positivity conditions of } w_j^1$$

For the denominator:

$$2m + 2n - \epsilon\psi + mn - \epsilon m\psi - \epsilon n\psi - \epsilon mn\psi + 4 > 0 \quad \text{always holds since } \epsilon\psi < 1 \quad \square$$

D.5 Proof of the effect of competition on individual outputs and profit of firms in the cross industry (case III-1)

In the normal case, increasing the number of firms in one industry increases the individual output of firms in the cross industry.

$$\frac{\partial q_i^{3,1}}{\partial m} = -\frac{\psi (A\epsilon - 2a - an + a\epsilon\psi + a\epsilon n\psi)}{B (2m + 2n - \epsilon\psi + mn - \epsilon m\psi - \epsilon n\psi - \epsilon mn\psi + 4)^2} > 0$$

$$\frac{\partial \pi_{p,i}^{3,1}}{\partial m} = \frac{2\psi (a\psi - Am - 2A + A\epsilon\psi + A\epsilon m\psi) (A\epsilon - 2a - an + a\epsilon\psi + a\epsilon n\psi)}{B (2m + 2n - \epsilon\psi + mn - \epsilon m\psi - \epsilon n\psi - \epsilon mn\psi + 4)^3} > 0$$

For the numerators:

$A\epsilon - 2a - an + a\epsilon\psi + a\epsilon n < 0$ always holds based on the positivity conditions of w_j^1

$a\psi - Am - 2A + A\epsilon\psi + A\epsilon m\psi < 0$ always holds based on the positivity conditions of q_j^1

For the denominators:

$2m + 2n - \epsilon\psi + mn - \epsilon m\psi - \epsilon n\psi - \epsilon mn\psi + 4 > 0$ always holds since $\epsilon\psi < 1$ \square

D.6 Proof of the effect of competition on consumer surplus (case III-1)

In the normal case, increasing the number of firms in one industry increases the consumer surplus of the same industry as well as the cross industry.

$$\frac{\partial CS_p^{3,1}}{\partial n} = \frac{(m+2)(n+1)(a\psi - Am - 2A + A\epsilon\psi + A\epsilon m\psi)^2}{B(2m + 2n - \epsilon\psi + mn - \epsilon m\psi - \epsilon n\psi - \epsilon mn\psi + 4)^3} > 0$$

$$\frac{\partial CS_p^{3,1}}{\partial m} = \frac{\psi(n+1)^2(a\psi - Am - 2A + A\epsilon\psi + A\epsilon m\psi)(A\epsilon - 2a - an + a\epsilon\psi + a\epsilon n\psi)}{B(2m + 2n - \epsilon\psi + mn - \epsilon m\psi - \epsilon n\psi - \epsilon mn\psi + 4)^3} > 0$$

The first equation is positive, and the second equation is proven positive in Appendix D.5 \square

D.7 Proof of the effect of competition on individual outputs of the cross industry (case III-2)

In the case where the power industry buys all water, increasing the number of firms in the water industry increases the individual output of firms in the power industry if and only if the reservation price of power is low and the water suppliers are efficient.

$$\frac{\partial q_i^{3,2}}{\partial m} = \frac{b\psi(a - A\epsilon)}{(n+1)(B\epsilon - 2b\psi + B\epsilon m - bm\psi)^2}$$

$$\frac{\partial q_i^{3,2}}{\partial m} > 0 \text{ if } \frac{A\epsilon}{a} < 1$$

$$\frac{\partial q_i^{3,2}}{\partial m} > 0 \text{ if } \frac{A\epsilon}{a} > 1 \quad \square$$

D.8 Proof of the effect of competition on individual outputs of the same industry (case III-2)

In the case where the power industry buys all water, increasing the number of firms in the water industry increases the individual output of firms in the water industry if and only if the reservation price of power is low and the water suppliers are efficient, and the marginal price of power is in the higher end of the range.

$$\frac{\partial w_j^{3,2}}{\partial m} = \frac{\psi(B\epsilon - b\psi)(a - A\epsilon)}{(B\epsilon - 2b\psi + B\epsilon m - bm\psi)^2}$$

From the numerator, the only possible conditions are:

$$\frac{\partial w_j^{3,2}}{\partial m} > 0 \text{ if } \frac{A\epsilon}{a} < 1 \text{ and } \frac{B\epsilon}{b\psi} > 1$$

$$\frac{\partial w_j^{3,2}}{\partial m} < 0 \text{ if } \frac{A\epsilon}{a} < 1 \text{ and } \frac{B\epsilon}{b\psi} < 1$$

$$\frac{\partial w_j^{3,2}}{\partial m} < 0 \text{ if } \frac{A\epsilon}{a} > 1 \text{ and } \frac{B\epsilon}{b\psi} > 1 \text{ (from the condition of case III-2.B, } \frac{B\epsilon}{b\psi} > 2) \quad \square$$

Nabeel Hamoud

EDUCATION

- PhD in Industrial Engineering (Operations Research track, minor in Business)** (Dec 2019)
University of Wisconsin – Milwaukee
Dissertation title: *A Game Modeling of a Closed-Loop Supply Chain in a Water-Energy Nexus: Technology Advancement, Market Competition and Capacity Limit*
- Master of Engineering Management** (Dec 2010)
University of Technology Sydney
- Bachelor of Science, Engineering Geology** (May 2006)
King Abdul Aziz University

WORK EXPERIENCE

- Graduate Teaching Assistant at the University of Wisconsin - Milwaukee** (Jan 2014 – Dec 2019)
- Teach Statistics & Operations Research.
 - Develop and maintain lab manuals.
- Data Science Consultant at DrFirst Inc.** (Jun 2019 – Aug 2019)
- Perform image processing using Computer Vision.
 - Build image classification models with Deep Learning.
 - Build data preprocess pipelines with Python.
- Data Science Intern at DrFirst Inc.** (Jun 2018 – Aug 2018)
- Perform data and text preprocessing.
 - Build NLP machine learning models.
 - Visualize data and build UIs and dashboards.
- President of the Student Chapter of INFORMS at UWM** (Sep 2017 – Sep 2018)
- Organize events in the area of Operations Research and Analytics.
 - Attended and presented at conferences.
- Operations Coordinator at Saudi Oger** (Jun 2011 – Mar 2012)
- Leader of 10 skilled technicians.
 - Analyze and report historical data.
- Customer Service Representative at Alawal Bank** (Jun 2007 – Aug 2008)
- Customer service.
 - Banking product sales.
- Call Center Agent at Saudi Airlines** (Jun 2007 – Aug 2008)
- Customer service.
 - Booking and sales.

PUBLICATIONS AND PRESENTATIONS

- Hamoud N, Jang J. “The Effect of Technology Efficiency and Market Competition on a Closed-Loop Water-Energy Nexus”. International Journal of Energy Research. 2019 (Under review).
- Hu X, Jang J, Hamoud N., and Bajgiran A., “Strategic Inventories in a Supply Chain with Downstream Cournot Duopoly,” Int. J. of Operational Research (Accepted in June 2019, In press).
- Presented at INFORMS 2017 Annual Conference in Houston, TX, USA. “Game Theoretic Modeling of Water Energy Nexus in the Presence of Competition Between Interdependent Firms”.
- Presented at the Student Research Poster Competition 2017. “Game Theoretic Modelling of Water-Energy Nexus Revealing the Impact of Competition Within and Between Industries”.

OPERATIONS RESEARCH & DATA SCIENCE PROJECTS

- Optimization of a Water-Energy Nexus with uncapacitated non-identical power plants
 - Built a Mixed Complementarity Problem (MCP) model.
 - Performed sensitivity analysis of the Nash Equilibrium.
- Optimization of a Pin Cell operations at JoyGlobal
 - Improved the throughput of the Pin Cell by 20% by optimizing the layout of the cell and the working schedule of the operators.
- Image Recognition and Classification using OpenCV and Keras:
 - Built a pipeline to preprocess images.
 - Built image classification models.
- Topic Modelling: Word2Vec and Doc2Vec models using Gensim library
 - Built Word2Vec and Doc2Vec models.
 - Performed similarity analysis on physicians’ notes.

ANALYTICAL SKILLS

- Optimization
- Statistics and Probability
- Supervised Machine Learning
- Unsupervised Machine Learning
- Natural Language Processing
- Data Analysis and Data Visualization
- Relational databases

TECHNICAL TOOLS

- Python: Numpy, Pandas, SciKit Learn, OpenCV, Gensim, Keras, Flask
- Web Dev: JavaScript, HTML, CSS
- Optimization: Cplex, GAMS, Matlab
- Simulation: ProModel
- Others: Git, SQL Database, Tableau, Excel, Minitab, SAS, MS Project