

**LATERAL REPLACEMENT OF THE LUX OPERON IN A *VIBRIO*
ISOLATED FROM THE INTESTINE OF A CORAL REEF FISH**

by

Melissa Lee Whyte

A Thesis Submitted in
Partial Fulfillment of the
Requirements for the Degree of
Master of Science
in Biological Sciences
at
The University of Wisconsin-Milwaukee
August 2016

ABSTRACT

LATERAL REPLACEMENT OF THE LUX OPERON IN A VIBRIO ISOLATED FROM THE INTESTINE OF A CORAL REEF FISH

by

Melissa Whyte

The University of Wisconsin-Milwaukee, 2016
Under the Supervision of Professor Charles Wimpee

In a screening of bioluminescent bacteria isolated from the intestines of coral reef fish, two strains (designated D6 and M1) were identified that have a *luxA* gene sequence significantly different from those of other *Vibrio* species. Phylogenetic analysis of several housekeeping genes, as well as *toxR*, shows that D6 and M1 branch within a bioluminescent clade (designated the “D1 group,” isolated at the same time and place as D6 and M1) that is a close sister group to *Vibrio harveyi*. However, whereas the *luxA* genes of the D1 group are >98% identical to *V. harveyi luxA*, the *luxA* genes of D6 and M1 have a surprisingly low identity (86%) to the D1 group and to *V. harveyi*. Strain D6 and strain D1 (a representative of the D1 group) were chosen for further investigation. The *lux* operons (*luxCDABEGH*) and flanking regions of both strains were cloned into *E. coli* and sequenced by primer walking. Although distinguishable from *Vibrio harveyi*, and possibly representing a new species, strain D1 is clearly a close relative, and has the same genes flanking the *lux* operon as *V. harveyi*. However, in addition to a highly divergent *lux* operon, the flanking regions of D6 are completely different from those of D1 and *V. harveyi*.

Based on differences in *luxCDABEGH* sequence and chromosomal context, we conclude that the lux operon of D6 was acquired by lateral gene transfer. PCR and Southern hybridizations show that D6 contains a single lux operon, so we conclude that this operon represents not simply a lateral transfer, but a lateral replacement of the original operon. We also show, in an *E. coli* expression system, that the lux operons of both D1 and D6 are up-regulated by the *V. harveyi* LuxR protein, indicating evolutionary conservation of lux gene regulation, despite the high degree of sequence dissimilarity between the two. These results show that we have not exhausted the diversity of bioluminescence genes in bacteria.

© Copyright by Melissa Whyte, 2016
All Rights Reserved

TABLE OF CONTENTS

Abstract	ii
List of Figures	vii
List of Tables	viii
Acknowledgements	ix
Introduction	1
Bioluminescence.....	1
Bacterial Bioluminescence.....	4
The lux operon.....	7
Biochemistry of bacterial bioluminescence.....	11
Transcriptional regulation of the lux operon in bacteria.....	13
Hypothesis	16
Methods and Materials	17
Bacterial Strains.....	17
Media.....	17
Gel electrophoresis and imaging.....	18
Polymerase chain reaction.....	18
Sequence analysis.....	19
Phylogenetic analysis.....	20
Cloning of the lux operon from strain D1.....	23
Dual plasmid arabinose-inducible LuxR _{VH} system.....	24
Quorum sensing assays.....	24
Southern hybridization.....	25
Results	26

Sequence Analysis.....	26
Phylogenetic Analysis.....	31
Transcriptional regulation of the lux operon.....	34
Quorum Sensing.....	36
Copy number of the lux operon.....	38
Discussion.....	40
Lateral transfer of the lux operon in D6.....	40
Lateral replacement of the ancestral lux operon in D6.....	43
The D1 group of bioluminescent bacteria.....	43
Implications of lateral gene transfer in bacterial evolution.....	44
Conclusion.....	48
References.....	50
Appendix: Phylogenetic analysis of various conserved genes in bioluminescent bacteria.....	58

LIST OF FIGURES

<u>Figure</u>		<u>Page</u>
1	Chemical structure of different luciferins	2
2	Genetic components of the biochemical reaction leading to light production in bacteria	8
3	Genes comprising the lux operon of various luminous bacterial species	10
4	The biochemical process of light production in bacteria	12
5	Quorum Sensing in <i>Vibrio harveyi</i>	15
6	Sequence analysis of the lux operon in D1 and D6	31
7	Phylogenetic analysis of <i>luxA</i> in bioluminescent bacteria	32
8	Phylogenetic analysis of <i>toxR</i> in bioluminescent bacteria	33
9	Phylogenetic analysis of multiple housekeeping genes in bioluminescent bacteria	34
10	Transcriptional regulation of light production in D1 and D6	35
11	Quorum sensing curves for D6 and D1	37
12	Copy number of the lux operon in D1 and D6	38
13	PCR amplification of each individual lux gene in D1 and D6	39

LIST OF TABLES

<u>Table</u>		<u>Page</u>
1	Shared nucleotide sequence identity in the lux genes of D1, D6, and <i>V. harveyi</i> B392	27
2	Shared nucleotide sequence identity in a set of genes highly conserved amongst bioluminescent bacteria	28
3	Shared amino acid sequence identity in the lux genes of D1, D6, and <i>V. harveyi</i> B392	29
4	Shared amino acid sequence identity in a set of genes highly conserved amongst bioluminescent bacteria	30

ACKNOWLEDGEMENTS

I would like to first and foremost thank my advisor, Dr. Chuck Wimpee, for his instruction, guidance, and friendship. I do not have the words to adequately express my gratitude for all you have done to not only help me complete this program but also to prepare for the future. I would also like to thank my committee members, Dr. Steven Forst and Dr. Sandra Mclellan for their thoughtful advice and critique of my research. I also want to thank Dr. Jennifer Gutzman for her advice and support during my time here. Thanks to my lab mates, past, present, and honorary: Chris Storlie (my other academic half), Liz Bolton, Katie Barry, Rachel Kinzelman, Nicole Thunes, Kristin Venkler, Mckenzie Pickett, Alexis Bury, and Addie Skillman. I also have to thank the rest of my fellow graduate students for their support in the form of conversation, often over tater tots and fermented beverages. Furthermore, I would like to thank the Department of Biological Sciences at the University of Wisconsin – Milwaukee for their investment in my education and their allowing me the opportunity to grow as a researcher in their exceptional graduate program.

I also have to thank my friends and family. To Ryan, this master's degree has been a journey and I thank you for your unending support, patience, and understanding throughout its entirety. You truly are the best buddy. I want to thank my sisters, Kristin and Allison, for their willingness to listen to me talk about my science regardless of their actual interest in the subject matter. I would also like to thank the rest of Allison's family. Thanks to my brother in law Allan for the interesting science-based conversations, I can always count on you for a unique and thought-provoking

perspective. And thanks to my niece Olive and nephew Ewan for the pure joy they bring to my life. And finally, I have to thank my father, Dennis. I literally couldn't have done this without you! I appreciate every single way that you have supported me over the years, and I acknowledge that they are numerous. I couldn't have asked for a more understanding and supportive father. From the bottom of my heart, thank you.

Introduction

Bioluminescence

Bioluminescence is the natural biochemical emission of light by any living organism. This phenomenon is widely distributed across the phylogenetic tree of life with representatives in more than 700 genera distributed amongst various microorganisms as well as fungi and animals. The vast majority are marine organisms, though there are terrestrial and freshwater representatives as well (Shimomura 2006). Approximately 90% of all organisms living at the ocean floor produce and/or are able to detect luminescence (Shimomura 2006), providing an obvious advantage to organisms living in an environment without access to sunlight.

The origin and evolution of bioluminescence remain elusive to this day, though it is generally accepted that bioluminescence has evolved multiple times and in many different living organisms based on the diversity seen in the structure of substrates, mechanisms, and functions of light production in different organisms. Luciferins are the substrates in the light-producing reaction that actually emit light (Wilson and Hastings 1998). The structure of luciferins varies greatly amongst bioluminescent organisms, with some being highly conserved across phyla. The most common luciferins are bacterial, dinoflagellate, coelenterazine, and cypridina (Fig. 1). While these substrates tend to be conserved, luciferases and other photoproteins are often less conserved and more likely to have been derived from a number of different evolutionary lineages. The striking difference in the structure of luciferins along with the multitude of different luciferases and photoproteins

lends support to the hypothesis that bioluminescence has originated and evolved independently multiple times.

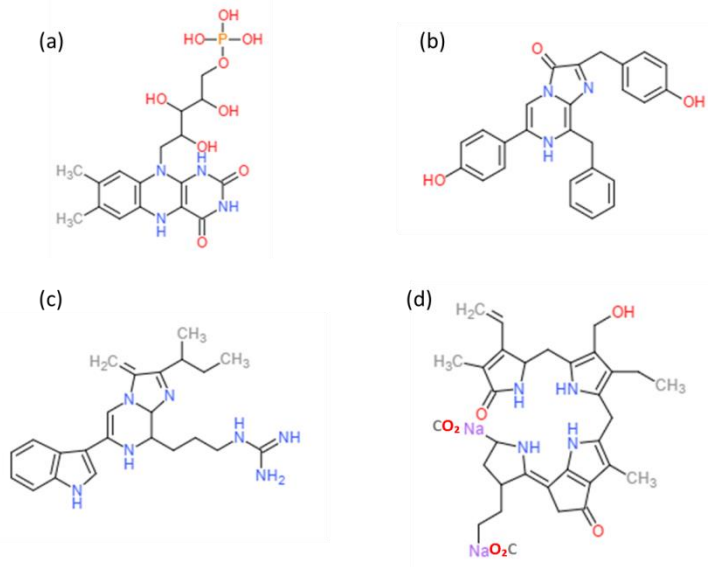

Figure 1. Chemical structure of different luciferins. The chemical structure of (a) bacterial (FMNH₂), (b) coelenterazine, (c) cypridina, and (d) dinoflagellate luciferins vary greatly.

The mechanisms by which organisms luminesce are also varied amongst bioluminescent representatives. In bacteria, it is the binding of luciferase to its respective luciferin (FMNH₂) in the presence of oxygen, and subsequent interaction with a nonspecific long chain aliphatic aldehyde that leads to the emission of light. In dinoflagellates, the luciferase is sensitive to pH. Exposure to a change in the concentration of hydrogen ions induces a conformational change in the luciferase which exposes the binding site for its luciferin (Schultz et al. 2005). Coelenterazine is used by many different bioluminescent organisms. This luciferin is synthesized from a tripeptide precursor made up of a phenylalanine and two tyrosine residues (Ward et al. 1994), though not all organisms that utilize coelenterazine are capable of synthesizing it (Haddock et al. 2001), and the exact mode of

biosynthesis is not well understood. The luciferin cypridina is synthesized from tryptophan, arginine, and isoleucine and has been linked to dietary intake (Warner & Case 1980) as some luminescent fish utilizing this particular luciferin are incapable of producing the necessary amino acids and must therefore obtain them via their diet. In some fish that utilize cypridina, the light organ is actually an extension of the digestive system (Sugiyama et al. 1961), illustrating the link between bioluminescence and dietary intake in these organisms.

Organisms produce light strategically and for many different reasons. In general terms, bioluminescence can be used as either an attractant, typically by use of a luminescent glow, or a deterrent, where luminescence is often in the form of a flash of light. A bright flash of light can be used to startle a predator, allowing the luminescent organism the opportunity to escape (Vallin et al. 2006, Haddock & Case 1994, Robinson et al. 2003).

Counterillumination is another defense mechanism with luminescence being used as a form of camouflage. These organisms possess photophores on their ventral surface capable of matching the intensity of light coming from the ocean surface, counteracting any shadow that may have been cast. This prevents the organism from being detected by any predators swimming below with upward facing eyes (Johnsen et al. 2004, Herring et al. 1992, Harper & Case, 1999). Bioluminescence is also used as a sort of burglar alarm where a flash of light is emitted in an effort to attract the attention of a predator of the bioluminescent organism's predator (Mensingher & Case 1992). Organisms can alternatively use bioluminescence as a means of attracting or illuminating prey (Pietsch 2009, Kubodera et al. 2007), increasing the chance of successful predation. Furthermore, intraspecies communication can be accomplished by use of bioluminescence and is often displayed in an

effort to attract a mate (Woods et al. 2007, Rivers & Morin 2008, Woodland et al. 2002, Ikejima et al. 2004).

There are several different hypotheses for the origin of bioluminescence. It was originally thought that proto-bioluminescence may have evolved from a protein containing fluorescent groups that was linked to the respiratory chain (Harvey, 1922). Luciferases have often been implicated as the point of origin for these light generating reactions. Luciferases may have evolved from an enzyme originally responsible for detoxifying molecular oxygen at the time of the Great Oxidation Event, allowing anaerobic organisms the opportunity to adapt to their changing environment (McElroy and Seliger 1962). Alternatively, early luciferases may have utilized oxygen as an electron acceptor, increasing the efficiency of and capacity for energy production (Seliger 1975). It is also possible that luciferases evolved from flavoprotein oxygenases capable of catabolizing saturated aldehydes at low oxygen pressures (Seliger 1987) or from oxygenases involved in the metabolism of various toxic substances (Seliger 1993). As bioluminescence almost certainly originated multiple times, the origin, purpose, and evolution therefore most likely vary across different bioluminescent organisms.

Bacterial bioluminescence

Bioluminescent bacteria are exclusive to the Gammaproteobacteria and within that class primarily found in the genera *Vibrio*, *Aliivibrio*, and *Photobacterium* of the family *Vibrionaceae*. There are also a select few luminous species found in the genera *Photorhabdus* and *Shewanella*, of the families *Enterobacteriaceae* and *Shewanellaceae*,

respectively (Urbanczyk and Dunlap 2013), those these represent bacterial species that were previously non-luminescent and gained the ability to make light by obtaining lux genes, the genes necessary for light production, via lateral gene transfer. This narrow distribution of bioluminescence amongst bacteria argues that this feature originated once within the bacteria in member of the *Vibrionaceae*, with subsequent loss and transfer of the genes necessary for light production. This is further supported by the fact that all bioluminescent bacteria utilize the same biochemical reaction to produce light (Fig. 2).

The vast majority of the bioluminescent bacteria are restricted to marine environments with the exception of *Vibrio cholerae*, which is capable of inhabiting brackish or fresh waters (Palmer and Colwell 1991), and luminous members of the genus *Photobacterium*, which are terrestrial organisms (Fischer-Le Saux et al. 1999). Marine bioluminescent bacteria can be isolated from seawater, sediment, suspended particulates (Baumann and Baumann 1981), inanimate surfaces, macroalgae (Makemson et al. 1992), or from marine animals they are colonizing (Baumann and Baumann 1981). They colonize these animals as saprophytes, commensal symbionts, or parasites (Baumann and Baumann 1981, Dunlap 2009). The incidence of these bacteria in seawater is quite low (0.01 – 40 cell/ml) but they can attain high numbers in the associations they form with animals (Neelson and Hastings 1992). Luminous bacteria show little specificity when forming opportunistic saprophytic or enteric associations with marine animals (Preheim et al. 2011) but in cases of bioluminescent symbiosis, are highly specific to a single species of bacteria (Woodland et al. 2002, Dunlap et al. 2009).

The function of bioluminescence in bacteria is not entirely clear. The fact that the process is conserved even though it is energetically expensive would suggest that it is essential to the organism's survival. Yet many species of the family *Vibrionaceae* are not luminescent and are not any less successful as a result (Baumann and Baumann 1981, Wollenberg et al. 2011). In cases of bioluminescent symbiosis the bacterial benefit is clear; the bacteria are being provided with nutrients and the O₂ necessary to produce light and in exchange are providing the host with luminescence, the display of which can be used to attract a mate, avoid a predator, or to help illuminate potential prey (Harvey 1952, Hastings and Nealson 1981). In cases of free-living bioluminescent bacteria the function is less clear. It is possible that the luminescence producing reaction could aid in reoxidation of reduced coenzymes under conditions of low oxygen, functioning as a secondary respiratory chain when the concentration of oxygen is too low for the cytoplasmic membrane-associated electron transport chain to function (Hastings and Nealson 1981, Nealson and Hastings 1992). This would allow the bacteria to survive in environments like the fish intestine, a preferred habitat due to its rich nutrient content. It is also possible that bioluminescence is used as a means of dispersing the bacteria. In this case, bacteria form a luminous colony on some particle of decaying tissue or a fecal pellet which is detected by an animal that is attracted to the light. The bacteria are eaten by the animal, which brings the bacteria into the animal's nutrient rich gut, within which the bacteria are able to reproduce. The bacteria will eventually be passed out of the animal's digestive system, aiding in the dispersal of the bacteria (Hastings and Nealson 1981, Nealson and Hastings 1992). As bioluminescence appears to provide no selective advantage to free living bacteria, it is possible that

whatever function it previously carried out is no longer necessary for survival and is consequently in the process of being lost all together.

The lux operon

Common to all bioluminescent bacterial species is the lux operon, a core set of genes necessary for light production. At a minimum, the lux operon is made up of *luxCDABE* with most species also containing a number of different accessory genes (Ast and Dunlap 2004, Urbanczyk et al. 2007)(Fig. 3). The genes *luxA* and *luxB* code for the α and β subunits of the enzyme luciferase, which is the catalyst of the biochemical reaction producing bacterial bioluminescence, while *luxC*, *luxD*, and *luxE* code for the r (reductase), s (synthetase), and t (transferase) polypeptides of the fatty acid reductase complex, respectively. This fatty acid reductase complex provides the cell with the reduced long chain aliphatic aldehyde substrate necessary for the reaction to occur. The required FMNH₂ is produced by a flavin reductase complex coded for by *luxG*, a common accessory gene of the lux operon (Meighen and Dunlap 1993, Lin et al 1998, Nijvipakul et al. 2008) (Fig. 2).

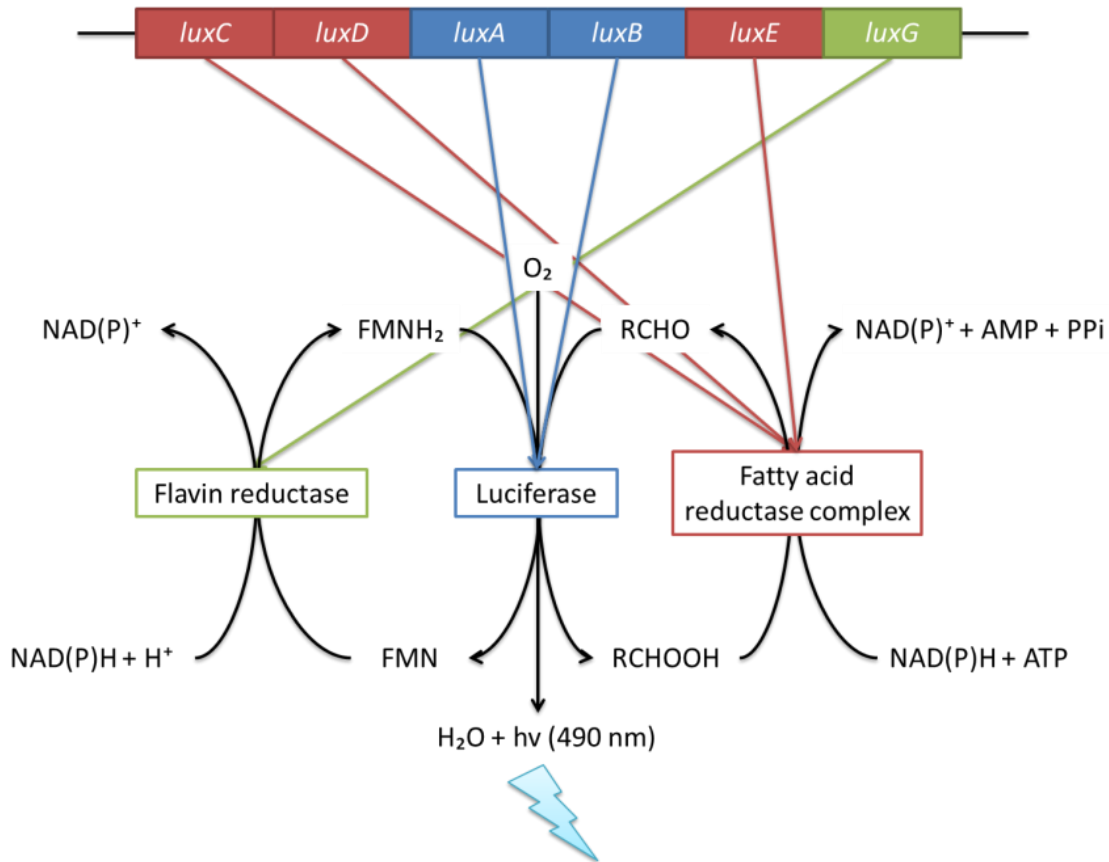

Figure 2. Genetic components of the biochemical reaction leading to light production in bacteria. The proteins necessary for biochemical reaction that causes bioluminescence in bacteria are coded for by a group of genes called the lux operon. A flavin reductase (coded for by *luxG*) provides the bacteria with a supply of FMNH₂. A fatty acid reductase complex (coded for by *luxC*, *luxD*, and *luxE*) is responsible for the synthesis and recycling of RCHO, a necessary aldehyde substrate. Luciferase (coded for by *luxA* and *luxB*) catalyzes the oxidation of reduced FMNH₂ and RCHO by use of O₂, emitting a blue green light ($\lambda = 490 \text{ nm}$) in the process.

The lux operon in luminous species of the genus *Aliivibrio* also contains *luxR* and *luxI*, genes coding for regulatory proteins involved in mediating the expression of the lux genes (Engebrecht et al. 1983, Schaefer et al. 1996). This is also the case in *Shewanella hanedai*, which, based on sequence similarity and gene arrangement, appears to have obtained its lux operon via lateral transfer of the lux genes from a member of the genus *Aliivibrio* (Kasai et al. 2007, Urbanczyk et al. 2008). These genes are typically not seen as a part of the lux

operon, though *luxR*, or some homologue, is present within the genome of all bioluminescent bacteria (Dunlap and Urbanczyk 2013). All luminous members of the genus *Photobacterium*, with the exception of *P. leiognathi*, contain *luxF*, which codes for a non-fluorescent flavoprotein (Ast and Dunlap 2004). The *luxF* gene is the result of a gene duplication event of *luxB*. The respective LuxF protein may function by scavenging for an inhibitory side product of the luminescence reaction but is not necessary for light production (Moore and James 1995, Kaeding et al. 2007). Also found in representatives of *Photobacterium* are genes involved in the synthesis of riboflavin, in an organized group of genes termed the rib operon (*ribEBHA*), though *P. phosphoreum* lacks *ribE* (Lee et al. 1994, Lin et al. 2001). These two operons are under the control of the same regulatory elements and together form the lux-rib operon. *Vibrio* species *harveyi* and *campbellii* also contain *luxH*, a homologue of *ribB* (Swartzman et al. 1990). Since there is a copy of *ribB* elsewhere in the genome, it is not clear whether there is an advantage to this redundancy, especially considering that many bioluminescent bacteria lack *luxH* as part of the lux operon, and instead rely on the single copy of *ribB*.

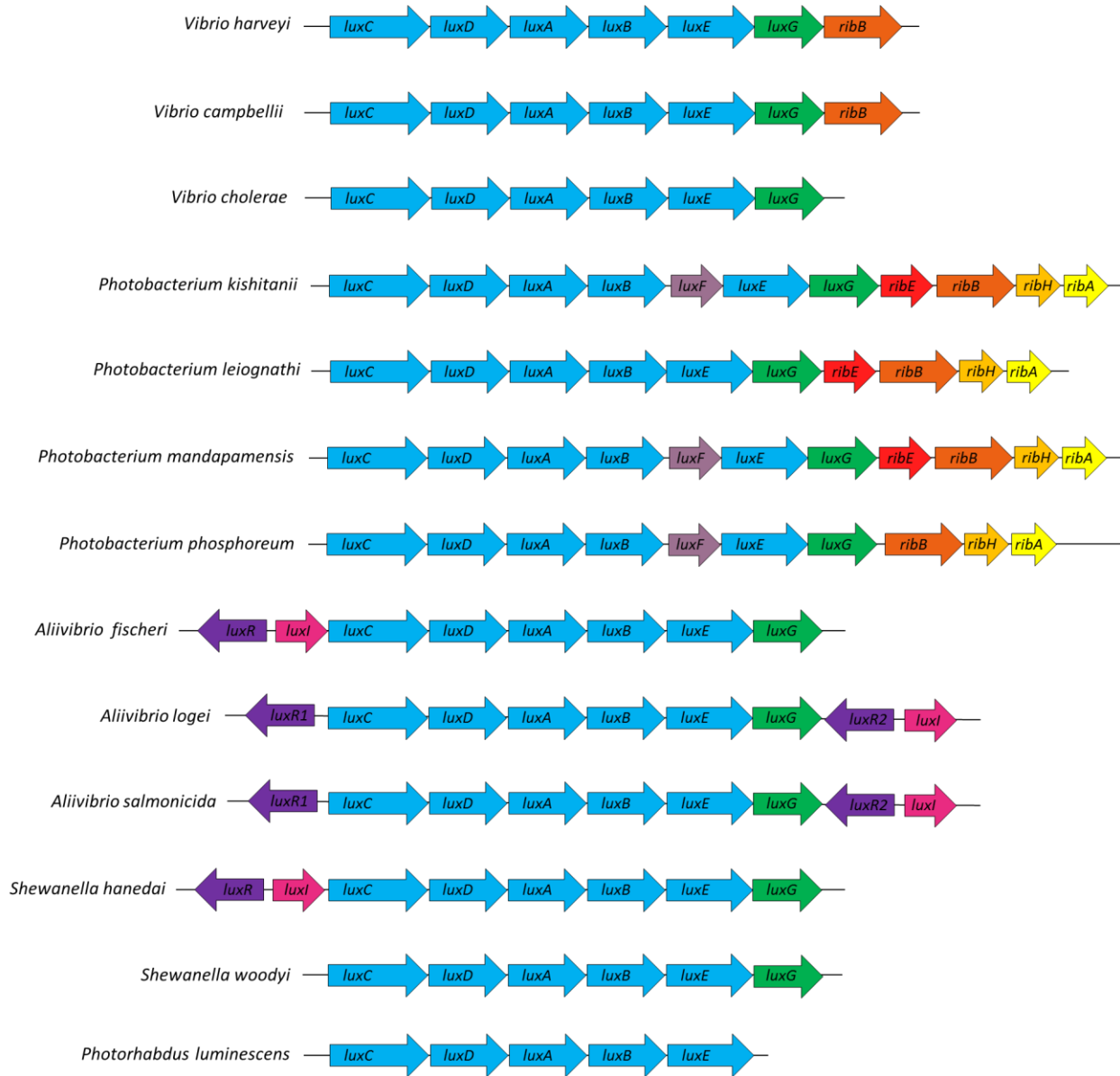

Figure 3. Genes comprising the lux operon of various luminous bacterial species. The core genes of the lux operon (*luxCDABE*) are shown in light blue. Various other accessory genes are depicted in different colors. The direction of transcription of each gene is depicted by the direction of the arrow on which it is shown. (Adapted from Dunlap and Urbanczyk 2013)

Inheritance of the lux genes is said to be primarily vertical, though there are well documented cases of laterally transferred lux operons (Ast et al. 2007, Urbanczyk et al. 2008). As mentioned before, based on a high degree of sequence identity and similar gene arrangement *S. hanedai* is thought to have received its operon via lateral transfer from a member of the genus *Aliivibrio* (Kasai et al. 2007). *S. woodyi* also seems to have been the recipient of lux genes transferred laterally from a species of *Aliivibrio* (Kasai et al. 2007). Phylogenetic analysis has added further support to both of these hypotheses (Urbanczyk et al. 2008). The lux operon in *Photorhabdus luminescens* was thought to have been acquired from an ancestor of *V. harveyi* (Forst et al. 1997, Meighen 1999) but phylogenetic analysis has not been definitive in this case (Urbanczyk et al. 2008). There are also documented cases of lateral transfer of lux genes amongst species of the genus *Vibrio*. *V. chagasii* was the recipient of the lux operon of *V. harveyi* (Urbanczyk et al. 2008), as was a luminous strain of *V. vulnificus* (Oliver et al. 1986). Though we know of all of these cases of lateral gene transfer of the lux operon, there has only previously been one reported case of the lateral replacement of the lux operon in any bioluminescent bacterial species, in a strain of *Photobacterium aquimaris* (Urbanczyk et al. 2012).

Biochemistry of bacterial bioluminescence

As stated before, the biochemistry of bioluminescence varies amongst different organisms. It is however, conserved within the bacteria. The biochemical reaction responsible for light production in bacteria is catalyzed by the enzyme, luciferase. Luciferase is a heterodimeric

protein made up of α and β subunits. Luciferase is responsible for mediating the oxidation of two substrates, a nonspecific long chain aliphatic aldehyde (RCHO) and a reduced flavin mononucleotide (FMNH₂), which emits a photon in the process (Fig. 4). The oxidant is O₂, yielding H₂O.

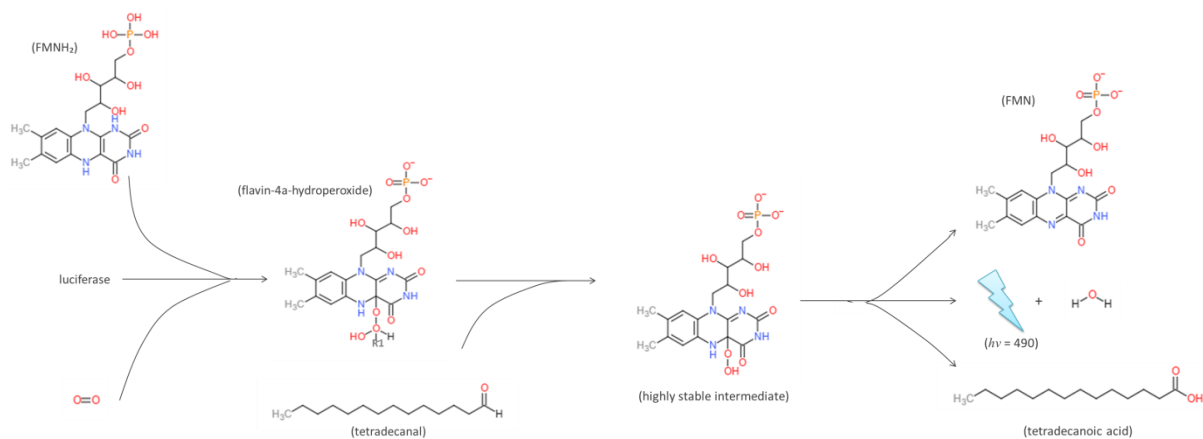

Figure 4. The biochemical process of light production in bacteria. The biochemical reaction leading to light production in bacteria begins with the binding of luciferase to FMNH₂ and subsequent interaction with O₂ to form flavin-4a-hydroperoxide. Flavin-4a-hydroperoxide interacts with a long chain aldehyde substrate to form a highly stable intermediate which, over a process of slow decay, oxidizes FMNH₂ and RCHO to form FMN and RCOOH, emitting light in the process. (Adapted from Ripp et al., 2011)

This reaction begins with the binding of FMNH₂ to luciferase. This complex can then interact with O₂ to form flavin-4a-hydroperoxide. The flavin-4a-hydroperoxide interacts with the RCHO to form a highly stable intermediate. This highly stable intermediate undergoes a process of slow decay, emitting a blue-green light ($h\nu = 490$ nm) in the process, as well as oxidizing both substrates to produce FMN and RCOOH (Fig. 4). In this reaction, FMNH₂ is supplied by flavin reductase, an NAD(P)H-flavin oxido-reductase enzyme (Fig. 4). The long chain aliphatic aldehyde is provided by a fatty acid reductase complex made up of three polypeptides, an NADPH-dependent acyl protein reductase, an

acyl transferase, and an ATP-dependent synthetase. The reaction is highly specific for FMNH₂ but not so for the long chain aliphatic aldehyde, though its presence in some form is necessary and has been shown to most often be tetradecanal *in vivo* (Lee et al. 1990, Meighen and Dunlap 1993, Hastings 1995, Wilson and Hastings 1998).

Transcriptional regulation of the lux operon in bacteria

Light production is an energetically expensive process and thus needs to be under tight regulation. In bacteria, this is accomplished by quorum sensing. Quorum sensing provides bacteria with the means to regulate gene expression in response to fluctuations in the cell density of their immediate surroundings. Bacteria synthesize auto-inducer molecules that can be sensed by receptor proteins present at their inner membrane. These receptor proteins can then relay that signal to other proteins within the cell that can carry out some function in response. While the exact mechanisms of quorum sensing vary, they all follow this general outline.

In *V. harveyi* and its close relatives, there are three different auto-inducer molecules involved in the regulation of light production by quorum sensing: 3-hydroxybutanoyl-HSL (*harveyi* autoinducer-1, HAI-1) which is specific to *V. harveyi* and other closely related species, (2S,4S)-2-methyl-2,3,3,4-tetrahydroxytetrahydrofuran borate (*V. harveyi* autoinducer-2, AI-2_{Vh}) which is an interspecies communicator capable of being both synthesized and detected by many different species of bacteria, and (S)-3-hydroxytridecan-4-one (*cholerae* autoinducer, CAI-1) which has been shown to be present in both *V. cholerae* as well as *V. harveyi*, though its use outside of the genus *Vibrio* is currently

unknown. Synthesis of HAI-1, AI-2_{vh}, and CAI-1 are carried out by LuxM, LuxS, and CqsA, respectively (Cao and Meighen 1989, Bassler et al. 1993, Schauder et al. 2001, Kelly et al. 2009). Each of these auto-inducer molecules has a corresponding histidine kinase receptor protein located at the inner plasma membrane. HAI-1 binds LuxN, AI-2_{vh} binds LuxPQ, and CAI-1 binds CqsS (Bassler et al. 1993, Bassler et al. 1994a, Henke and Bassler 2004). Under conditions of low auto-inducer concentration, LuxN, LuxPQ, and CqsS act as kinases, phosphorylating the phosphotransfer protein, LuxU. LuxU passes the phosphate to LuxO, a DNA response regulator (Bassler et al. 1994b, Bassler 1999, Lilley and Bassler 2000). Phosphorylated LuxO, along with the sigma factor σ^{54} , then activates transcription of several small regulatory RNAs (Qrr 1-5) (Lenz et al. 2004, Tu and Bassler 2007). These small regulatory RNAs bind the *luxR* transcript, destabilizing it. LuxR is responsible for activating transcription of the *lux* operon and so by destabilizing the *luxR* message, transcription of the *lux* genes is blocked (Showalter et al. 1990, Swartzman et al. 1992)(Fig. 5a). Under conditions of high concentration of auto-inducer molecules, the receptor kinase proteins switch their activity to that of a phosphatase, leading to dephosphorylation of LuxO. Dephosphorylated LuxO is no longer able to activate transcription of the small regulatory RNAs Qrr 1-5. Without those small regulatory RNAs binding the *luxR* transcript, the message is translated and LuxR is produced and able to activate transcription of the *lux* operon. This system has the added complexity of a negative autoregulation of LuxR and LuxO, as well as the post transcriptional control of LuxO by Qrr 1,5 (Fig. 5b). These additional regulatory mechanisms allow for the fine tuning of light production in response to the various environmental changes the bacterium may encounter (Waters and Bassler 2005, Tu et al. 2010).

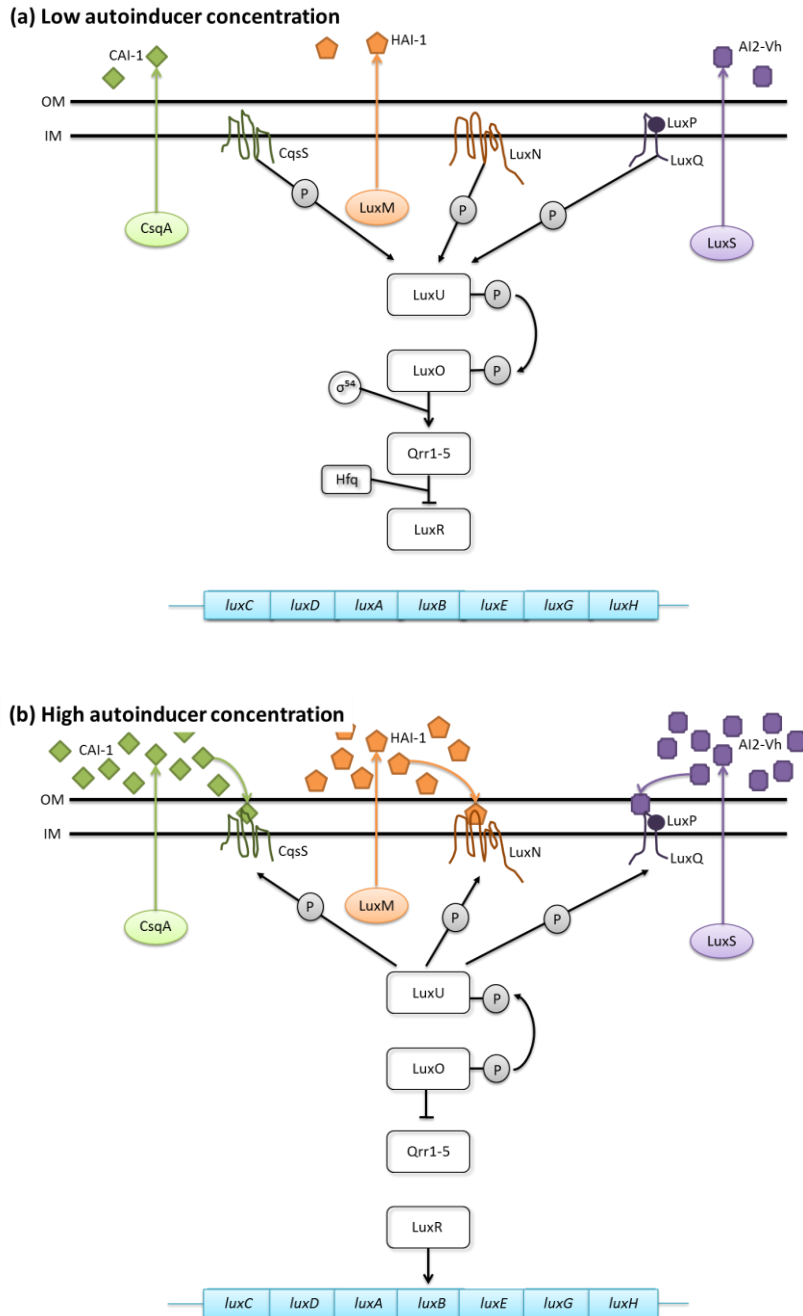

Figure 5. Quorum Sensing in *Vibrio harveyi*. (a) At low autoinducer concentration, receptor proteins act as kinases, phosphorylating LuxU. LuxU in turn phosphorylates LuxO which, along with σ^{54} , activates expression of genes coding for the small regulatory RNAs, Qrr1-5. Qrr1-5 then act with the small RNA chaperone, Hfq, to bind and block transcription of *luxR*. Without LuxR, the *lux* operon is not transcribed. (b) At high autoinducer concentration, autoinducers bind their receptors which act as phosphatases. These phosphatases dephosphorylate LuxO which interrupts transcription of the small regulatory RNAs Qrr1-5. In the absence of these small regulatory RNAs, *luxR* is transcribed and therefore LuxR is able to activate transcription of the *lux* operon leading to the production of light. (Adapted from Bassler, 2006)

Hypothesis

In a screening of bioluminescent bacteria isolated from the intestines of coral reef fish, an isolate termed D6 was identified that has a *luxA* gene sequence significantly divergent from those of other *Vibrio* species (O'Grady 2008). This led to the development of two hypotheses: (1) either D6 represents a separate lineage, as of yet undescribed or (2) D6 is of a known lineage but has acquired its lux operon via lateral gene transfer from an unknown donor. Furthermore, if this is in fact a case of lateral gene transfer, D6 either contains or has lost its ancestral copy of the lux operon.

This study investigates the means by which D6 obtained its lux operon. To test this, I will compare sequence and phylogenetic analysis of nucleotide sequence of the lux operon as well as a selection of highly conserved genes unrelated to light production in D6 with its close relatives, D1 and *V. harveyi*. I will examine conservation of regulatory elements in D6 and D1 by testing cross-species activation of the lux operon in both strains using the transcriptional activator, LuxR, from *V. harveyi*. Finally, I will determine copy number of the lux operon in both D6 and D1. Sequence and phylogenetic divergence in lux genes with concurrent similarity in other conserved genes will indicate a lateral transfer of the lux operon in D6. Cross-species activation of the lux operon in D6 will add further support for a lateral gene transfer event. A single copy of the lux operon in D6 will indicate a lateral replacement of its ancestral operon with the lux operon it currently possesses.

Methods and Materials

Bacterial Strains

Bacterial strains D1 and D6 were isolated at the same place and time from the intestine of a coral reef fish off of Chub Cay, an island in the Bahamas. A lab strain of *V. harveyi* (B392) was used as a positive control. *E. coli* JM109 cells were obtained from Promega. *V. harveyi* as well as strains D1 and D6 were maintained in SWC + 30% glycerol at -80°C. *E. coli* JM109 cells were maintained in LB + 30% glycerol at -80°C.

Media

Bacterial strains D1, D6 and *V. harveyi* were grown on Sea Water Complete (SWC) growth medium [per liter: 375 ml Artificial Sea Water (per liter: 58.44g NaCl, 10.15g MgCl₂, 12.3g MgSO₄·7H₂O, 1.49g KCl), 5g tryptone, 3g yeast extract, 3ml glycerol, 622ml dH₂O] either with aeration in liquid media or on plates (by adding 15g/L agar to SWC) at room temperature (25°C).

E. coli JM109 cells were grown on Luria Bertani (LB) growth medium (per liter: 10g tryptone, 5g yeast extract, 10g NaCl) either with aeration in liquid media or on plates (by adding 15g/L agar to LB) at 37°C. For induction of the luxR_{Vh} expression system, LB containing 0.2% arabinose, 25µg/ml chloramphenicol, and 100µg/ml ampicillin was used.

During bacterial transformation, NZY medium (per liter: 5g NaCl, 2g MgSO₄·7H₂O, 5g yeast extract, 10g NZ amine) was used for cell recovery.

Gel electrophoresis and imaging

Nucleic acid electrophoresis gels were made using 1% agarose dissolved in 1X TAE buffer (0.04M Tris-acetate, 0.001M EDTA) with an added 1 μ g/ml ethidium bromide. A 1kb ladder was used for size comparison of DNA fragments. Gels were photographed using a Kodak Gel Logic 100 imaging system.

Imaging of bioluminescent bacterial colonies was done using GeneSnap 7.12. The settings were as follows: 5 minute exposure, high resolution, no filter, and no light.

Polymerase chain reaction

A set of existing *V. harveyi* primers was used to obtain portions of the nucleotide sequence of the lux operon and flanking regions in D1. From the obtained sequences, additional primers were designed to fill in any gaps. Consensus primers were designed using sequence from various *Vibrio* species in order to amplify the USORF, *luxC*, and *moeAB* in D1 as well as USORF and *moeB* in D6 and *luxR* from D1, D6, and *V. harveyi*.

Amplification of DNA fragments was done via polymerase chain reaction (PCR) using GoTaq polymerase (Promega) for amplification of short fragments (<2000 bp) and Phusion polymerase (ThermoFisher) for amplification of long fragments (>2000 bp). The reactions were carried out using a Bio-Rad DNA Engine Thermal Cycler. PCR products were verified via gel electrophoresis and subsequently purified using the QIAquick spin column purification system.

Sequence analysis

Sequencing of amplified DNA fragments was done by Sanger Sequencing at the University of Chicago's DNA Sequencing Center. DNA sequence assembly was done using Basic Local Alignment Search Tool (BLAST) via NCBI. Upon completion of the sequencing of the operon and flanking regions in D1, restriction digests were done looking for fragments of predicted size to confirm DNA sequence obtained was correct.

The lux operon and flanking regions of D6 were obtained by cloning and subsequent sequencing of clones. Genomic DNA from D6 was digested with Sau3A and run through gel electrophoresis overnight at 20V. Bands of DNA approximately 20 kb in size were excised and purified using the QIAEX II Agarose Extraction kit per the manufacturer's protocol. A plasmid pGEM3Z was digested with BamHI and subsequently dephosphorylated using Thermosensitive Alkaline Phosphatase (TSAP). The DNA fragments were then ligated into the plasmid and transformed into competent *E. coli* XL10 Gold cells. Blue-white screening was used to confirm successful insertion of the plasmid. Colony hybridization using a *luxA* probe was used to identify lux-containing clones. The chosen colonies were then grown up overnight in LB + ampicillin at 37°C for isolation of plasmid DNA. Plasmid DNA was isolated from the overnight cultures using the Wizard Plus SV Miniprep DNA Purification system per the manufacturer's protocol. The insert DNA was then sequenced and assembled.

Phylogenetic analysis

All phylogenetic analysis was carried out using MEGA7 (Kumar et al. 2015). The evolutionary history in the multilocus tree was inferred by using the Maximum Likelihood method based on the General Time Reversible model (Nei and Kumar 2000). The tree with the highest log likelihood is shown. The percentage of trees in which the associated taxa clustered together is shown next to the branches. Initial tree(s) for the heuristic search were obtained automatically by applying Neighbor-Join and BioNJ algorithms to a matrix of pairwise distances estimated using the Maximum Composite Likelihood (MCL) approach, and then selecting the topology with superior log likelihood value. A discrete Gamma distribution was used to model evolutionary rate differences among sites. The rate variation model allowed for some sites to be evolutionarily invariable. The tree is drawn to scale, with branch lengths measured in the number of substitutions per site. The analysis involved 19 nucleotide sequences. All positions with less than 95% site coverage were eliminated. That is, fewer than 5% alignment gaps, missing data, and ambiguous bases were allowed at any position.

The evolutionary history in both the *ftsZ* and *mreB* nucleotide trees was inferred by using the Maximum Likelihood method based on the Kimura 2-parameter model (Kimura 1980). The trees with the highest log likelihood are shown. The percentage of trees in which the associated taxa clustered together is shown next to the branches. Initial tree(s) for the heuristic search were obtained automatically by applying Neighbor-Join and BioNJ algorithms to a matrix of pairwise distances estimated using the Maximum Composite Likelihood (MCL) approach, and then selecting the topology with superior log likelihood

value. A discrete Gamma distribution was used to model evolutionary rate differences among sites. The trees are drawn to scale, with branch lengths measured in the number of substitutions per site. The analyses involved 19 nucleotide sequences. All positions with less than 95% site coverage were eliminated. That is, fewer than 5% alignment gaps, missing data, and ambiguous bases were allowed at any position.

The evolutionary history in the *luxA* and *topA* nucleotide trees was inferred by using the Maximum Likelihood method based on the Tamura-Nei model (Tamura and Nei 1993). The trees with the highest log likelihood are shown. The percentage of trees in which the associated taxa clustered together is shown next to the branches. Initial tree(s) for the heuristic search were obtained automatically by applying Neighbor-Join and BioNJ algorithms to a matrix of pairwise distances estimated using the Maximum Composite Likelihood (MCL) approach, and then selecting the topology with superior log likelihood value. A discrete Gamma distribution was used to model evolutionary rate differences among sites. The trees are drawn to scale, with branch lengths measured in the number of substitutions per site. The analyses involved 16 and 19 nucleotide sequences for analysis of *luxA* and *topA*, respectively. All positions with less than 95% site coverage were eliminated. That is, fewer than 5% alignment gaps, missing data, and ambiguous bases were allowed at any position.

The evolutionary history in the *ftsZ* and *mreB* amino acid trees was inferred by using the Maximum Likelihood method based on the General Reversible Chloroplast model (Adachi et al. 2000). The trees with the highest log likelihood are shown. The percentage of trees in which the associated taxa clustered together is shown next to the branches. Initial tree(s)

for the heuristic search were obtained automatically by applying Neighbor-Join and BioNJ algorithms to a matrix of pairwise distances estimated using a JTT model, and then selecting the topology with superior log likelihood value. The trees are drawn to scale, with branch lengths measured in the number of substitutions per site. The analyses involved 19 amino acid sequences. All positions with less than 95% site coverage were eliminated. That is, fewer than 5% alignment gaps, missing data, and ambiguous bases were allowed at any position.

The evolutionary history in the *ftsZ* and *topA* amino acid trees was inferred by using the Maximum Likelihood method based on the Le_Gascuel_2008 model (Le and Gascuel 2008). The trees with the highest log likelihood are shown. The percentage of trees in which the associated taxa clustered together is shown next to the branches. Initial tree(s) for the heuristic search were obtained automatically by applying Neighbor-Join and BioNJ algorithms to a matrix of pairwise distances estimated using a JTT model, and then selecting the topology with superior log likelihood value. The rate variation model allowed for some sites to be evolutionarily invariable. The trees are drawn to scale, with branch lengths measured in the number of substitutions per site. The analyses involved 16 amino acid sequences. All positions with less than 95% site coverage were eliminated. That is, fewer than 5% alignment gaps, missing data, and ambiguous bases were allowed at any position.

The evolutionary history in the *toxR* amino acid tree was inferred by using the Maximum Likelihood method based on the JTT matrix-based model (Jones et al. 1992). The tree with the highest log likelihood is shown. The percentage of trees in which the associated taxa

clustered together is shown next to the branches. Initial tree(s) for the heuristic search were obtained automatically by applying Neighbor-Join and BioNJ algorithms to a matrix of pairwise distances estimated using a JTT model, and then selecting the topology with superior log likelihood value. The tree is drawn to scale, with branch lengths measured in the number of substitutions per site. The analysis involved 22 amino acid sequences. All positions with less than 95% site coverage were eliminated. That is, fewer than 5% alignment gaps, missing data, and ambiguous bases were allowed at any position.

Cloning of the lux operon from strain D1

DNA spanning from the USORF to moeB in D1 was amplified using phosphorylated primers for use as an insert into plasmid pGEM-3Z. pGEM-3Z was digested using SmaI with digestion being verified via gel electrophoresis. The digested plasmid was then dephosphorylated using Thermosensitive Alkaline Phosphatase (TSAP). The insert was then ligated into the dephosphorylated plasmid and transformed into competent *E. coli* JM109 cells. Blue-white screening was used to confirm successful insertion. White colonies were chosen and colony PCR performed using primers specific to SP6 and T7 from pGEM-3Z. Gel electrophoresis was used to verify an insert of expected size. The chosen colonies were then grown up overnight in LB + ampicillin at 37°C for isolation of plasmid DNA. Plasmid DNA was isolated from the overnight cultures using the Wizard Plus SV Miniprep DNA Purification system per the manufacturer's protocol. Purified plasmid DNA was then digested separately with EcoRI and PstI to verify the generation of bands of predicted size based on known nucleotide sequence.

Dual plasmid arabinose-inducible LuxR_{VH} system

The purified plasmid DNA was then transformed into competent *E. coli* JM109 cells containing an arabinose inducible plasmid construct with the *V. harveyi luxR* sequence as the insert. Previously purified plasmid DNA containing the lux operon from D6 and from *V. harveyi* were also transformed in *E. coli* JM109 cells. The cells were plated onto LB + ampicillin + chloramphenicol (+/- arabinose) and grown overnight at 37°C. The plates were photographed as described previously using the GeneSnap 7.12 program.

Quorum sensing assays

Each bacterial strain (D1, D6, and *V. harveyi* B392) was inoculated from a freezer stock into 25 ml of SWC broth and grown overnight at 25°C on a shaker plate set at approximately 180 rpm for to keep the cultures aerated. The cultures were then diluted back 1 ml into 50 ml in SWC broth and kept at 25°C on a shaker plate set at 18 rpm for the remainder of the experiment. At time zero and each hour thereafter, an aliquot was removed from each culture and measured for optical density at 600nm using BioPhotometer plus and light output using Lumac Biocounter M 2010. The data generated was used to created growth and light curves which when overlaid, give an approximation of the cell density at which light production is activated via quorum sensing. Growth and light curves were generated using the Microsoft Office program, Excel. The entire procedure was repeated 3 times.

Southern hybridization

Verification of copy number of the lux operon in D6 was done by southern hybridization. Genomic DNA from D1 and D6 was digested using the restriction enzymes DraI, Eco4711, and SnaBI. Predicted band sizes were calculated using Webcutter 2.0. The digests were run through gel electrophoresis overnight at 20V. The gel was then depurinated in 0.25N HCl, denatured in 0.5N NaOH + 1.5M NaCl, and neutralized in 1M Tris-HCl (pH 7.5) + 1.5M NaCl. The DNA was then transferred to a nylon membrane by capillary blot in 20 x SSC (3M NaCl + 0.3M Na citrate). DNA was then fixed to the membrane by UV crosslinker and placed in pre-hybridization buffer (formamide, 20 x SSC, 50 x Denhardt's, 2ml 10mg/ml yeast RNA, 3 ml H₂O) overnight. The membrane was then moved to hybridization buffer, which contains everything the pre-hybridization has plus the addition of a P³² labeled probe. The probes used were made from the *luxA* sequences of D1 and D6. The membrane was then washed and exposed to X-ray film. This result was confirmed by PCR amplification of each individual lux gene in D1 and D6 using consensus primers designed using sequence from both D1 and D6.

Results

Sequence analysis

In order to identify the species of bioluminescent isolates D1 and D6, a group of housekeeping genes, along with other highly conserved genes, and the lux genes were sequenced and compared to sequences available in GenBank, as well as each other, using BLAST. Comparative analysis of the nucleotide sequence of the lux genes from D6 with those of D1 showed that they share in the range of 76 – 91% identity depending on the particular gene, and 86% identity across the entire lux operon (Table 1). These results were nearly identical for D6 compared with *V. harveyi* B392 (Table 1). These results are in stark contrast with those from a comparative sequence analysis of housekeeping genes, flanking genes, and *toxR* which show a high percentage of shared identity amongst all three bacterial strains (Table 2). The same trends in sequence identity were observed in comparison of amino acid sequences (Tables 3 & 4). The gene coding for the regulator of bioluminescence in bacteria, *luxR*, was also shown to share a high sequence identity amongst all three strains, though D1 and D6 shared a higher identity with each other (99%) as compared to both D1 and D6 with *V. harveyi* B392 (93%) (Tables 2 & 4). The fact that D6 only significantly differs only in the sequence of its lux genes and not in that of any other conserved genes is indicative of a lateral gene transfer of the lux operon in D6.

Organism	Gene	Organism		
		D1	D6	<i>V. harveyi</i> B392
		% identity	% identity	% identity
D1	<i>luxC</i>	—	82	94
	<i>luxD</i>	—	87	96
	<i>luxA</i>	—	87	97
	<i>luxB</i>	—	91	99
	<i>luxE</i>	—	87	97
	<i>luxG</i>	—	83	96
	<i>luxH</i>	—	76	96
	lux operon	—	86	96
D6	<i>luxC</i>	82	—	81
	<i>luxD</i>	87	—	88
	<i>luxA</i>	87	—	87
	<i>luxB</i>	91	—	90
	<i>luxE</i>	87	—	86
	<i>luxG</i>	83	—	83
	<i>luxH</i>	76	—	76
	lux operon	86	—	86
<i>V. harveyi</i> B392	<i>luxC</i>	94	81	—
	<i>luxD</i>	96	88	—
	<i>luxA</i>	97	87	—
	<i>luxB</i>	99	90	—
	<i>luxE</i>	97	86	—
	<i>luxG</i>	96	83	—
	<i>luxH</i>	96	76	—
	lux operon	96	86	—

Table 1. Shared nucleotide sequence identity in the lux genes of D1, D6, and *V. harveyi* B392. Nucleotide sequence of the lux genes in D6 was shown to be significantly divergent from that of both D1 and *V. harveyi* B392.

Organism	Gene	Organism		
		D1	D6	<i>V. harveyi</i> B392
		% identity	% identity	% identity
D1	<i>luxR</i>	—	99	93
	USORF	—	96	85
	<i>moeB</i>	—	90	98
	<i>toxR</i>	—	97	75
	<i>ftsZ</i>	—	99	95
	<i>mreB</i>	—	97	94
	<i>topA</i>	—	98	91
D6	<i>luxR</i>	99	—	93
	USORF	96	—	81
	<i>moeB</i>	90	—	91
	<i>toxR</i>	97	—	75
	<i>ftsZ</i>	99	—	95
	<i>mreB</i>	97	—	94
	<i>topA</i>	98	—	90
<i>V. harveyi</i> B392	<i>luxR</i>	93	93	—
	USORF	85	81	—
	<i>moeB</i>	98	91	—
	<i>toxR</i>	75	75	—
	<i>ftsZ</i>	95	95	—
	<i>mreB</i>	94	94	—
	<i>topA</i>	91	90	—

Table 2. Shared nucleotide sequence identity in a set of genes highly conserved amongst bioluminescent bacteria. Nucleotide sequence of all conserved genes, other than the *lux* genes, in D6 was shown to be highly similar to those of D1 and *V. harveyi* B392. While closely related to both, D6 appears to be somewhat more closely related to D1 than to *V. harveyi* B392.

Organism	Gene	Organism		
		D1	D6	<i>V. harveyi</i> B392
		% identity	% identity	% identity
D1	<i>luxC</i>	—	80	96
	<i>luxD</i>	—	92	98
	<i>luxA</i>	—	95	99
	<i>luxB</i>	—	91	98
	<i>luxE</i>	—	89	98
	<i>luxG</i>	—	86	97
	<i>luxH</i>	—	81	99
	lux operon	—	87	91
D6	<i>luxC</i>	80	—	85
	<i>luxD</i>	92	—	94
	<i>luxA</i>	95	—	94
	<i>luxB</i>	91	—	91
	<i>luxE</i>	89	—	88
	<i>luxG</i>	86	—	85
	<i>luxH</i>	81	—	81
	lux operon	87	—	88
<i>V. harveyi</i> B392	<i>luxC</i>	96	85	—
	<i>luxD</i>	98	94	—
	<i>luxA</i>	99	94	—
	<i>luxB</i>	98	91	—
	<i>luxE</i>	98	88	—
	<i>luxG</i>	97	85	—
	<i>luxH</i>	99	81	—
	lux operon	91	88	—

Table 3. Shared amino acid sequence identity in the lux genes of D1, D6, and *V. harveyi* B392. Similar to nucleotide sequence (Table 1), the amino acid sequence of D6 was shown to be significantly divergent from that of both D1 and *V. harveyi* B392.

Organism	Gene	Organism		
		D1	D6	<i>V. harveyi</i> B392
		% identity	% identity	% identity
D1	<i>luxR</i>	—	100	100
	USORF	—	99	93
	<i>moeB</i>	—	95	99
	<i>toxR</i>	—	99	77
	<i>ftsZ</i>	—	100	99
	<i>mreB</i>	—	100	99
	<i>topA</i>	—	100	97
D6	<i>luxR</i>	100	—	100
	USORF	99	—	93
	<i>moeB</i>	95	—	96
	<i>toxR</i>	99	—	77
	<i>ftsZ</i>	100	—	99
	<i>mreB</i>	100	—	99
	<i>topA</i>	100	—	97
<i>V. harveyi</i> B392	<i>luxR</i>	100	100	—
	USORF	93	93	—
	<i>moeB</i>	99	96	—
	<i>toxR</i>	77	77	—
	<i>ftsZ</i>	99	99	—
	<i>mreB</i>	99	99	—
	<i>topA</i>	97	97	—

Table 4. Shared amino acid sequence identity in a set of genes highly conserved amongst bioluminescent bacteria. As with the nucleotide sequence analysis, analysis of the amino acid sequence of several highly conserved genes shows D6 being closely related to both D1 and *V. harveyi* B392. D6 again appears to be somewhat more closely related to D1 than to *V. harveyi* B392.

The gene arrangement of the flanking regions in D6 was also found to be different than that of D1 and *V. harveyi* B392 (Fig. 6). D1 and *V. harveyi* B392 share the conserved arrangement of a highly conserved unidentified open reading frame upstream of the lux operon (USORF) and *moeAB* at the 3' end of the lux operon. In contrast, the lux operon in D6 is flanked on the 5' end by a transposase gene and on the 3' end by *parA* (Fig. 6). This is

a gene arrangement not before seen in the flanking regions of a lux operon, indicating this is not the ancestral location of the lux operon and thus lends further support to the hypothesis that D6 obtained its lux operon by means of lateral gene transfer.

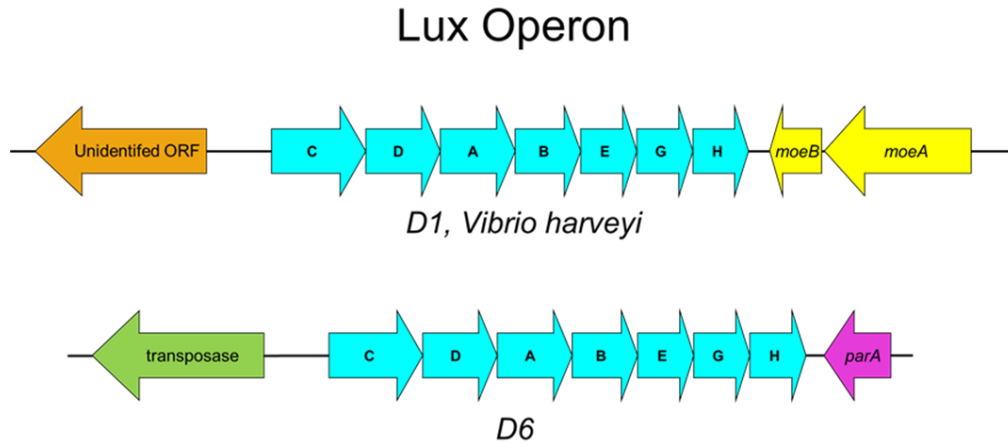

Figure 6. Sequence analysis of the lux operon in D1 and D6. Sequence analysis revealed that while D1 and D6 share the highly conserved *luxCDABEGH* arrangement of lux genes found in *V. harveyi*, they share only an 86% identity at the nucleotide level. Furthermore, the lux operons of D1 and D6 have completely different flanking regions. D6 was shown to contain both the upstream unidentified ORF and *moeAB* found in D1 and *V. harveyi*, though not in an arrangement previously seen in any *Vibrio* species.

D6 has been shown to contain both *moeB* and the conserved USORF, and while they share a relatively high identity with D1 and *V. harveyi* B392 (Tables 2 & 4), they are not present in a gene arrangement that allows them to be amplified in the same PCR, as was done with D1.

Phylogenetic analysis

Phylogenetic analyses of *luxA* and of the sequenced housekeeping and other conserved genes was done to determine evolutionary relationship of D1 and D6. The analysis of *toxR*, *ftsZ*, *mreB*, and *topA* show D6 and D1 falling within the same clade (Figs. 8 & 9) whereas

phylogenetic analysis of *luxA*, a representative gene of the lux operon, shows D6 appearing in a clade separate from D1 and others like it (Fig. 7). As was shown with the sequence analysis (Tables 1-4), the distinct difference between phylogenetic grouping of D6 relative to D1 and *V. harveyi* B392 suggests that D6 is actually a close relative of D1 and *V. harveyi* and that D6 has obtained its lux operon via lateral gene transfer from some unknown donor.

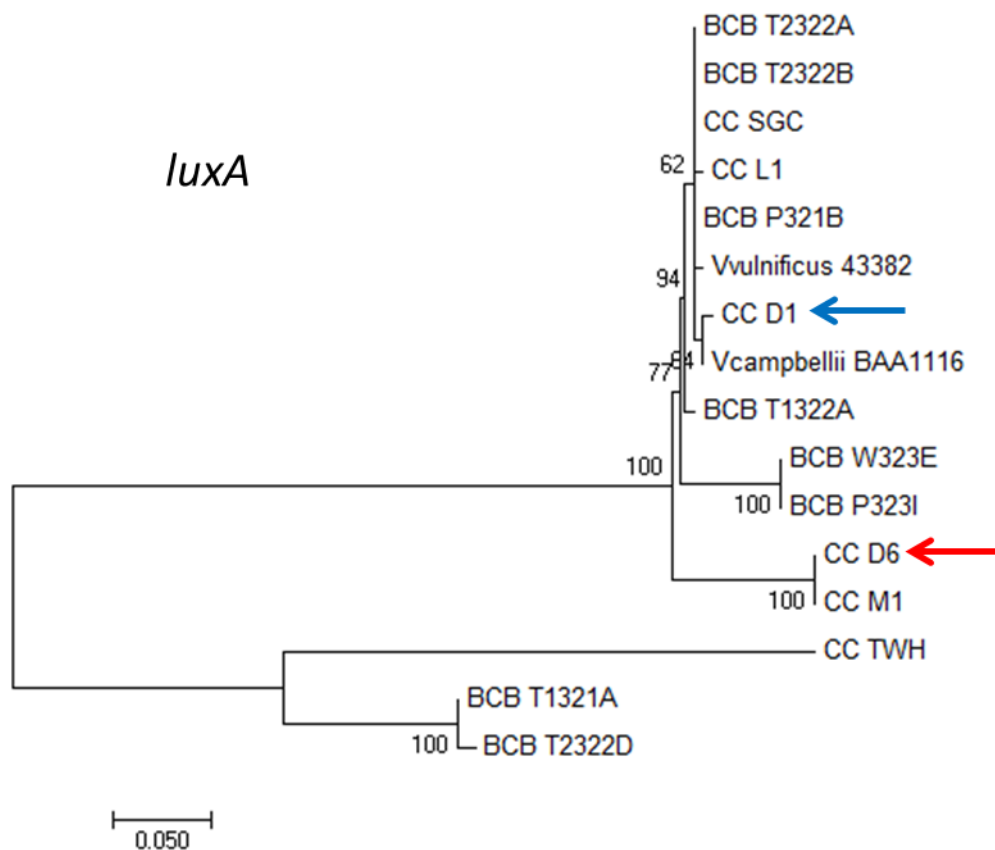

Figure 7. Phylogenetic analysis of *luxA* in bioluminescent bacteria. Analysis of a gene representative of the lux operon, *luxA*, shows that strain D6 (and a nearly identical strain, M1), are significantly divergent from other bioluminescent bacteria included in the analysis.

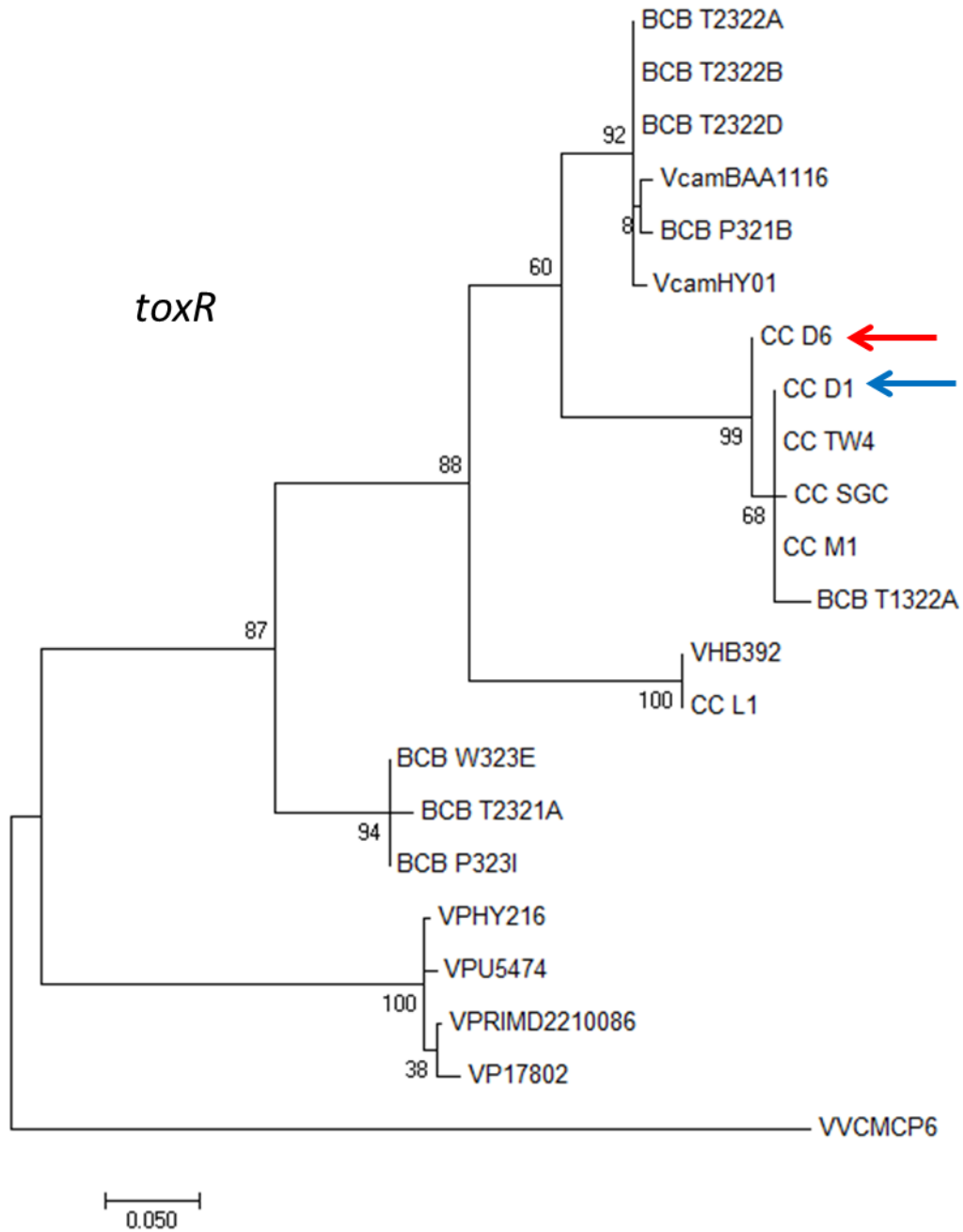

Figure 8. Phylogenetic analysis of *toxR* in bioluminescent bacteria. Analysis of *toxR*, a gene highly conserved amongst bioluminescent bacteria, shows that D6 is closely related to D1 and other members of the D1 group.

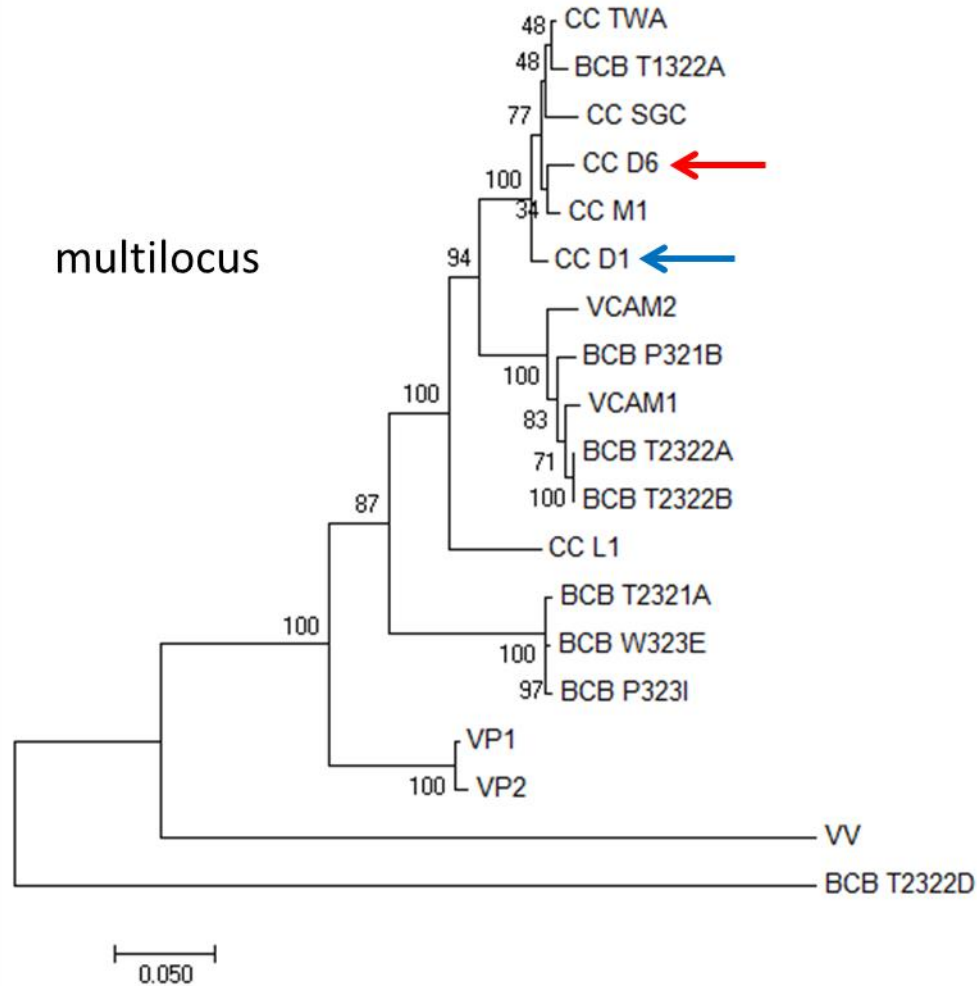

Figure 9. Phylogenetic analysis of multiple housekeeping genes in bioluminescent bacteria. Analysis done using concatenated housekeeping sequences (*ftsZ*, *mreB*, and *topA*) from bioluminescent bacteria shows that D6 is closely related to D1 and other members of the D1 group.

Transcriptional regulation of the lux operon

In order to determine if the regulatory elements of the lux operon in D1 and D6 were conserved, as would be expected of strains closely related to *V. harveyi*, a cross species induction of the lux operon was done in both D1 and D6, using LuxR from *V. harveyi* (Fig. 10a). *E. coli* cells containing plasmids carrying *luxR* from *V. harveyi* and the lux operon from D1 and D6 both produced light upon induction with arabinose (Fig. 10b). This lends further

support to the hypothesis that D6 is closely related to both D1 and *V. harveyi*, with the exception of its lux genes, which again lends support to a lateral gene transfer of the lux genes in D6.

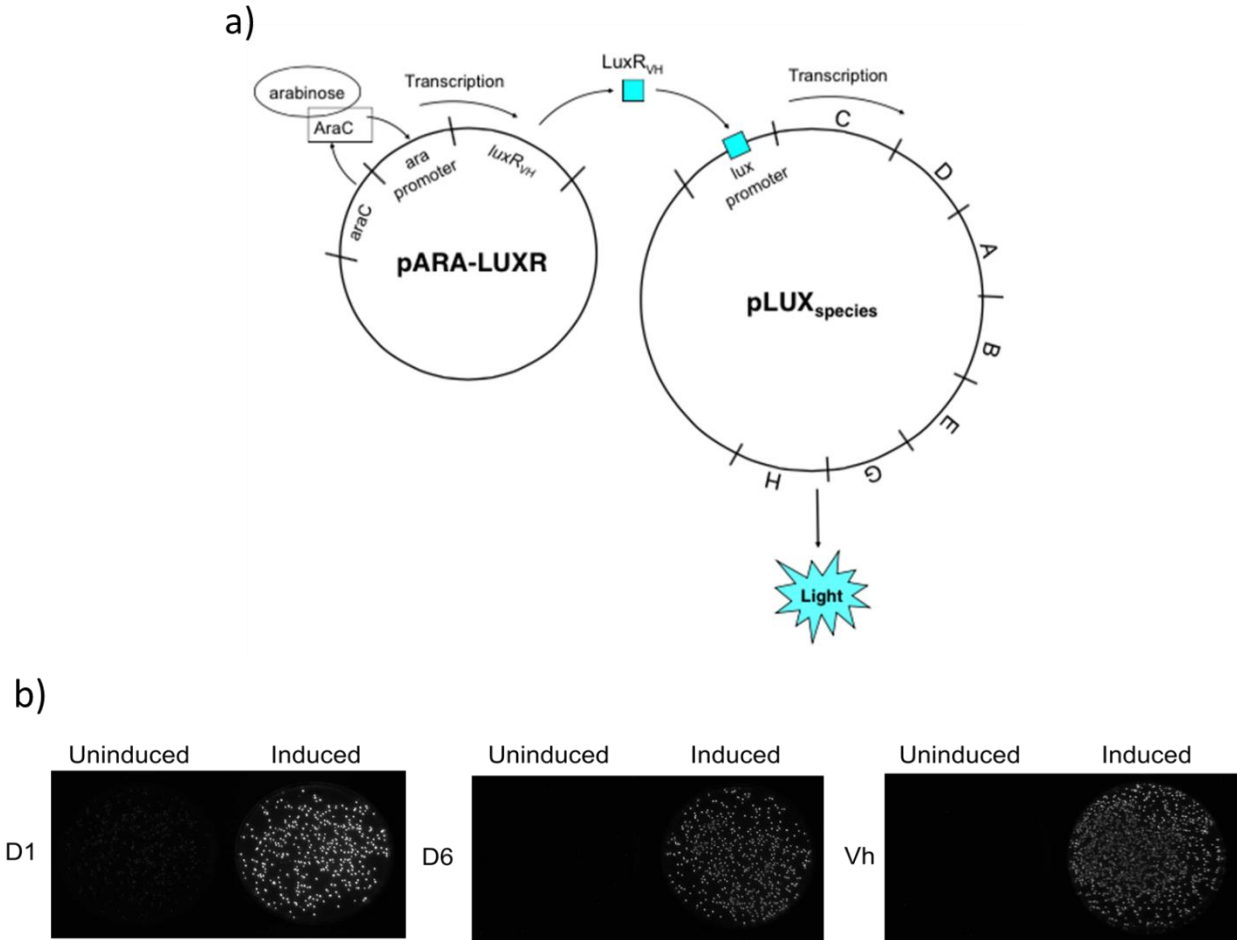

Figure 10. Transcriptional regulation of light production in D1 and D6. (a) Transcriptional regulation of the lux operon in D1 and D6 was examined using a dual plasmid arabinose-inducible LuxR system. Here, the luxR from *V. harveyi* was inserted into one plasmid containing an ara promoter (Wannamaker M.S. Thesis, 2013). This plasmid was then transformed into E.coli cells along with a second plasmid containing the lux operon of each strain (D1 and D6). (b) These cells were plated on selective media, grown overnight, and observed for light production. Light production was observed on the plates with arabinose present. This demonstrates the ability of LuxR protein from *V. harveyi* to activate transcription of the lux operon in both D1 and D6.

Quorum Sensing

In order to determine whether or not D1 and D6 use quorum sensing to regulate bioluminescence, light production and growth were simultaneously measured. Graphs were generated showing the relationship of cell density to light production. In both D1 and D6 it was shown that production of light did not begin until the cell density reached a certain threshold, inferred by an increase in optical density (Fig. 11). This suggests that D1 and D6 utilize the cell density-dependent regulatory mechanism of quorum sensing to regulate bioluminescence.

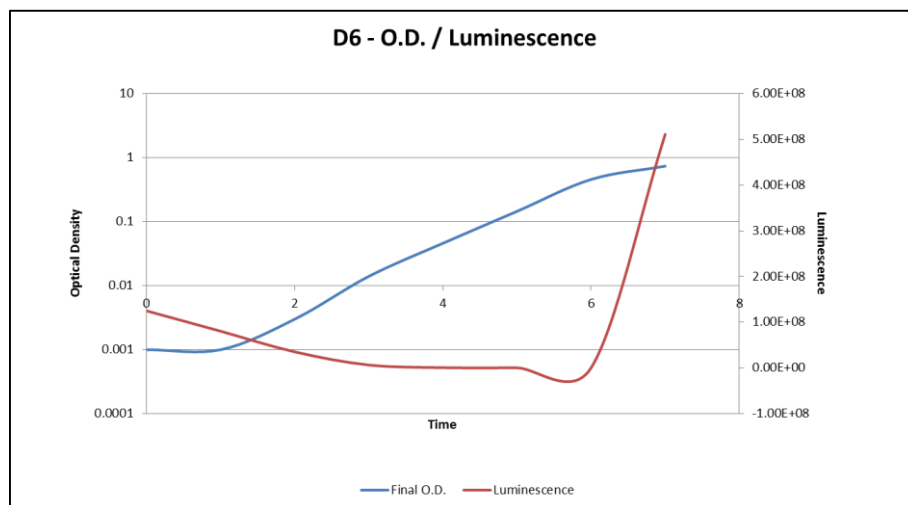
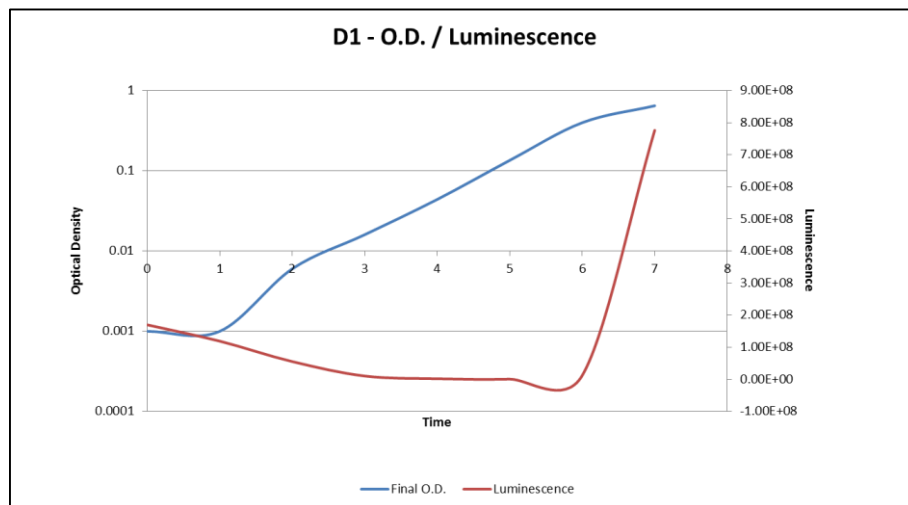
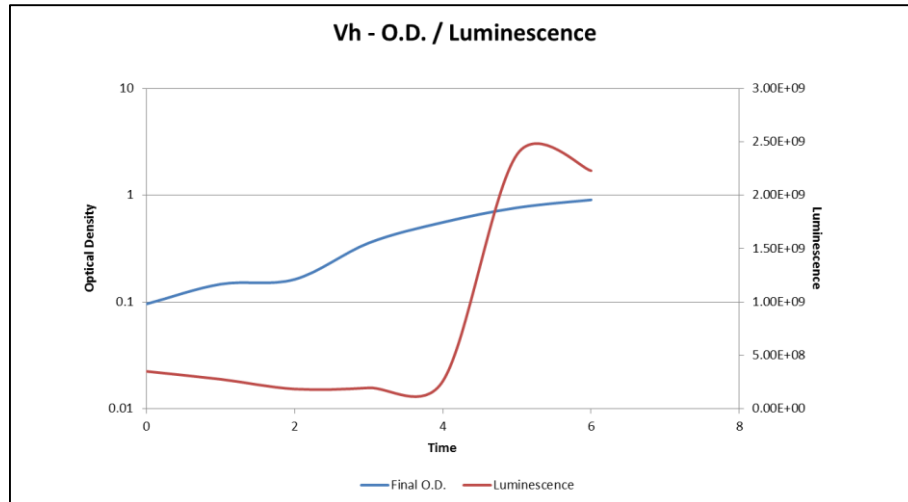

Figure 11. Quorum sensing curves for D6 and D1. The overlay of cell density with luminescence for both D1 and D6 show that production of luminescence does not occur until cell density increases. *V. harveyi* was used as a control and shows the expected pattern of an organism utilizing quorum sensing.

Copy number of the lux operon

Southern hybridization was used to determine copy number of the lux operon in D1 and D6. Southern hybridization of digested D6 DNA with a *luxA* probes made from the *luxA* sequence of D1 and a second probe made from the *luxA* sequence of D6 both generated a single signal (Fig. 12). Similarly, when the same probes were used on DNA from D1, a single signal was also observed and importantly, it generated the same banding pattern (Fig. 12) indicating that both probes are hybridizing to the same *luxA* sequence and as opposed to a second copy of *luxA*. A stronger signal was observed for each strain when the probe made with that strain's *luxA* sequence was used, showing that the *luxA* probes are more readily hybridized to the *luxA* sequence of the strain from which they were derived. The fact that there is a single hybridizing band in each digest strongly argues that there is one copy of the lux operon present in D6 and D1.

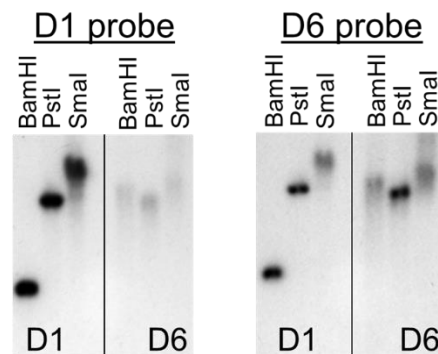

Figure 12. Copy number of the lux operon in D1 and D6. Genomic DNA from strains D1 and D6 was digested using *DraI*, *Eco47II*, and *SnaBI*. DNA fragments were separated using gel electrophoresis. A southern hybridization was done using a probe made from the *luxA* gene from D6. DNA from strains D1 and D6 was hybridized with this probe. A single signal was observed for each digest in both D1 and D6.

This result was confirmed via PCR amplification using primers targeting each individual lux gene of D1 and D6 with perfect sequence identity. Each reaction yielded a single band in both D1 and D6 (Fig. 13). When these DNA fragments were sequenced, each was shown to be a single nucleotide sequence, with no double peaks appearing in the chromatograms (data not shown).

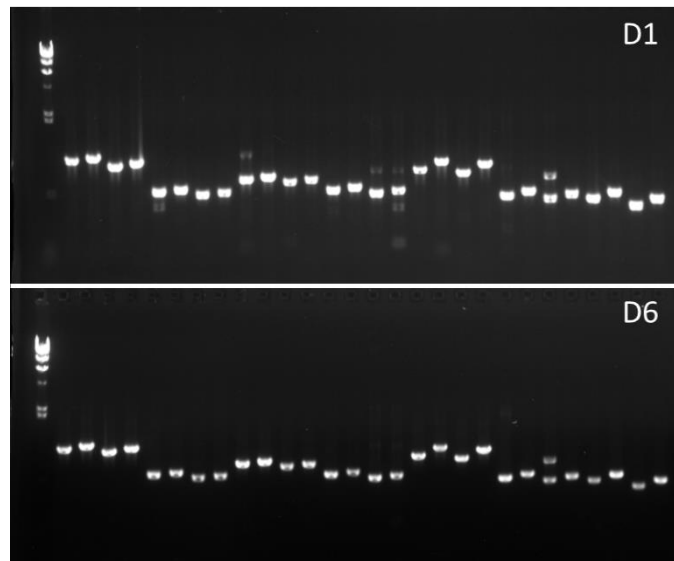

Figure 13. PCR amplification of each individual lux gene in D1 and D6. Each individual lux gene was amplified by use of consensus primers designed from nucleotide sequence of D1 and D6. Each reaction yielded a single band. When amplified and sequenced, no mixed sites were seen, indicating a single copy of each lux gene in both D1 and D6.

Discussion

Lateral transfer of the lux operon in D6

Comparative analysis of both nucleotide and amino acid sequences from D6 and other members of the genus *Vibrio* has revealed that while D6 is highly divergent in terms of its lux genes, all other genes sequenced from D6 are highly similar to D1 and *V. harveyi*. This suggests that D6 does not represent a separate lineage of bioluminescent bacteria but rather represents a bacterial strain highly similar to both D1 and *V. harveyi* that has acquired its lux operon via lateral gene transfer from an unknown donor.

The hypothesis of lateral gene transfer of the lux operon in D6 was further investigated by means of phylogenetic analysis, determination of gene arrangement of the lux operon and its flanking regions, exploration of the transcriptional regulation of the lux operon, and examination of the quorum sensing mechanism. Phylogenetic analysis of *luxA*, a representative gene of the lux operon, shows D1 in a clade with other members of the D1 group as well as close relatives *V. harveyi* and *V. campbellii* while D6 is in a completely separate clade shared with only M1, an isolate nearly identical to D6 (Fig. 7). This is in stark contrast to the phylogenetic trees constructed using *toxR* (Fig. 8) or any of the sequenced housekeeping genes (Fig. 9) which show D6 in the same clade as D1. The fact that D6 and D1 are similar in all of the highly conserved sequences compared argues that D6 and D1 are closely related, with D6 being part of the group of isolates designated the D1 group. Because the lux genes in D6 do not follow this pattern and are instead highly divergent from D1 and its close relatives suggests that this lux operon is not ancestral to D6 and instead was obtained via lateral gene transfer.

This lateral gene transfer hypothesis was further supported by the discovered gene arrangement of the flanking regions of the lux operon in D6. Both D1 and *V. harveyi* share the conserved arrangement of *moeAB* in the 3' flanking region of the lux operon and a conserved open reading frame (USORF) in the 5' flanking region (Fig. 6). D6, however, displays a previously undescribed gene arrangement in the flanking regions of its lux operon, being flanked by a transposase gene at the 5' end and *parA* at the 3' end (Fig. 6). This difference in gene arrangement between D6 and its close relatives suggests that the lux operon in D6 is not in the ancestral location within the genome, further supporting the lateral gene transfer hypothesis. These flanking genes also offer possible insight into the means by which D6 acquired this lux operon. The *parA* gene flanking the 3' end of the lux operon is homologous to a transcriptional regulator from lambda phage, responsible for maintaining latency and thus allowing propagation of phage genes (Dodd et al. 2001, Lewis et al. 2011), suggesting the lux operon in D6 may have been transferred in via transduction. There is also, however, a *parA* homologue present in the *V. harveyi* genome that is responsible for chromosomal partitioning (Travers et al. 2012, Shikorski et al. 2013). Because there is only a small amount of *parA* sequence available from D6, it is not possible to definitively say whether this particular *parA* gene is an ancestral to the bacterial genome or if it was transferred in with other phage genes during a transduction event. The transposase flanking the 5' end of the lux operon in D6 offers another possible scenario. It is possible that this transposase is part of a composite transposon carrying the lux operon within a mobile genetic element. Because there is a limited amount of sequence downstream of the lux operon in D6, it is not possible to confidently determine if this is the

case, as the remaining sequence that would make up the mobile genetic element cannot be detected.

The transcriptional regulator of the lux operon, LuxR, is known to be conserved amongst closely related bioluminescent bacterial species. It was shown that the *luxR* sequence of D6 is nearly identical to that of D1 and similar but distinct from *V. harveyi*, again suggesting that D6 is more closely related to D1 and likely part of the D1 group. The similarity in sequence of *luxR* also suggests that the respective DNA binding elements are also conserved. Investigation of these transcriptional regulatory elements of the lux operon in D6 was carried out by use of a dual plasmid expression system carrying the *luxR* sequence from *V. harveyi* on an arabinose-inducible plasmid and a second plasmid containing the lux operon of D6, and in a separate experiment, D1. This experiment showed that transcription of the lux operon in D6, as well as D1, is capable of being activated by the LuxR protein from *V. harveyi* (Fig. 10). This is in agreement with other studies done demonstrating the conservation of these regulatory elements amongst close relatives of *V. harveyi* (Wannamaker 2013). This further emphasizes that D6 is similar to D1 and *V. harveyi* with the exception of its lux genes, again suggesting the lux genes in D6 were obtained via lateral gene transfer. Not surprisingly, D6 and D1 were both also shown to utilize quorum sensing in the transcriptional control of light production (Fig. 11). The exact quorum sensing mechanism in D6 and D1 was not determined in this study but would likely be similar to that of *V. harveyi*, given the other demonstrated similarities between these two isolates and *V. harveyi*.

Lateral replacement of the ancestral lux operon in D6

Because all known members of the D1 group are luminescent and thus contain a lux operon (data not shown), it is likely that D6 either contains or at one point contained but has subsequently lost its ancestral lux operon. It was therefore necessary to determine the copy number of the lux operon in D6. It was shown both by southern hybridization (Fig. 12) and PCR amplification (Fig. 13) that there is a single copy of the lux operon in D6. This suggests that the lateral transfer of the lux operon in D6 was actually a replacement event of its ancestral lux genes.

The D1 group of bioluminescent bacteria

Through this research the emergence of a new group of bioluminescent bacteria, designated the D1 group, became evident. This group is made up of D1, D6, several other Chub Cay isolates (M1, BW1, E1, MarA, TWA, TW4, BWD, TW10, and E2), and an isolate from Boca Ciega Bay (T1322A). Based on both sequence (Tables 2 & 4) and phylogenetic analysis (Figs. 8 & 9), this group was shown to be similar to but distinct from *V. harveyi* and likely represents a previously undescribed bioluminescent bacterial species that is within the *V. harveyi* group.

This discovery of not only a previously undescribed bioluminescent bacterial species but an entire group of this new species illustrates the fact that we are still accumulating knowledge of the diversity amongst bioluminescent bacteria. As sequencing technology improves, the resolution with which we are able to differentiate small differences between closely related species also improves. The D1 group is not the only recently described new

species of luminous bacteria; there have been several described over the last few years, such as *Aliivibrio sifiae* (Yoshizawa et al. 2010a), *Photobacterium aquimaris* (Yoshizawa et al. 2009b) *Vibrio azureus* (Yoshizawa et al. 2009a), *Vibrio beijerinckii* (Figge et al. 2011), *Vibrio sagamiensis* (Yoshizawa et al. 2010b), as well as a newly discovered *Aliivibrio* species (Whyte and Wimpee 2016). Sequence analysis of bioluminescent symbionts present in the light organs of various deep sea fish have revealed a new genus within the family *Vibrionaceae*, termed *Candidatus Photodesmus* (Haygood 1993, Hendry and Dunlap 2011). These bacteria are obligate symbionts and thus unable to live outside their host, making culturing them in the lab impossible. It is only due to the new sequencing technologies available that this new bioluminescent bacterial genus was able to be described. There are also bacterial strains that produce light in their natural habitat but not when grown in laboratory conditions (Nealson and Hastings 1979, Silverman et al. 1989, Nealson and Hastings 1992). There may therefore be more bacterial species that are naturally bioluminescent but due to the lack of light production when grown in laboratory conditions, have gone undiscovered. This suggests that as more bacterial genomes are sequenced, there will be an increase in our collective knowledge and understanding of bioluminescent bacterial diversity.

Implications of lateral gene transfer in bacterial evolution

The lux operon offers a convenient phenotype for the study of lateral gene transfer amongst bacteria, as it is readily visible, but the lux operon is hardly the sole example of lateral gene transfer in bacteria. Lateral transfer of genes is important as it can drive the

evolution of the recipient cell in a much more dramatic way than is possible with vertical genetic transfer alone (Feder 2007, Boto 2010). That being said, the process is not uncomplicated and simply transferring a gene to a new cell does not guarantee the gene will be propagated. In order to have successful lateral transfer of genes, the gene(s) in question need to be transferred into the genome in such a way that they do not disrupt an essential gene, native to the recipient cell. The laterally transferred gene then needs to be maintained in order to be propagated in future generations of the recipient bacterial cell, which typically occurs only if the newly acquired gene imparts a function for which there is a selective advantage. Furthermore, if the laterally transferred gene is dependent upon other genes for proper function the transfer of that single gene may have a lesser impact than that of an entire operon (Lercher and Pál 2008, Price et al. 2008) which contains all the genes necessary to carry out the desired cellular function.

Whereas point mutations observed in vertical gene transfer can modify the function of an existing gene, laterally acquired genes can impart a completely novel function onto the recipient cell (Feder 2007). If this newly acquired gene provides the recipient cell with a selective advantage, it will outcompete those cells that did not acquire the new gene, thus improving the overall fitness of the recipient cell. Instances such as this can change the evolutionary trajectory of different bacterial species.

The extent to which lateral gene transfer is actually impacting the evolution of bacterial species is still debated, as researchers do not necessarily agree on the relative incidence of lateral gene transfer amongst bacteria (Kurland et al. 2003, Boucher et al. 2003).

Regardless of the incidence of lateral gene transfer, it is undeniable that it does have some

impact on the evolution of bacterial species. One such example of the impact of lateral gene transfer is antibiotic resistance. As the use of antibiotics increases in human medicine, horticulture, and treatment of livestock, so does the selective pressure on the spread of antibiotic resistance genes (Blair et al. 2015). Transfer of these antibiotic resistance genes allows for the recipient to thrive in an otherwise toxic environment. The simple fact that the recipient cell is now able to survive has allowed for the continued evolution of that particular bacterial cell.

Given that the selective pressure on newly acquired genes is what typically drives the maintenance and propagation of said genes, the lateral transfer of the lux operon offers an interesting and somewhat contradictory example of successful lateral gene transfer. It has been shown that presence of lux genes and subsequent ability to produce light is a nonessential function in bacteria, as there are currently more nonluminous species in the family Vibrionaceae than there are luminous species (Baumann and Baumann 1981, Dunlap and Ast 2005) and these nonluminous members do not appear to be any less successful than their luminescent counterparts (Baumann and Baumann 1981, Wollenberg et al. 2011). The fact that bioluminescent bacteria maintain their lux genes is especially intriguing given that light production is an energetically expensive process (Dunlap and Urbanczyk 2013). There are several schools of thought as to why bacteria produce light. It is possible that bacterial cells produce light to increase the probability of being ingested by light-attracted fish, so that they might access their nutrient-rich gut (Widder 2010; Zarubin et al, 2012). It is also possible that the lux operon once served an essential function (e.g. redox balance) that is no longer necessary and as such has no deleterious effect if lost.

Nonetheless, this contradiction, and our ignorance as to the reason behind it, highlights the fact that there is more yet to learn in regards to bioluminescence in bacteria.

Conclusion

The work presented in this thesis describes a case of lateral replacement of the lux operon in a bioluminescent bacterial isolate. Lateral transfer of the lux operon is said to be rare (Urbanczyk et al. 2008) and the few reported cases have predominantly been of the transfer of lux genes to previously non-luminescent bacterial species, such as *Shewanella hanedai* and *Photorhabdus luminescens* (Forst et al. 1997, Meighen 1999, Kasai et al. 2007, Urbanczyk et al. 2008). There is in fact only one other reported case of the lateral replacement of the lux operon in a bioluminescent bacterial species (Urbanczyk et al. 2012), making this a very rare event.

While reported cases of lateral transfer and/or replacement of the lux operon are few, it is possible that there are a greater number of these events that have gone undetected, because of the manner in which we typically study bioluminescent bacterial diversity. Our approach is to visually identify luminous colonies, then amplify and sequence the *luxA* gene. The strains that demand closer scrutiny are those with aberrant *luxA* sequences. Housekeeping genes or other highly conserved genes are not typically sequenced unless there is something about the *luxA* sequence that would indicate that particular isolate begged further examination, such as a divergent nucleotide sequence. It is therefore possible that there are cases of lateral gene transfer and/or replacement of the lux operon that have gone unnoticed because their *luxA* sequence was of a known bioluminescent bacterial species, whether or not it is the sequence that is ancestral to that particular isolate. Future work in this area should focus on identifying bacterial isolates based not only on their *luxA* sequence but also on that of some other highly conserved gene(s),

unrelated to bioluminescence. Such an approach would provide a means for detecting lateral gene transfer events in other bioluminescent isolates.

References

- Adachi J, Waddell PJ, Martin W, Hasegawa M (2000) Plastid genome phylogeny and a model of amino acid substitution for proteins encoded by chloroplast DNA. *J. Molecular Evolution* 50:348-358
- Ast JC, Dunlap PV (2004) Phylogenetic analysis of the lux operon distinguishes two evolutionarily distinct clades of *Photobacterium leiognathi*. *Arch Microbiol* 181:352–361
- Ast JC, Urbanczyk H, Dunlap PV (2007) Natural merodiploidy of the lux-rib operon of *Photobacterium leiognathi* from coastal waters of Honshu Japan. *J Bacteriol* 189:6148–6158
- Bassler BL (1999) How bacteria talk to each other: regulation of gene expression by quorum sensing. *Curr Opin Microbiol* 2:582–587
- Bassler BL, Wright M, Showalter RE, Silverman, MR (1993) Intercellular signalling in *Vibrio harveyi*, sequence and function of genes regulating expression of luminescence. *Mol Microbiol* 9:773–786
- Bassler BL, Wright M, Silverman MR (1994a) Sequence and function of LuxO, a negative regulator of luminescence in *Vibrio harveyi*. *Mol Microbiol* 12:403–412
- Bassler BL, Wright M, Silverman MR (1994b) Multiple signalling systems controlling expression of luminescence in *Vibrio harveyi*, sequence and function of genes encoding a second sensory pathway. *Mol Microbiol* 13:273–286
- Baumann P, Baumann L (1981) The marine Gram-negative eubacteria genera *Photobacterium*, *Beneckea*, *Alteromonas*, *Pseudomonas*, and *Alcaligenes*. In: Starr MP, Stolp H, Truper HG, Balows A, Schlegel HG (eds) *The prokaryotes*. Springer, Berlin, pp 1302–1331
- Blair JM, Webber MA, Baylay AJ, Ogbolu DO, Piddock LJ (2015) Molecular mechanisms of antibiotic resistance. *Nature Reviews Microbiology*, 13(1), 42-51
- Boto L (2010) Horizontal gene transfer in evolution: facts and challenges. *Proceedings of the Royal Society of London B: Biological Sciences*, 277(1683), 819-827
- Boucher Y, Douady CJ, Papke RT, Walsh DA, Boudreau MER, Nesbø CL, Doolittle, WF (2003) Lateral gene transfer and the origins of prokaryotic groups. *Annual review of genetics*, 37(1), 283-328
- Cao JG, Meighen EA (1989) Purification and structural identification of an autoinducer for the luminescence system of *Vibrio harveyi*. *J Biol Chem* 264:21670–21676
- Dodd IB, Perkins AJ, Tsemitsidis D, & Egan JB (2001). Octamerization of λ CI repressor is needed for effective repression of P_{RM} and efficient switching from lysogeny. *Genes & Development*, 15(22), 3013–3022

- Dunlap PV (2009) Bioluminescence, microbial. In: Schaechter M (ed) *Encyclopedia of microbiology*, 3rd edn. Elsevier, Oxford, pp 45–61
- Dunlap PV, Ast JC (2005) Genomic and phylogenetic characterization of the luminous bacteria symbiotic with the deep-sea fish *Chlorophthalmus albatrossis* (Aulopiformes Chlorophthalmidae). *Appl Environ Microbiol* 71:930–939
- Dunlap PV, Urbanczyk H (2013) Luminous Bacteria. In: Rosenberg E, DeLong EF, Thompson F, Lory S, Stackebrandt E (eds) *The prokaryotes* (4th ed) – Prokaryotic physiology and biochemistry. Springer, Berlin, pp 495–528
- Dunlap PV, Kojima Y, Nakamura S, Nakamura M (2009) Inception of formation and early morphogenesis of the bacterial light organ of the sea urchin cardinalfish, *Siphamia versicolor* (Perciformes Apogonidae). *Mar Biol* 156:2011–2020
- Engbrecht J, Nealson K, Silverman M (1983) Bacterial bioluminescence, isolation and genetic analysis of functions from *Vibrio fischeri*. *Cell* 32:773–781
- Feder ME (2007) Evolvability of physiological and biochemical traits: evolutionary mechanisms including and beyond single-nucleotide mutation. *Journal of Experimental Biology*, 210(9), 1653–1660
- Figge MJ, Robertson LA, Ast JC, Dunlap PV (2011) Historical microbiology: revival and phylogenetic characterization of luminous bacterial cultures of M. W. Beijerinck. *FEMS Microbiol Ecol* 78:463–472
- Fischer Le Saux M, Viillard V, Brunel B, Normand P, Boemare EN (1999) Polyphasic classification of the genus *Photobacterium* and proposal of new taxa *P. luminescens* subsp. *luminescens* subsp. nov., *P. luminescens* subsp. *Akhurstii* subsp. nov., *P. luminescens* subsp. *laumondii* subsp. nov., *P. temperata* sp. nov., *P. temperata* subsp. *temperata* subsp. nov., and *P. asymbiotica* sp. nov. *Int J Syst Bacteriol* 49:1645–1656
- Forst S, Dowds B, Boemare N, Stackebrandt E (1997) *Xenorhabdus* and *Photobacterium* spp. bugs that kill bugs. *Ann Rev Microbiol* 51:47–72
- Haddock SHD, Case JF (1994) A bioluminescent chaetognath. *Nature* 367:225–26
- Haddock SHD, Rivers TJ, Robison BH (2001) Can coelenterates make coelenterazine? Dietary requirement for luciferin in cnidarian bioluminescence. *Proc. Natl. Acad. Sci. USA* 98:11148–51
- Harper RD, Case JF (1999) Disruptive counterillumination and its anti-predatory value in the plainfish midshipman *Porichthys notatus*. *Mar. Biol.* 134:529–40
- Harvey EN (1922) *The production of light by the fishes photoblepharon and anomalops*. Carnegie Institute of Washington, Washington DC
- Harvey EN (1952) *Bioluminescence*. Academic, New York NY
- Hastings JW (1995) Bioluminescence. In: Sperelakis N (ed) *Cell physiology*. Academic, New York, NY, pp 665–681

- Hastings JW, Nealson KH (1981) The symbiotic luminous bacteria. In: Starr MP, Stolp H, Truper HG, Balows A, Schlegel HG (eds) *The prokaryotes*. Springer, Berlin, pp 1332–1345
- Haygood MG (1993) Light organ symbioses in fish. *Crit Rev Microbiol* 19:191–216
- Hendry TA, Dunlap PV (2011) The uncultured luminous symbiont of *Anomalops katoptron* (*Beryciformes Anomalopidae*) represents a new bacterial genus. *Mol Phylogenet Evol* 61:834–843
- Henke JM, Bassler BL (2004) Three parallel quorum-sensing systems regulate gene expression in *Vibrio harveyi*. *J Bacteriol* 186:6902–6904
- Herring PJ, Widder EA, Haddock SHD (1992) Correlation of bioluminescence emissions with ventral photophores in the mesopelagic squid *Abralia veranyi* (Cephalopoda: Enoploteuthidae). *Mar. Biol.* 112:293–98
- Ikejima K, Ishiguro N, Wada M, Kita-Tsukamoto K, Nishida M (2004) Molecular phylogeny and possible scenario of ponyfish (Perciformes: Leiognathidae) evolution. *Mol. Phylogenet. Evol.* 31:904–909
- Johnsen S, Widder EA, Mobley C (2004) Propagation and perception of bioluminescence: factors affecting counterillumination as a cryptic strategy. *Biol. Bull.* 207:1–16
- Jones DT, Taylor WR, and Thornton JM (1992) The rapid generation of mutation data matrices from protein sequences. *Computer Applications in the Biosciences* 8: 275-282
- Kaeding AJ, Ast JC, Pearce MM, Urbanczyk H, Kimura S, Endo H, Nakamura M, Dunlap PV (2007) Phylogenetic diversity and co-symbiosis in the bioluminescent symbioses of *Photobacterium mandapamensis*. *Appl Environ Microbiol* 73:3173–3182
- Kasai S, Okada K, Hoshino A, Iida T, Honda T (2007) Lateral transfer of the lux gene cluster. *J Biochem* 141:231–237
- Kelly RC, Bolitho ME, Higgins DA, Lu W, Ng WL, Jeffrey PD, Rabinowitz JD, Semmelhack MF, Hughson FM, Bassler BL (2009) The *Vibrio cholerae* quorum-sensing autoinducer CAI-1: analysis of the biosynthetic enzyme CqsA. *Nat Chem Biol* 5:891–895
- Kimura M (1980) A simple method for estimating evolutionary rate of base substitutions through comparative studies of nucleotide sequences. *Journal of Molecular Evolution* 16:111-120
- Kubodera T, Koyama Y, Mori K (2007) Observations of wild hunting behaviour and bioluminescence of a large deep-sea, eight-armed squid, *Taningia danae*. *Proc. Biol. Sci.* 274:1029–34
- Kumar S, Stecher G, and Tamura K. (2015) MEGA7: Molecular Evolutionary Genetics Analysis version 7.0 for bigger datasets. *Molecular Biology and Evolution* (submitted)
- Kurland CG, Canback B, Berg OG (2003) Horizontal gene transfer: a critical view. *Proceedings of the National Academy of Sciences*, 100(17), 9658-9662

- Le SQ and Gascuel O (2008) An Improved General Amino Acid Replacement Matrix. *Mol Biol Evol* 25(7):1307-1320
- Lee J, Matheson IBC, Muller F, O’Kane D, Veroort J, Visser AJWG (1990) The mechanism of bacterial bioluminescence. In: Muller F (ed) *Chemistry and biochemistry of flavoenzyme*, vol 2. CRC Press, Boca Raton, FL, pp 109–151
- Lee CY, O’Kane DJ, Meighen EA (1994) Riboflavin synthesis genes are linked with the lux operon of *Photobacterium phosphoreum*. *J Bacteriol* 176:2100–2104
- Lenz DH, Mok KC, Lilley BN, Kulkarni RV, Wingreen NS, Bassler BL (2004) The small RNA chaperone Hfq and multiple small RNAs control quorum sensing in *Vibrio harveyi*. *Cell* 118:69–82
- Lercher MJ, and Pál C (2008) Integration of horizontally transferred genes into regulatory interaction networks takes many million years. *Molecular biology and evolution*, 25(3), 559-567
- Lewis D, Le P, Zurla C, Finzi L, & Adhya S (2011). Multilevel autoregulation of λ repressor protein CI by DNA looping in vitro. *Proceedings of the National Academy of Sciences of the United States of America*, 108(36), 14807–14812
- Lilley BN, Bassler BL (2000) Regulation of quorum sensing in *Vibrio harveyi* by LuxO and sigma-54. *Mol Microbiol* 36:940–954
- Lin JW, Chao YF, Weng SF (1998) Characteristic analysis of the *luxG* gene encoding the probable flavin reductase that resides in the lux operon of *Photobacterium leiognathi*. *Biochem Biophys Res Commun* 246:446–452
- Lin JW, Chao YF, Weng SF (2001) Riboflavin synthesis genes *ribE*, *ribB*, *ribH*, *ribA* reside in the lux operon of *Photobacterium leiognathi*. *Biochem Biophys Res Commun* 284:587–595
- Makemson JC, Fulayfil N, Basson P (1992) Association of luminous bacteria with artificial and natural surfaces in Arabian Gulf seawater. *Appl Environ Microbiol* 58:2341–2343
- McElroy WD, Seliger HH (1962) Origin and evolution of bioluminescence. In: Kasha M, Pullman B (eds) *Horizons in biochemistry*. Academic, New York, NY, pp 91–101
- Meighen EA (1999) Autoinduction of light emission in different species of bioluminescent bacteria. *Luminescence* 14:3–9
- Meighen EA, Dunlap PV (1993) Physiological, biochemical and genetic control of bacterial bioluminescence. *Adv Microb Physiol* 34:1–67
- Mensingher AF, Case JF (1992) Dinoflagellate luminescence increases susceptibility of zooplankton to teleost predation. *Mar. Biol.* 112:207–10
- Moore SA, James MN (1995) Structural refinement of the non-fluorescent flavoprotein from *Photobacterium leiognathi* at 160 Å resolution. *J Mol Biol* 249:195–214
- Nealson KH, Hastings JW (1979) Bacterial bioluminescence its control and ecological significance. *Microbiol Rev* 43:496–518

- Nealson KH, Hastings JW (1992) The luminous bacteria. In: Balows A, Truper HG, Dworkin M, Harder W, Schleifer KH (eds) *The prokaryotes*, 2nd edn. Springer, Berlin, pp 625–639
- Nei M and Kumar S (2000) *Molecular Evolution and Phylogenetics*. Oxford University Press, New York, NY
- Nijvipakul S, Wongratana J, Suadee C, Entsch B, Ballou DP, Chaiyen P (2008) LuxG is a functioning flavin reductase for bacterial luminescence. *J Bacteriol* 190:1531–1538
- O’Grady EA. 2008. Ph.D. dissertation, University of Wisconsin-Milwaukee.
- Oliver JD, Roberts DM, White VK, Dry MA, Simpson LM (1986) Bioluminescence in a strain of the human pathogenic bacterium *Vibrio vulnificus*. *Appl Environ Microbiol* 52:1209–1211
- Palmer LM, Colwell RR (1991) Detection of luciferase gene sequence in nonluminescent *Vibrio cholerae* by colony hybridization and polymerase chain reaction. *Appl Environ Microbiol* 57:1286–1293
- Pietsch TW (2009) *Oceanic Anglerfishes: Extraordinary Diversity in the Deep Sea*. Berkeley: Univ. of Calif. Press. 576
- Preheim SP, Boucher Y, Wildschutte H, David LA, Veneziano D, Alm EJ, Polz MF (2011) Metapopulation structure of Vibrionaceae among coastal marine invertebrates. *Environ Microbiol* 13:265–275
- Price MN, Dehal PS, Arkin AP (2008) Horizontal gene transfer and the evolution of transcriptional regulation in *Escherichia coli*. *Genome biology*, 9(1), 1-20
- Rivers TJ, Morin JG (2008) Complex sexual courtship displays by luminescent male marine ostracods. *J. Exp. Biol.* 211:2252–62
- Robison BH, Reisenbichler KR, Hunt JC, Haddock SHD (2003) Light production by the arm tips of the deep-sea cephalopod *Vampyroteuthis infernalis*. *Biol. Bull.* 205:102–109
- Schaefer AL, Val DL, Hanzelka BL, Cronan JE Jr, Greenberg EP (1996) Generation of cell-to-cell signals in quorum sensing: acyl homoserine lactone synthase activity of a purified *Vibrio fischeri* LuxI protein. *Proc Natl Acad Sci USA* 93:9505–9509
- Schauder S, Shokat K, Surette MG, Bassler BL (2001) The LuxS family of bacterial autoinducers biosynthesis of a novel quorum-sensing signal molecule. *Mol Microbiol* 41:463–476
- Schikorski D, Renault T, Paillard C, Bidault-Toffin A, Tourbiez D, Saulnier D (2013) Development of TaqMan real-time PCR assays for monitoring *Vibrio harveyi* infection and a plasmid harbored by virulent strains in European abalone *Haliotis tuberculata* aquaculture. *Aquaculture* 392:106-112
- Schultz LW, Liu L, Cegielski M, Hastings JW (2005) Crystal structure of a pH-regulated luciferase catalyzing the bioluminescent oxidation of an open tetrapyrrole. *Proc. Natl. Acad. Sci. USA* 102:1378–83

Seliger, HH (1975). The origin of bioluminescence. *Photochemistry and photobiology*, 21(5), 355-361.

Seliger HH (1987) The evolution of bioluminescence in bacteria. *Photochem Photobiol* 45:291-297

Seliger, HH (1993). Bioluminescence: excited states under cover of darkness. *Naval Research Reviews*. 45, 5-5.

Shimomura O (2006) *Bioluminescence: Chemical Principles and Methods*. World Scientific, Toh Tuck Link, Singapore.

Showalter RE, Martin MO, Silverman MR (1990) Cloning and nucleotide sequence of *luxR*, a regulatory gene controlling bioluminescence in *Vibrio harveyi*. *J Bacteriol* 172:2946-2954

Silverman M, Martin M, Engebrecht J (1989) Regulation of luminescence in marine bacteria. In: Hopwood DA, Chater KF (eds) *Genetics of bacterial diversity*. Academic, London, pp 71-86

Sugiyama N, Shimomura O, Saiga Y, Haneda Y (1961) Crystalline luciferin from a luminescent fish, *Parapriacanthus beryciformes*. *Proc. Natl. Acad. Sci. USA* 47:486-89

Swartzman E, Miyamoto C, Graham A, Meighen E (1990) Delineation of the transcriptional boundaries of the *lux* operon of *Vibrio harveyi* demonstrates the presence of two new *lux* genes. *J Biol Chem* 265:3513-3517

Swartzman E, Silverman M, Meighen EA (1992) The *luxR* gene product of *Vibrio harveyi* is a transcriptional activator of the *lux* promoter. *J Bacteriol* 174:7490-7493

Tamura K and Nei M (1993) Estimation of the number of nucleotide substitutions in the control region of mitochondrial DNA in humans and chimpanzees. *Molecular Biology and Evolution* 10:512-526

Travers MA, Bidault-Toffin A, Barbou A, Schikorski D, Huchette S, Paillard C, Koken M (2012) pVCR1, a *Vibrio harveyi* plasmid specifically found in strains pathogenic for the European abalone, *Haliotis tuberculata* Linnaeus, 1758. *EMBL/GenBank/DDBJ databases*.

Tu KC, Bassler BL (2007) Multiple small RNAs act additively to integrate sensory information and control quorum sensing in *Vibrio harveyi*. *Genes Dev* 21:221-233

Tu KC, Long T, Svenningsen SL, Wingreen NS, Bassler BL (2010) Negative feedback loops involving small regulatory RNAs precisely control the *Vibrio harveyi* quorum-sensing response. *Mol Cell* 37:567-579

Urbanczyk H, Ast JC, Higgins MJ, Carson J, Dunlap PV (2007) Reclassification of *Vibrio fischeri*, *Vibrio logei*, *Vibrio salmonicida* and *Vibrio wodanis* as *Aliivibrio fischeri* gen. nov., comb. nov., *Aliivibrio logei* comb. nov., *Aliivibrio salmonicida* comb. nov. and *Aliivibrio wodanis* comb. nov. *Int J Syst Evol Microbiol* 57:2823-2829

- Urbanczyk H, Ast JC, Kaeding AJ, Oliver JD, Dunlap PV (2008) Phylogenetic analysis of the incidence of lux gene horizontal transfer in Vibrionaceae. *J Bacteriol* 190:3494–3504
- Urbanczyk H, Furukawa T, Yamamoto Y, Dunlap PV (2012) Natural replacement of vertically inherited lux-rib genes of *Photobacterium aquimaris* by horizontally acquired homologues. *Environ Microbiol Reports*. 4(4), 412–416
- Vallin A, Jakobsson S, Lind J, Wiklund C (2006) Crypsis versus intimidation—anti-predation defence in three closely related butterflies. *Behav. Ecol. Sociobiol.* 59:455–59
- Wannamaker, AM (2013) Master's thesis. University of Wisconsin-Milwaukee.
- Ward WW, Davis DF, Cutler MW (1994) The origin of chromophores in coelenterate bioluminescence. In *Bioluminescence and Chemiluminescence: Fundamentals and Applied Aspects*, ed. AK Campbell, LJ Kricka, PE Stanley, pp. 131–34. New York:Wiley
- Warner JA, Case JF (1980) The zoogeography and dietary induction of bioluminescence in the midshipman fish, *Porichthys notatus*. *Biol. Bull.* 159:231–46
- Waters CM, Bassler BL (2005) Quorum sensing cell-to-cell communication in bacteria. *Annu Rev Cell Dev Biol* 21:319–346
- Whyte M and Wimpee CW (2016) A highly divergent isolate suggests a previously undiscovered Aliivibrio species. *American Society for Microbiology*. Abstract
- Widder EA (2010) Bioluminescence in the ocean origins of biological, chemical, and ecological diversity. *Science* 328:704–708
- Wilson T, Hastings JW (1998) Bioluminescence. *Annu Rev Cell Dev Biol* 14:197–230
- Wollenberg MS, Preheim SP, Polz MF, Ruby EG (2011) Polyphyly of non-bioluminescent *Vibrio fischeri* sharing a lux-locus deletion. *Environ Microbiol*.
- Woodland DJ, Cabanban AS, Taylor VM, Taylor RJ (2002) A synchronized rhythmic flashing light display by schooling *Leiognathus splendens* (Leiognathidae: Perciformes). *Mar. Freshwater Res.* 53:159–62
- Woods W Jr, Hendrickson H, Mason J, Lewis S (2007) Energy and predation costs of firefly courtship signals. *Am. Nat.* 170:702–708
- Yoshizawa S, Wada M, Kita Tsukamoto K, Ikemoto E, Yokota A, Kogure K (2009a) *Vibrio azureus* sp. nov., a luminous marine bacterium isolated from seawater. *Int J Syst Evol Microbiol* 59:1645–1649
- Yoshizawa S, Wada M, Kita Tsukamoto K, Yokota A, Kogure K (2009b) *Photobacterium aquimaris* sp. nov., a luminous marine bacterium isolated from seawater. *Int J Syst Evol Microbiol* 59:1438–1442
- Yoshizawa S, Karatani H, Wada M, Yokota A, Kogure K (2010a) *Aliivibrio sifiae* sp. nov., luminous marine bacteria isolated from seawater. *J Gen Appl Microbiol* 56:508–518

Yoshizawa S, Wada M, Yokota A, Kogure K (2010b) *Vibrio sagamiensis* sp. nov., luminous marine bacteria isolated from seawater. *J Gen Appl Microbiol* 56:499–507

Zarubin M, Belkin S, Ionescu M, Genin A (2012) Bacterial bioluminescence as a lure for marine zooplankton and fish. *PNAS* 109:853–857

Appendix: Phylogenetic analysis of various conserved genes in bioluminescent bacteria

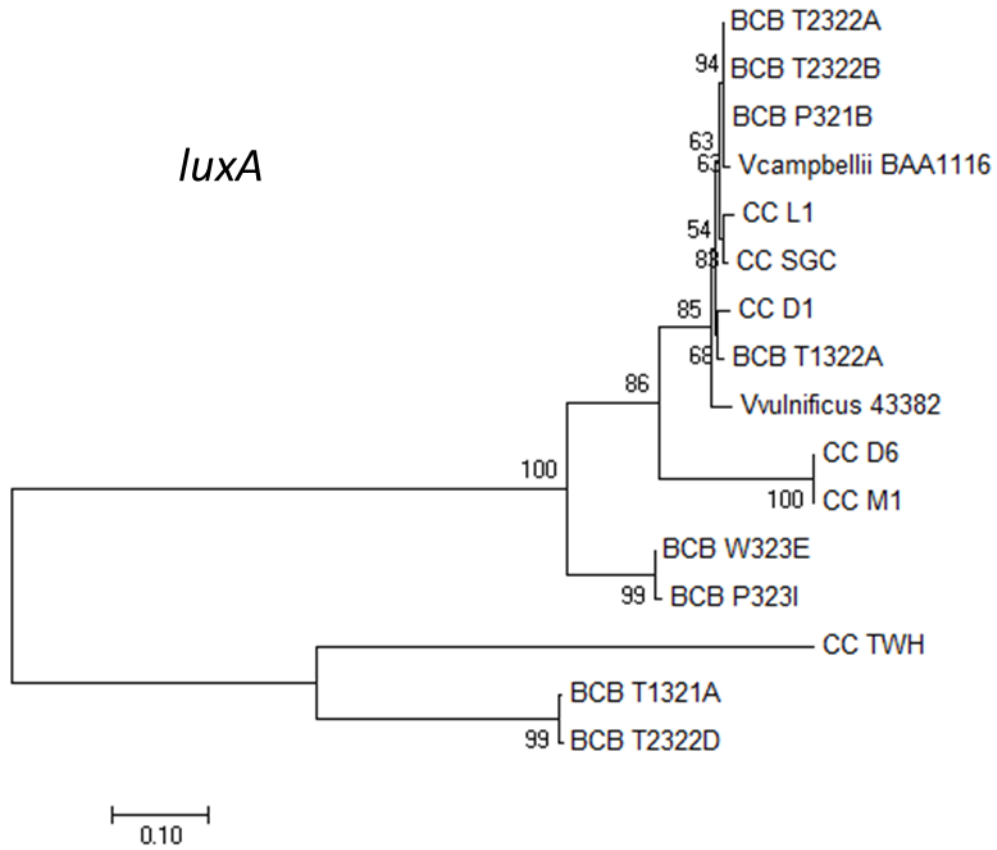

Phylogenetic analysis of bioluminescent bacterial species using the nucleotide sequence of *luxA*.

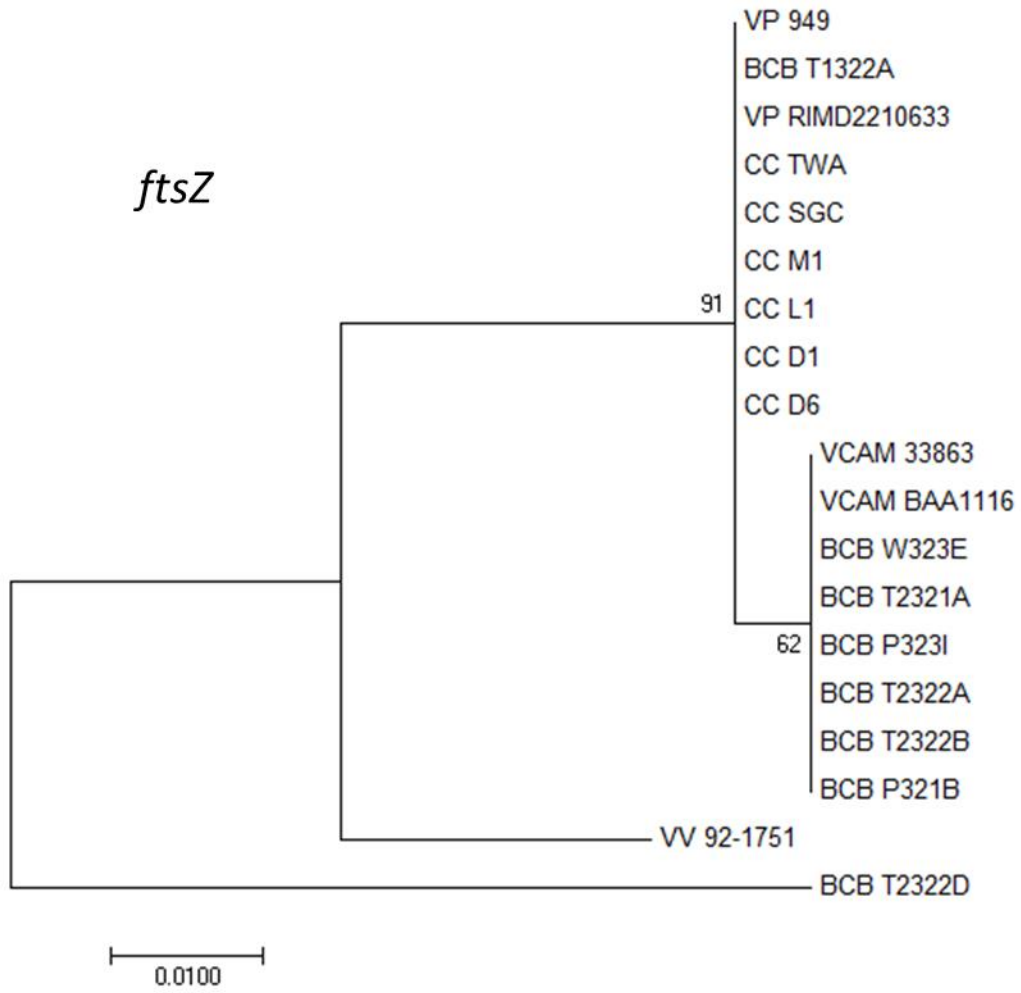

Phylogenetic analysis of species from the genus *Vibrio* using the amino acid sequence of *ftsZ*.

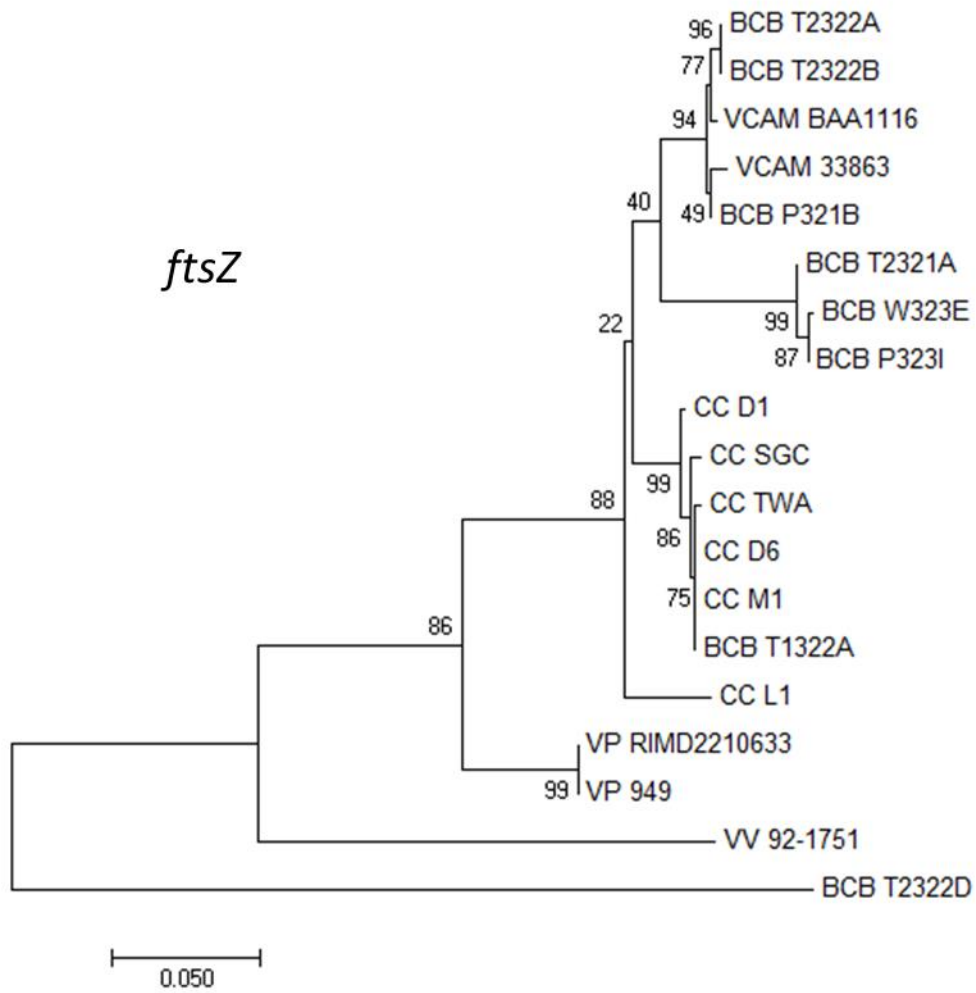

Phylogenetic analysis of species from the genus *Vibrio* using the nucleotide sequence of *ftsZ*.

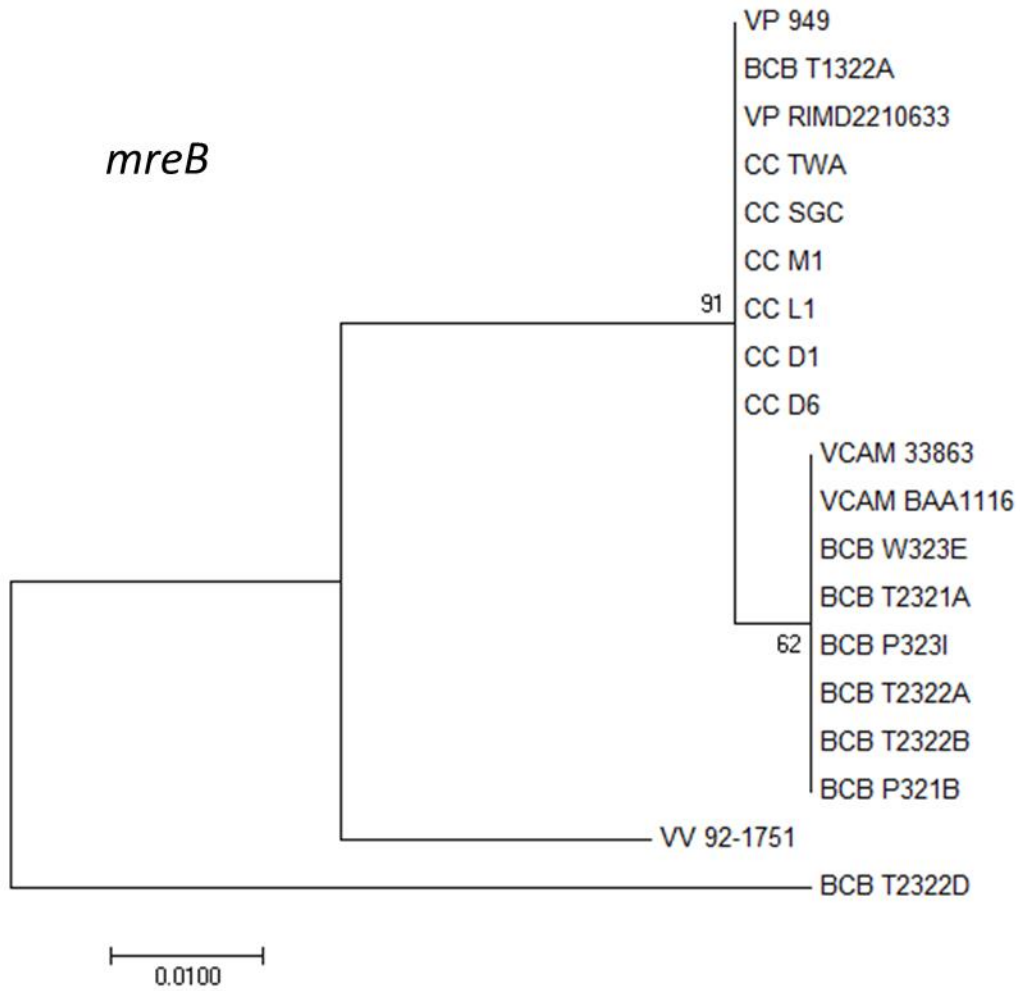

Phylogenetic analysis of species from the genus *Vibrio* using the amino acid sequence of *mreB*.

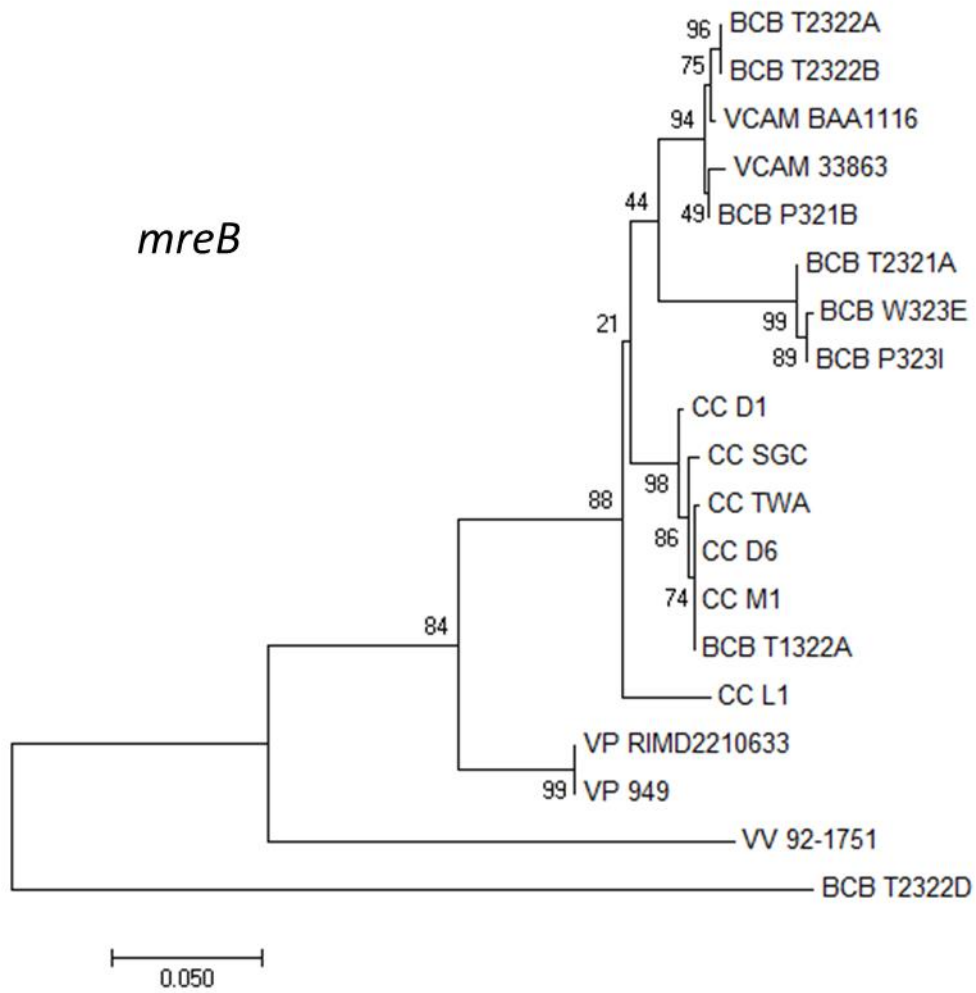

Phylogenetic analysis of species from the genus *Vibrio* using the nucleotide sequence of *mreB*.

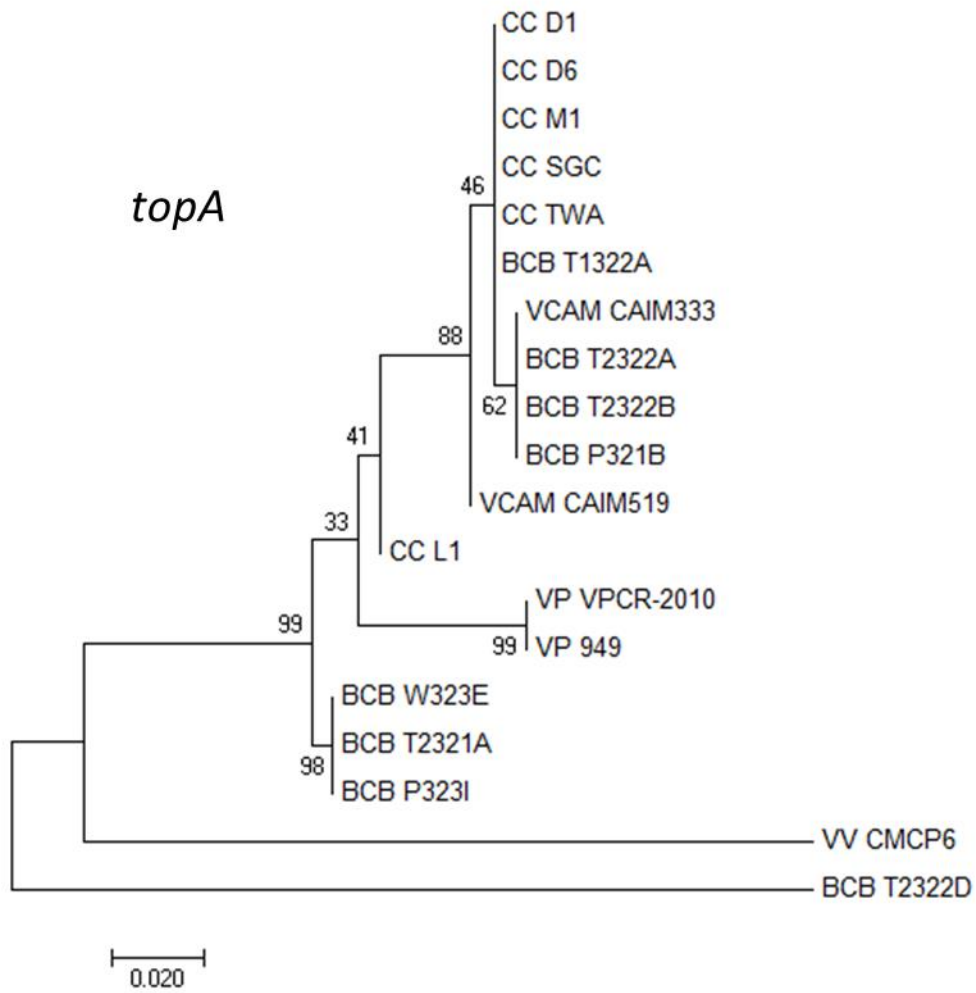

Phylogenetic analysis of species from the genus *Vibrio* using the amino acid sequence of *topA*.

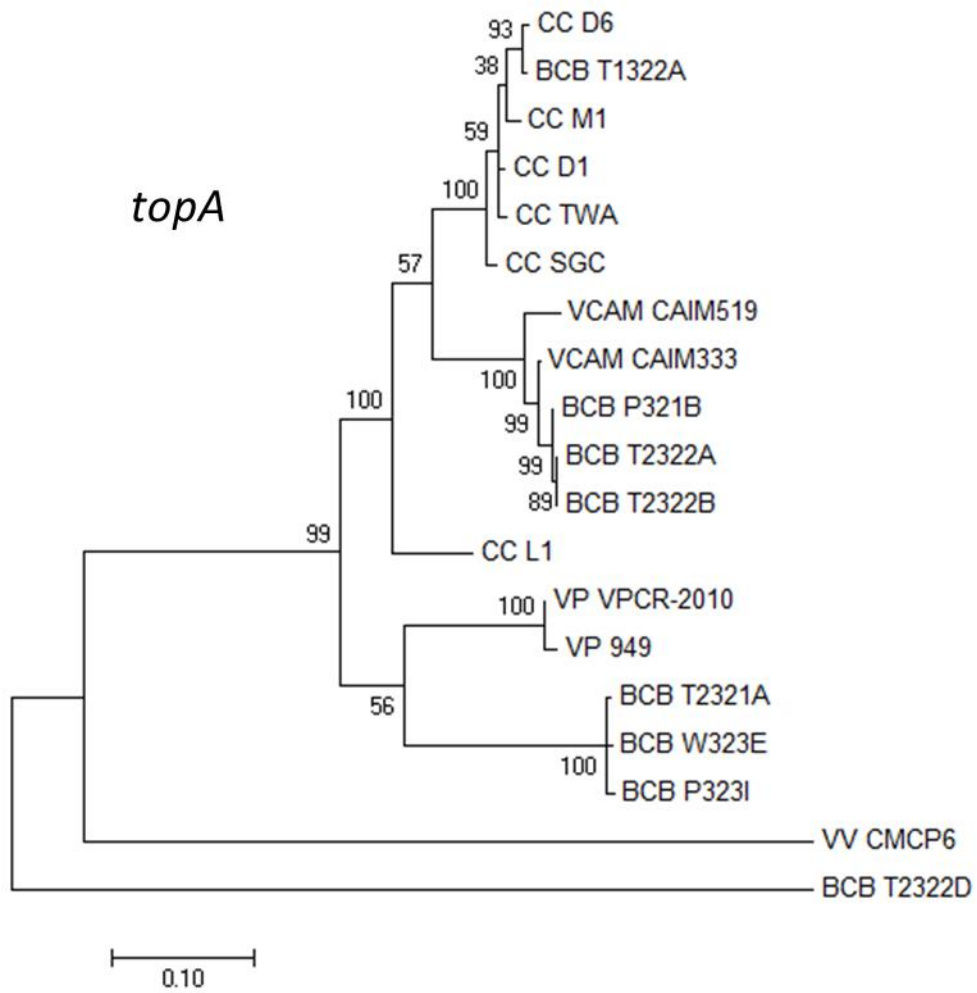

Phylogenetic analysis of species from the genus *Vibrio* using the nucleotide sequence of *topA*.