

Fractions

For

Welders

Grettel Hecht

A Master's Paper

*Submitted in Partial Fulfillment of
the Requirements for the Degree of
Master of Science in Education – Mathematics*

Advisor's Signature

Advisor's Signature

Date

University of Wisconsin-River Falls

2012

Table of Contents

Abstract.....	ii
Chapter 1 – Introduction.....	1
Chapter 2 – Review of Literature.....	17
Chapter 3 – Methods.....	42
Chapter 4 – Results.....	67
Chapter 5 – Reflection.....	80
Chapter 6 – References.....	87
Appendix A – Holiday Bows.....	89
Appendix B – Tuna Sandwiches.....	90
Appendix C – Fractions for Welders Pre-Test.....	91
Appendix D – Town Map.....	104
Appendix E – Learning Targets.....	107
Appendix F – BrainPOP Quiz 1.....	108
Appendix G – BrainPOP Quiz 2.....	113
Appendix H – Lesson Two Exit Slip.....	118
Appendix I – Lesson Three Team Challenge.....	119
Appendix J – Lesson Three Exit Slip.....	120
Appendix K – Lesson Three Independent Practice.....	123
Appendix L – Presentation Problems.....	127
Appendix M – Bomb Game Questions.....	129
Appendix N – Unit Exam.....	131

Abstract

Successfully teaching elementary school and middle level students how to understand and deal with rational numbers has been a source of exploration for many years. Specifically, many researchers have examined best practices for helping students grasp a conceptual understanding of fractions, including how to add, subtract, multiply, and divide with fractions. Additionally, many scholars have turned their attention to the comfort level prospective teachers have with regard to fractions; often veteran educators are included in these studies as well. The Fractions for Welders curriculum project involves alternative methods for teaching and learning how to perform basic operations with fractions. Fraction division is an area of focus but the scope of the project extends beyond one operation. Fundamental skills such as creating equivalent fractions (including those expressed in lowest terms) are also handled in a slightly nonstandard way. The phrase “version of one” is introduced and becomes a key component of the entire curriculum. The goal of the Fractions for Welders project is to analyze the effectiveness of a unique curriculum, originally developed for seventh graders, when it has been modified and then implemented in a technical college classroom containing second-semester welding students. This has been accomplished through careful examination of two pre-tests and two post-tests. Based on the outcomes of the pre- and post-tests there is evidence to verify the curriculum had an encouraging impact on the learners involved. Student growth and understanding was detected; yet, further modifications could still be made to produce a more effective unit on rational numbers.

Chapter 1

Introduction

The origins of this project date back to my first few years of teaching. My seventh graders would consistently struggle, year after year, to perform basic operations with fractions. One specific problem was division. Most of my students had already been taught to invert and multiply when attempting to divide with fractions. They seemed to enter seventh grade with a vague memory of this algorithm. Unfortunately, they also collectively entered my classroom with a tendency to consistently make the following three errors:

1. Before multiplying, students would invert the first fraction in the division problem. Using math terms, students would replace the dividend with its reciprocal instead of replacing the divisor with its reciprocal.
2. Before multiplying, students would replace both the dividend and the divisor with their reciprocals.
3. In division problems where the divisor was a mixed number, students would correctly rewrite the divisor as an improper fraction and then proceed to multiply (forgetting to replace the improper fraction with its reciprocal).

These errors, and others like them, appeared to be some of the negative effects of students being taught a procedure instead of being taught to understand a concept. The conflict between procedural and conceptual understanding is not new. Teachers often feel they lack the time it takes to fully develop a basic, much less a complex, mathematical concept with their students. Some teachers simply do not possess the background knowledge themselves to effectively teach for conceptual understanding. For these reasons, among others, teachers regularly demonstrate processes, steps, and algorithms without ever really explaining a given concept as a whole; we fall back on the “how” and ignore the “why”.

Despite making mistakes fairly often when utilizing the algorithm they had been taught, students were resistant when I would present another method such as dividing straight across. Dividing straight across was something they had been specifically taught never to do. I wanted to talk with the sixth grade math teachers to clarify their approach to dividing fractions; however, I did not want to offend any veteran educators. I decided to speak with an approachable eighth grade teacher instead. He looked at me like I was crazy when I told him I had been teaching students to divide straight across whenever possible and to invert and multiply (which I called “Plan B”) only as a last resort. I actually had to prove to him, on a napkin, that my “Plan A” method was mathematically accurate:

- PLAN A – “DIVIDE STRAIGHT ACROSS”

$$\frac{a}{b} \div \frac{c}{d} = \frac{\frac{a}{c}}{\frac{b}{d}} = \frac{a}{c} \div \frac{b}{d} = \frac{a}{c} \times \frac{d}{b} = \frac{ad}{cb}$$

- PLAN B – TRADITIONAL “INVERT AND MULTIPLY”

$$\frac{a}{b} \div \frac{c}{d} = \frac{a}{b} \times \frac{d}{c} = \frac{ad}{bc}$$

Soon after that conversation, I began to rethink how I had been teaching students to simplify fractions. I started to discuss fraction reduction in terms of dividing by a “version of one”. For example, $\frac{9}{21}$ can be reduced by dividing it by $\frac{3}{3}$ to get $\frac{3}{7}$. I started realizing that if I taught students how to simplify fractions using division, then division itself became more familiar and less scary for them. They were also less resistant to the dividing straight across approach. I was also pleased to reinforce the right-sided identity element of division, the concept that any real number a divided by 1 equals a . However, it is important to note that $1 \div a \neq a$ ($1 \div a = 1/a$, the reciprocal of a). Eventually, my fraction units started to follow this progression:

- FRACTION FUNDAMENTALS

- EQUIVALENT FRACTIONS – I reinforced the identity property of multiplication by teaching students to create equivalent fractions by multiplying given fractions by versions of one. For example,

$$\frac{5}{6} \times \frac{4}{4} = \frac{20}{24}.$$
- SIMPLIFYING FRACTIONS – Just as creating equivalent fractions was teaching students to multiply, simplifying fractions was teaching them to divide.
- MULTIPLYING AND DIVIDING FRACTIONS – It seemed natural to teach these operations first, especially since they had already been taught!
- ADDING AND SUBTRACTING FRACTIONS – Since creating equivalent fractions with specific denominators is key to these skills, it seemed appropriate to teach these only after students had mastered multiplication.

I started to see other benefits to this approach. Students were better prepared to perform unit conversions. Instead of versions of one like $\frac{2}{2}$ and $\frac{10}{10}$, they would soon be multiplying measurements and rates by fractions like $\frac{1 \text{ hr.}}{60 \text{ min.}}$ and $\frac{5280 \text{ ft.}}{1 \text{ mi.}}$ (also versions of one) in order to convert between units. Consider the following problem: A yardstick is 36 inches; what is this length in centimeters? Students in my classes are taught to solve problems like this by multiplying the given measurement by a carefully chosen version of one. Since the conversion in question involves inches and centimeters, their only options for finding a solution are either $\frac{36 \text{ in.}}{1} \times \frac{1 \text{ in.}}{2.54 \text{ cm.}}$ or $\frac{36 \text{ in.}}{1} \times \frac{2.54 \text{ cm.}}{1 \text{ in.}}$. Students should recognize that since the first possibility would create units of $\frac{\text{in.}^2}{\text{cm.}}$ and the second possibility would result in centimeters, the latter is the correct multiplication problem to use for this conversion. Another benefit to teaching multiplication and division first seemed to be that students stopped thinking they needed common denominators in order to multiply or divide fractions (a common mistake when lots of time is spent on addition and subtraction before multiplying and dividing).

When I was asked to teach Math 373 at Wisconsin Indianhead Technical College (WITC) in the spring of 2012, I immediately started preparing. I was still relatively new to teaching adult learners; the previous fall semester had been my first foray into the technical college world. Prior to the fall of 2011, my teaching career had consisted of eight years at the middle level followed by a short stint as a maternity substitute at the high school level. Nevertheless, I had thoroughly enjoyed my fall class and genuinely looked forward to a second semester of teaching adult students. All I knew, at first, was I would be teaching a math class for students in the welding program. I read through the official WITC Collegewide Outcomes (CWOs). There are six universal outcomes which apply to every student who has graduated from a WITC program (regardless of his/her area of study):

1. Communicate Effectively
2. Demonstrate Critical Thinking Skills
3. Apply Mathematics
4. Use Science/Technology
5. Practice Social Interaction
6. Enhance Local/Global Perspectives

Further preparation included borrowing a couple of welding textbooks and ordering Welding for Dummies (Farnsworth, 2010) online. I started brushing up on what I thought I would be teaching. I found formulas for finding the cross-sectional areas of groove welds and fillet welds, I learned about deposition efficiency, I studied tables of values related to deposition rates of different electrodes, and I talked to every welder I knew. I assumed (incorrectly, it turns out) that teaching adult learners in a welding program at a technical college would involve covering vastly different content than I had been teaching to pre-algebra students in middle school. WITC has Course Outcome Summaries for each of its courses; a Course Outcome Summary (COS) is a curriculum document that includes course development details, course description, number of credits, competencies, performance standards (conditions and

criteria), and learning objectives. The official course description for Math 373 states the “course covers practical applications of whole numbers, fractions, decimals, percent, proportion, and formula evaluation”. The course also includes measurement, U.S and metric systems of measurement, and basic geometry.” By the end of the course, according to the COS, students should be able to:

1. calculate arithmetic operations using whole numbers.
2. calculate arithmetic operations using fractions.
3. calculate arithmetic operations using decimals.
4. solve proportions.
5. solve commonly occurring percentage problems.
6. convert within and between the English and metric systems.
7. solve first-degree algebraic equations.
8. demonstrate the ability to use formulas.

When I received the COS for Math 373 and discovered the first three units of study required students to perform basic operations with whole numbers, fractions, and decimals, I was motivated. However, when I read the sixth competency and realized unit conversions would be an essential component of my students’ technical program, I recognized conditions were finally perfect for a curriculum project that I had slowly been working on for close to a decade.

Preparing to teach Math 373 (Math for Welders) at WITC caused me to think a great deal about how I would present fairly straightforward mathematical concepts (like operations with whole numbers and fractions) to a very specific group of adult learners. I decided to first examine the three specific technical math textbooks I had at hand: Practical Problems in Mathematics: For Welders (Chasan, 2009), Math For Welders (Marion, 2006), and Applied College Mathematics for Math 373 (Ewen & Nelson, 2011). The last text was the textbook my welding students would be required to purchase to accompany the class. All three texts followed the same general approach with regard to fractions. Each

author spent time introducing fractions, then discussed how to add and subtract using fractions, and then examined fraction multiplication and division. One of the textbooks (Practical Problems in Mathematics: For Welders) went a bit further and delved into some problems where multiple operations with fractions were needed to solve practical problems.

I looked closely at how each author chose to introduce the very idea of a fraction. I specifically wanted to see how the authors handled naming the components of a fraction, creating equivalent fractions, and simplifying fractions. Applied College Mathematics for Math 373 (2011) includes the most comprehensive discussion about the numerator and denominator of a fraction. While the other two texts use phrases like “top number” (Chasan, 2009, p. 15), “bottom number” (Chasan, 2009, p. 15), and “the denominator is down on the bottom” (Marion, 2006, p. 44), Ewen and Nelson opt for a more complete description:

The integer below the line is called the *denominator*. It gives the denomination (size) of equal parts into which the fraction unit is divided.

The integer above the line is called the *numerator*. It numerates (counts) the number of times the denominator is used (Ewen & Nelson, 2011, p. 28).

I was extremely appreciative of this description because it validated years of my own teaching practices. I have become quite accustomed to getting students to focus on size first when dealing with fractions. When I help frustrated students operate with fractions, my first question is often, “OK, the pieces we have in this problem...what size are they?” Basically, I want my students to come across a fraction like $\frac{3}{7}$ and think or say “sevenths” instead of just “seven”.

Two of the textbooks combined their explanations of simplifying fractions and creating equivalent fractions. I will expand on these approaches shortly. First, though, it is interesting to examine how Chasan deals with both concepts. His nonsensical opening sentence under the bold heading “**REDUCING FRACTIONS**” states “the final step to do to the answer is to reduce the fraction, if

possible, to its lowest terms” (Chasan, 2009, p. 18). This statement about the final step to an invisible problem is followed by three examples (one is shown below).

$$\frac{2}{4} \longrightarrow \frac{2 \div 2}{4 \div 2} = \frac{1}{2} \text{ (Chasan, 2009, p. 18).}$$

Chasan then shares a final summary about reducing fractions. “Both top and bottom number have to be divided by the same number. In examples 1 and 2, dividing by 2 worked. In example 3, dividing by 3 worked. Some fractions cannot be reduced” (Chasan, 2009, p. 19). It was disheartening to read this in a math textbook. Dividing a fraction by two, three, or any number other than one will never result in an equivalent fraction! This passage reinforced my belief in the importance of teaching students to divide by a carefully chosen version of one in order to reduce a fraction to its lowest terms. Practical Problems in Mathematics: For Welders (2009) was also a bit of a disappointment in terms of its discussion of equivalent fractions; it was virtually nonexistent. No mention was made of creating equivalent fractions in the introductory pages of the fraction unit. Chasan chooses to wait, I assume, until he feels this skill is urgently needed to introduce the concept. He brings it up when examining how to add fractions with unlike denominators:

Fractions cannot be added if their denominators are unlike $(\frac{1}{8} + \frac{3}{4})$.

Therefore, it is necessary to change all the denominators to the same quantity. This change to the bottom number can only be done with multiplication. At times, only 1 fraction needs to be changed (made larger), and at other times all need to be changed... If the bottom number of a fraction is multiplied by a number, you must also multiply the top of that fraction by the same number (Chasan, 2009, p. 28).

Chasan works through the sample problem mentioned in the passage above, stating “since the bottom is multiplied by 2, we must multiply the top by 2 also” (Chasan, 2009, p. 28). He teaches students to show their work in this way: $\frac{3 \times 2=6}{4 \times 2=8}$ (Chasan, 2009, p. 28). I struggle to accept this way of teaching the

creation of equivalent fractions for four reasons. One, I would like to see Chasan use the standard terminology when describing the components of a fraction (especially this far into the fraction unit). Two, I am still shocked at his parenthetical implication that changing a fraction means making it larger. I tend to think students of all ages need to be taught to avoid that exact same train of erroneous thought. Fundamentally, a distinction needs to be made between changing the value of a fraction and simply changing its appearance. Three, I am uncomfortable with how Chasan focuses on the *quantities* of eight and four instead of the *denominations* of eighths and fourths; and four, I do not like to see student work resembling his example $\left(\frac{3 \times 2=6}{4 \times 2=8}\right)$. I would always rather see this: $\frac{3}{4} \times \frac{2}{2} = \frac{6}{8}$. After reviewing Practical Problems in Mathematics: For Welders (2009), I found myself grateful that I could use the book purely as a supplement to the text purchased by my students. Chasan's text contains excellent practical problems and terrific illustrations, even if the lessons themselves are lacking accuracy and clarity.

Both Applied College Mathematics for Math 373 (2011) and Math for Welders (2006) present the concept of creating equivalent fractions as an action with two potential results: a fraction equal in value but in higher terms (a fraction with a larger numerator and denominator) or a fraction equal in value but in lower terms (a fraction with a smaller numerator and denominator). So, the process of simplifying a fraction or reducing a fraction to lowest terms is demystified a bit for students immediately. Instead of treating the process of simplifying as a disjoint and random task to be completed at the end of a problem, the authors of Applied College Mathematics for Math 373 (Ewen & Nelson, 2011) and Math for Welders (Marion, 2006) seem to be making an attempt to help students form connections and develop a deeper understanding of equivalent fractions in general. While I certainly appreciate the attempt and the joint presentation, I do not think Marion does a very good job of presenting *why* the resulting fractions are equal in value to the original fractions. If an author skips the *why*, then the focus becomes the *how*. Instead of conceptual understanding, students wind up with

memorized procedures. Marion's demonstration of how to create equivalent fractions in both higher and lower terms is shown below.

Multiply the numerator and denominator of a fraction by the same number and the fraction will then be expressed in higher terms. The value of the two fractions will be the same, as illustrated:

$$\begin{array}{l} \underline{3} \text{ multiplied by } 7 = \underline{21} \\ 4 \text{ multiplied by } 7 = 28 \quad \dots \end{array}$$

If you divide both the numerator and denominator of a fraction by the same number, the fraction will be reduced. The value of the fraction will not be changed. The numbers, of course, must divide evenly ... as illustrated:

$$\begin{array}{l} \underline{24} \text{ divided by } 6 = \underline{4} \\ 30 \text{ divided by } 6 = 5 \end{array} \quad (\text{Marion, 2006, p. 45}).$$

Again, the algorithm is clearly and simply explained. Unfortunately, students are never shown why multiplying or dividing the numerator and denominator of a given fraction by the same number results in a fraction of equal value. Ewen and Nelson in Applied College Mathematics for Math 373 (2011) present this concept similarly, with two notable differences. First, they utilize symbols instead of words throughout their examples. "For example, $\frac{4}{9} = \frac{4 \cdot 5}{9 \cdot 5} = \frac{20}{45}$ " (Ewen & Nelson, 2011, p. 29). Secondly, after presenting one example of simplifying using division ($\frac{6}{10} = \frac{6 \div 2}{10 \div 2} = \frac{3}{5}$) they introduce prime factorizations as the preferred method for reducing a fraction to lowest terms (Ewen & Nelson, 2011, p. 29). For example, they instruct students to simplify the fraction $\frac{84}{300}$ by finding the prime factorization of 84 ($2 \cdot 2 \cdot 3 \cdot 7$) and 300 ($2 \cdot 2 \cdot 3 \cdot 5 \cdot 5$) and then crossing out all the twos and threes, leaving $\frac{7}{5 \cdot 5} = \frac{7}{25}$. No mention is made of why any digits should be crossed out of the problem. Students are shown a set of steps to follow without a sense of why those steps produce the desired result. I would prefer the Ewen and Nelson method if they had stopped to explain that students are allowed to cross out numbers

because $\frac{2}{2}$ and $\frac{3}{3}$ equal one! Or, it would have been considerate to offer a few alternative ways to simplify the fraction such as $\frac{84}{300} \div \frac{12}{12} = \frac{7}{25}$ or even $\frac{84}{300} \div \frac{2}{2} = \frac{42}{150} \div \frac{2}{2} = \frac{21}{75} \div \frac{3}{3} = \frac{7}{25}$, which is how most of my seventh graders would have attacked the problem. I realize this approach may not be the most efficient way of arriving at a fraction in simplest form; however, I would argue it represents the best conceptual understanding of equivalent fractions.

In each textbook, lessons concerning basic operations (addition, subtraction, multiplication, division) with fractions follow the introductory lesson(s). Two of the books (Practical Problems in Mathematics: For Welders and Math for Welders) devote four individual lessons to the four basic operations while the third (Applied College Mathematics for Math 373) teaches addition and subtraction together in a single lesson followed by multiplication and division together in a second lesson. In my own teaching career, I have tackled operations with fractions both ways. When I taught remedial math to seventh graders, I tended to teach one operation at a time. When I taught pre-algebra and Algebra I, however, I dealt with addition and subtraction together; multiplication and division were also taken care of simultaneously.

It is interesting to note that only the authors of Applied College Mathematics for Math 373 (2011) chose to spend considerable time explaining how to add and subtract fractions with common denominators. One text (Practical Problems in Mathematics: For Welders) never addresses this type of problem. Math for Welders devotes three sentences to this kind of question. "Fractions can be added only if they have the same denominators. For example, $\frac{3}{11}$ and $\frac{4}{11}$ have a **common denominator**. To add them, just add the numerators ($3 + 4 = 7$) and place this answer over the common denominator ($\frac{7}{11}$)" (Marion, 2006, p. 49). It is unfortunate that Marion never explains *why* the answer is $\frac{7}{11}$. I think a visual representation or at least a more detailed discussion of parts of a whole would be helpful here. Ewen and Nelson give five examples demonstrating how to add and subtract fractions with common

denominators as well as two fairly straightforward algebraic examples: $\frac{a}{c} + \frac{b}{c} = \frac{a+b}{c}$ ($c \neq 0$) (Ewen & Nelson, 2011, p. 33) and $\frac{a}{c} - \frac{b}{c} = \frac{a-b}{c}$ ($c \neq 0$) (Ewen & Nelson, 2011, p. 36). Together with the examples, students are presented with a pretty clear-cut algorithm for handling problems of this nature; however, that is *all* they are given. Unfortunately, many students who appear to master this procedure without a conceptual understanding find that they actually have *not* mastered the procedure. This discrepancy, in my experience, comes to light once they also try to memorize the algorithms for multiplying and dividing fractions. Without a deeper understanding of why it is important to have common denominators in some problems (addition/subtraction) and not in others (multiplication/division), students tend to combine or completely mix-up all of the algorithms and procedures They have been taught.

All three textbooks address finding the least common denominator (LCD) when adding or subtracting fractions with unlike denominators. Again, all three focus on *how* to find the LCD in a given problem instead of explaining *why* a common denominator (and not necessarily the LCD) is important. There are not any visual aids in any of the texts to help with the discussion, either. I have already covered how Chasan quickly deals with changing “all the denominators to the same quantity” in Practical Problems in Mathematics: For Welders (Chasan, 2009, p. 28). In contrast, it takes Ewen and Nelson three pages to explain the prime factorization method for finding the LCD of two or more fractions in Applied College Mathematics for Math 373 (2011). They have got tables, examples, rules, and reminders.

To find the least common denominator (LCD) of a set of fractions:

1. Factor each denominator into its prime factors.
2. Write each prime factor the number of times it appears *most* in any *one* denominator in Step 1. The LCD is the product of these prime factors (Ewen & Nelson, 2011, p. 34).

Marion uses a different approach with regard to finding the LCD. He humorously calls it “efficient” (Marion, 2006, p. 49).

1. Add the following fractions:

$$\frac{5}{6} + \frac{3}{8} + \frac{2}{3}$$

2. Write all denominators in a row. It is a good idea to separate them by commas so they do not blend together.

6, 8, 3

3. Find a number which divides evenly into at least two of the numbers listed. In this example, 2 will work. Divide using the format illustrated.

$$\begin{array}{r} 2 \) \ \underline{6, 8, 3} \\ \quad 3, 4, 3 \end{array}$$

Here is what happened. Two divided evenly into 6 three times, so 3 was written down. Two divided evenly into 8 four times, so 4 was written down. Then, 2 did not divide evenly into 3, so the 3 was “brought down.”

4. The next step follows the pattern of the previous step. This time inspect the new line of 3, 4, 3 to find a number that divides evenly into at least two of the numbers. Obviously, the number is 3.

$$\begin{array}{r} 2 \) \ \underline{6, 8, 3} \\ 3 \) \ \underline{3, 4, 3} \\ \quad \quad 1, 4, 1 \end{array}$$

At this point, the line of digits cannot be reduced further.

5. Now multiply the numbers 2, 3, 1, 4, 1:

$$2 \times 3 \times 1 \times 4 \times 1 = 24$$

The LCD is 24 (Marion, 2006, p. 49-50).

I worry such an emphasis on finding the LCD for a given addition or subtraction problem would affect student understanding in two ways. First, I am concerned students would not realize they have options when it comes to choosing a denominator to work with in a given problem. If students think getting the right answer to a problem critically depends on finding the *correct* denominator, they may become discouraged and hung up on that step instead of focusing on understanding the problem as a whole. Another issue I have seen students struggle with is they start to automatically approach *every* problem involving fractions by first finding the LCD. They even do this with problems dealing with multiplication and division, leading to frustration when denominators get extremely large ($\frac{3}{14} \times \frac{5}{9} = \frac{27}{126} \times \frac{70}{126} = \frac{1,890}{15,876}$) and wrong answers when they forget to multiply the denominators ($\frac{3}{14} \times \frac{5}{9} = \frac{27}{126} \times \frac{70}{126} = \frac{1,890}{126}$).

Finally, I will turn my attention to how each of the three technical math textbooks handles division with fraction. As I have stated, Ewen and Nelson address division right along with fraction multiplication in Applied College Mathematics for Math 373 (2011). The other two textbooks focus on division in stand-alone lessons. The most interesting commonality between all of the authors is they all teach one method for dividing: invert and multiply. All three textbooks use virtually the same terminology and types of examples to present this concept.

The method presented within Applied College Mathematics for Math 373 (2011) is concise and to the point. “To divide a fraction by a fraction, invert the fraction (interchange the numerator and denominator) that follows the division sign (\div). Then multiply the resulting fractions” (Ewen & Nelson, 2011, p. 46).

Marion, in Math for Welders, offers an encouraging pep talk to students at the beginning of his lesson on division. “Learning to divide fractions is quite easy once you have learned to multiply

fractions” (Marion, 2006, p. 73). Again, I am bemused to find that simply because an algorithm is relatively easy, it is the only procedure presented. Marion continues:

To divide, **invert the divisor** (that is, turn the divisor upside down) and change the operation from a division to a multiplication. Remember, the divisor is the number doing the division. In the following example, $\frac{3}{5}$ is being divided by $\frac{5}{8}$, the divisor.

$$\frac{3}{5} \div \frac{5}{8} = \frac{3}{5} \times \frac{8}{5} = \frac{24}{25}$$

It may seem odd that a division problem can suddenly be switched to a multiplication problem. Although they are opposite operations, multiplication and division are closely related. Because of this close relationship it is possible to convert fractional division problems to multiplications as shown above (Marion, 2006, p. 73).

While I appreciate Marion’s half-hearted attempt to take up the issue of *why* we are allowed to switch a division problem to a multiplication problem, I do not think mentioning the fact the two operations are “closely related” accomplishes this goal.

Finally, the author of Practical Problems in Mathematics: For Welders (2009) offers the following instruction. “Change the division sign into multiplication (x), and invert (flip) the following fraction. Do not flip the fraction in front of the sign. You are now back into multiplication. Follow multiplication rules” (Chasan, 2009, p. 45). Again, Chasan offers a crude but simple explanation of one way to divide fractions; students who are able to memorize several algorithms and keep them all straight may learn easily from lessons like those in these textbooks. Many students, however, may simply become confused and frustrated with the lack of intuitive understanding offered by these authors.

After fully exploring the lessons offered in the three technical mathematics textbooks at my disposal, I pulled out the sixth grade curriculum, the Connected Mathematics Project. Specifically, I

considered Bits and Pieces II: Using Rational Numbers (2004) by Lappan, Fey, Fitzgerald, Friel, and Phillips. I have been using this particular book to supplement my fraction lessons since Hudson Middle School piloted (and decided against adopting) the Connected Mathematics curriculum back in 2003. In stark contrast to the procedures presented in the technical math texts discussed previously, the authors of the Connected Mathematics Project opt to “help students make sense of how and why addition and subtraction of fractions work. The student edition does not give algorithms for adding and subtracting fractions. Instead, strategies are developed during the class discussions after students have worked on the problems” (Lappan et al., 2004, p. 42d).

One of my favorite examples of this is the Tupelo township problem. In the first lesson, students are simply given a map of two sections of a fictional town. 12 residents live in these two sections. Students are asked to “determine what fraction of a section each person owns” (Lappan et al., 2004, p. 43). In the second lesson, some owners move away and sell their land to owners who stay put. Students are asked to redraw the map and are forced to add fractions in the process; I have actually seen groups of students correctly simplify the following expressions *without any instruction*:

- $\frac{1}{16} + \frac{5}{32} + \frac{5}{32} + \frac{1}{32}$
- $\frac{3}{16} + \frac{5}{16}$
- $\frac{1}{4} + \frac{3}{16} + \frac{1}{16}$
- $\frac{3}{32} + \frac{3}{16} + \frac{5}{16}$

In a further extension of this same problem, more buying and selling makes students solve subtraction problems such as:

- $\frac{1}{2} - \frac{1}{8}$
- $\frac{19}{32} - \frac{1}{16}$

Again, students are able to intuitively solve problems like this without first solving subtraction problems with common denominators and (more significantly) without first being taught how to find the LCD of the problem. Even if a traditional fraction lesson follows, I have to believe students who experience this type of lesson first will have a better conceptual understanding of the procedures they are learning.

After carefully studying and analyzing the fraction lessons within the textbooks I had to work with, it was clear to me I would need to develop an original unit of curriculum to meet the needs of my welding students. I hoped the ideas, activities, and lessons I had effectively used with seventh graders would transfer well to a group of adult learners at the college level. I decided to view the welding mathematics texts as helpful supplements instead of learning centerpieces. Each book truly did contain valuable welding-related problems which I could use to enhance in-class activities and create homework assignments. Armed with both years of professional experience related to teaching fractions at the middle level as well as helpful auxiliary resources, I felt I had an excellent chance to generate a quality unit of curriculum designed with the best interests of my students in mind.

Chapter 2

Review of Literature

Generally speaking, sound curriculum design does not happen in a vacuum. Activities and ideas need to be gathered and massaged, discarded and replaced, researched and tested. It is important to examine recent and relevant research before developing a unit; a rational numbers unit for a group of second-semester college students is no exception. Three key themes materialize throughout this review. First, fostering student conceptual understanding (also referred to as relational understanding or object-based thinking) over procedural understanding (also denoted as instrumental understanding or process-based thinking) continues to be an issue of great importance. Next, teacher understanding in the United States of division by fractions is frequently limited to a procedural understanding of the standard algorithm, invert and multiply. Finally, students (as well as teachers) who are able to utilize alternative methods of division by fractions ultimately have a deeper relational understanding of the concept.

According to Skemp (2006), there are two different meanings to the word ‘understanding’. Relational understanding is “knowing both what to do and why” (Skemp, 2006, p. 89). He admits he has not always thought of instrumental understanding as understanding at all, merely “rules without reasons” (Skemp, 2006, p. 89). At some point he realized “that for many pupils *and their teachers* the possession of such a rule and the ability to use it, was what they meant by ‘understanding’” (Skemp, 2006, p. 89). Skemp encourages his readers to find examples of instrumental explanations in textbooks available to them. He argues that most teachers will be stunned by how widespread this approach is to teaching and learning. A classic example of a rule without reason is ‘turn it upside down and multiply’ for division by a fraction. I will delve further into this specific example throughout this review. While Skemp is obviously biased toward relational understanding, I appreciate the fact that he admits the

superiority of relational understanding over instrumental understanding is not “a self-evident truth which requires no justification” (Skemp, 2006, p. 91). He readily acknowledges the numerous experienced teachers and multitudes of textbooks who champion instrumental approaches to teaching and learning mathematics.

Assuming both types of understandings will remain in play for years to come, Skemp worries about three types of disparities that can arise: students for whom instrumental understanding is the only objective, taught by a teacher who wants them to understand relationally; students who want to understand relationally, taught by a teacher who teaches instrumentally (either by choice or by limitation); and the “less obvious mis-match ... which may occur between teacher and text” (Skemp, 2006, p. 90). After discussing why the latter mis-match is so problematic, especially with a procedural teacher and an innovative text, Skemp (2006) surprises his readers by actually conceding:

If pupils are still being taught instrumentally, then a ‘traditional’ syllabus will probably benefit them more. They will at least acquire proficiency in a number of mathematical techniques which will be of use to them in other subjects, and whose lack has recently been the subject of complaints by teachers of science, employers and others (p. 91).

Skemp gets the conversation going by listing the advantages of both instrumental mathematics and relational mathematics. “Instrumental mathematics”, he offers, “is usually easier to understand ... so the rewards are more immediate, and more apparent” (Skemp, 2006, p. 92). He mentions the feeling of success students can get from producing a page of correct solutions and reminds educators not to dismiss the importance of building student confidence. The final advantages Skemp mentions are efficiency and dependability. “Just because less knowledge is involved, one can often get the right answer more quickly and reliably by instrumental thinking than relational. This difference is so marked that even relational mathematicians often use instrumental thinking” (Skemp, 2006, p. 92). When

Skemp turns to the benefits of relational mathematics, he focuses on four main points: relational thinking is adaptable; it is simpler to recall (though more difficult to learn); relational knowledge, in and of itself, can be a target for students; and relational learning leads to more relational learning. Skemp (2006) expands on the fourth point:

If people get satisfaction from relational understanding, they may not only try to understand relationally new material which is put before them, but also actively seek out new material and explore new areas, very much like a tree extending its roots or an animal exploring a new territory in search of nourishment (p. 93).

The advantage listed above which resonates with me, personally, is the idea that relational understanding of a particular topic is often far easier to remember than instrumental understanding of the same topic. Skemp chooses to illustrate this idea by comparing finding the area of different polygons (triangles, parallelograms, trapezoids) using memorized formulas (instrumental) to finding the area of those same polygons by considering them all in relation to the area of a rectangle (relational). I think I was struck by this example in part because I had just taught this concept (relationally) the day before reading Skemp's article. While most students were receptive to this way of thinking, I did have one student who could still recall all of the necessary formulas from high school and immediately asked, "why don't you just do one-half base times height?" We were stuck in the precise mis-match Skemp had described 36 years earlier!

While teaching the Fractions for Welders unit, I hope to remain aware of my students' attitudes regarding their preferred method of learning. I will strive to engage students in activities which teach them what to do and which clarify the reasons for doing so. The first big hurdle in the unit will be helping students learn (or review, as the case may be) how to simplify a fraction. I am prepared to encounter students who are able to simplify fractions by dividing both the numerator and denominator

by the same quantity but who cannot explain why the resultant fraction is equivalent to the original fraction. I am hoping to clarify this process through my focus on versions of one (fractions such as $\frac{5}{5}$).

Kadijević (1999) carefully and elegantly makes the leap from Skemp's theories to actual classroom practice. He suggests researchers and educators should stop focusing on what he calls object-based *knowledge* and process-based *knowledge* (synonymous with relational understanding and instrumental understanding, respectively) and instead concentrate on the creation of conceptual tasks which can be used to effectively assess object-based thinking. He offers a variety of examples, including several which involve

objects that are not (fully) quantified, such as the following tasks for earlier secondary education:

1. Which number is bigger?
 - a. $a + 5$ or $4 + a$ (a is a whole number)?
 - b. $\frac{a}{b}$ or $\frac{2a}{3b}$ (a and b are natural numbers)?
 - c. x^{1997} or x^{2000} (x is a real number)? Consider all cases.
2. Prove that the sum of the distances from any point in the interior of an equilateral triangle to its sides is equal to the length of the triangle's altitude.
3. When is a number of the form ' $aabbba$ ' (a and b are some digits) divisible by 6? (Kadijević , 1999, p. 59).

He argues against "traditional mathematics teaching" which promotes skills over conceptual understanding, skills which are "primarily fostered through solving procedural tasks involving fully quantified objects, which students often solve by using ... rules (algorithms) without knowing why they work" (Kadijević , 1999, p. 59). He clearly explains the difference between procedural tasks which require computation without conceptual understanding and conceptual tasks which often involve very

little computation but a great deal of understanding. Kadijević cites a study of Calculus (Dreyfus & Eisenberg, 1990) which supports the realization “that mathematics education also needs to be based upon conceptual tasks, as they, contrary to traditional procedural tasks, can fully assess whether genuine understanding of the underlying domain is really achieved” (Kadijević , 1999, p. 62).

Kadijević also supports the use of technology in the classroom, describing how the introduction of computer-based mathematics instruction has the ability to change mathematics education in general. “This is because computers can be used to introduce a new balance of instructional time by decreasing the time for procedural skills and increasing the time for conceptual understanding, which seems to promote better understanding” (Kadijević , 1999, p. 62). When I read this, I immediately thought of some of my favorite instructional applets; specifically, several applets which allow the user to manipulate a right triangle while watching a visual proof of the Pythagorean Theorem. I remember classes where students who had previously memorized $a^2 + b^2 = c^2$ without relational (object-based) understanding began to truly grasp the meaning of that foundational theorem of geometry. If we, as a class, would have had to create dozens of right triangles and corresponding squares by hand in order to compare areas of those squares, there simply would not have been enough time to step back and see the proof as a whole. When technology can take over some of the procedural responsibilities, students and teachers are free to devote more time thinking, debating, and discussing on a conceptual level. Kadijević (1999) recommends further research directed towards several targets including generating sets of conceptual tasks for a variety of areas within the discipline of mathematics as well as creating valuable computer-based teaching techniques involving deciphering conceptual tasks.

A major aim of a 2010 study by Forrester and Chinnappan is to examine “with sufficient rigor” the two components of content knowledge, concepts and procedures (Forrester & Chinnappan, 2010, p. 185). In this study the terms conceptual and procedural are used instead of relational and instrumental, respectively. These researchers studied a group of pre-service teachers (n = 186) in their first year of a

teacher education program. Each teacher was asked to complete two problems. The first problem deals with subtracting fractions ($1\frac{2}{5} - \frac{5}{6}$) while the second deals with multiplying fractions ($\frac{1}{4} \times \frac{2}{3}$). Participants were given fifteen minutes to solve both problems and were “expected to show all steps, including any visual representations that could be used to demonstrate their thinking” (Forrester & Chinnappan, 2010, p. 187). Researchers analyzed each response looking for actual evidence of conceptual knowledge, procedural knowledge, or both; responses were scored on a scale from 0 to 4. Participants who earned a 4 provided a correct algorithm for solving the problem as well as a “model supported with language” (Forrester & Chinnappan, 2010, p. 187). A score of 4 meant the participant had provided evidence of conceptual knowledge with unambiguous reasoning. Unfortunately, the vast majority of students scored a 1 out of 4 on both tasks. Responses given a score of 1 reflected purely procedural knowledge (a correct algorithm). Less than half of the participants attained a score of 1 on the subtraction problem; this number jumped to just over 120 (roughly two-thirds of the group) for the multiplication problem. Amazingly, less than a third of the pre-service teachers provided no evidence whatsoever of procedural or conceptual understanding of the subtraction problem; in other words, they offered incorrect solutions. The most common errors are presented below.

Error A: $\frac{7}{5} - \frac{5}{6} \rightarrow \frac{7}{30} - \frac{5}{30} = \frac{2}{30} = \frac{1}{15}$; subtracting numerators and multiplying denominators.

Error B: e.g., $\frac{7x6}{5x6} - \frac{5x6}{6x5} = \frac{42}{30} - \frac{30}{30} = \frac{12}{30}$; an error in making equivalent fractions. There was a range of different mistakes within this group (Forrester & Chinnappan, 2010, p. 190).

Nearly 40 participants missed the multiplication problem, displaying neither procedural knowledge nor conceptual knowledge. The most common errors are shown here.

Error 1: $\frac{1}{4} \times \frac{2}{3} = \frac{3}{12}$; adding numerators and multiplying denominators.

Error 2: $\frac{1}{4} \times \frac{2}{3} = \frac{3}{12} \times \frac{8}{12} = \frac{24}{12} = 2$; making equivalent fractions and

multiplying the numerators (Forrester & Chinnappan, 2010, p. 190).

Forrester and Chinnappan conjecture that participants who made the mistake indicated in Error 2 might be incorrectly transferring knowledge regarding the addition and subtraction of fractions with unlike denominators. This is not to be unexpected for instrumental (procedural) thinkers, especially if the learner's knowledge was predicated solely on memorizing a method but not truly understanding the situation which calls for that method (Skemp, 2006).

Forrester and Chinnappan (2010) came to the conclusion that the overwhelming dominance of procedural over conceptual knowledge was present not only in the solutions provided by participants in their study but that this dominance was also apparent in the type of errors produced by participants. It is also interesting to note "none of the pre-service teachers made procedural or calculation errors while simultaneously demonstrating conceptual understanding in their models" (Forrester & Chinnappan, 2010, p. 191). The researchers are currently implementing Phase 2 of their project. Phase 2 will include a follow-up with the participants after they have completed some professional experience and more course work. More research is needed to explore the quality of content knowledge held by pre-service teachers because, as Forrester and Chinnappan explain, "teachers who develop content knowledge that is predominantly procedural cannot be expected to help children develop rich conceptual connections" (Forrester & Chinnappan, 2010, p. 191).

The ongoing discussion regarding procedural versus conceptual understanding in the academic world can also lend itself to an increased awareness of effective ways to teach specific subject matters as well as specific concepts (fraction division) within those subject matters (mathematics). Teacher understanding in the United States of division by fractions is frequently limited to an understanding of how to utilize the standard invert and multiply algorithm. Liping Ma's fascinating and thought-provoking book, Knowing And Teaching Elementary Mathematics, examines teachers' understanding of

fundamental mathematics in both China and the United States (Ma, 1999). The essence of the book is Ma's analysis of the type of understanding that sets apart the two groups of teachers. Chinese elementary teachers, having spent fewer years studying mathematics, have a far more profound understanding of the subject. Chinese teachers' conceptual knowledge tends to be more flexible and more adaptable to new knowledge. Ma scrutinizes teachers' approaches to a variety of problems in her book; I will focus on her analysis of teacher calculations and representations related to division of fractions.

Ma investigated teachers' knowledge of division by fractions. Teachers were requested to compute $1\frac{3}{4} \div \frac{1}{2}$ as well as to illustrate the meaning of the problem. The exact scenario she presented to 23 teachers from the United States and 72 teachers from China is presented below.

People seem to have different approaches to solving problems involving division with fractions. How do you solve a problem like this one?

$$1\frac{3}{4} \div \frac{1}{2} =$$

Imagine that you are teaching division with fractions. To make this meaningful for kids, something that many teachers try to do is relate mathematics to other things. Sometimes they try to come up with real-world situations or story-problems to show the application of some particular piece of content. What would you say would be a good story or model for $1\frac{3}{4} \div \frac{1}{2}$? (Ma, 1999, p. 55).

Only nine teachers from the United States (43% of the participants) were able to complete their computations and arrive at the correct solution. In contrast, every single teacher from China (100%) was able to supply a correct answer to the problem. Therefore, it is fairly straightforward to state Chinese elementary teachers have a better procedural grasp on dividing by fractions than their counterparts from the United States.

Ma's study becomes even more interesting, and the gap widens between Chinese teachers and United States teachers, when she examines the teachers' responses to the second part of the scenario. Teachers', we recall, were asked to create a story or model to represent the division problem $1\frac{3}{4} \div \frac{1}{2}$. While 43% of United States teachers were successful in calculating $1\frac{3}{4} \div \frac{1}{2}$, nearly all of them failed to create an adequate representation for the problem. According to Ma, "among the 23 teachers, 6 could not create a story and 16 made up stories with misconceptions. Only one teacher provided a conceptually correct but pedagogically problematic representation" (Ma, 1999, p. 64). Ma goes on to explain most of the teachers who created stories with misconceptions had confused $1\frac{3}{4} \div \frac{1}{2}$ with $1\frac{3}{4} \times \frac{1}{2}$ (or $1\frac{3}{4} \div 2$); most of these stories related to having $1\frac{3}{4}$ of something (usually circular food like pizza or pie) and needing to share it with two people. As a result, several teachers generated two different answers, $3\frac{1}{2}$ and $\frac{7}{8}$. Incredibly, of the nine teachers who had successfully calculated the answer ($3\frac{1}{2}$) using the invert and multiply algorithm, only five noticed that their stories had led them to a different answer ($\frac{7}{8}$)! None of the five were able to explain the discrepancy between their answers. Most simply gave up. So, although 43% of United States teachers were able to get the division problem right, "none showed an understanding of the rationale underlying their calculations" (Ma, 1999, p. 83).

In contrast, 90% of the Chinese teachers were able to produce a conceptually correct representation of the division problem $1\frac{3}{4} \div \frac{1}{2}$. Not only did a large majority of teachers from China generate a correct representation, they were able to do so in three different ways utilizing an astounding array of topics (only three of their representations involved circular food).

The Chinese teachers represented the concept using three different models of division: measurement (or quotitive), partitive, and product and factors. For example, $1\frac{3}{4} \div \frac{1}{2}$ might represent:

- $1\frac{3}{4}$ feet \div $\frac{1}{2}$ feet = $\frac{7}{2}$ (measurement model)
- $1\frac{3}{4}$ feet \div $\frac{1}{2} = \frac{7}{2}$ feet (partitive model)
- $1\frac{3}{4}$ square feet \div $\frac{1}{2}$ feet = $\frac{7}{2}$ feet (product and factors)

which might correspond to:

- How many $\frac{1}{2}$ -foot lengths are there in something that is 1 and $\frac{3}{4}$ feet long?
- If half a length is 1 and $\frac{3}{4}$ feet, how long is the whole?
- If one side of a $1\frac{3}{4}$ square foot rectangle is $\frac{1}{2}$ feet, how long is the other side? (Ma, 1999, p. 72).

While food and money comprised the foremost topics of the United States teachers' (incorrect) representations, the subjects used by the teachers from China were incredibly varied. Topics ranged from farming and factory work to bike riding and cooking. Their profound (conceptual) understanding of the meaning of division by fractions "provided them with a solid base on which to build their pedagogical content knowledge of the topic. They used their vivid imaginations and referred to rich topics to represent a single concept of division by fractions" (Ma, 1999, p. 78). Ma concludes by suggesting that a teacher absolutely must have relational understanding of a concept in order for him or her to present a "pedagogically powerful representation" to students (Ma, 1999, p. 83). Teachers in the United States have a long way to go in this regard.

According to Salinas (2009), pre-service teachers struggle with deep mathematical thought just as much as their more experienced counterparts. Salinas' 2009 study explored the quality of pre-service teachers' evaluations of student-generated algorithms for solving a variety of math problems. Evaluating another person's work, making a judgment based on a set of criteria, is considered to be an extremely high level skill (Bloom, 1956). Effective evaluations rely heavily on the evaluators'

prerequisite knowledge and skills at lower levels. According to Salinas, “if teachers are not equipped with the mathematical knowledge necessary to evaluate student work, they are less able to lead a class through an investigation that is anything but shallow” (Salinas, 2009, p. 33).

Participants (n = 61) in Salinas’ 2009 study were pre-service students taking an introductory course in mathematics education. Over the course of three semesters, Salinas presented several videotape clips of students performing algorithms in order to solve a variety of problems. Participants, after viewing the clips, evaluated the student work by writing journal responses. “Journal writings were to address the algorithm observed, and pre-service teachers were to consider and justify whether they would allow a student to use that algorithm in class” (Salinas, 2009, p. 29). Not surprisingly, the algorithm pre-service students had the most trouble evaluating dealt with division of a fraction by a fraction! “Thus, particularly with algorithms that involved fractions, pre-service teachers did not address the mathematical content directly in their journal responses. This suggests that they have less confidence in the mathematical content related to algorithms applied to fractions” (Salinas, 2009, p. 32). The most illustrative example Salinas provides in her article is a student-generated algorithm which calculates the correct answer to a fraction division problem but *conceptually* is deeply flawed. The student-generated algorithm and the traditional algorithm are both shown below.

$$\frac{a}{b} \div \frac{c}{d} = \frac{a}{b} \times \frac{d}{c} = \frac{ad}{bc}$$

Traditional

$$\frac{a}{b} \div \frac{c}{d} = \frac{b}{a} \times \frac{c}{d} = \frac{bc}{ad} = \frac{ad}{bc}$$

Student-Created (Salinas, 2009, p. 30).

Pre-service teachers struggled to evaluate this algorithm. Some suggested the extra step at the end (turning $\frac{bc}{ad}$ into $\frac{ad}{bc}$) was inefficient and they worried about how well this algorithm would serve the student in a future math class. Some praised the student; as long as the algorithm produced a correct answer, they were satisfied. Others questioned whether it would work for all cases, declared more

investigation was needed, but failed to actually explore the algorithm further. Salinas concludes, “encouraging pre-service teachers to investigate beyond the final answer is vital to teaching them to link conceptual understanding to the use of algorithms; challenging them with algorithms that are numerically correct but mathematically incorrect may motivate such investigations” (Salinas, 2009, p. 32).

Almost a decade prior to Salinas’ work, an interesting project by Tirosh (2000) produced some significant and similar results. Tirosh taught a mathematics methods course to students ($n = 30$) in their second year of a four year education program. These prospective elementary teachers happened to be 100% female. Throughout the course, Tirosh strived to answer two fundamental research questions: “Are prospective teachers aware of common difficulties that children experience with division of fractions? (*knowing that*) and To what do they attribute these difficulties? (*knowing why*)” (Tirosh, 2000, p. 8).

At the beginning of the study, each student (prospective teacher) completed a diagnostic questionnaire (Figure 1) and was personally interviewed by Tirosh.

Item 1. Following are four division expressions. You are requested to (a) calculate each of these expressions, (b) list common mistakes students in seventh grade may make, after finishing their studies of fractions, and (c) describe possible sources for each of these mistakes.

$$\frac{1}{4} \div 4; \frac{1}{4} \div \frac{3}{5}; 4 \div \frac{1}{4}; 320 \div \frac{1}{3}$$

Item 2. For each of the following word problems (a) write an expression that will solve the problem (do not calculate the expression), (b) write common incorrect responses, and (c) describe possible sources of these incorrect responses:

Problem 1: A five-meter-long stick was divided into 15 equal sticks. What is the length of each stick?

Problem 2: Four friends bought $\frac{1}{4}$ kilogram of chocolate and shared it equally. How much chocolate did each person get?

Problem 3: Four kilograms of cheese were packed in packages of $\frac{1}{4}$ kilogram each. How many packages contained this amount of cheese?

Figure 1 (Tirosh, 2000, p. 9).

Just five participants made errors while computing some of the division problems in Item 1. Two

participants gave an incorrect answer for the problem $\frac{1}{4} \div 4$. They “both wrote $\frac{1}{4} \div 4 = \frac{1}{4} \times 4 = 1$ ”

(Tirosh, 2000, p. 9). One prospective teacher solved $\frac{1}{4} \div \frac{3}{5}$ by inverting both the dividend and the divisor; she arrived at an answer of $6\frac{2}{3}$. The other two participants demonstrated a common misconception when solving the last problem; both came up with answers of 106.666... Participant answers to part (b) of Item 1 were typical. All of the prospective teachers were able to generate errors students may make when computing the four problems in question. However,

three participants wrote that students will mistakenly divide the

“tops and the bottoms”: $\frac{1}{4} \div \frac{3}{5} = \frac{1+3}{4+5}$. Although this response is

mathematically correct – $\frac{a}{b} \div \frac{c}{d} = \frac{a \div c}{b \div d} = \frac{\frac{a}{c}}{\frac{b}{d}} = \frac{\frac{a}{c}}{\frac{b}{d}} \times \frac{\frac{d}{d}}{\frac{d}{d}} = \frac{a}{c} \times \frac{d}{b} = \frac{ad}{bc}$

– prospective teachers offered the response as an example of an

incorrect way to solve $\frac{1}{4} \div \frac{3}{5}$ and, in a classroom setting, would

probably have considered it an error (Tirosh, 2000, p. 10).

Because Tirosh is not sure how the other participants would react to a student using this algorithm, he builds it into his study later on in the course. Before examining that portion of the research, though, it is important to take a closer look at the initial responses to part (c) of Item 1. All of the participants generate possible causes of student errors, but every reason is algorithmic in nature. Most discuss how students might not follow the steps of the traditional division of fraction algorithm correctly. “Generally speaking, the participants appeared to believe that the steps of the algorithm are memorized and that if a step is forgotten, students will be unable to reconstruct it through mathematical inquiry. The possibility of performing the division without using the standard algorithm (e.g., $4 \div \frac{1}{4} = 16$ because there are 16 quarters in 4) was not considered” (Tirosh, 2000, p. 10-11). In analyzing the results of the word problem portion of the questionnaire (Item 2), Tirosh found participants fell into two categories. A few of the prospective teachers seemed to be aware of the tendency children have “to attribute properties of operations with natural numbers to operations with fractions” (Tirosh, 2000, p. 12); the

majority of the participants appeared unaware of this tendency and therefore they “attributed students’ incorrect responses to algorithmic or reading-comprehension difficulties” (Tirosh, 2000, p. 12).

After analyzing the pre-test, Tirosh designed activities for his class. Some of the activities were specifically devised to address the correct algorithm participants had deemed incorrect during the diagnostic questionnaire. One such activity involved participants in groups discussing two specific scenarios (Figure 2).

Can Fractions Be Divided in an Easier Way?

1. You are discussing operations with fractions in your class. During this discussion, Ron says
It is easy to multiply fractions; you just multiply the numerators and the denominators. I think that we should define the other operations on fractions in a similar way:

Addition	$\frac{a}{b} + \frac{c}{d} = \frac{a+c}{b+d}$
Subtraction	$\frac{a}{b} - \frac{c}{d} = \frac{a-c}{b-d}$
Division	$\frac{a}{b} \div \frac{c}{d} = \frac{a \div c}{b \div d}$

How will you respond to Ron's suggestions? (Deal with each separately.)

2. Sally agrees with Ron and adds, "I don't understand why they decided to define addition, subtraction, and division in such complicated ways. Why didn't they decide to define the operations in the way that Ron suggested?" How will you respond to Sally's question?

Figure 2 (Tirosh, 2000, p. 14).

Most groups, after quickly dealing with the incorrect algorithms for addition and subtraction, tried to find a counterexample for the division algorithm. This leads to an incredible classroom discussion; even Tirosh is surprised by the level of interest and curiosity raised by this activity. In the end, the participants agree that Ron’s idea is correct but they would not opt to utilize it in all cases. Several prospective teachers admitted they would not know how to handle such an idea if it were to come up in class. “Sharon, for instance, commented, ‘Do students really ask such questions? That’s scary!’ Some admitted that they would probably reject such an idea because, as one said, ‘This is not the usual way we do it, and I will not be able to explore such an idea in class.’” (Tirosh, 2000, p. 17).

The in-class test at the end of the course contained the same two items from the pre-test; Tirosh was able to carefully examine and assess any changes in the prospective teachers' responses. Only one participant answered only one question wrong in Item 1. This particular student had also missed the question the first time around. Apparently, the class activities Tirosh designed for these students to address parts (b) and (c) were effective as well. "Twenty-eight participants provided more than one possible algorithmically based mistake for each expression. Also, 26 acknowledged specific intuitions related to fractions and to the operation of division as possible sources of incorrect responses" (Tirosh, 2000, p. 20).

To be clear, Tirosh is not advocating that teacher preparation courses and programs should require prospective teachers to learn about all of the common mistakes and misconceptions students have related to a wide array of topics. Rather, Tirosh suggests

teacher education programs familiarize prospective teachers with various, and sometimes erroneous, common types of cognitive processes and how they may lead to various ways of thinking. One such cognitive process is that of overgeneralization. During the course of this study, this cognitive process was discussed in the context of division of fractions, in reference to students' tendencies to attribute observed properties of division with natural numbers to fractions or properties of other operations on fractions to division of fractions. The data show that most participants assimilated this principle and were able to use it to foresee and interpret students' incorrect reactions to other related topics (Tirosh, 2000, p. 22).

Tirosh's analysis is one of the most clear and concise explanations for clarifying why students make the mistakes they do with regard to fraction division. Her ideas regarding how best to support and train

prospective teachers merit attention and praise. Her project “has shown that enhancing prospective teachers’ knowledge of children’s common conceptions of division of fractions is a demanding but achievable and important task” (Tirosh, 2000, p. 23).

Son & Crespo (2009) completed a study which extends the work of both Ma and Tirosh. “Both studies provide multiple insights about teachers’ ways of thinking about students’ non-traditional strategies when dividing fractions” (Son & Crespo, 2009, p. 241). Son & Crespo also researched prospective teachers’ responses to alternative algorithms, an “important resource in mathematics classrooms” (Son & Crespo, 2009, p. 242). However, Son & Crespo focused their study on one specific unorthodox strategy (the fraction division method $\frac{a}{b} \div \frac{c}{d} = \frac{a \div c}{b \div d}$). This algorithm “is not commonly taught or found in mathematics textbooks, particularly in North America where this study took place” (Son & Crespo, 2009, p. 236). Also, they included participants intending to become secondary teachers (n = 17) as well as participants planning to become elementary teachers (n = 17). It should be noted that prospective teachers were only included in this study if they signed the study’s consent form. Approximately 34% of future elementary teachers chose to participate while about 85% of eventual secondary teachers opted to be included.

The goal of the study was to comprehend the responses (and the reasoning behind the responses) of the prospective teachers. Son & Crespo placed emphasis on the interrelation between teacher’s knowledge, beliefs, and practices. More specifically, the research questions for this study were formulated as follows:

1. How do prospective teachers reason and respond to a particular student’s non-traditional strategy for division of fractions?
2. What factors influence their response to the student’s non-traditional strategy?

- (a) What do they say influenced their response?
- (b) What role, if any, did their beliefs about mathematics teaching and learning play in their response? (Son & Crespo, 2009, p. 242-243).

The researchers believed teacher reaction to a student-generated, non-traditional strategy would provide great insight into that teacher's ability to balance fostering his/her students' critical thinking skills with his/her own commitment to the mathematical content at hand. For the purpose of this study, Son & Crespo oversimplified previous research regarding different teaching approaches and decided to employ two broad categories of mathematics teaching methodologies throughout their study: student-centered and teacher-centered (Son & Crespo, 2009).

The central activity used in this study was directly adapted from the Tirosh (2000) research. The researchers used a teaching scenario to uncover participants' responses to an unorthodox method of dividing fractions. This task consisted of two prompts (Figure 3).

You are teaching division of fractions to 6th graders. You asked the students to solve $\frac{2}{9} \div \frac{1}{3}$. After a few minutes, you asked Dan, one of your students, to explain how to solve the problem. Dan says that he can divide fractions in a way that is similar to the way he multiplies fractions. He comes to the board and writes: $\frac{2}{9} \div \frac{1}{3} = \frac{2 \div 1}{9 \div 3} = \frac{2}{3}$. You ask the class what they think about this and whether they agree with Dan. Sally, one of the students, said that she doesn't agree and adds, "I don't get it. This is not the way we're supposed to divide fractions. The way to do it is to invert and multiply."

Part I.

1. How would you respond to Dan and Sally and why? Explain it in as much detail as you can.
2. Do you think Dan's strategy works for any problem? If yes, explain why. If no, explain why not.

Part II.

Look at your response to the scenario above and say a bit about what you think influenced the way you responded. Does your response connect with how you think about what doing mathematics entails? Does it connect with how you think about what good mathematics teaching is? And/Or does it connect with how you think about how students come to understand and be proficient with mathematics?

Figure 3 (Son & Crespo, 2009, p. 243).

The researchers were somewhat surprised to discover the majority of participants gave primarily teacher-centered responses to both fictional students, Dan and Sally. Considering all of the participants

were in the midst of a teacher education program which stressed the importance of encouraging students to justify and explain their thought processes, Son and Crespo were slightly alarmed at the number of prospective teachers who resorted to teacher-focused responses like “telling and explaining” (Son & Crespo, 2009, p. 253). 59% of the future elementary teachers used a teacher-focused response in his or her response while 82% of the potential secondary teachers went with this approach (Son & Crespo, 2009). The researchers were especially concerned about this finding because the prospective secondary teachers majoring in math, “those presumably in better position to recognize and use students’ non-traditional strategies as learning opportunities” were the least likely to do so (Son & Crespo, 2009, p. 254).

Son and Crespo are careful not to offer any generalizations based on their research study. Instead, due to the small number of participants and the singular activity involved they share what they refer to as “research insights” in lieu of hard and fast conclusions (Son & Crespo, 2009, p. 258). First and foremost, this study reinforces the importance for teachers *of* teachers to think through how to help their students (future teachers) learn to successfully use students’ unorthodox methods in their teaching. Secondly, “curriculum developers of K-12 and teacher-preparation texts might want to include non-traditional strategies associated with division of fractions and not solely [rely] on two traditionally emphasized strategies – invert and multiply and common denominator strategies” (Son & Crespo, 2009, p. 259). Finally, the study recommends more research investigating “prospective and also in-service teachers’ reasoning and responses to students’ thinking”, especially related to the use of non-traditional strategies (Son & Crespo, 2009, p. 259).

Teachers who are able to utilize alternative methods of division by fractions ultimately have a deeper relational understanding of the concept. Furthermore, teachers who are comfortable using (and evaluating) alternative methods will help produce students with a more profound relational understanding of fraction division. In Liping Ma’s (1999) comparative analysis of elementary teachers in

the United States and China, she highlights the flexibility with which Chinese elementary teachers are able to think about division by fractions. While most of the Chinese teachers did use the standard algorithm, many did not. In addition, many who used the standard algorithm offered at least one other way of calculating the answer to the problem $1\frac{3}{4} \div \frac{1}{2}$. Some used decimals to calculate $1.75 \div 0.5 = 3.5$.

Others used the distributive law (shown below):

$$\begin{aligned} 1\frac{3}{4} \div \frac{1}{2} &= \left(1 + \frac{3}{4}\right) \div \frac{1}{2} \\ &= \left(1 \div \frac{1}{2}\right) + \left(\frac{3}{4} \div \frac{1}{2}\right) \\ &= 2 + 1\frac{1}{2} \\ &= 3\frac{1}{2} \quad (\text{Ma, 1999, p. 62}). \end{aligned}$$

Still others chose to divide $\frac{7}{4}$ by $\frac{1}{2}$ simply by dividing the numerators and then dividing the denominators:

$\frac{7 \div 1}{4 \div 2} = \frac{7}{2} = 3\frac{1}{2}$. To her credit, Ma admits she had never seen this approach used before seeing it done by a teacher in her study (Ma, 1999, p. 64). This specific teacher obliged Ma during the study and deduced a simple proof for her to justify his calculation. The Chinese teachers, collectively, contended that their students should be able to know multiple methods for solving a given problem *as well as to determine which method makes the most sense to use for a specific question*.

Sharp and Adams (2002) found that fifth-grade students, given the right conditions, were able to generate the common denominator algorithm for solving division, representing a “manifestation of conceptual knowledge about addition and subtraction of fractions and a definition of division” (Sharp & Adams, 2002, p. 333). The steps for solving $\frac{a}{b} \div \frac{c}{d}$ using this alternative algorithm would be to first recognize the problem can be restated as “How many times can $\frac{c}{d}$ be subtracted from $\frac{a}{b}$?” Since subtraction requires the solver to rewrite the divisor and the dividend as equivalent fractions with common denominators, $\frac{a}{b} \div \frac{c}{d}$ would become $\frac{ad}{bd} \div \frac{bc}{bd}$. At this point, the problem essentially turns into a

whole number division problem: “How many times can bc be subtracted from ad ?” The answer, of course, is $\frac{ad}{bc}$.

Sharp and Adams (2002) worked with a class of 23 fifth-graders whose prior experience with fractions was sound but limited to finding equivalent fractions, adding and subtracting fractions, and converting from improper fractions to mixed numbers (and vice versa). It is important to note these students also had exhibited skill at whole number division. They also knew multiplication facts. Sharp and Adams constructed and ordered 20 rich, real-word problems in order to expose the fifth-graders to division by fractions. An example of such a problem is shown below.

Problem with large dividend and thirds:

When I got home last night, I found my dog not feeling very well. So, I took her to the veterinarian.

Our vet said to give our dog some medicine. She gave us 15 tablets.

Because our dog is very large (100 pounds), the vet said to give the dog $1\frac{1}{3}$ tablet each day. For how many days will the medicine last? (Sharp & Adams, 2002, p. 339).

The researchers felt it was important to include photographs for each content-rich problem they designed. Sharp and Adams contend that context is important to student learning for three main reasons: context motivates students; context allows researchers to ask more meaningful questions, offering a “window into conceptual understanding” of the students (Sharp & Adams, 2002, p. 344); and context allows students to avoid common hang-ups with regard to fraction division. For example, students were never stumped wondering how a quotient could possibly be larger than the dividend.

Throughout the sequence of real-world problems, two symbolic-only problems were also presented to students such as “What does $6 \div \frac{3}{8}$ mean?” Two student responses to this context-free question are shared below.

Hannah responded “How many three-eighths are in six.” Other

students became more comfortable abandoning images to make hefty use of symbols. Michael suggested, “Just write $\frac{3}{8} + \frac{3}{8} + \frac{3}{8} + \dots$ until we get 6 wholes.” It may well be the case that some of these students may have visualized their own contexts or drawn their own mental pictures. For some of them, this symbolic-only exercise produced some symbolic-only answers and explanations (Sharp & Adams, 2002, p. 343).

Teaching with realistic situations is an effective way to help students move from a conceptual understanding of problems with rich context to a conceptual understanding of symbolic-only problem. Students are able to invent procedures that are efficient and mathematically valid; however, because of their teachers’ intentional approach to instruction, *their procedures remain rooted in conceptual understanding*.

Some very positive research exists involving a group of students over two years (5th and 6th grade) who were never taught any formal algorithms for dividing by fractions (Bulgar, 2009). Amazingly, these students were still able to develop a very meaningful grasp of the concept, an understanding that was proven to be durable over time. In lieu of formal algorithmic instruction, students experienced some extensive problem solving involving fractions during which they were encouraged to use manipulatives (Unifix Cubes®, pattern blocks, Cuisenaire Rods®, graph paper, meter sticks, string, scissors). After this, 5th grade students were asked to complete an activity called Holiday Bows (Appendix A) over the course of two class periods. The following year, the same students (now 6th graders) were asked to work on an activity called Tuna Sandwiches (Appendix B). For the 5th grade Holiday Bows task, the teacher provided students with ribbons, meter sticks, string and scissors. Remember, this task was the students’ very first brush with fraction division. A class discussion followed the activity. A week later, students were presented with three problems involving division by fractions.

These problems were presented in symbolic form only; no real-world context was offered to accompany the following:

- $5 \div \frac{1}{3}$
- $12 \div \frac{3}{4}$
- $7 \div \frac{2}{3}$

Remarkably, every student was able to produce correct solutions, leading Bulgar to assert there was evidence of all of the following within the 5th grade class:

- Solving division of fractions problems within a concrete context.
- Solving division of fractions problems using symbolic notation.
- Understanding of the inverse relationship resulting in a decreased quotient when the dividend is increased.
- Understanding that the quotient is a count of how many times the divisor can be measured along the dividend.
- Understanding that the operation of division for fractions has the same meaning as the operation of division in natural numbers so that one can fluidly move between these two forms to get the same solution.
- Even when a procedure for division of fractions is described it is rooted in the understanding of the conceptual basis for why this works. Not all students conceptualized the procedure in the same way.

- Even when students did not draw representations, their explanations provide clues to the internal models they used to solve problems (Bulgar, 2009, p. 185-186).

After the Tuna Sandwiches activity in 6th grade, which was just as successful as the Holiday Bows task, students were again asked to solve two problems represented purely in symbolic form:

- $2 \div \frac{3}{4}$
- $\frac{5}{8} \div 2\frac{1}{2}$

Yet again, all of the student solutions suggested a relational understanding of the concept. The Bulgar study is important research because it reminds educators and researchers alike that students can form connections and relational knowledge, while avoiding the typical difficulties related to a deep understanding of fractions, on their own as long as certain conditions are present. Appropriate activities and classroom climate are vital, as well as significant time. Finally, teachers need to be willing to invest energy into building “a deep understanding of students’ representations in order to choose and design appropriate tasks that become concrete contexts for the development of abstract ideas about division of fractions” (Bulgar, 2009, p. 195).

Newton and Sands (2012) focused on alternative methods that can be used to divide fractions. The article focuses on an important question related to an alternative method used to divide by fractions: “Why not just divide across?” Herein lies the essence of my entire curriculum project. According to Newton and Sands, “by not addressing this question before guiding students to a standard approach, students’ sense of what is reasonable may be undermined” (Newton & Sands, 2012, p. 342). Newton and Sands worked with a teacher and class of sixth-graders ($n = 11$) to study how to help students move from an intuitive understanding of a student-generated algorithm (which works well in some cases) to a relational understanding of a more standard algorithm (which works well in all cases). Essentially, by allowing students to use the dividing across method until a *student* points out its

limitations, teachers can generate motivation for discovering a better method; students are primed for carefully building the invert and multiply method instead of having it forced upon them as a rule to memorize.

When asked to conjecture about dividing fractions, students in this class used their prior knowledge of fraction multiplication to develop a divide across method. But as they realized that this method was not always easy, they were eager to explore alternatives. Eventually ... several students demonstrated flexible knowledge of division and shifted from one method to another depending on the particular circumstances (Newton & Sands, 2012, p. 344-345).

In an educational setting where it is often extremely difficult to determine the level of student understanding (procedural vs. conceptual), it is wonderful to see students doing mathematics flexibly and adaptably. Students who easily and confidently demonstrate how to solve a problem in various ways are clearly demonstrating conceptual understanding.

Several fundamental themes emerged throughout my review of the literature: nurturing relational (conceptual) understanding over instrumental (procedural) understanding remains a subject of vital significance for both teachers as well as researchers; U.S. elementary teachers' understanding of fraction division is lacking; and people who are able to flexibly use various methods when dividing by fractions possess a more profound conceptual understanding of this complex arithmetic operation. In Skemp's words, they know "both what to do and why" (Skemp, 2006, p. 89). Helping students achieve such a deep understanding of mathematics should be a goal of anyone developing curriculum; even more so, it appears, if the unit involves fractions. The Fractions for Welders curriculum begins with an increased emphasis on comprehending the two components of a fraction, creating equivalent fractions, and simplifying fractions. Care is taken to establish a solid foundation related to fractions before moving

into a study of operations with fractions. This groundwork sets the stage for students to easily move into multiplying and dividing fractions. Addition and subtraction are saved for later; this is a significant departure from traditional curriculums. Also, students will be encouraged to generalize the standard multiplication algorithm to division. It is hoped allowing this procedure may encourage the mathematical flexibility often linked to deep conceptual understanding in students.

Chapter 3

Methods

This project involves a unique method for helping students conceptually understand fractions as well as how to perform basic operations with fractions. Fraction division is an area of focus but the scope of the project extends beyond this one operation. The purpose of the project is to analyze the effectiveness of a distinctive curriculum, originally developed for seventh graders, when modified and implemented in a technical college classroom containing second-semester welding students.

Fractions for Welders was created as one of several units to be taught to a group of 14 students in the spring of 2012. Two of the 14 students were minors under the age of 18 and participated in the unit but are not referenced in this paper. The remaining 12 students were all male. Ten of the participants were enrolled in the Welding technical diploma program at Wisconsin Indianhead Technical College (WITC). One student was enrolled in the Motorcycle, Marine, and Outdoor Power Products Technician technical diploma program; the remaining student had not yet declared a program of study.

The class met twice per week (Tuesdays and Thursdays) for 80 minute sessions. The Fractions for Welders unit was intended to require five class periods; this is the equivalent of ten 40 minute sessions (a two week unit in middle or high school). Care was taken to use all 80 minutes wisely with a goal of including at least five transitions (from one activity to another) per class period. Several activities were planned for each session; the belief being that adult learners need to change gears as often as their younger counterparts.

Each lesson plan is loosely outlined using Madeline Hunter's lesson plan design for direct instruction. She suggests each lesson should include the following components: anticipatory set; objective; input; modeling; guided practice; independent practice; closure (Hunter, 1982). Personally, closure is an area I struggle with professionally. Even my best lessons often end with students doing

independent practice; classes are rarely brought back together for a summary or review of the objectives from the day. I attempted to include a closing activity with each lesson in the Fractions for Welders unit as a matter of professional development.

About a week prior to the start of the Fractions for Welders unit, a pre-test (Appendix C) was given to the students. I wanted to have a chance to adjust activities and lesson plans accordingly if I saw anything extraordinary (for example, evidence suggesting a need to review some prerequisite knowledge).

Lesson One

Anticipatory Set 1

Generally speaking, a new unit in one of my classes begins with an error analysis of the previous unit test. The Fractions for Welders class is no different. Therefore, the first activity to complete is to analyze the common and/or interesting mistakes from the previous unit. In this case, there were four problems from the previous test to be examined and discussed (one at a time) in a PowerPoint presentation. Following the error analysis, the tests are handed back to students. I rarely have students who feel the need to debate an answer or to argue for more points after a test; I have already addressed most of the questions they would have had via the error analysis in class. This has proven to be an effective learning tool as well as a time saver. I have learned this does not work, however, if tests are handed back before attempting to examine errors as a class!

Anticipatory Set 2

In this activity, students write fractions to represent portions of a fictional town. Students are paired up and given a worksheet containing a simple map (Appendix D). This exercise serves as an introduction to our study of fractions as well as a collaborative pre-test. This type of problem will appear two more times during the course of the unit; student progress should be clear. The map of the

fictional town is projected onto the screen in front of the classroom as well; allowing for class discussions throughout the activity as well as after the activity. At some point, pairs of students will need to divide the town into equal-size pieces so the fraction each resident owns can be easily named. If a pair of students does not come up with this idea on their own, the idea should be gently proposed by the teacher to facilitate their learning. When groups have finished, results should be summarized as a class, using the PowerPoint map as a guide.

Unit Objectives & Lesson One Objectives

At this point, using PowerPoint, the learning targets (Appendix E) for the unit are shared with students. These seven objectives are carefully written from the point of view of the student. A timeline for the unit is also presented (Figure 4).

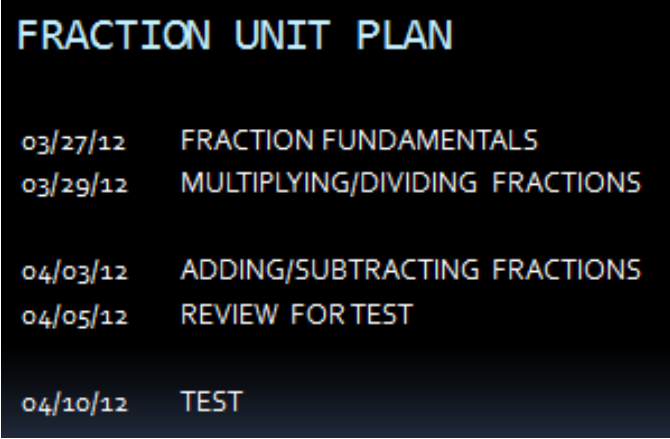

FRACTION UNIT PLAN	
03/27/12	FRACTION FUNDAMENTALS
03/29/12	MULTIPLYING/DIVIDING FRACTIONS
04/03/12	ADDING/SUBTRACTING FRACTIONS
04/05/12	REVIEW FOR TEST
04/10/12	TEST

Figure 4

Finally, it is important to reiterate which learning targets will be covered in Lesson One:

- I can find equivalent fractions by multiplying a given fraction by a "version of 1".
- I can simplify a given fraction by dividing it by an appropriate "version of 1".
- I can rewrite a mixed number as an improper fraction (and vice versa).

Input & Modeling & Guided Practice

Basically, the new information about fractions in general (fraction fundamentals) is presented in the form of a “Top Ten” list in PowerPoint form. The first of the “TOP TEN THINGS YOU NEED TO KNOW ABOUT FRACTIONS” is that there are two major ways to think about fractions (Figure 5).

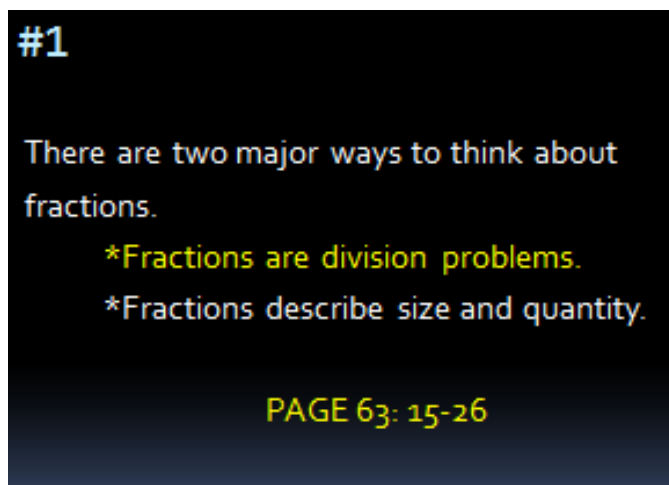

Figure 5

They can be division problems and they can also be descriptors of size and quantity. The first guided practice students will have will require them to utilize the conceptual (I hope) knowledge that the fraction bar is another way to write “÷”. Since this is knowledge students should have from earlier in the course, a quick review is all that should be required. Students will solve 12 problems from their textbook (Ewen & Nelson, 2010). Four sample problems are shown below. Students are asked to change each fraction to a decimal:

$$\frac{11}{15} \quad \frac{17}{50} \quad \frac{128}{25} \quad \frac{603}{24}$$

When students have completed the 12 problems, they should have the opportunity to check their answers; one slide in the PowerPoint presentation is devoted this.

Number two in the list is actually the second half of the first slide (Figure 6). Fractions describe the size of a piece (the denominator gives us this information) and the quantity of the pieces (the numerator gives us this information).

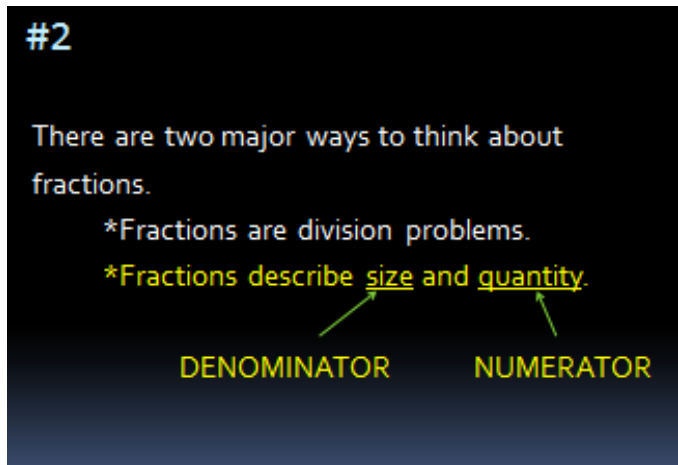

Figure 6

At this point, references to the fictional town from the anticipatory set are helpful and relevant. It is also to examine some fraction examples generated by students. This is also the time to discuss and warn students about an intuitive discrepancy they may encounter. It is still difficult for many students to conceptually understand that large denominators are tied to small denominations while small denominators are tied to large denominations. I like to have paper plates (already cut into specific denominations) ready for this discussion. I also find it is helpful for students to see extreme examples ($\frac{1}{2}$ vs. $\frac{1}{1,000}$, for example. I also use the scenario, “If a kindergartner walked in and saw us write $\frac{1}{2} > \frac{1}{1,000}$ on the board, what would she say? How could you prove to her this is actually true?”

The third important thing to know and understand about fractions is there are many different ways to write the whole number one. This is the most important piece for students to internalize. Guided practice here involves a large group brainstorming activity. Students are responsible for writing at least one unique version of one on the board in front of the room. Eventually, the entire board will be filled with great examples (not all involving fractions). Here are some common examples students come up with quickly:

$\frac{2}{2}$ $\frac{3}{3}$ one $\frac{1,000,000}{1,000,000}$ $\frac{1}{1}$ 2-1 $\frac{44}{44}$

At this point, it is important to examine several of the fractions through the lens of size and quantity as well as division. Ask questions like: “How would you prove that $\frac{44}{44}$ equals one?” and “What size pieces do we have here? How many of them do we have?” while pointing to a specific fraction. Asking for a proof is a great way to review #1 and #2 on the list. $44 \div 44 = 1$ and 44 44ths is also equal to a whole. I also like to add a few of my own versions of one to the board. My versions of one usually look like this:

$$\frac{12 \text{ in.}}{1 \text{ ft.}} \quad \frac{1 \text{ ft.}}{12 \text{ in.}} \quad \frac{1,000 \text{ mm.}}{1 \text{ m.}} \quad \frac{1 \text{ mile}}{5,280 \text{ ft.}} \quad \frac{2.54 \text{ cm.}}{1 \text{ in.}}$$

Once students have had a chance to digest these rates which equal one, they will begin suggesting their own. This is a great way to lay the foundation for lessons involving unit conversions in the future.

Number four on the list is another extremely important thing for students to understand about fractions (Figure 7).

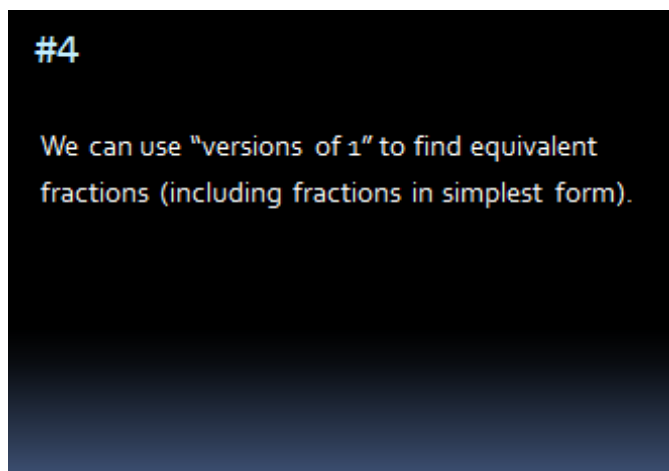

Figure 7

Basically, I will model how to find an equivalent fraction *while justifying my actions using the multiplicative identity*. I will ask for an example of a fraction from the students and proceed to highlight all of the resulting equivalent fractions which can be created by multiplying the example fraction by the versions of one which are still on the board. “Whose version of one should we use?” Again, it is important to ask questions like, “How could we prove that $\frac{3}{5}$ is equivalent to $\frac{132}{220}$?” With any luck, students will be able to articulate something like, “We multiplied $\frac{3}{5}$ by $\frac{44}{44}$ and since that is the same as

one, the answer we found has to be equal to $\frac{3}{5}$." Finally, division by a version of one will also need to be addressed. Students may need to be guided to the realization that although *any* version of one can be used when multiplying to create an equivalent fraction, more care must be taken when dividing by a version of one to create an equivalent fraction (if the goal is a whole number numerator and a whole number denominator). Remember, the learning target is expressed as "I can simplify a given fraction by dividing it by an *appropriate* version of one". At this point, present the following three problems to students (guided practice):

- Create three equivalent fractions to $\frac{4}{6}$.
- Find the equivalent fraction to $\frac{60}{96}$ that is expressed in simplest form.
- Create three equivalent fractions to $\frac{7}{x}$.

Because I wholeheartedly agree with Kadijević's ideas regarding fully quantified tasks (Kadijević, 1999), I plan to include expressions throughout the Fractions for Welders unit that are not fully quantified (like $\frac{7}{x}$ above). When students are ready to share their results, discuss student solutions and offer new problems if necessary.

The last item on the list to be covered in Lesson One is #5 (Figure 8). Mixed numbers (numbers including a whole number and a fraction) are not scary. Tim and Moby can prove it.

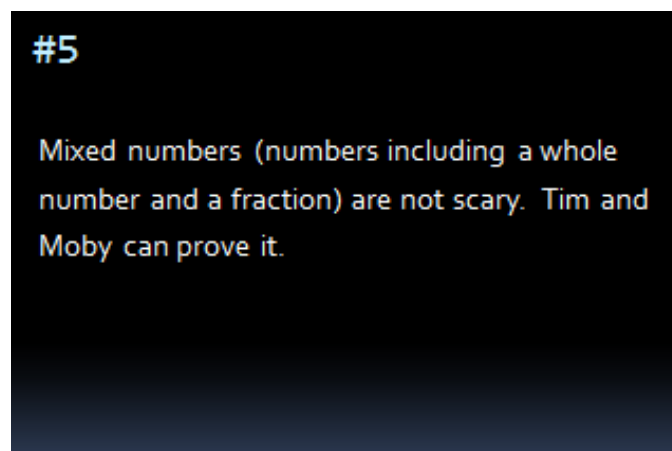

Figure 8

Tim and Moby are characters in a series of short movies on the website www.brainpop.com. Founded in 1999, BrainPOP creates animated, curriculum-based content that engages students, supports educators, and bolsters achievement. The BrainPOP animated movie shown during Lesson One is a terrific introduction to mixed numbers and how they related to improper fractions. After the movie, students will take the BrainPOP quiz as a class for guided practice. It is ten questions long and multiple-choice (Appendix F).

Closure

At this point, the five important concepts covered in the lesson should be reviewed. Then, working in pairs, students will complete the exit slip for the day. An exit slip is a task a student must complete and have approved before leaving the room. In this case, the exit slip is a worksheet with problems taken from Math for Welders (Marion, 2006). Students are asked to rewrite nine different mixed numbers as improper fractions; they are also asked to simplify six fractions. For example, students will need to rewrite $10\frac{10}{10}$ as 11 and they will need to rewrite $\frac{64}{656}$ as $\frac{4}{41}$ (Marion, 2006). This is an excellent chance to see which students have grasped the concepts from the day and which students are still struggling. It also offers a nice way to talk with students to see whether they have purely procedural knowledge of the concept or whether they have a more relational understanding.

Independent Practice

Due to the fact students are required to buy their textbook, I feel obliged to use it as much as possible to justify their expense (Ewen & Nelson, 2010). As a result, the independent practice following Lesson One is several problems from their textbook (Figure 9). Problems directly address the learning targets associated with Lesson One.

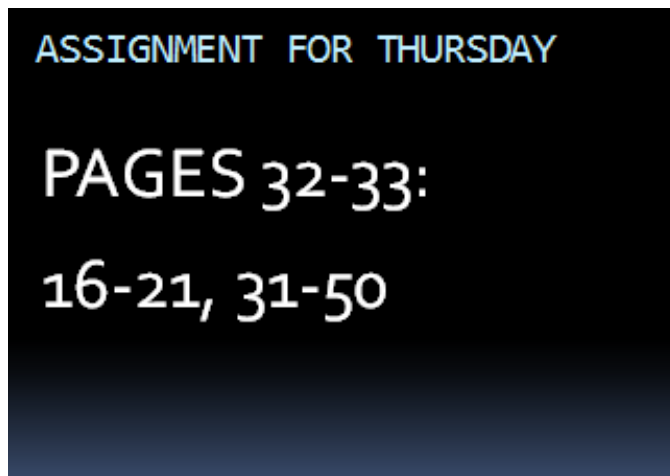

Figure 9

Lesson Two

Anticipatory Set 1

Lesson Two begins with the Fly Swatter Game. The class will divide into two teams and get into single-file lines facing the screen in the front of the room. The first person in each line will be given a fly swatter. A PowerPoint slide (Figure 10) will be projected onto the screen.

FLY SWATTER GAME			
$5\frac{1}{2}$	$3\frac{1}{2}$	$1\frac{5}{8}$	$2\frac{3}{8}$
	$6\frac{1}{2}$	$10\frac{3}{8}$	$4\frac{2}{3}$
$1\frac{1}{2}$	$2\frac{5}{8}$	$4\frac{1}{2}$	$1\frac{2}{5}$
	$11\frac{1}{2}$	$1\frac{2}{3}$	$2\frac{1}{2}$
$3\frac{5}{8}$	$1\frac{3}{8}$	$3\frac{2}{3}$	not here

Figure 10

The screen will be covered with various mixed numbers as well as the phrase “not here”. As the instructor reads an improper fraction out loud, the two people holding the fly swatters attempt to find

the corresponding mixed number on the screen. The first person to slap the correct number on the screen wins that round. Both people then hand their fly swatters to their teammate (the next person in line) and head to the back of their respective lines. This game can be scored in a variety of ways. Most of the time I like to do a few practice rounds and then start an elimination round during which only the winner of a problem gets to stay in line; the loser sits down in his seat. The ultimate winner is the last person standing. This game will serve to review one of the learning targets from this unit as well as get students in the right mindset for math class.

Anticipatory Set 2

Next, students will have an opportunity to ask questions on the assignment from the previous class. Problems will be worked out, if requested. When all students are satisfied, the assignment will be collected.

Lesson Two Objectives

- I can multiply fractions.
- I can divide fractions (even if I have to use "Plan B").

Input & Modeling & Guided Practice

Lesson Two picks up where Lesson One left off. The "TOP TEN THINGS YOU NEED TO KNOW ABOUT FRACTIONS" PowerPoint presentation begins today with #6: "Of" means times (and times means "of"). This portion of the lesson focuses on multiplication and students' intuitive knowledge of fraction multiplication. All students are given a brownie (Little Debbie© Cosmic Brownies work great if time does not allow for homemade treats), a napkin, and a plastic knife. This activity will introduce students to the area model as a way to represent finding a fraction of (times) a fraction. Square brownies offer a natural context for introducing students to an area model for fraction multiplication. As a class, we will work through the following problems (these are guidelines; problems may differ when this lesson is implemented, depending on the direction students take the activity):

QUESTION POSED BY INSTRUCTOR	STUDENT ACTION	CORRESPONDING MATH PROBLEM
What is one-third of one whole brownie?	Students will cut their brownies into thirds and hold up one-third. Most will do this by making two vertical cuts. Some will make three cuts and will end up with an isosceles triangle and two trapezoids. It is good to have extra brownies on hand for teachable moments like this.	$\frac{1}{3} \times 1$
What is one-third of one-third of a brownie?	Students will cut their third into thirds and will hold up one-ninth.	$\frac{1}{3} \times \frac{1}{3}$
Show me two-thirds of one-third of a brownie. How can you describe this piece?	Students will cut and hold up two-ninths (and hopefully say, "two-ninths").	$\frac{2}{3} \times \frac{1}{3}$
What is one-half of three-fourths of a brownie?	Students will cut into their second brownie (Little Debbie® Cosmic Brownies come in pairs) for more practice problems.	$\frac{1}{2} \times \frac{3}{4}$

The multiplication problems and solutions will be recorded on the board as the class works its way through the brownie activity. A quick summary discussion can happen when students are either out of brownies or tired of dissecting them. Prompts will include (but are not limited to):

- “We won’t have brownies available every time we have to multiply a fraction by a fraction.”
- “How could we have solved these problems without cutting up some brownies?”
- “Remember, we’re already experts at multiplying by fractions; we’ve been multiplying by ‘versions of one’ since our last class!”

Students are often surprised to discover how well they can already solve fraction multiplication problems in their heads; specifically, finding fractional parts of whole numbers. Taking a minute after the brownie activity to place some emphasis on mental math is a great way to build confidence in students. A natural progression of questions is shown below.

- “What is $\frac{1}{2} \times 30$ or one-half of thirty?”

- “How about $\frac{1}{10} \times 50$ or one-tenth of fifty?”
- “If one-tenth of fifty is five, what do you suppose three-tenths of fifty equals?”

Eventually, most students will even be able to estimate products where the whole number is not divisible by the denominator of the fraction. For example, students will see $\frac{2}{3} \times 25$ and realize $\frac{2}{3} \times 24$ will be a decent estimate. Since $\frac{1}{3} \times 24 = 8$, $\frac{2}{3} \times 24 = 16$. So, $\frac{2}{3} \times 25 \approx 16$.

Now, the class is ready for #7: When dividing with fractions, you’ve got to have a PLAN B. At this point in the lesson, I will ask for students’ undivided attention for eight minutes. Students are always willing to concentrate intensely for a finite amount of time, especially if they are told in advance how long their focus will be required. It also seems to help if the amount of time is less than ten minutes! I like to project an online stopwatch count down (<http://www.online-stopwatch.com/>) onto the screen in front of the room to keep myself accountable and on track. In eight minutes, I will present the following information:

- Mixed numbers need to be converted into improper fractions before using the multiplication algorithm students are already comfortable with.
- I remind students they already know how to divide by a fraction; they have been dividing by “versions of one” in order to simplify fractions since the previous class.
- I explain mixed numbers also need to be converted into improper fractions before using the division algorithm they have learned.
- I present problem after problem where the algorithm holds up. For example, $\frac{4}{15} \div \frac{2}{5}$, $\frac{5}{16} \div \frac{1}{8}$, and $\frac{21}{20} \div \frac{3}{10}$. In each of these problems, the numerator of the dividend is divisible by the numerator of the divisor and the denominator of the dividend is divisible by the denominator of the divisor.
- Inevitably, a student will interrupt! It is important to wait until this happens (even though it is hard to do when you are on the clock). Sometimes students will generate a new problem where the

numerator of the dividend is not divisible by the numerator of the divisor or the denominator of the dividend is not divisible by the denominator of the divisor (or both). Other times students will focus on a sample problem presented by the instructor (for example, $\frac{21}{20} \div \frac{3}{10}$) and ask, “What if that three was a four?”

- At this point, if appropriate, we will discuss how to handle decimal numbers that end up in the numerator or denominator of the quotient (I will call a time out and stop the online stopwatch if we address this option). Basically, though, the class has been primed and is ready to hear about an algorithm that always works: “PLAN B”.
- It does not take much to convince students that dividing by a number is the same as multiplying by its reciprocal. Problems like $10 \div 2$ and $10 \times \frac{1}{2}$ will usually be needed.

When the timer runs out I will offer students a few warnings; I will run through some of the common mistakes people make while using “PLAN B”. Hopefully, this will prevent errors as well as reduce embarrassment for students when similar mistakes occur in class. The three errors I will address are

outlined in these problems: $\frac{2}{3} \div \frac{5}{4} = \frac{3}{2} \times \frac{5}{4} = \frac{15}{8}$ (using the reciprocal of the dividend instead of the

divisor); $\frac{9}{10} \div \frac{7}{11} = \frac{10}{9} \times \frac{11}{7} = \frac{110}{63}$ (using the reciprocal of both the dividend and the divisor); and

$3\frac{1}{7} \div 1\frac{4}{5} = \frac{22}{7} \times \frac{5}{9} = \frac{198}{35}$ (changing mixed numbers into improper fractions and forgetting to invert the divisor).

Number eight will not be new information to students. That being said, it is still important enough to warrant attention: When multiplying and dividing fractions, remember to change whole numbers and mixed numbers into improper fractions (Figure 11).

#8

When multiplying and dividing fractions, remember to change whole numbers and mixed numbers into improper fractions. Watch Tim and Moby demonstrate!

Figure 11

At this point, students are ready for another short video clip from www.brainpop.com. This clip teaches students to multiply and divide fractions. I think it is important for students to hear and see how to solve problems from people other than just their instructors; classmates and electronic media are two great alternative sources of information and learning. After the two minute video, students will again take the BrainPOP quiz for guided practice. It contains ten items and is multiple-choice (Appendix G).

The last bit of guided practice in Lesson Two will be a station activity. Problems pulled from Practical Problems in Mathematics: For Welders will be used (Chasan, 2009). Seven problems involving either fraction multiplication or fraction division will be placed throughout the room. Students will be encouraged to move through the stations at their own pace but to work together with other students while at the same station. The seven problems are listed below; all but two have accompanying illustrations which seem to be extremely helpful for students (Figure 12).

1. If 5 pieces of steel bar each $6\frac{1}{2}$ " long are welded together, how long will the new bar be?
2. A welder has an order for 8 pieces of angle iron, each $7\frac{1}{4}$ " long. What is the total length of the angle needed to complete the order? Disregard waste per cut.
3. This piece of angle is to be used for an anchor bracket. If the holes are equally spaced, what is the measurement between hole 1 and hole 2?
4. To weld around this weldment, $16\frac{1}{2}$ arc rods are needed. If $6\frac{3}{4}$ of the weldments are completed in an 8-hour shift, how many arc rods will be needed?

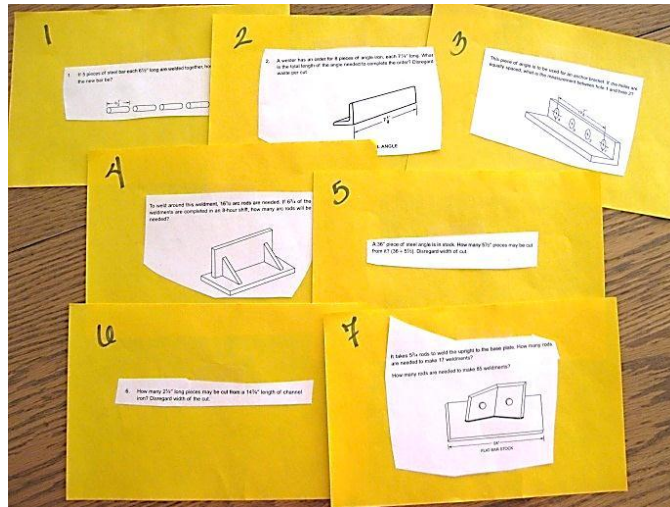

Figure 12

5. A 36" piece of steel angle is in stock. How many $5\frac{1}{2}$ " pieces may be cut from it? ($36 \div 5\frac{1}{2}$).
Disregard width of cut. * NO ILLUSTRATION *
6. How many $2\frac{1}{4}$ " long pieces may be cut from a $14\frac{3}{4}$ " length of channel iron? Disregard width of the cut. * NO ILLUSTRATION *
7. It takes $5\frac{3}{4}$ rods to weld the upright to the base plate. How many rods are needed to make 17 weldments? How many rods are needed to make 85 weldments?

When students have finished, we will review each problem and solution as a class. I am hoping to prevent most mistakes as I move through the room during this activity. This will also give me a chance to work closely with students who appear to be struggling with the concepts.

Closure

Technically, reviewing the problems from the station activity will be part of the overall closure for Lesson Two. In addition, students will be asked to complete a short (anonymous) survey related to their past experiences with and attitudes toward rational numbers. Providing this valuable insight will be their exit slip for the day (Appendix H).

Independent Practice

Again, because students are expected to buy their textbook, I feel compelled to use it as much as possible to validate their purchase (Ewen & Nelson, 2010). The independent practice following Lesson Two is an assignment related to the learning targets associated with this lesson (Figure 13).

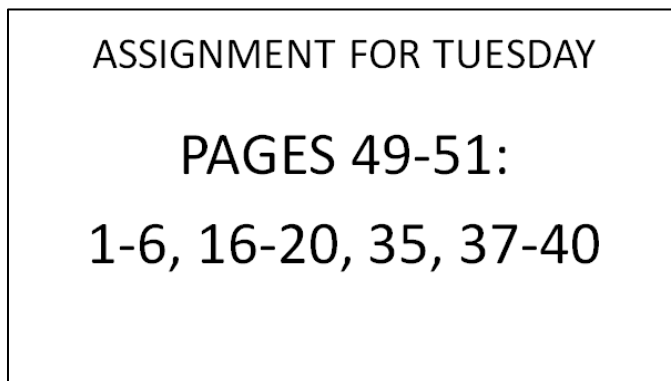

Figure 13

Lesson Three

Anticipatory Set 1

The opener for Lesson Three is similar to the Holiday Bow problem discussed in the literature review (Bulgar, 2009). Each student will be asked to take two pieces of licorice, a ruler, a napkin, and a knife (borrowed from the cafeteria). The purpose of the activity is to deepen conceptual understanding of fraction division while reviewing Lesson Two. The following prompts will be used.

- Given an eight inch length of licorice, how many pieces of two inches long can be made?
- Given an eight inch length of licorice, how many $\frac{1}{2}$ " pieces can be made?
- Given an eight inch length of licorice, how many $\frac{1}{4}$ " pieces can be made?

Students will have the materials in front of them to physically solve each problem; however, I am also prepared for some students to simply consume the licorice and solve the problems with pencil and paper. Ideally, this activity will reinforce the concept that dividing by a number is the same as multiplying by its multiplicative inverse. Also, it should serve to remind students the quotient of a

division problem can indeed be larger than both the dividend and the divisor. I also like this activity because it helps students visualize a division problem involving fractions.

Anticipatory Set 2

Next, students will have an opportunity to ask questions on the assignment from the previous class. Problems will be worked out, if requested. When all students are satisfied, the assignment will be collected.

Lesson Three Objectives

- I can add fractions.
- I can subtract fractions.

Input & Modeling & Guided Practice

The last two important things to know about fractions from the “TOP TEN” list appear in Lesson Three. #9 states that when adding and subtracting fractions, size matters (Figure 14). I hope to focus student attention onto denominators (denominations) throughout this lesson.

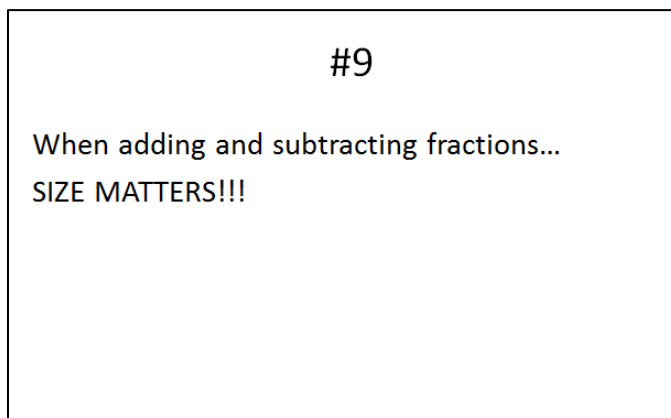

Figure 14

Before formally teaching how to add and subtract fractions, students are asked to pair up and take another look at the town they studied in the anticipatory set during Lesson One (Appendix D). This time, students are given four clues (Figure 15) related to people buying and selling land within the town.

Using the clues, students are asked to redraw the map and determine what fraction of the town each owner owns.

The City Council purchases land from Hans, Al, and Greg to expand the park.			
Ed buys land from one person and ends up with one-fourth of the town.			
Dan buys Cy's land.			
Fred neither buys nor sells land.			
So...what fraction of the town does each person own now?			
CITY_____	FRED_____	ED_____	DAN_____

Figure 15

Solving this problem requires students to (knowingly or unknowingly) work through the following problems: $\frac{3}{20} + \frac{1}{20} + \frac{3}{20} + \frac{1}{10}$; $\frac{1}{4} - \frac{3}{20}$; and $\frac{1}{5} + \frac{1}{20}$. It also becomes a point of reference for the rest of Lesson Three. I will be able to refer to these denominations and equivalent fractions as needed throughout the lesson.

At this point in the lesson, students are finally ready to formally see how to combine fractions. It will be important to stress to students that nothing they are about to see is new to them! They are already comfortable with creating equivalent fractions and they are already comfortable with adding and subtracting quantities of the same denomination. The key, at this point, will be demonstrating to students how useful their acquired skills truly are! The Lesson Three learning targets will be referred to (again) and the following problems will be modeled:

- $\frac{15}{16} - \frac{7}{8}$
- $\frac{3}{8} + \frac{3}{7} + \frac{7}{12}$
- $13\frac{1}{4} + 5\frac{5}{8}$
- $11\frac{9}{16} - 5\frac{3}{4}$

Special emphasis will be placed on the third example problem ($13\frac{1}{4} + 5\frac{5}{8}$). Students may be tempted to rename each number as an improper fraction because this is helpful when multiplying and dividing.

Care must be taken to ensure students do not think this is required for addition and subtraction problems. In fact, it often complicates the problem!

The fourth example problem above ($11\frac{9}{16} - 5\frac{3}{4}$) leads into the final important thing to know about fractions. We have reached the end of our top ten list (Figure 16)! There are many ways to rename a mixed number.

#10

There are many ways to rename a mixed number. For example:

$$4\frac{3}{7} = \frac{31}{7} \quad 4\frac{3}{7} = 1\frac{24}{7} \quad 4\frac{3}{7} = 2\frac{17}{7} \quad 4\frac{3}{7} = 3\frac{10}{7}$$

It's helpful to have options!

Figure 16

It is necessary to stop and address this before solving the fourth example problem. If time and student attention permit, the problem should be solved in at least two of the different ways as outlined below.

- $11\frac{9}{16} - 5\frac{3}{4} = 10\frac{25}{16} - 5\frac{12}{16} = 5\frac{13}{16}$
- $11\frac{9}{16} - 5\frac{3}{4} = 9\frac{41}{16} - 5\frac{12}{16} = 4\frac{29}{16} = 5\frac{13}{16}$
- $11\frac{9}{16} - 5\frac{3}{4} = 8\frac{57}{16} - 5\frac{12}{16} = 3\frac{45}{16} = 5\frac{13}{16}$
- $11\frac{9}{16} - 5\frac{3}{4} = 7\frac{73}{16} - 5\frac{12}{16} = 2\frac{61}{16} = 5\frac{13}{16}$
- $11\frac{9}{16} - 5\frac{3}{4} = 6\frac{89}{16} - 5\frac{12}{16} = 1\frac{77}{16} = 5\frac{13}{16}$
- $11\frac{9}{16} - 5\frac{3}{4} = 5\frac{105}{16} - 5\frac{12}{16} = \frac{93}{16} = 5\frac{13}{16}$

Students will probably need to be reminded that it is important to have denominators of the same size before deciding to rename any mixed numbers.

The final guided practice activity is a team challenge taken from the book Math for Welders (Marion, 2006, p. 64). Groups of four students will tackle this problem (Appendix I) without calculators.

Closure

The last bit of practice students will be expected to complete before leaving class is a five question exit slip (Appendix J). Students will work in groups of four to complete this particular exit slip. Four of the questions are taken from the text Math for Welders (Marion, 2006, p. 55, p.63) and one is taken from the text Practical Problems in Mathematics: For Welders (Chasan, 2009, p. 38). Each group should have five correct answers before leaving the classroom. This will be a good opportunity to clear up any remaining confusion and/or misconceptions before students are expected to practice the Lesson Three objectives independently.

Independent Practice

The independent practice for Lesson Three is a worksheet of 12 problems taken from Practical Problems in Mathematics: For Welders (Chasan, 2009, p. 31-32, p. 36-37). Seven problems will require students to practice adding fractions while the other five problems will require students to subtract. Each problem includes a detailed illustration of the metal(s) pieces involved (Appendix K).

Lesson Four

Anticipatory Set 1

As students enter the room, they will each pick up a slip of paper instructing them to prepare a short review presentation clearly explaining the solution to one addition or subtraction problem in their textbook, Applied College Mathematics: for Math 373 (Ewen & Nelson, 2011). When everyone is prepared, the presentations can begin. Each original problem from the text will be projected onto the

screen in front of the room (Appendix L), saving presenters from writing the original problem (especially helpful for lengthy word problems or problems with detailed diagrams). There are three different types of problems students will be asked to present; this will create a more well-rounded review for all. Six problems are straightforward addition or subtraction problems; they are simply numeric expressions which need to be simplified. Three presentations will feature word problems involving welding scenarios. The remaining five problems will be related to perimeter. Feedback will be given to each student immediately following his presentation. Feedback will be solicited from the class before I add my own two cents regarding each solution presented. It is my hope that students in the audience will catch errors or omissions before I have to address such mistakes.

Anticipatory Set 2

Next, students will have an opportunity to ask questions on the assignment from the previous class. Problems will be worked out, if requested. When all students are satisfied, the assignment will be collected.

Lesson Four Objectives

Lesson Four is devoted to reviewing all of the learning targets for the entire unit. These learning targets (Appendix E) will be communicated to students again during this class period.

Guided Practice

At this point, students will be divided up into three different teams to play The Bomb Game. The Bomb Game is a very unique review game; most students thoroughly enjoy the game while simultaneously benefiting from the review. Preparation for this particular game is relatively easy. First, I will create a set of 26 index cards. Each card will be labeled on the front with a letter (A through Z). On the back of each card will be either a point value (10, 20, 30, 40, or 50) or a picture of a bomb (Figure 17). In addition, I will need a list of 26 review questions to correspond to each letter of the alphabet (Appendix M).

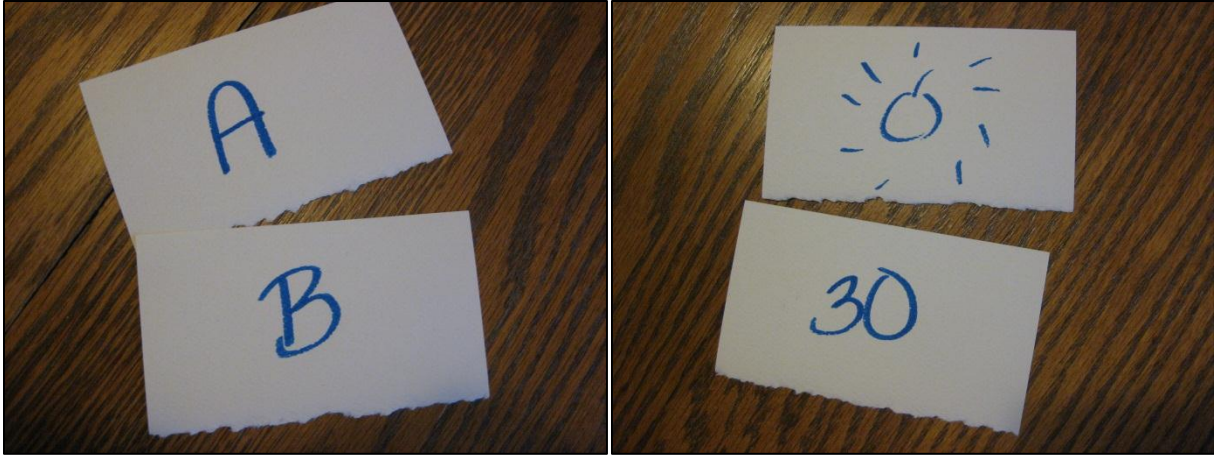

Figure 17

One player will represent his team each time it is his team's turn. The player will come up to the front of the room and choose a letter (without picking up the corresponding card). I will then read the question matching the letter and the student will give his answer. If the student does not get the question correct, nothing happens. He simply sits down and the play moves to the next team. However, if the student does get the question correct, he and his team have a choice to make. They can choose to pick up the card corresponding to the question or pass the card to either of the other two teams. It is important to note their choice must be made prior to picking up the card and looking at the back. If the card shows a point value, the team (or the team they have chosen to pass the card to) earns the amount of points shown. If the card shows a bomb, the team (or the team they have chosen to pass the card to) loses all of their points.

I like to use this game to review for several reasons. First, unlike other classroom games, student embarrassment is fairly minimal. The main reason for this is that getting a question wrong is not the worst thing that can happen to a team. When a student misses a question, nothing happens. In fact, losing points (getting a card with a bomb) can only happen when a student gets a question right. Second, students stay engaged throughout the entire game. This is due to the fact that no lead is large enough to clinch a win for a given team. Any team can lose all its points at any time, even down to the last remaining card on the table. Finally, this game strikes the delicate balance between luck,

knowledge, and strategy. Teams need all three in order to win. This is nice for teachers because teams can be selected at random. There is generally no need to carefully sort teams into evenly matched ability groups. The nature of the game forces all teams onto an even playing field.

Closure & Independent Practice

The independent practice following Lesson Four is also the take-home portion of the test (Figure 18). Part of the take-home test is a textbook assignment (Ewen & Nelson, 2011). The other part of the take-home test is an exercise similar to the map activities completed by students earlier in the unit.

TAKE-HOME PORTION OF THE TEST

1. Before you leave today, determine what fraction of a section each person owns. Get your answers checked by [Grettel](#).
2. Use the six clues to determine what transactions took place. Draw a new map of the two sections, outlining the land belonging to the owners who are left. Tell what fraction each owner owns now.
3. BOTTOM OF PAGE 56: 1-8, 11

Figure 18

This particular map activity is taken from the textbook [Bits and Pieces II: Using Rational Numbers: Teacher's Guide](#) (Lappan et al., 2004). Students are first given a picture of a town divided into two sections (Figure 19). Students are instructed to determine what fraction of a section (not of the whole town) each person owns prior to leaving class. This activity is important for two reasons. First, it will allow each student one final check-in with me prior to the test. Second, it will ensure each student has started this complex problem with correction information. If students walk out of class without a clear understanding of the size of each person's land, their score on the take-home portion of the exam will suffer greatly.

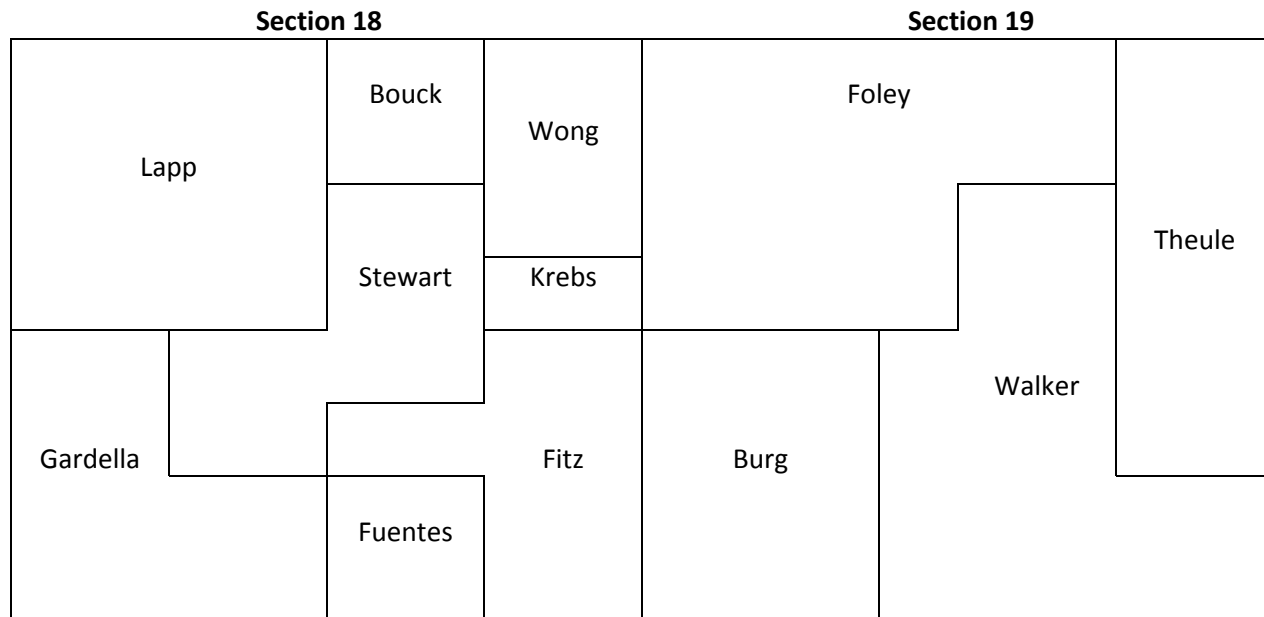

Figure 19

Before the next class meeting, students must examine a set of clues related to land transactions and must draw a new map of the town. Finally, they will have to determine again what fraction of a section each resident owns. The six clues are listed below.

- Clue 1** When all the sales are completed, four people – Theule, Fuentes, Wong, and Gardella – own all of the land in the two sections.
- Clue 2** Theule bought from one person and now owns land equivalent to $\frac{1}{2}$ of one section.
- Clue 3** Fuentes bought from three people and now owns the equivalent of $\frac{13}{32}$ of one section.
- Clue 4** Gardella now owns the equivalent of $\frac{1}{2}$ of a section.
- Clue 5** Wong now owns all of the rest of the land in the two sections.
- Clue 6** Each of the four owners can walk around all of their land without having to cross onto another person's land (Lappan et al., 2004, p. 45).

Lesson Five

Anticipatory Set

Students will have an opportunity to ask questions on the textbook assignment (part of the take-home test) from the previous class. Problems will be worked out, if requested. When all students are satisfied, the textbook assignment as well as the map assessment will be collected.

Independent Practice

Students will take the final assessment of the unit, the exam (Appendix N).

Many factors will ultimately contribute to the level of effectiveness of the Fractions for Welders curriculum. I expect student progress (as measured by growth from pre-tests to post-tests) to be enhanced by variables such as class participation, attentiveness, attendance, homework completion, and willingness to ask for help when needed. The actual implementation of the curriculum will be an influence as well. All teachers know there is a difference between detailed lesson plans on paper and what actually occurs within the classroom walls. It is difficult to predict, for example, the amount of time the team challenge from Lesson Three will take or how many students will struggle with renaming a fraction in order to calculate a subtraction problem. Regardless, the fundamental goal of the unit remains the same: increase each individual student's conceptual knowledge of basic fraction operations. A thorough analysis will detail the progress made during the course of the Fractions for Welders unit.

Chapter 4

Results

The purpose of this particular curriculum project was to analyze the effectiveness of the Fractions for Welders curriculum. The original foundation of this unit was developed for seventh graders. It has been modified and implemented at the technical college level with a group of welding students in their second semester at Wisconsin Indianhead Technical College (WITC). Special emphasis was placed on an alternative to the standard algorithm for dividing fractions. Twelve of the 14 students enrolled in the course were adult learners; the other two students were minors who were still in high school. Therefore, I only collected data and student artifacts for 12 participants (the adults).

Participants took a formal pre-test one week before the actual start of the unit, Lesson One. The quiz consisted of six short items involving basic operations with fractions (Appendix C). The pre-test contained one item dealing with each of the four basic operations: addition, subtraction, multiplication, and division. The other two test items were more conceptual in nature: correctly labeling marks on a tape measure and renaming wholes as a specific quantity of fourths. In addition to the formal pre-test, the anticipatory set from Lesson One served as another baseline test of student knowledge (Appendix D). This simple map activity was completed by students working in pairs and functioned as a pre-test for the take-home portion of the unit exam.

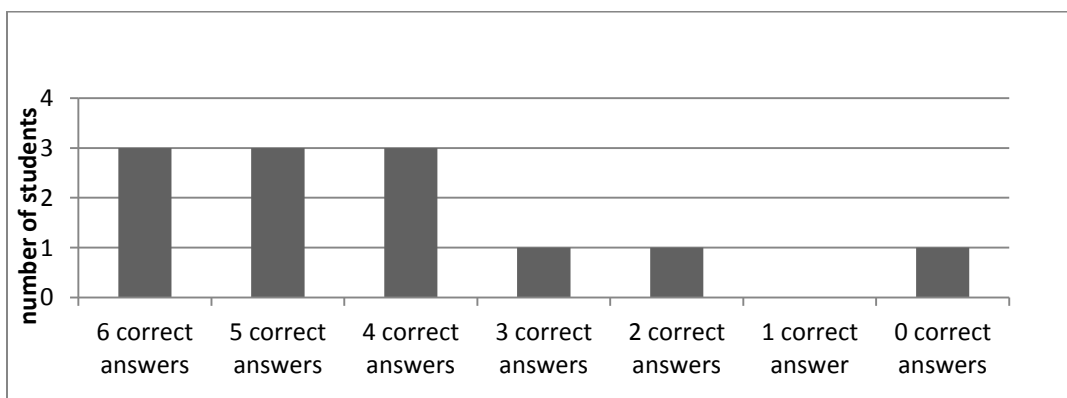

Figure 20

Three students made no errors on the pre-test while one student missed every single question. A breakdown of all the scores is shown in Figure 20. The mean score on the pre-test was 4.17 while the median was 4.5. Three participants missed item 1 (Figure 21). Instead of answering the question, one student simply wrote, “I never learned how to read a tape measure”. This same student added, “Fractions are the hardest for me” at the top of his pre-test. Another student incorrectly labeled $\frac{7}{16}$ of an inch as $\frac{3}{8}$ of an inch. The last student did not label $2\frac{1}{16}$ of an inch; in fact, he did not write down any answer.

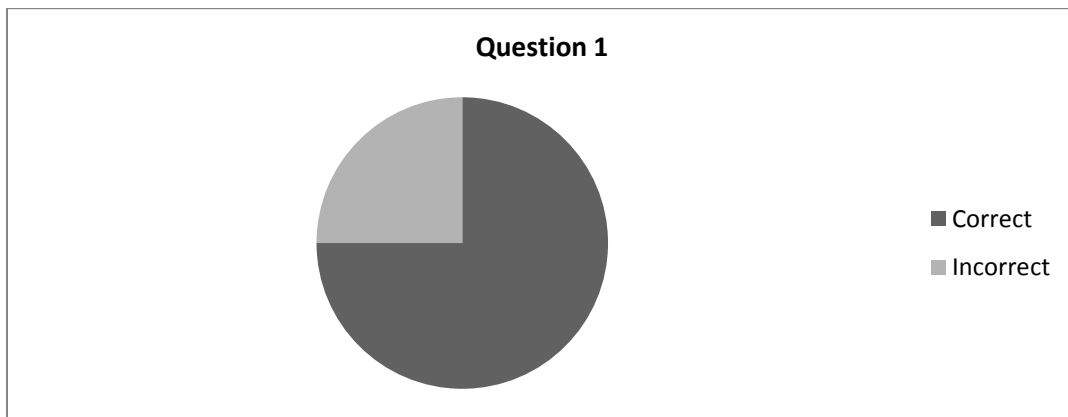

Figure 21

Just two students missed item 2 (Figure 22). One student (the one who missed every question) wrote, “I don’t know how to attack it”. The other student stated there were 34 fourths in 17 wholes.

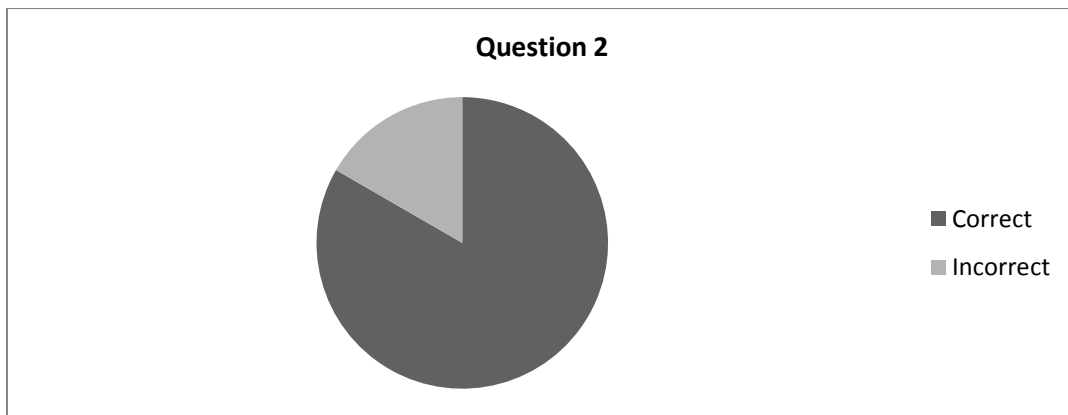

Figure 22

Three students missed item 3 (Figure 23). Two students generated incorrect answers to the problem $13\frac{1}{4}$ lbs + $10\frac{1}{8}$ lbs + 4 lbs (they responded with $22\frac{3}{16}$ lbs and $37\frac{1}{6}$ lbs) without showing their method. One student responded with $13\frac{1}{4} + 10\frac{1}{8} + 4 = 27\frac{2}{12}$. It appears this student made a rather common error. He added the whole numbers to get 27 and then added the numerators together ($1 + 1 = 2$) as well as the denominators ($4 + 8 = 12$).

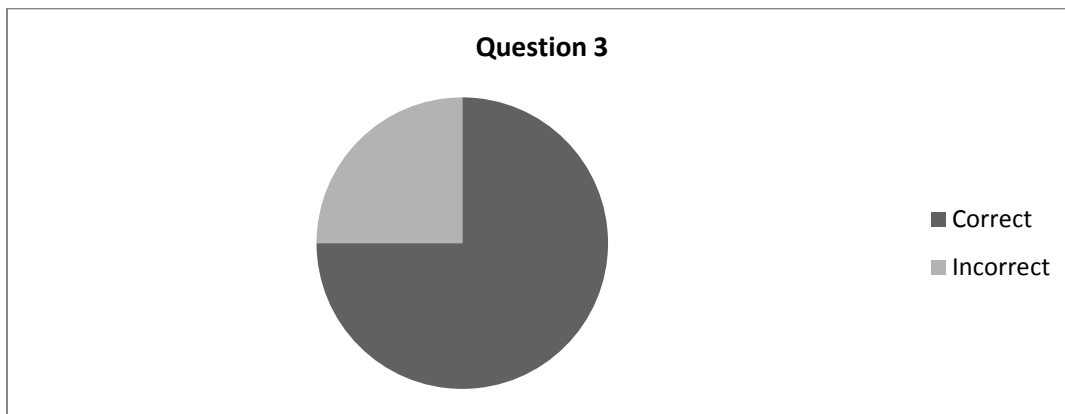

Figure 23

Three students missed question 4 (Figure 24). After the instructions “Determine the missing dimension”, one student wrote, “How?” Another student did not respond at all while a third student wrote $\frac{7}{8} - \frac{12}{8} = \frac{1}{8}$ and came up with an answer of $7\frac{1}{8}$ in (the correct answer was $8\frac{1}{8}$ in).

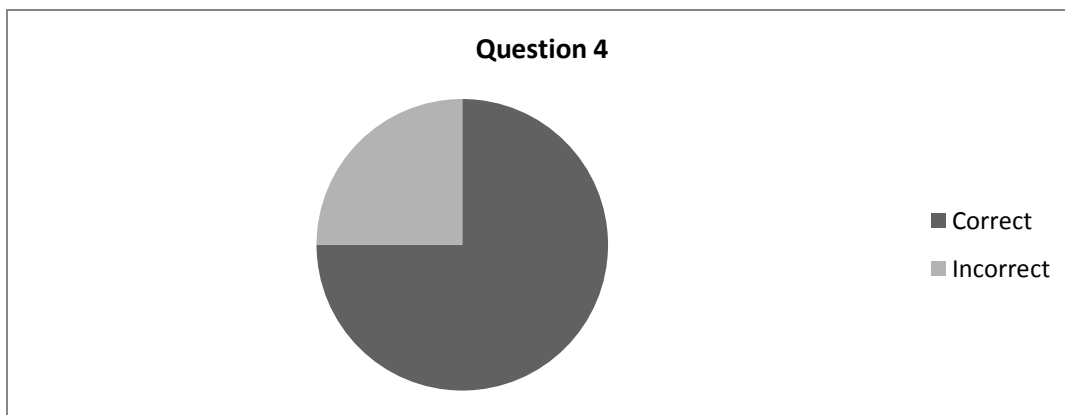

Figure 24

Two students missed item 5, the fraction multiplication problem (Figure 25). One student left it blank while the other incorrectly answered “ $8\frac{1}{2}$ long”. The correct answer was $32\frac{1}{2}$ in.

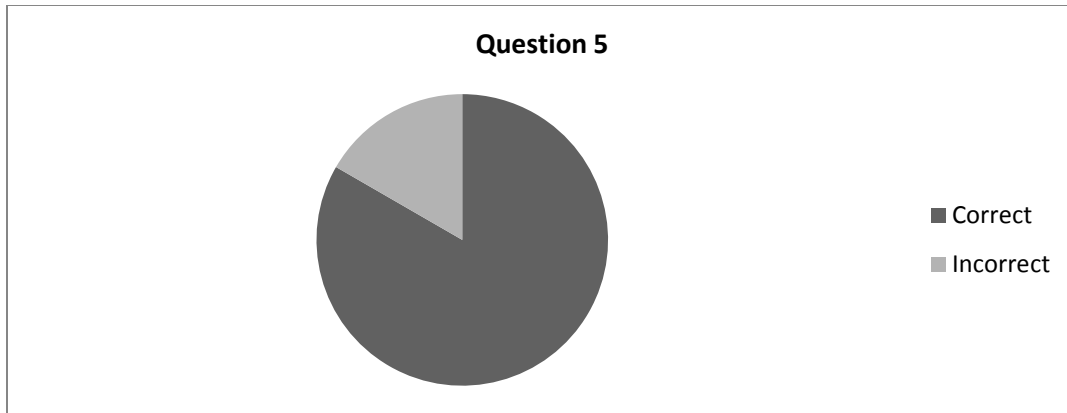

Figure 25

The most significant item from the pre-test was item 6. Nine of the participants missed the question which required knowledge of fraction division (Figure 26). This result is not surprising, especially when considered alongside the educational research of the past few decades.

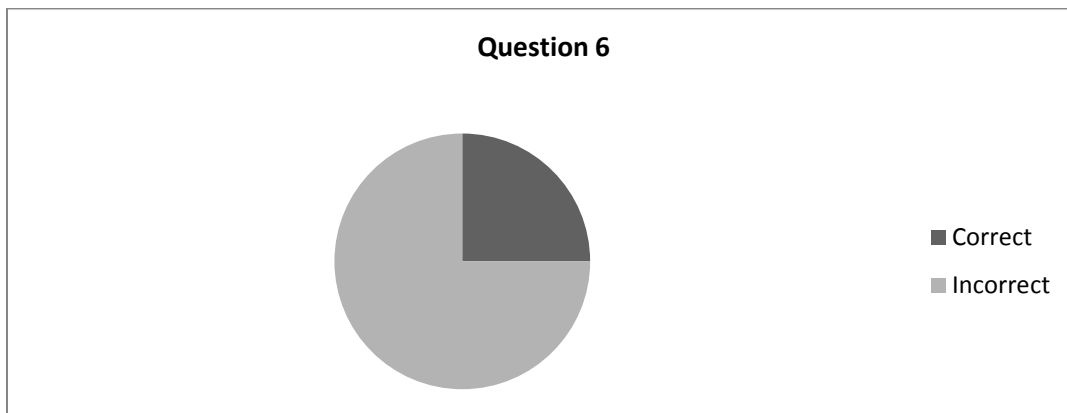

Figure 26

Three students correctly responded with $19\frac{1}{16}$ ". Two students left this question blank. Two others provided incorrect answers (11 and 12.7") with no supporting work. One student began to divide 38 by 6 using long division, but did not get very far. Four of the remaining students worked with decimal numbers instead of fractions. Of these four, two students generated correct answers; both used a similar method: $38\frac{1}{8}$ or $38.125 \div 6 = 6.354 \times 3 = 19.0625$. Another student working with decimals used 38.1875 instead of 38.125; he came up with an incorrect answer of 19.0935. The final student who used decimal numbers to solve the problem correctly computed a sixth of $38\frac{1}{8}$ but, when multiplying by 3,

rounded incorrectly and arrived at an answer of 19.062. Only one student who computed with fractions reached the correct answer, and he used a calculator to do so. The final two incorrect responses are shown below:

- $\frac{1}{8} \times \frac{3}{1} = 12 \frac{17}{24}$ in.

- $38 \frac{1}{8} \div 6 = 6 \frac{1}{8} = 2 \frac{3}{8}$

The warm-up activity students completed before officially beginning their study of fractions also served as an effective pre-test of students' conceptual understanding of fractions (Appendix D). It also functioned as a nice introduction to the role of the denominator as a denomination and to the role of the numerator as a counter. In general, pairs had no trouble determining the fraction of the land Dan owns ($\frac{1}{5}$) nor the fraction of the town Cy, Fred, and Hans own ($\frac{1}{20}$). With the exception of one pair, all groups needed assistance with at least one of the other landowners. Simplification was one issue; many students needed help figuring out that $\frac{2}{20} = \frac{1}{10}$. Lots of students were stumped by the landowners who own $\frac{3}{20}$ of the town. The problem appeared to be that they were only considering fractions with a numerator of 1 (commonly referred to as unit fractions). In one case, I needed to draw lines on the students' map so they could visually see the twentieths within Ed's land.

All six items from the formal pre-test appeared on the unit exam (Appendix N). As a group, student performance improved; they went from a class mean of 4.17 to a class mean of 5.25 while the median score increased from 4.5 to 5. Five students provided correct answers for all six items (up from three on the pre-test). It is also significant to note the worst score on the pre-test was 0 while the worst score on the post-test was 4. A summary of all the scores is displayed in Figure 27 while Figure 28 clearly shows growth, question by question, from pre-test to post-test.

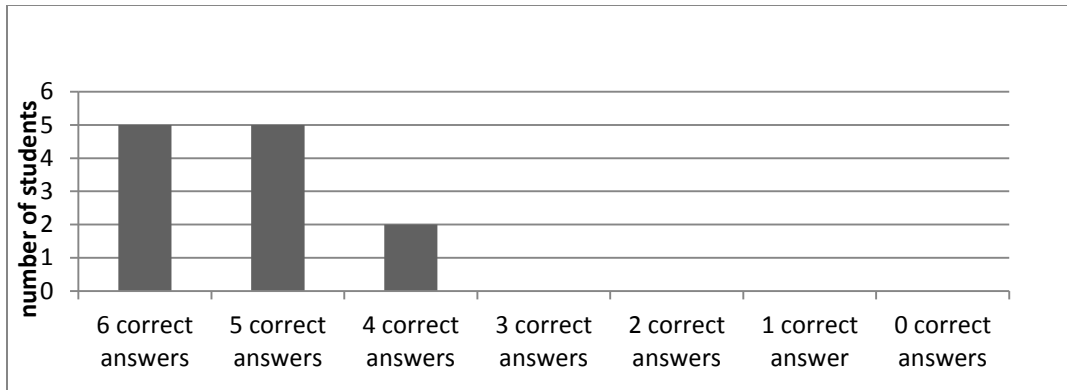

Figure 27

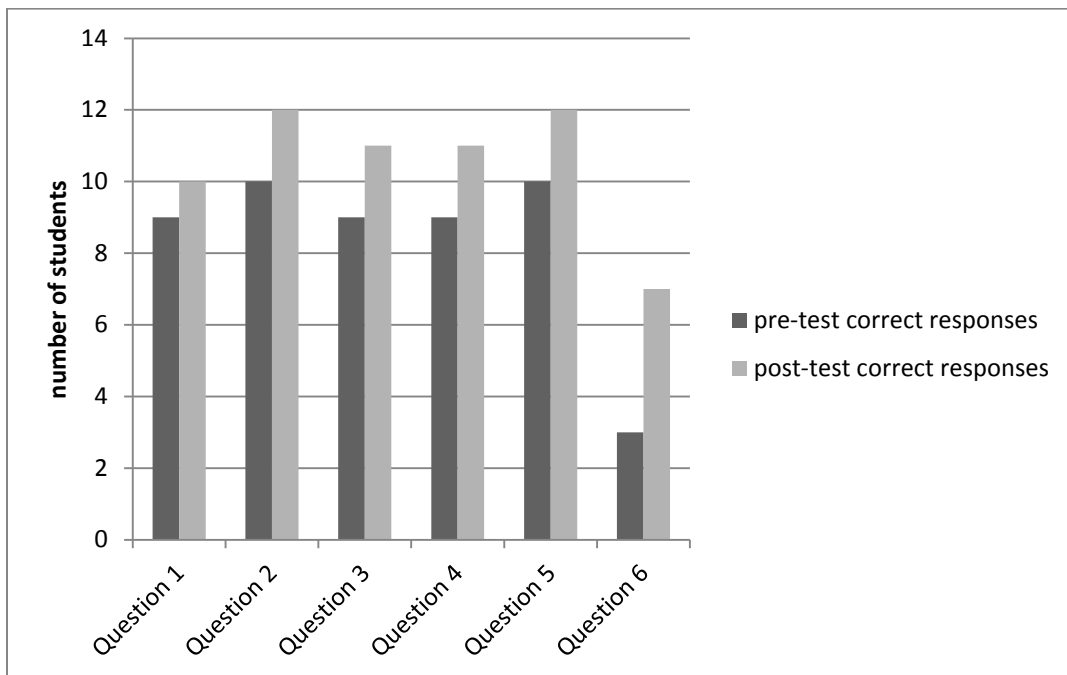

Figure 28

Two students missed the first question. One of these participants missed the entire question. When asked about it later, he said he had rushed through the test and forgotten to complete the problem. The other student missed one piece of the six-part question. He left one measurement blank. Incidentally, he provided a correct answer for that particular measurement on the pre-test. Every student answered item 2 correctly. Just one person missed question 3. After correctly converting $13\frac{1}{4}$ to $13\frac{2}{8}$ and correctly adding the fractional parts of the mixed numbers, he added the whole numbers wrong and came up with an incorrect final answer of $28\frac{3}{8}$ lbs instead of $27\frac{3}{8}$ lbs. Only one participant offered a

flawed response for question 4. After correctly converting $\frac{3}{4}$ to $\frac{6}{8}$ he incorrectly calculated the following subtraction problem: $8\frac{7}{8} - \frac{6}{8} = 8\frac{1}{2}$. I'm not sure if he accidentally wrote a 2 instead of an 8 in the denominator or if he subtracted 6 from 8 to get 2. All of the students correctly answered question 5. Seven students accurately responded to item 6. Due to the curriculum focus on fraction division, I've included all 12 responses to this question (Figure 29).

CORRECT RESPONSES	INCORRECT RESPONSES
$6\frac{17}{48}$ each $19\frac{1}{16}$ "	$38\frac{1}{8} \div 6 = 6\frac{5}{8}$ $\frac{354}{1} \times \frac{32}{32} =$ $37\frac{9}{8}$
$38\frac{1}{8} \div \frac{6}{1} = \frac{305}{8} \times \frac{1}{6} = \frac{305}{48}$ This student wrote out the above work, then erased it to write: $6\frac{17}{48} \times 3 = 19\frac{1}{16}$ "	$\frac{1}{8} = .125$ $38.125 \div 6 = 6.35" = 19.05"$ This student rounded to the hundredths (6.35) instead of thousandths (6.354); ultimately, this caused him some accuracy.
$\frac{305}{8} \cdot \frac{1}{6} = \frac{305}{48} = 6\frac{17}{48}$ $6 \times 3 = 18$ $\frac{17}{48} \times \frac{3}{1} = \frac{51}{48} = 1\frac{3}{48} = 1\frac{1}{16}$ $19\frac{1}{16}$ "	$\frac{304}{8} \div \frac{6}{1} = \frac{304}{8} \cdot \frac{1}{6} = \frac{304}{48}$ $6\frac{16}{48} \cdot \frac{1}{3} = 6\frac{1}{3}$ $\frac{19}{3} \times \frac{3}{1} = \frac{19}{1} = 19"$
$\frac{305}{8} \times \frac{1}{6} = \frac{305}{48} = 6\frac{17}{48} \times 3$ $\frac{305}{48} \times \frac{3}{1} = \frac{915}{48} = 19\frac{3}{48} = 19\frac{1}{16}$ in	$38\frac{1}{8} \div 6 = 6\frac{17}{48}$ $6 \times 3 = 18$ in This student forgot to multiply $\frac{17}{48}$ by 3.
$19\frac{1}{16}$ "	$12\frac{17}{24}$ "
$6\frac{17}{48}$ $19\frac{1}{16}$ "	
$19\frac{1}{16}$ "	

Figure 29

The final post-test was part of the take-home portion of the end-of-unit exam. The pre-test for this portion of the unit exam was the anticipatory set from Lesson One (Appendix D), which students completed in groups of two. For the map activity post-test, students were given a picture of a town divided into two sections (Figure 30).

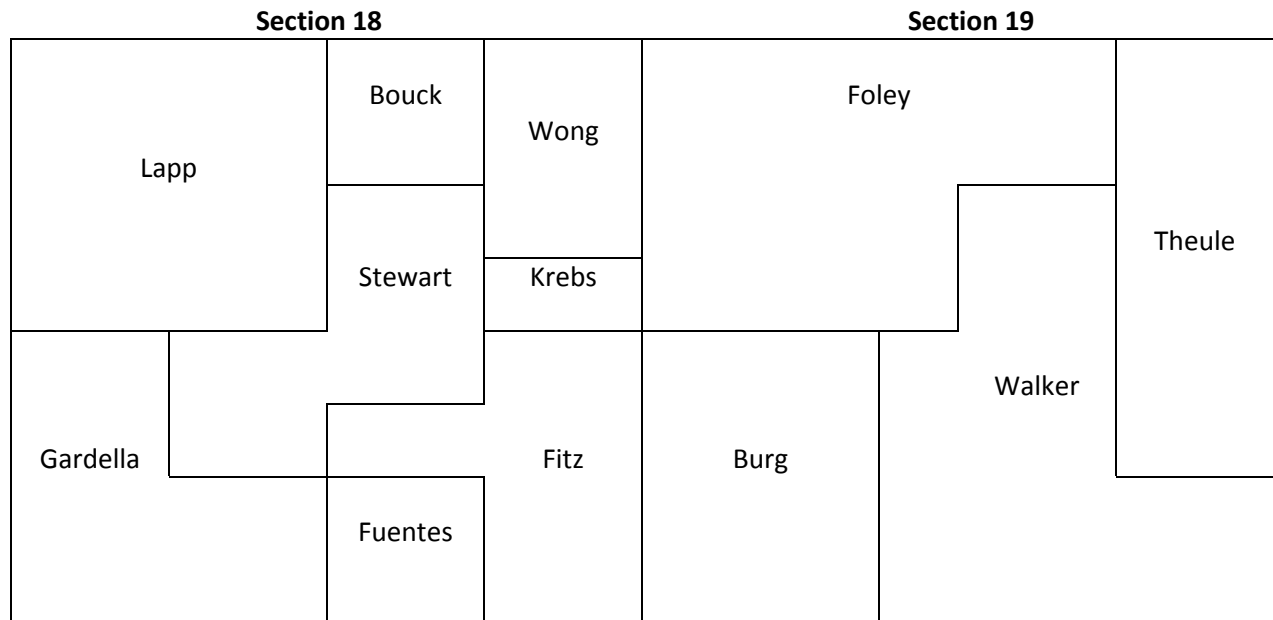

Figure 30

Students were instructed to determine what fraction of a section (not of the whole town) each person owns prior to leaving class after Lesson Four. Then, they needed to examine a set of clues related to land transactions and draw a new map of the town. Finally, they had to determine again what fraction of a section each resident owns. The six clues are listed below.

Clue 1 When all the sales are completed, four people – Theule, Feuentes,

Wong, and Gardella – own all of the land in the two sections.

Clue 2 Theule bought from one person and now owns land equivalent to

$\frac{1}{2}$ of one section.

Clue 3 Fuentes bought from three people and now owns the equivalent

of $\frac{13}{32}$ of one section.

Clue 4 Gardella now owns the equivalent of $\frac{1}{2}$ of a section.

Clue 5 Wong now owns all of the rest of the land in the two sections.

Clue 6 Each of the four owners can walk around all of their land without having to cross onto another person's land (Lappan et al., 2004, p. 45).

With the exception of one student (who didn't do the first part of the activity in class so I could double-check his work), all of the participants successfully determined what fraction of a section each person originally owned. The student who did this piece outside of class had one landowner's fraction wrong. He said Stewart owned $\frac{1}{16}$ of a section when Stewart actually owned $\frac{5}{32}$ of a section.

Three students followed the directions to redraw the map using a copy of the original map I had provided. Of these three, two correctly generated an updated map and included four new (and accurate) fractions representing land ownership (Figures 31 and 32). The third drew an inaccurate map and did not attempt to describe the fraction of a section the four remaining owners maintained (Figure 33).

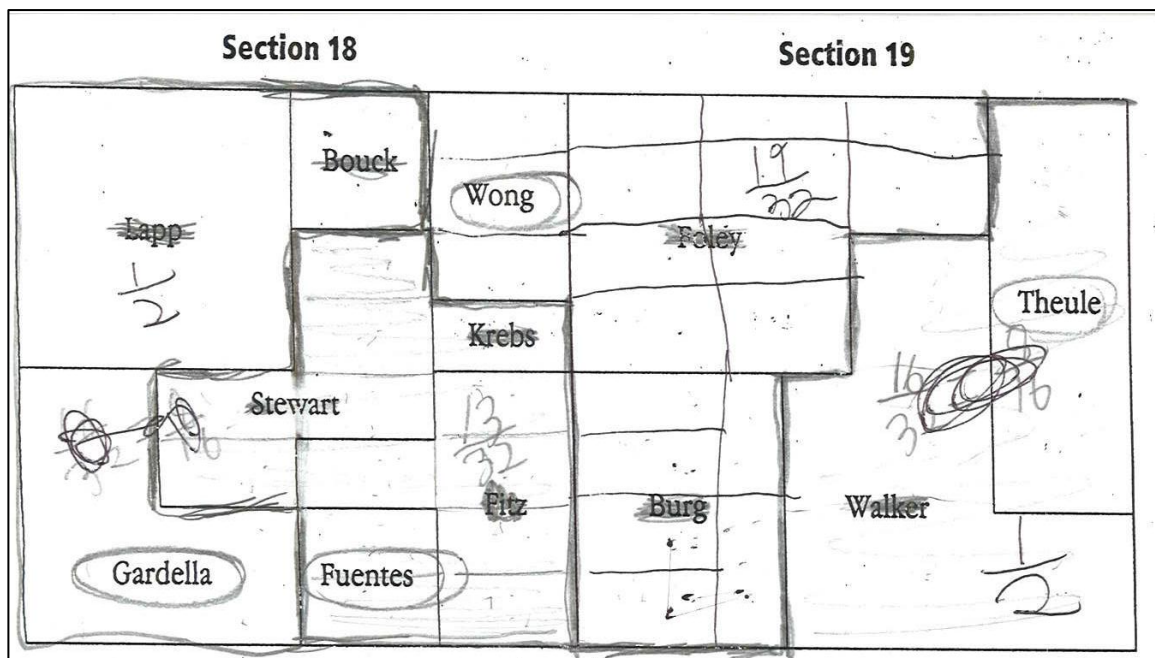

Figure 31

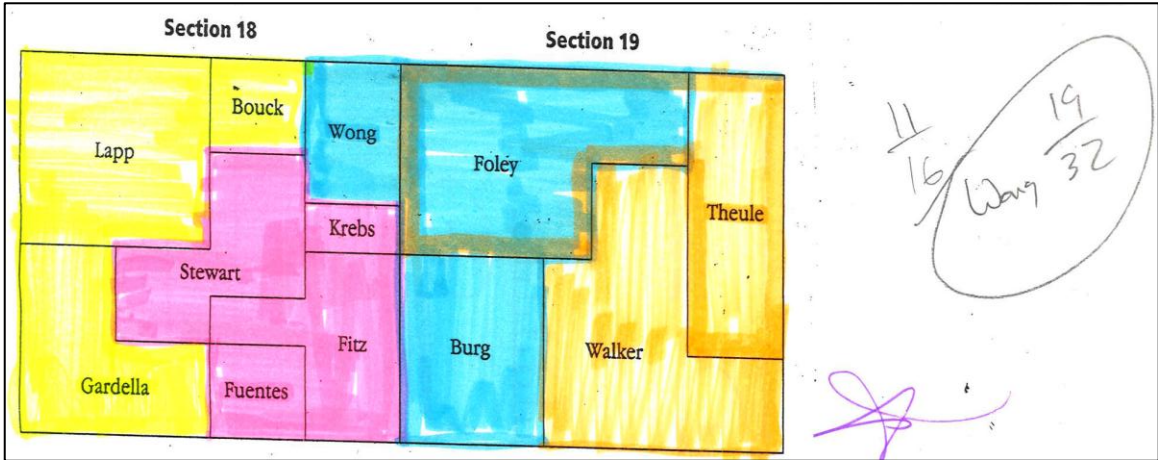

Figure 32

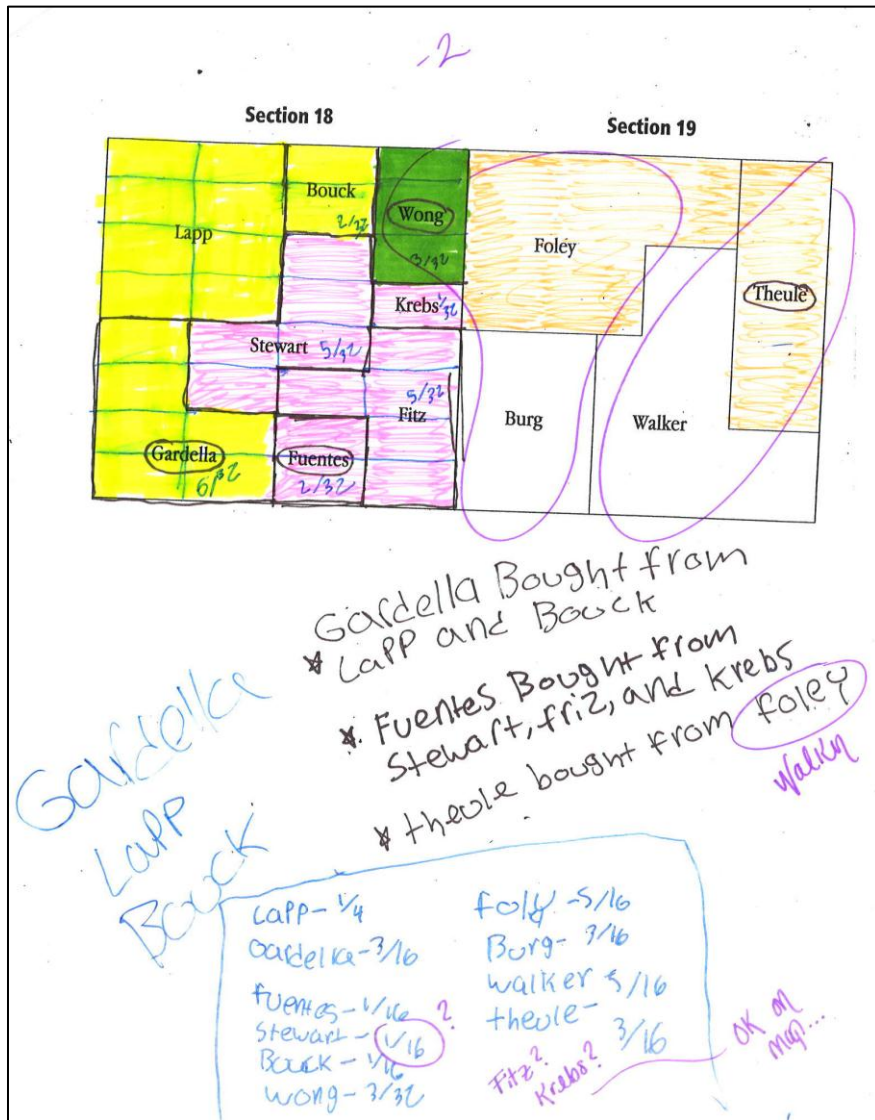

Figure 33

The other nine attempted to freehand a sketch of the new boundaries, with disastrous results. The drawings were extremely rough, although correct, outlines. The rough drawings also created trouble for students figuring out the final fractions. Keep in mind, three of the resultant fractions representing land ownership had been given to students within the clues! Two students labeled all four parcels of land incorrectly. Three students labeled three of the four parcels of land incorrectly. One person was able to correctly determine two of the final four fractions (Figure 34) and one student correctly identified three of them (Figure 35).

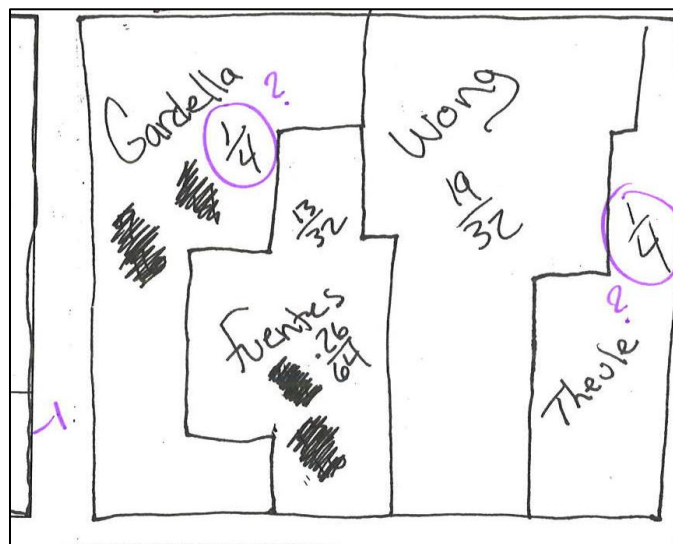

Figure 34

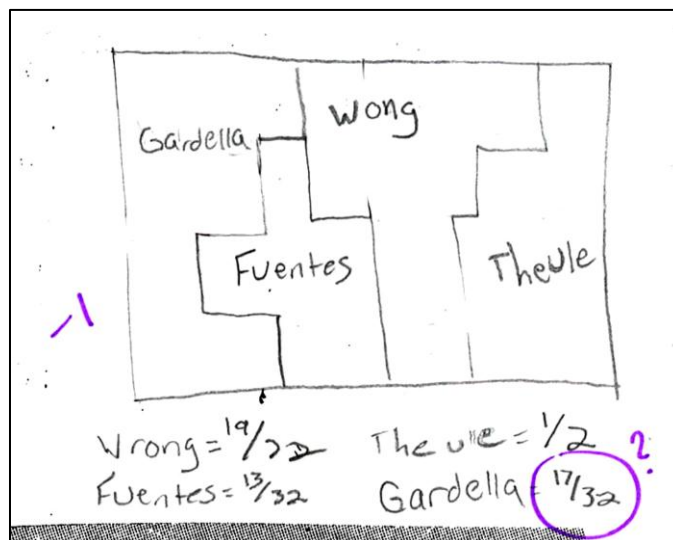

Figure 35

Just two students who generated inferior drawings were still able to identify all four of the final fractions representing land ownership (Figure 36). Overall, only four out of 12 participants were able to proficiently complete this portion of the post-test.



Figure 36

Absenteeism during the unit may have had an effect on student achievement on the unit test. Seven of the twelve participants missed a day of class during the course of the Fractions for Welders unit. Unfortunately, with 80-minute class periods, missing a class means missing a great deal of material. It is worth noting the mean unit test grade for students who missed a class was 85.2% while the mean unit test grade for students with perfect attendance was 87.3%.

Positive results did occur throughout the course of the Fractions for Welders curriculum. Improvement was observed on all six questions from the pre-test. In fact, the number of students who answered the division question correctly on the post-test more than doubled (Figure 28). The mean score on the pre-test improved from 4.17 to 5.25 while the median score increased from 4.5 to 5. In addition, the range of scores on the pre-test was 0 to 6 while the range of scores on the same six items at the end of the unit was 4 to 6. An extremely positive shift occurred. Less progress was visible with relation to the map post-test. Only four students were able to accurately complete this portion of the

unit test. Closer examination of the implementation of the unit is needed to determine possible causes behind the growth (and lack thereof) that has been seen.

Chapter 5

Reflection

Encouraging progress and student growth was accomplished via the Fractions for Welders curriculum. There were also some components of the lessons I would have like to have handled differently. I would like to take some time to discuss the implementation of each lesson in detail: activities that went smoothly, activities that should be discarded, and any changes I plan to make in preparation for the next time I teach Math 373.

Two changes come to mind immediately related to pre-tests. In order to fully grasp the conceptual knowledge (or lack thereof) students are bringing with them into class, I need to do a better job pre-testing them.

The first modification I will make is related to the Lesson Two exit slip (Figure 37). Lesson Two is simply too late into the unit for that exit slip to effectively guide teaching. In the future I will add several questions like those on the exit slip directly to the pre-test itself because understanding students' attitudes, fears, and misconceptions is every bit as important as diagnosing their performance on a handful of problems.

PLACE AN "X" NEXT TO ANY STATEMENT THAT IS TRUE.

- _____ I prefer working with decimal numbers over fractions.
- _____ I didn't realize I could "divide straight across" until today.
- _____ I remember being told (by a former teacher or other adult) not to "divide straight across".
- _____ I prefer working with fractions over decimal numbers.
- _____ I make more mistakes working with fractions than working with whole numbers.
- _____ I understand how to use the fraction tools available on my calculator.
- _____ I am better at adding/subtracting fractions than multiplying/dividing fractions.
- _____ I am better at multiplying/dividing fractions than adding/subtracting fractions.

Figure 37

That being said, the checklist in Figure 37 needs some revisions. In the future, I think I will replace the two statements about dividing straight across with a short answer question similar to the problem posed to students in the Tirosh (2000) study. She offered students a chance to think about generalizing the rules of fraction multiplication to extend to the other three operations: addition, subtraction, and division (Tirosh, 2000). I also think the list of statements should include a sentence or two related to mixed numbers and improper fractions. In the Fractions for Welders curriculum these concepts were covered in Lesson One and therefore were excluded from the Lesson Two exit slip. On a pre-test, however, a few statements like the ones below would be very relevant.

- I am comfortable with the terms "mixed number" and "improper fraction". In fact, I can provide an example of each: _____.
- The numerator (top) of a fraction should always be less than the denominator (bottom).
- The fraction $\frac{92}{9}$ is written in simplest form.

The second modification I would make to the pre-test involves acquiring more information from the students themselves. One way to do this would be to ban calculators, forcing students to show all of

their work. This is slightly problematic due to the fact that several students warrant special accommodations; a common modification is to be allowed the use of a calculator *at all times*. Instead, I could either implore students to show every step needed to arrive at their answers or I could personally interview them after taking the pre-test. This would allow me to hear, in their own words, their confidence (or their struggles) with fractions.

Overall, I was pleased with the implementation of Lesson One. The Top Ten List seems to be a decent way of organizing the material; students appear to appreciate having a sense of the timeline we will be on throughout the unit. Lesson One covers a great deal of material and three learning targets:

- I can find equivalent fractions by multiplying a given fraction by a "version of 1".
- I can simplify a given fraction by dividing it by an appropriate "version of 1".
- I can rewrite a mixed number as an improper fraction (and vice versa).

Students really seemed to enjoy the video clip related to mixed numbers and improper fractions. I admit, I was concerned adult learners would find it too elementary. Instead, participants seemed to enjoy the lighthearted nature of the clip.

One drawback to the way information was presented in this lesson is that dealing with "versions of one" seemed to be a nuisance for the students who were already comfortable with simplifying fractions and creating equivalent fractions. Students kept saying, "multiply the fraction by three" instead of, "multiply the fraction by three-thirds". At times, teacher guidance in this matter was viewed as unnecessary nagging. I really tried to differentiate between "dividing by two" and "dividing by two over two". Sometimes this was a hard sell to students who claimed, "you know what I mean". In fact, several times throughout this unit I felt I was a living example of one of Skemp's mis-matches; some students resisted my nudging into deeper conceptual understanding, content with their instrumental understanding of the topic at hand.

One change I will definitely make to Lesson Two in the future is to modify the Fly-Swatter game. During the Fractions for Welders project, we played a few rounds where I name an improper fraction and students had to hit the corresponding mixed number. Next time I will follow a round like that with a round of mixed numbers to improper fractions.

Not surprisingly, the brownie activity was as popular with adult learners as it used to be when I taught seventh grade. I had one student start to eat his brownie before we accomplished any math with it; this, too, is similar to teaching seventh grade. In the future I will make it clear the brownies are for a specific purpose and are not just a random snack. I also wish I had set aside more time for the mental math discussion following the brownie activity. Students were interested and seemed motivated to practice their newfound skill and I worry I may have rushed through the lesson a bit in order to get to #7 on the Top Ten list: When dividing with fractions, you've got to have a Plan B.

Students really stayed focused for the entire length of the presentation about dividing fractions. It is tempting to use the online stopwatch daily but I am quite sure the novelty of this tool is the majority of its effectiveness. True to form, a student from the back row stopped me to question the method involving dividing straight across. He offered, "what if you get a decimal?" I asked him to elaborate for the benefit of the rest of the class. Once he did, we were off and running. It was a truly seamless transition from one method to the other. By the end of the discussion, another student actually said, "why didn't they teach us that before?"

The BrainPOP video clip following #8 on the Top Ten list (when multiplying and dividing fractions, remember to change whole numbers and mixed numbers into improper fractions) is entertaining and a nice change of pace from the rest of the lesson. I think the characters actually resonate with the students. That being said, I do not think the quiz following this particular clip is very useful. I think it used up time that could have been better used during the station activity.

The station activity worked very well. Students were ready to move around the room at that point. Most students seemed to need help with station #3 so I spent most of the work time at that table. It was a good way to make sure I touched base with all of the students during the independent work time. Station #3 asked students to determine the distances between four evenly spaced holes on a piece of angle iron (Figure 12). The common error with this type of problem is to divide by the number of holes rather than by the number of spaces.

Lesson Three began with the licorice challenge. As such, it was not much of a challenge. I definitely think I need to offer problems where students will have to deal with remainders. It is much too easy when the divisor is a unit fraction. The next time I teach this unit I will hand out more licorice, set aside a bit more time, and get into problems like:

- Given an eight inch piece of licorice, how many $\frac{3}{4}$ " pieces can be cut? How much licorice is left?
- Given an eight inch piece of licorice, how many $2\frac{1}{2}$ " pieces can be cut? How much licorice is left?
- Given an eight inch piece of licorice, how many $1\frac{1}{4}$ " pieces can be cut? How much licorice is left?

We revisited the fictional town from Lesson One as our introduction to adding and subtracting fractions. I intended for this learning activity to be a nice bridge along the way from the opening activity of the unit to the take-home portion of the post-test. I wrote clues to push students into adding and subtracting as they determined exactly which transactions took place in this town. Looking back, however, I realize this was not a challenging enough quest to adequately prepare students for the post-test version of this problem. Did it sufficiently introduce the day's learning targets? Yes. Did it satisfactorily challenge students? No. I will make modifications to this activity the next time around. First, I will make sure the map of the town contains more landowners. Also, I will separate the town into two different sections just like the post-test. I think it was confusing to students when throughout the unit, they were asked, "what fraction of the town does each person own?" only to be asked on the post-

test, “what fraction of a section does each person own?” It makes sense to expose students to this different type of problem prior to the final test.

The team challenge from Lesson Three turned out to be my favorite activity from the entire unit. The level of difficulty was perfect for students at this particular point in the unit. Students worked well together, asked for help when needed, and successfully completed the challenging four-part problem without calculators.

The review presentations at the beginning of Lesson Four took far too long. In the future, I will definitely pair up students for talks like this. In my effort to create a sufficient review exercise, I included far too many questions. Half as many would have been more than adequate and students probably would have done a better job with the presentations. It was disappointing and I am not sure it helped students get ready for the unit test beyond the preparation they each got from planning their own presentation. Lesson Four wrapped up with the Bomb Game. Students love this game and I do find it to be a pretty effective way to highlight learning targets as well as specific problems ahead of a big exam.

The Fractions for Welders curriculum differs from traditional curriculums in several ways. The most obvious aspect to a casual observer is the order in which operations with fractions are taught. I found that when addition and subtraction are taught first, students tend to become so accustomed to finding common denominators that they immediately do so regardless of the operation at hand. This can turn simple problems like $\frac{8}{3} \times \frac{11}{14}$ into $\frac{112}{42} \times \frac{33}{42}$. From here, it is still *possible* to arrive at the correct answer, but most students do not. Common errors include computational mistakes due to the large numbers involved as well as forgetting to multiply the denominators together. I was thrilled to see participants in Fractions for Welders did not make this mistake, ever. It seemed to validate this major modification I had experimented with. Unfortunately, another issue surfaced. It turns out that when students learn how to multiply and divide fractions first, they still are prone to mistaken generalizations!

I had several students attack every problem involving mixed numbers by first converting all numbers into improper fractions. This is often the easiest route to take when dealing with fraction multiplication and fraction division problems; however, applying this step to addition and subtraction problems often replaces a straightforward problem with a complex challenge. For example, $11\frac{2}{5} + 24\frac{3}{10}$ becomes $\frac{57}{5} + \frac{243}{10}$. Again, students can still find the right answer but many would struggle to compute $\frac{57}{5} + \frac{243}{10}$ without error. In the future I may investigate the effects of introducing all four operations within the same lesson to see if I can combat the inaccurate generalizing that seems to occur.

The final observation is in the area of the demographic of the participants. I realize no teacher ever gets to stand in front of students who are truly clean slates. However, adult learners are so much *less* clean slates than the seventh graders I'm accustomed to. The research about fraction comprehension and understanding is vast, but very little relates to *re-teaching* these concepts to adults. Effective ideas for fifth graders who have never experienced rational numbers are helpful, but may not translate perfectly to the college classroom. When research does involve adults, it involves prospective teachers, not students. More research is needed if we hope to satisfactorily meet the needs of this important group of learners.

Effectively helping students learn how to understand and deal with rational numbers has been a foundation of research for decades. The Fractions for Welders curriculum involved unconventional methods for teaching and learning how to perform basic operations with fractions. Fraction division was a topic at the core of the project but the extent of the plan extended beyond just one operation. The aim was to analyze the success of a unique curriculum, originally developed for adolescents, when modified and implemented in a technical college classroom containing second-semester welding students. Based on the results of the pre- and post-tests there is evidence to support the curriculum had a positive impact on the welding students. Student growth and understanding was observed; yet, further adjustments could still be made to create a more effective unit on rational numbers.

Chapter 6

References

- Bloom, B. S., Engelhart, M.D., Furst, E. J., Hill, W. H., & Krathwohl, D.R. (1956). Taxonomy of educational objectives: the classification of educational goals; Handbook I: Cognitive Domain. New York: Longman.
- BrainPOP*. Retrieved March 13, 2012, from www.brainpop.com
- Bulgar, S. (2009). A Longitudinal Study of Students' Representations for Division of Fractions. The Montana Mathematics Enthusiast, 6(1&2), 165-200.
- Chasan, R. (2009). Practical Problems in Mathematics: For Welders. Clifton Park: Delmar.
- Dreyfus, T. & Eisenberg, T. (1990). Conceptual Calculus: Fact or Fiction? Teaching Mathematics and its Application, 9, 63-67.
- Ewen, D., & Nelson, C. R. (2011). Applied College Mathematics: for Math 373. Mason: Cengage Learning.
- Farnsworth, S. (2010). Welding For Dummies. Hoboken: Wiley Publishing, Inc.
- Forrester, P.A., & Chinnappan, M. (2010). The Predominance of Procedural Knowledge in Fractions. In L. Sparrow, B. Kissane, & C. Hurst (Eds.) (2010). *Shaping the future of mathematics education* (Proceedings of the 33rd annual conference of the Mathematics Education Research Group of Australasia, pp. 185-192). Fremantle, WA: MERGA.
- Hunter, M.C. (1982). Mastery Teaching. Thousand Oaks: Corwin.
- Kadijević, D. (1999). Conceptual Tasks in Mathematics Education. The Teaching of Mathematics, 2(1), 59-64.
- Lappan, G., Fey, J. T., Fitzgerald, W. M., Friel, S. N., & Phillips, E. D. (2004). Bits and Pieces II: Using Rational Numbers: Teacher's Guide. Needham: Pearson Prentice Hall.

- Ma, L. (1999). Knowing and Teaching Elementary Mathematics: Teachers' Understanding of Fundamental Mathematics in China and the United States. New Jersey: Lawrence Erlbaum Associates, Inc.
- Marion, N. (2006). Math for Welders. Tinley Park: The Goodheart-Willcox Company, Inc.
- Newton, K. J. & Sands, J. (2012). Why Don't We Just Divide Across? Mathematics Teaching in the Middle School, 17(6), 340-345.
- Online Stopwatch*. Retrieved March 13, 2012, from www.online-stopwatch.com
- Salinas, T. (2009). Beyond the Right Answer: Exploring How Preservice Elementary Teachers Evaluate Student-Generated Algorithms. The Mathematics Educator, 19(1), 27-34.
- Sharp, J. & Adams, B. (2002). Children's Constructions of Knowledge for Fraction Division After Solving Realistic Problems. The Journal of Educational Research, 95(6), 333-347.
- Skemp, R. R. (2006). Relational Understanding and Instrumental Understanding. Mathematics Teaching in the Middle School, 12(2), 88-95.
- Son, J. & Crespo, S. (2009). Prospective Teachers' Reasoning and Response to a Student's Non-traditional Strategy When Dividing Fractions. Journal of Mathematics Teacher Education, 12, 235-261.
- Tirosh, D. (2000). Enhancing Prospective Teachers' Knowledge of Children's Conceptions: The Case of Division of Fractions. Journal for Research in Mathematics Education, 31(1), 5-25.

Appendix A

Holiday Bows

- (1) Red ribbon comes packaged in 6 meter lengths;
- (2) Gold ribbon comes packaged in 3 meter lengths;
- (3) Blue ribbon comes packaged in 2 meter lengths;
- (4) White ribbon comes packaged in 1 meter lengths.

Bows require pieces of ribbon that are different lengths. Your job is to find out how many bows of particular lengths can be made from the packaged lengths for each color ribbon.

I. White Ribbon	Ribbon Length of Bow	Number of Bows
1 meter	$\frac{1}{2}$ meter	
1 meter	$\frac{1}{3}$ meter	
1 meter	$\frac{1}{4}$ meter	
1 meter	$\frac{1}{5}$ meter	
II. Blue Ribbon	Ribbon Length of Bow	Number of Bows
2 meters	$\frac{1}{2}$ meter	
2 meters	$\frac{1}{3}$ meter	
2 meters	$\frac{1}{4}$ meter	
2 meters	$\frac{1}{5}$ meter	
2 meters	$\frac{2}{3}$ meter	
III. Gold Ribbon	Ribbon Length of Bow	Number of Bows
3 meters	$\frac{1}{2}$ meter	
3 meters	$\frac{1}{3}$ meter	
3 meters	$\frac{1}{4}$ meter	
3 meters	$\frac{1}{5}$ meter	
3 meters	$\frac{2}{3}$ meter	
3 meters	$\frac{3}{4}$ meter	
IV. Red Ribbon	Ribbon Length of Bow	Number of Bows
6 meters	$\frac{1}{2}$ meter	
6 meters	$\frac{1}{3}$ meter	
6 meters	$\frac{1}{4}$ meter	
6 meters	$\frac{1}{5}$ meter	
6 meters	$\frac{2}{3}$ meter	
6 meters	$\frac{3}{4}$ meter	

(Bulgar, 2009, p. 174).

Appendix B

Tuna Sandwiches

Mr. Tastee's restaurant serves four different kinds of sandwiches. A junior sandwich contains $\frac{1}{4}$ lb of tuna; a regular sandwich contains $\frac{1}{3}$ lb of tuna; a large sandwich contains $\frac{1}{2}$ lb of tuna and a hero sandwich contains $\frac{2}{3}$ lb of tuna. Tuna comes in cans that are 1lb, 2lb, 3lb and 5lb. How many of each type of sandwich can you make from each size can? Find a clear way to record your information. You will need to write a letter to the restaurant owner, Mr. Tastee, and give him your findings (Bulgar, 2009, p. 175).

Appendix C

Fractions for Welders Pre-Test

NAME _____

Please indicate whether or not you used a calculator for each problem.



1. Read the distances from the start of this steel tape measure to the letters:

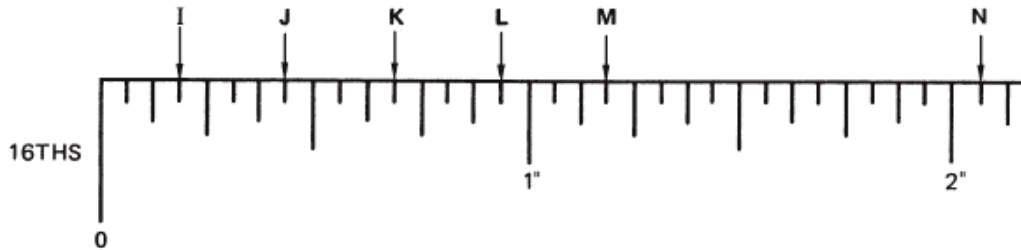

2. How many fourths are in 1 whole? How many fourths are in 2 wholes?
How many fourths are in 17 wholes?

3. Find the total combined weight of these three pieces of steel:

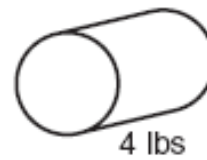
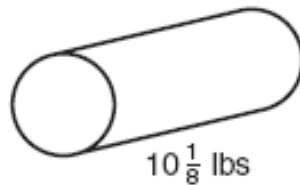
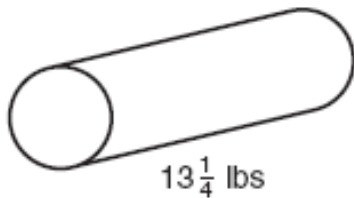

4. Determine the missing dimension:

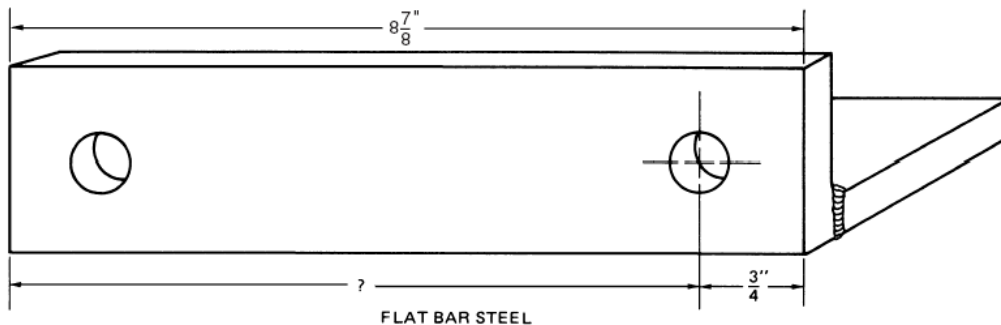

5. Five steel bars, each $6 \frac{1}{2}$ " long, are welded together; how long will the new bar be?

6. Divide a $38 \frac{1}{8}$ " piece of mild steel into 6 equal parts. What is the length of 3 parts when welded together?

1. Read the distances from the start of this steel tape measure to the letters:

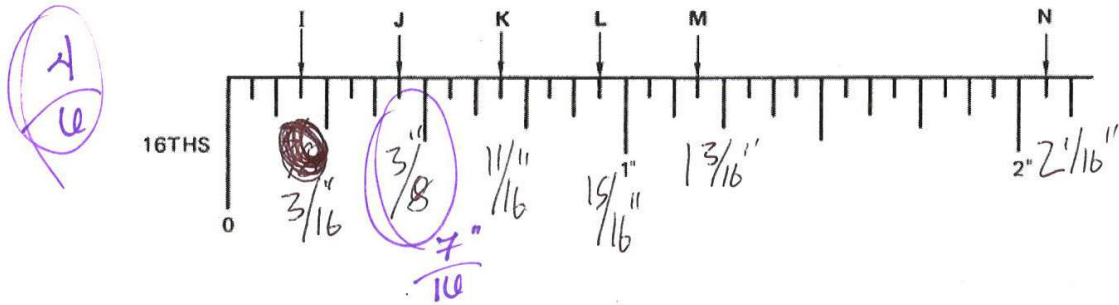

2. How many fourths are in 1 whole? How many fourths are in 2 wholes?
How many fourths are in 17 wholes?

4, 8, 68

3. Find the total combined weight of these three pieces of steel:

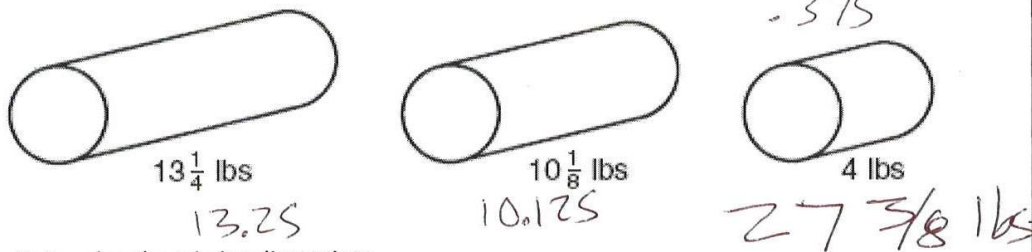

4. Determine the missing dimension:

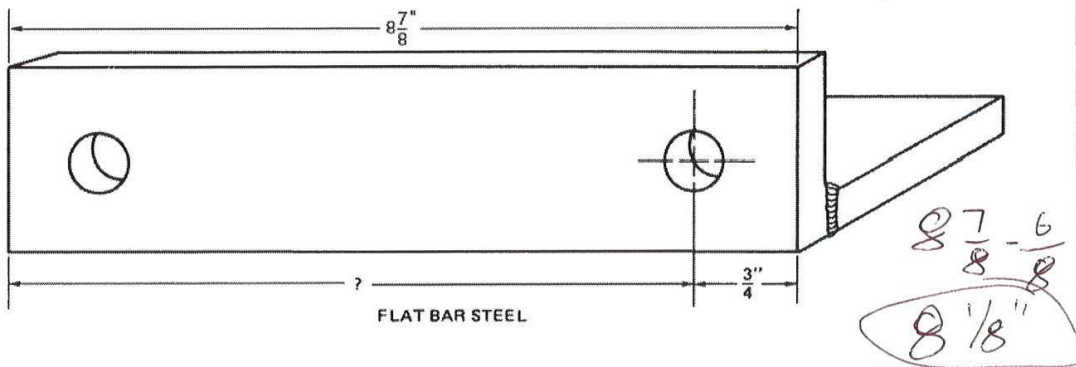

5. Five steel bars, each $6 \frac{1}{2}$ inches long, are welded together; how long will the new bar be?

$32 \frac{1}{2}$ inches

6. Divide a $38 \frac{1}{8}$ inch piece of mild steel into 6 equal parts. What is the length of 3 parts when welded together?

12.7 inches

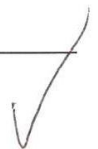

1. Read the distances from the start of this steel tape measure to the letters:

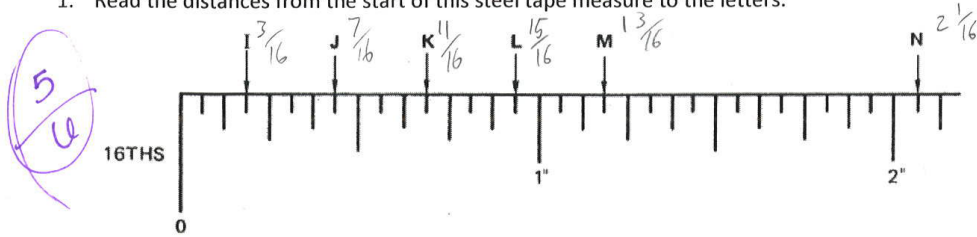

2. How many fourths are in 1 whole? How many fourths are in 2 wholes?
 How many fourths are in 17 wholes? 4 fourths in one whole,
 8 fourths in 2 wholes, 68 fourths in 17 wholes

3. Find the total combined weight of these three pieces of steel:

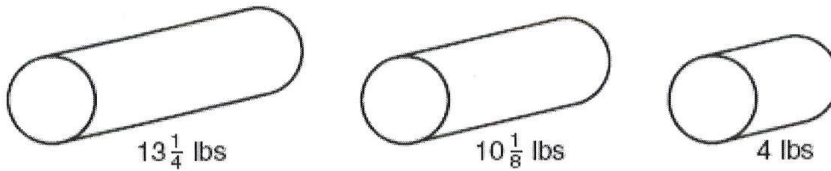

4. Determine the missing dimension:

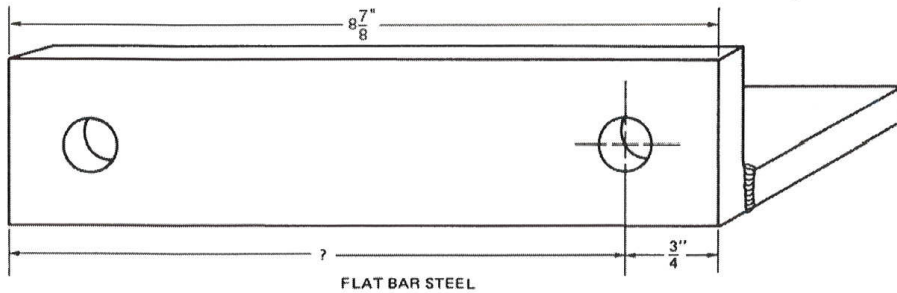

5. Five steel bars, each 6 1/2" long, are welded together; how long will the new bar be?

~~6.~~ Divide a 38 1/8" piece of mild steel into 6 equal parts. What is the length of 3 parts when welded together?

4x17 = 68	
27 3/8 lbs.	
	8 1/8"
	32.5"

1. Read the distances from the start of this steel tape measure to the letters:

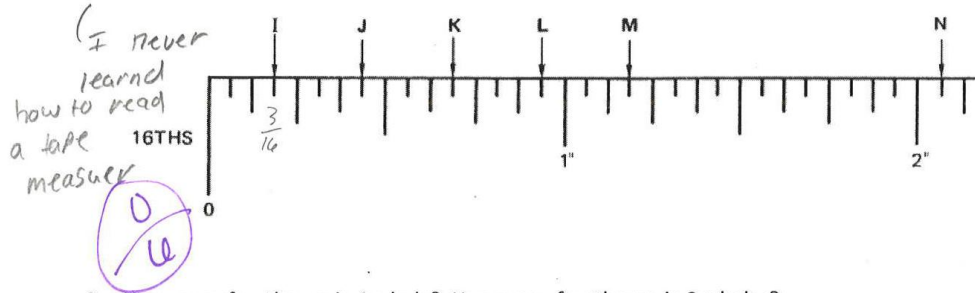

2. How many fourths are in 1 whole? How many fourths are in 2 wholes?
How many fourths are in 17 wholes?

- I don't know how to attack it.

3. Find the total combined weight of these three pieces of steel:

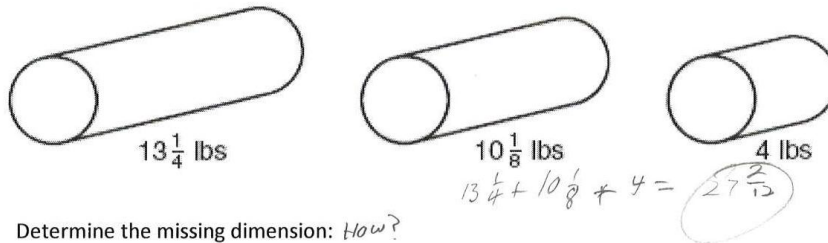

4. Determine the missing dimension: *How?*

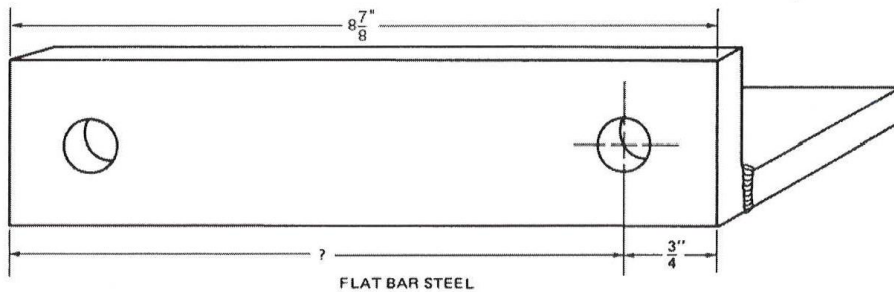

5. Five steel bars, each $6\frac{1}{2}$ " long, are welded together; how long will the new bar be?

6. Divide a $38\frac{1}{8}$ " piece of mild steel into 6 equal parts. What is the length of 3 parts when welded together?



✓	

1. Read the distances from the start of this steel tape measure to the letters:

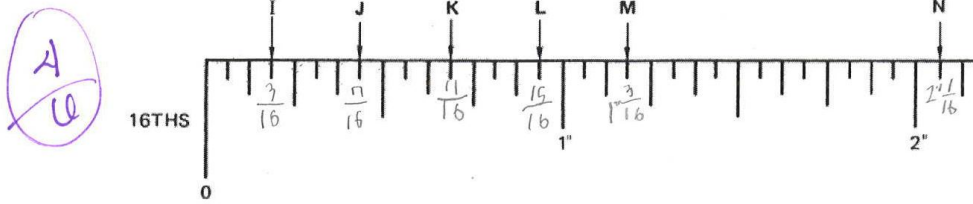

2. How many fourths are in 1 whole? How many fourths are in 2 wholes? $4 = 1$ $8 = 2$
 How many fourths are in 17 wholes? $68 = 17$

$$\begin{array}{r} 317 \\ \times 4 \\ \hline 68 \end{array}$$

3. Find the total combined weight of these three pieces of steel:

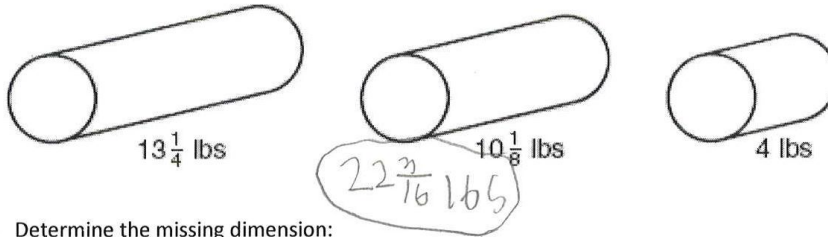

4. Determine the missing dimension:

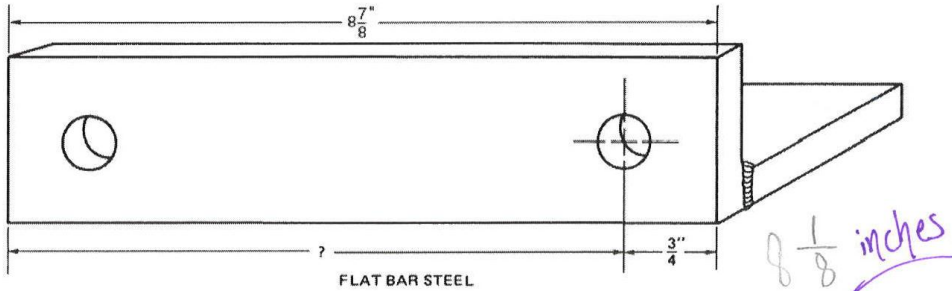

5. Five steel bars, each $6\frac{1}{2}$ " long, are welded together; how long will the new bar be?

$$6\frac{1}{2} \times 5 = 32\frac{1}{2} \text{ long}$$

6. Divide a $38\frac{1}{8}$ " piece of mild steel into 6 equal parts. What is the length of 3 parts when welded together?

$$38\frac{1}{8} \div 6 = 6\frac{1}{8} \text{ } 2\frac{3}{8}$$

		X
		X
		X
		X
		X

1. Read the distances from the start of this steel tape measure to the letters:

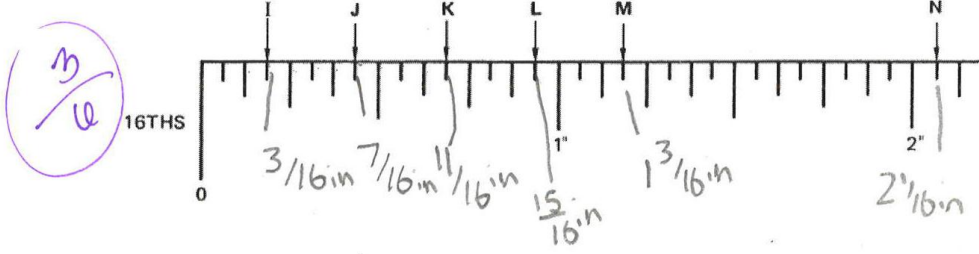

2. How many fourths are in 1 whole? How many fourths are in 2 wholes?
How many fourths are in 17 wholes? 4 8 68

$$217 \times \frac{1}{68}$$

3. Find the total combined weight of these three pieces of steel:

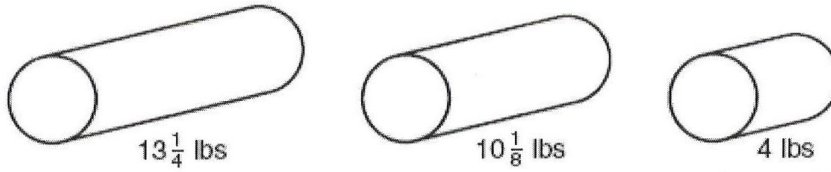

4. Determine the missing dimension:

$$\frac{1}{4} + \frac{1}{8} \times \frac{2}{8} + \frac{1}{6} = \frac{3}{8}$$

$27 \frac{3}{8}$ lbs

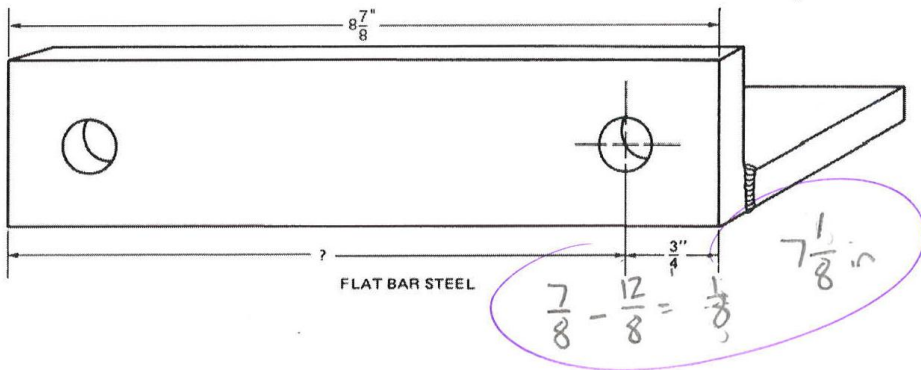

5. Five steel bars, each $6 \frac{1}{2}$ " long, are welded together; how long will the new bar be?

$8 \frac{1}{2}$ long

6. Divide a $38 \frac{1}{8}$ " piece of mild steel into 6 equal parts. What is the length of 3 parts when welded together?

$$\frac{1}{8} \times \frac{3}{1}$$

$12 \frac{17}{24}$ in

		X
		X
		X
		X
		X
		X

1. Read the distances from the start of this steel tape measure to the letters:

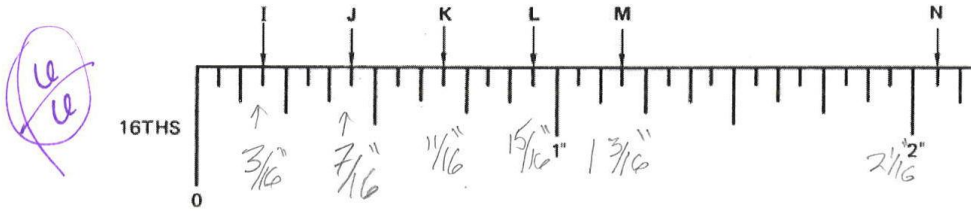

2. How many fourths are in 1 whole? How many fourths are in 2 wholes? How many fourths are in 17 wholes?

4
8
68

3. Find the total combined weight of these three pieces of steel:

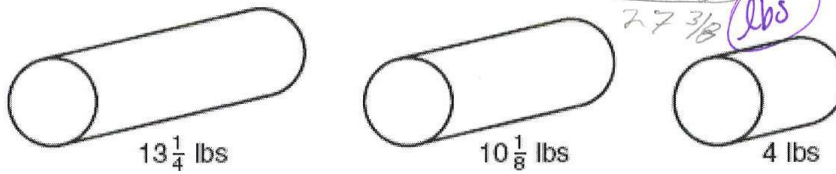

4
13 1/4
10 1/8
27 3/8 lbs

4. Determine the missing dimension:

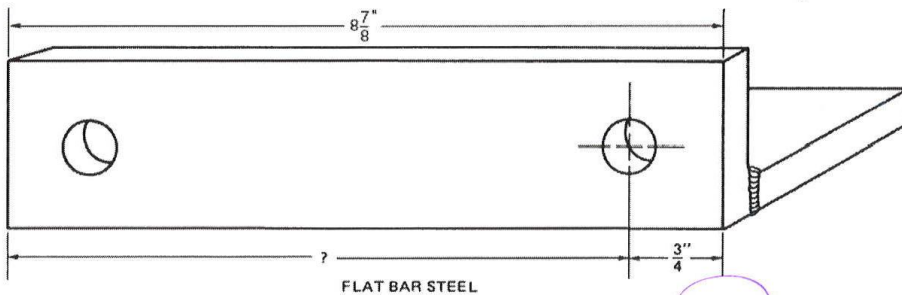

8 7/8 - 3/4 = 8 1/8 inches

5. Five steel bars, each 6 1/2" long, are welded together; how long will the new bar be?

32 1/2 inches

6. Divide a 38 1/8" piece of mild steel into 6 equal parts. What is the length of 3 parts when welded together?

38 1/8 ÷ 6 = 6 17/48
6 17/48 × 3 = 19 1/16 inches

1. Read the distances from the start of this steel tape measure to the letters:

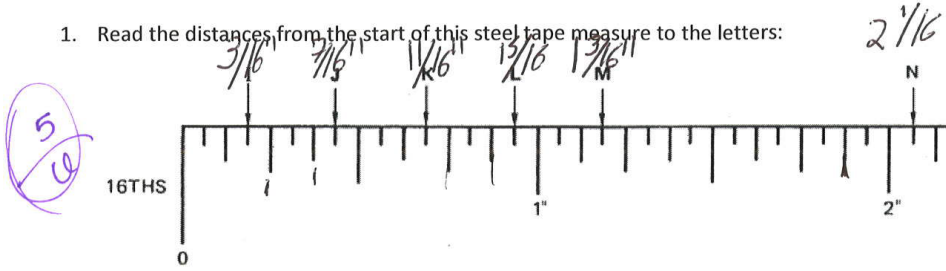

2. How many fourths are in 1 whole? How many fourths are in 2 wholes?
How many fourths are in 17 wholes?

Handwritten answers: 4 , 8 , 68 , $2 \frac{17}{4}$, 17 , 13 , 17 , 68

3. Find the total combined weight of these three pieces of steel:

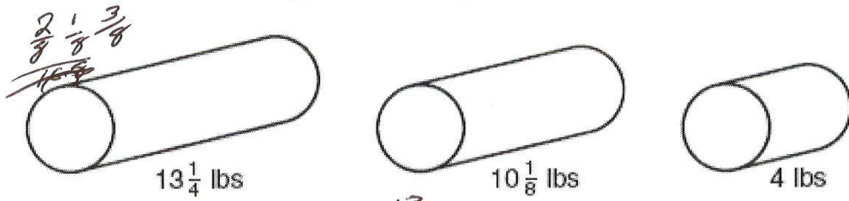

4. Determine the missing dimension:

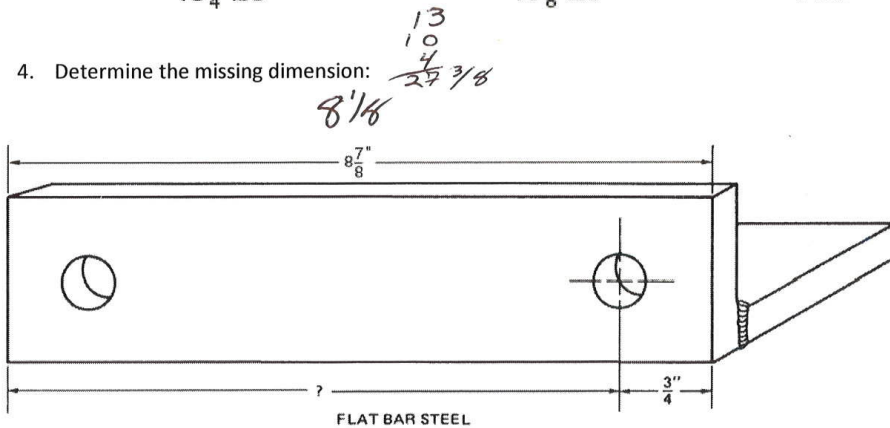

5. Five steel bars, each $6 \frac{1}{2}$ " long, are welded together; how long will the new bar be?

Handwritten answer: $32 \frac{1}{2}$ "

6. Divide a $38 \frac{1}{8}$ " piece of mild steel into 6 equal parts. What is the length of 3 parts when welded together?

Handwritten answer: 6.354

Handwritten notes: "close!", 6.354 , 19.062 (circled)

	4 8 68
	$27 \frac{3}{8}$ <u>lbs.</u>
	$8 \frac{1}{8}$ <u>inches.</u>
	$32 \frac{1}{2}$ "
	6.354 19.062 (circled)

1. Read the distances from the start of this steel tape measure to the letters:

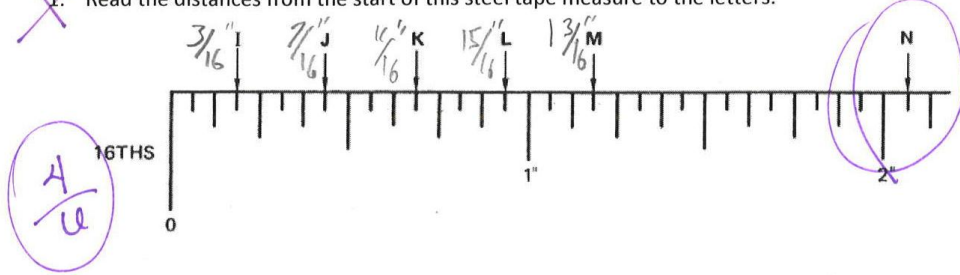

2. How many fourths are in 1 whole? How many fourths are in 2 wholes?
How many fourths are in 17 wholes?

1 whole = 4 2 wholes = 8 17 wholes = 68

3. Find the total combined weight of these three pieces of steel:

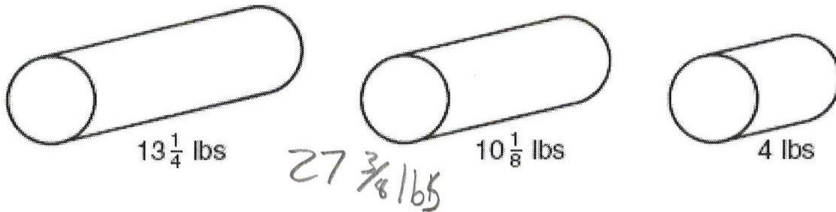

4. Determine the missing dimension:

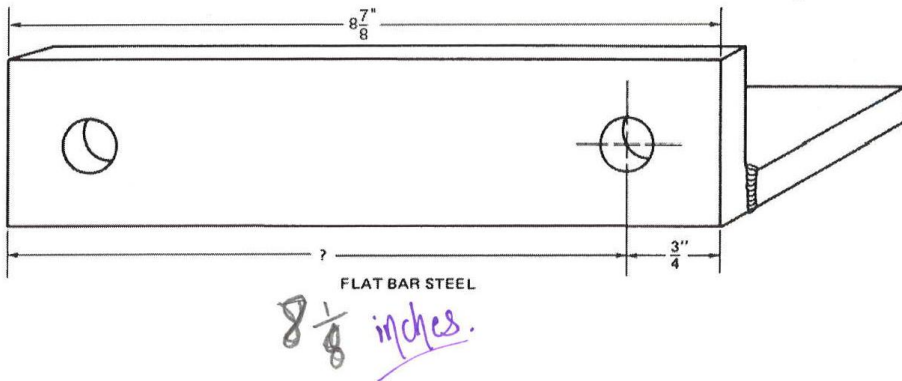

5. Five steel bars, each $6\frac{1}{2}$ " long, are welded together; how long will the new bar be?

$32\frac{1}{2}$ "

6. Divide a $38\frac{1}{8}$ " piece of mild steel into 6 equal parts. What is the length of 3 parts when welded together?

19.09375

		✓
		✓
		✓
		✓
		✓
		✓

1. Read the distances from the start of this steel tape measure to the letters:

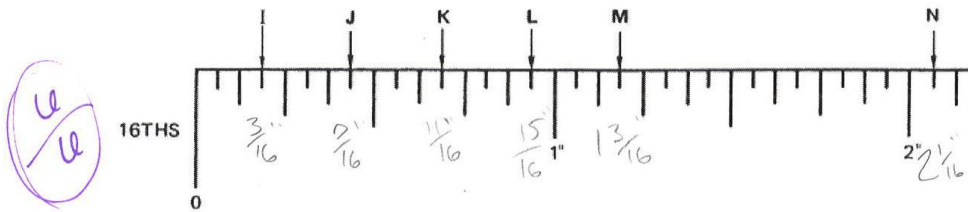

2. How many fourths are in 1 whole? How many fourths are in 2 wholes?
How many fourths are in 17 wholes?

4
8
68

3. Find the total combined weight of these three pieces of steel:

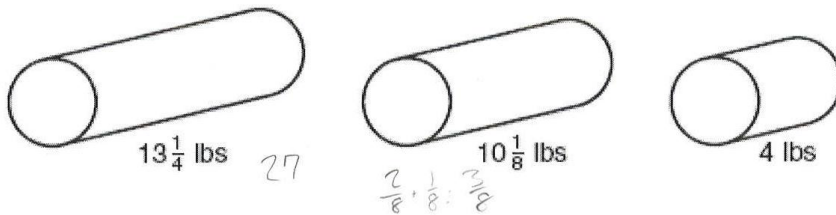

$27 \frac{3}{8}$
lbs.

4. Determine the missing dimension:

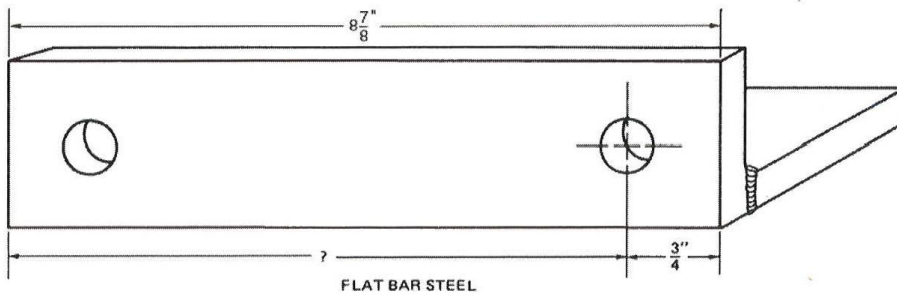

$8 \frac{1}{8}$
inches

5. Five steel bars, each $6 \frac{1}{2}''$ long, are welded together; how long will the new bar be?

$6.5 = 30$
 $\frac{1}{2} \cdot 5 = \frac{5}{2} = 2 \frac{1}{2}$

$32 \frac{1}{2}$
inches

6. Divide a $38 \frac{1}{8}''$ piece of mild steel into 6 equal parts. What is the length of 3 parts when welded together?

$6 \overline{) 38.125}$
 $\underline{18}$
 20
 $\underline{12}$
 8
 $\underline{6}$
 2

0.354
 $\underline{.354}$
 1.052

$19 \frac{1}{16}''$
or
19.0625

1. Read the distances from the start of this steel tape measure to the letters:

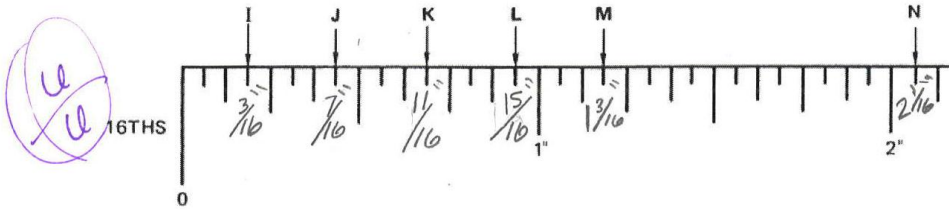

2. How many fourths are in 1 whole? How many fourths are in 2 wholes?
 How many fourths are in 17 wholes?

Handwritten answers:
 $4 \cdot \frac{1}{4}$ ths in 1 whole
 $8 \cdot \frac{1}{4}$ ths in 2 wholes
 $68 \cdot \frac{1}{4}$ ths in 17 wholes

Vertical calculation:

$$\begin{array}{r} 27 \\ 4 \\ \hline 108 \end{array}$$

3. Find the total combined weight of these three pieces of steel:

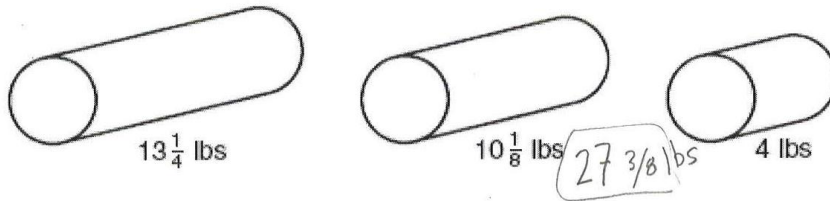

4. Determine the missing dimension:

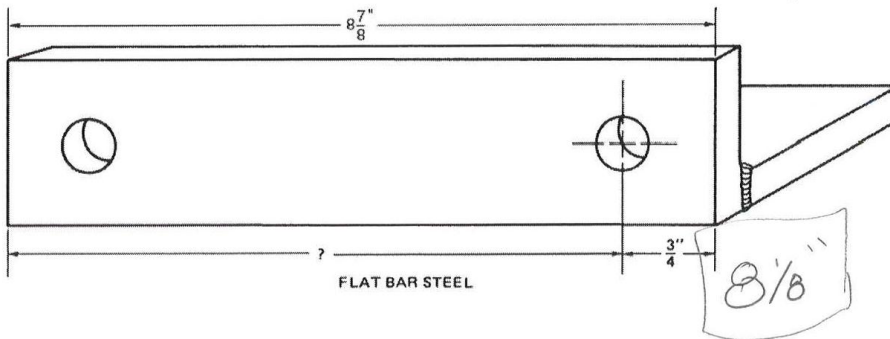

5. Five steel bars, each $6\frac{1}{2}$ " long, are welded together; how long will the new bar be?

Handwritten answer: 32.5" long

6. Divide a $38\frac{1}{8}$ " piece of mild steel into 6 equal parts. What is the length of 3 parts when welded together?

Handwritten calculation: $38\frac{1}{8}$ or $38.125 \div 6 = 6.354 \times 3 =$

w/calculator

Handwritten answer: 19.0625 inches

		✓
		✓
		✓
		✓
		✓
		✓

1. Read the distances from the start of this steel tape measure to the letters:

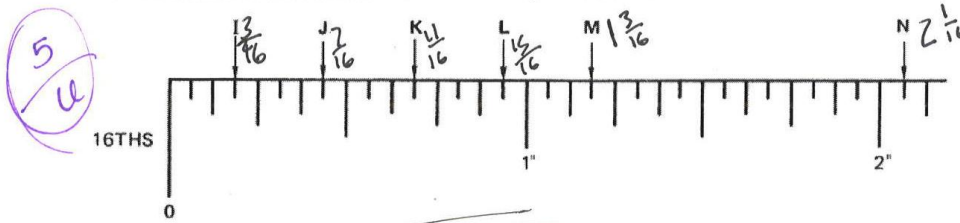

2. How many fourths are in 1 whole? How many fourths are in 2 wholes?
How many fourths are in 17 wholes?

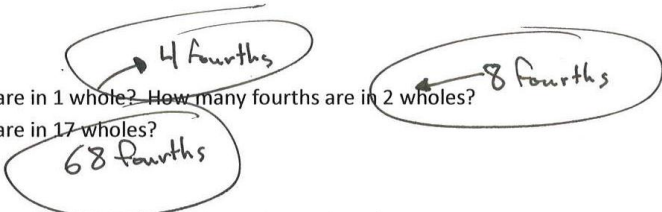

3. Find the total combined weight of these three pieces of steel:

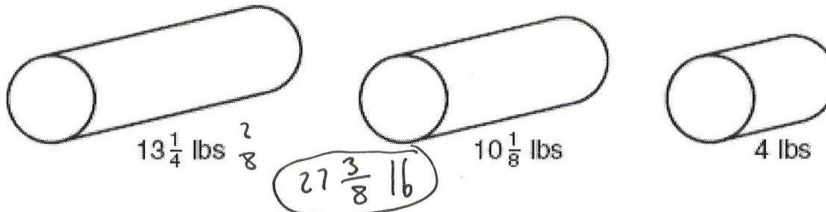

4. Determine the missing dimension:

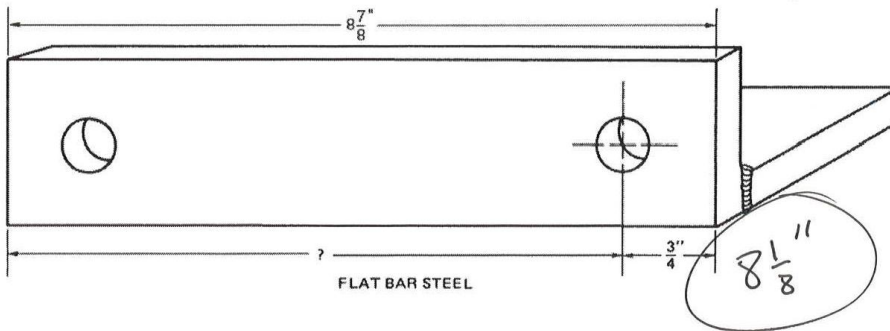

5. Five steel bars, each $6\frac{1}{2}$ " long, are welded together; how long will the new bar be?

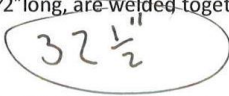

6. Divide a $38\frac{1}{8}$ " piece of mild steel into 6 equal parts. What is the length of 3 parts when welded together?

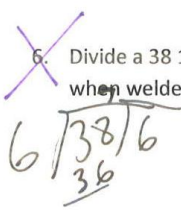

1. Read the distances from the start of this steel tape measure to the letters:

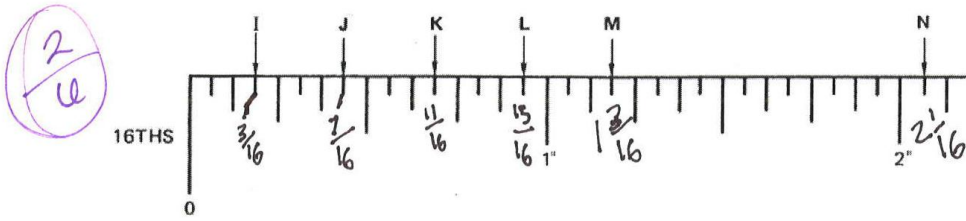

2. How many fourths are in 1 whole? How many fourths are in 2 wholes? How many fourths are in 17 wholes?

4, 8, 34

3. Find the total combined weight of these three pieces of steel:

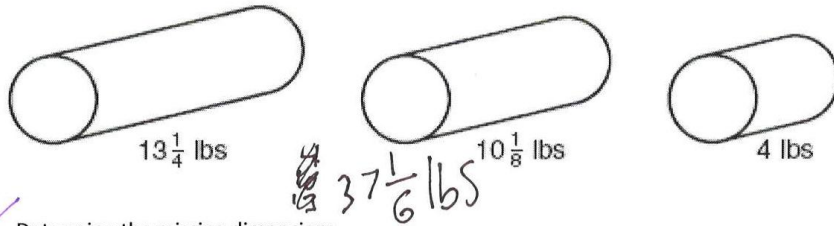

4. Determine the missing dimension:

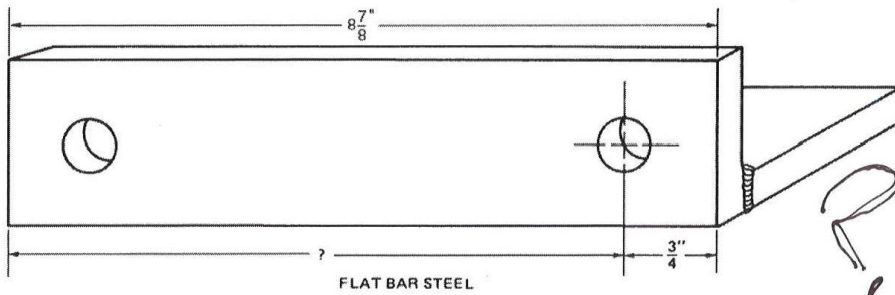

5. Five steel bars, each $6\frac{1}{2}$ " long, are welded together; how long will the new bar be?

32 1/2 inches

6. Divide a $38\frac{1}{8}$ " piece of mild steel into 6 equal parts. What is the length of 3 parts when welded together?

11

	✓
✓	✓
	✓
?	?
✓	✓
	✓

Appendix D

Town Map

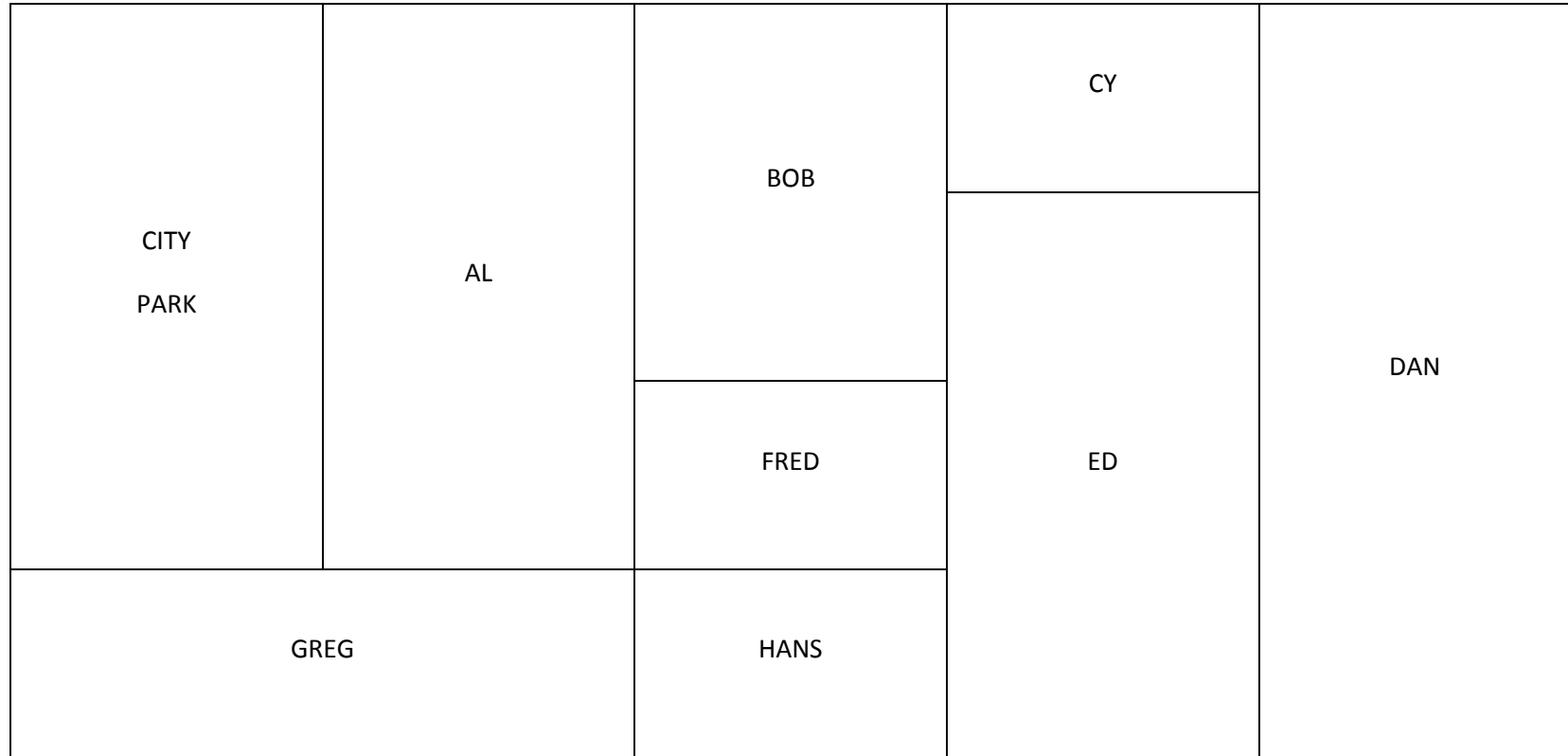

Names _____

AL _____

BOB _____

CY _____

DAN _____

ED _____

FRED _____

GREG _____

HANS _____

PARK _____

CITY PARK	AL	BOB	CY	DAN
		$\frac{2-1}{20-10}$	$\frac{1}{20}$	
$\frac{3}{20}$	$\frac{3}{20}$	FRED	ED	$\frac{1}{5}$
	GREG	HANS	$\frac{3}{20}$	
	$\frac{2-1}{20-10}$	$\frac{1}{20}$		

AL	$\frac{3}{20}$	BOB	$\frac{1}{10}$	CY	$\frac{1}{20}$
DAN	$\frac{1}{5}$	ED	$\frac{3}{20}$	FRED	$\frac{1}{20}$
GREG	$\frac{1}{10}$	HANS	$\frac{1}{20}$	PARK	$\frac{3}{20}$

AL	$\frac{3}{20}$	BOB	$\frac{1}{10}$	CY	$\frac{1}{20}$
DAN	$\frac{1}{5}$	ED	$\frac{3}{20}$	FRED	$\frac{1}{20}$
GREG	$\frac{1}{10}$	HANS	$\frac{1}{20}$	PARK	$\frac{3}{20}$

CITY PARK	AL	BOB	CY	DAN
		FRED	ED	
GREG		HANS		

AL $\frac{1}{10}$	BOB $\frac{1}{10}$	CY $\frac{1}{20}$
DAN $\frac{1}{5}$	ED $\frac{3}{20}$	FRED $\frac{1}{20}$
GREG $\frac{1}{10}$	HANS $\frac{1}{20}$	PARK $\frac{3}{10}$

AL $\frac{3}{20}$	BOB $\frac{1}{10}$	CY $\frac{1}{20}$
DAN $\frac{1}{5}$	ED $\frac{3}{20}$	FRED $\frac{1}{20}$
GREG $\frac{2}{20} = \frac{1}{10}$	HANS $\frac{1}{20}$	PARK $\frac{3}{20}$

AL $\frac{3}{20}$	BOB $\frac{1}{10}$	CY $\frac{1}{20}$
DAN $\frac{1}{5}$	ED $\frac{3}{20}$	FRED $\frac{1}{20}$
GREG $\frac{1}{10}$	HANS $\frac{1}{20}$	PARK $\frac{3}{20}$

Appendix E

Learning Targets

There are seven learning targets (objectives written from the point of view of a student) associated with the Fractions for Welders curriculum unit. The learning targets are consistent with the Course Outcome Summary for Math 373 as outlined by Wisconsin Indianhead Technical College (WITC). The specific learning targets are outlined below.

- I can find equivalent fractions by multiplying a given fraction by a "version of 1".
- I can simplify a given fraction by dividing it by an appropriate "version of 1".
- I can rewrite a mixed number as an improper fraction (and vice versa).
- I can multiply fractions.
- I can divide fractions (even if I have to use "Plan B").
- I can add fractions.
- I can subtract fractions.

Appendix F

BrainPOP Quiz 1

1 What is the easiest way to convert a mixed number to a fraction?

- A** Multiply the denominator by the whole number, then add your result to the numerator
- B** Multiply the numerator by the whole number, then add your result to the denominator
- C** Add the numerator and the whole number together, then place your result over the denominator
- D** Find the least common denominator of the whole number and the denominator, and then multiply

2 A recipe calls for $3 \frac{3}{8}$ cups of flour. How can you express that number as a fraction?

- A** $\frac{6}{8}$
- B** $\frac{8}{27}$
- C** $\frac{27}{8}$
- D** $\frac{14}{8}$

3 $14/10$ is:

- A** An immodest fraction
- B** An improper fraction
- C** An unpopular fraction
- D** A mixed fraction

4 How can you express $2 \frac{2}{10}$ as a fraction?

- A** $10/22$
- B** $22/10$
- C** $1/2$
- D** $14/10$

5 What is $2\frac{1}{4} + 3\frac{1}{4}$?

A $5\frac{1}{4}$

B $6\frac{1}{2}$

C $6\frac{1}{4}$

D $5\frac{1}{2}$

6 What is the mixed number $4\frac{1}{5}$ as a sum of two fractions?

A $\frac{20}{5} + \frac{1}{5}$

B $\frac{4}{5} + \frac{1}{5}$

C $\frac{4}{4} + \frac{1}{5}$

D $\frac{5}{4} + \frac{1}{5}$

7 Convert the fraction $21/6$ into a mixed number.

A $5 \frac{1}{4}$

B $21 \frac{1}{6}$

C $3 \frac{1}{2}$

D $6 \frac{1}{6}$

8 What is $3 \frac{2}{5} + 2 \frac{1}{10}$?

A $5 \frac{3}{10}$

B $5 \frac{3}{5}$

C 6

D $5 \frac{1}{2}$

9 What is the mixed number that results from $\frac{3}{2} + \frac{2}{2}$?

A $2 \frac{1}{2}$

B $2 \frac{1}{5}$

C $3 \frac{1}{2}$

D $4 \frac{1}{2}$

10 What is the mixed number that results from $\frac{5}{4} + \frac{2}{8}$?

A $2 \frac{1}{4}$

B $4 \frac{5}{8}$

C $1 \frac{1}{2}$

D $2 \frac{5}{8}$

Appendix G

BrainPOP Quiz 2

1 What is the multiplicative inverse of $\frac{1}{4}$?

- A** $\frac{1}{8}$
- B** $\frac{8}{1}$
- C** 4
- D** $\frac{1}{2}$

2 Which of the following is a step in multiplying $\frac{3}{4}$ by $\frac{3}{5}$?

- A** Adding 3 and 3
- B** Finding the lowest common denominator of 4 and 5
- C** Multiplying 3 and 3
- D** Multiplying 3 and 5

3

Two-thirds of Tim's class has cupcakes. One half of the cupcakes have chocolate frosting. What fraction of students have cupcakes with chocolate frosting?



A

$1/6$

B

$1/3$

C

$1/2$

D

$1/4$

4

$1/5$ multiplied by what number will result in a product of $1/10$?

A

$1/2$

B

2

C

$1/5$

D

5

5 $\frac{1}{5}$ divided by what number will result in a quotient of 2?

A 10

B $\frac{1}{10}$

C 5

D $\frac{1}{5}$

6 $\frac{2}{5}$ of the TV shows Moby watches are police shows, and $\frac{1}{3}$ of them are set in New York City. What fraction of the shows Moby watches are police shows set in New York City?

A $\frac{3}{15}$

B $\frac{1}{15}$

C $\frac{1}{5}$

D $\frac{2}{15}$

7 What is $\frac{3}{8}$ divided by $\frac{4}{5}$?

A $\frac{7}{13}$

B $\frac{12}{40}$

C $\frac{15}{32}$

D $\frac{8}{12}$

8 Cassie is baking cookies from scratch. Her recipe calls for $\frac{7}{8}$ of a cup of sugar per batch. If she is baking just $\frac{2}{3}$ of a batch of cookies, how much sugar should she use?

A $\frac{2}{3}$ cup

B $\frac{9}{11}$ cup

C $\frac{7}{12}$ cup

D $\frac{16}{21}$ cup

9 If a turtle moves at $1\frac{1}{3}$ kilometers per hour, how long would it take the turtle to travel 9 kilometers?



A $6\frac{3}{4}$ hours

B 12 hours

C 10 hours

D $8\frac{1}{2}$ hours

10 What is $1\frac{3}{4}$ divided by 2?

A $\frac{7}{8}$

B $\frac{14}{4}$

C $\frac{1}{2}$

D 3

Appendix H

Lesson Two Exit Slip

PLACE AN "X" NEXT TO ANY STATEMENT THAT IS TRUE.

_____ I prefer working with decimal numbers over fractions.

_____ I didn't realize I could "divide straight across" until today.

_____ I remember being told (by a former teacher or other adult) not to "divide straight across".

_____ I prefer working with fractions over decimal numbers.

_____ I make more mistakes working with fractions than working with whole numbers.

_____ I understand how to use the fraction tools available on my calculator.

_____ I am better at adding/subtracting fractions than multiplying/dividing fractions.

_____ I am better at multiplying/dividing fractions than adding/subtracting fractions.

Appendix I

Lesson Three Team Challenge

Calculate dimensions for (A), (B), (C), and (D).

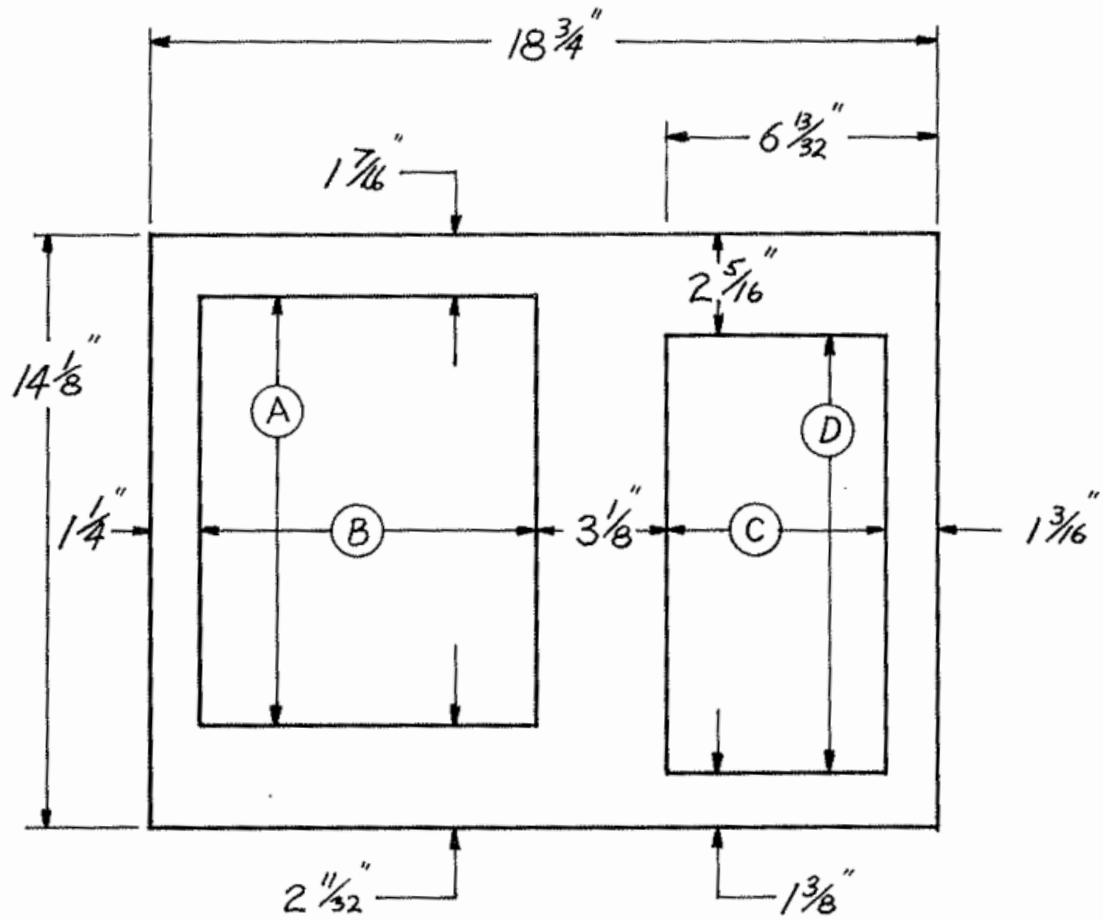

Appendix J

Lesson Three Exit Slip

NAMES _____

1

Calculate the following lengths.

- (a) The total of the vertical lengths.
- (b) The total of the horizontal lengths.
- (c) The total of the angular lengths.

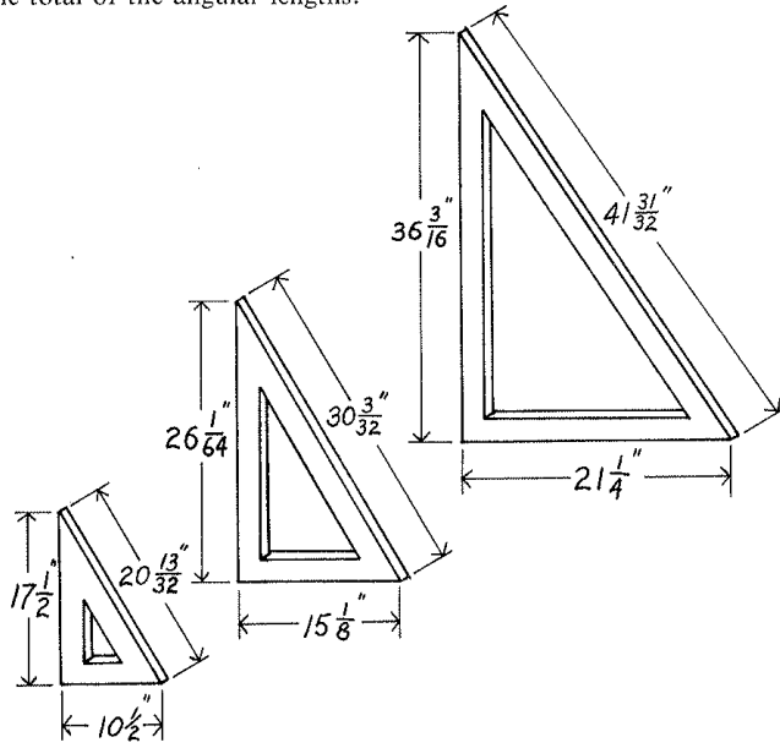

Calculate the overall length of this test bar after welding.

2

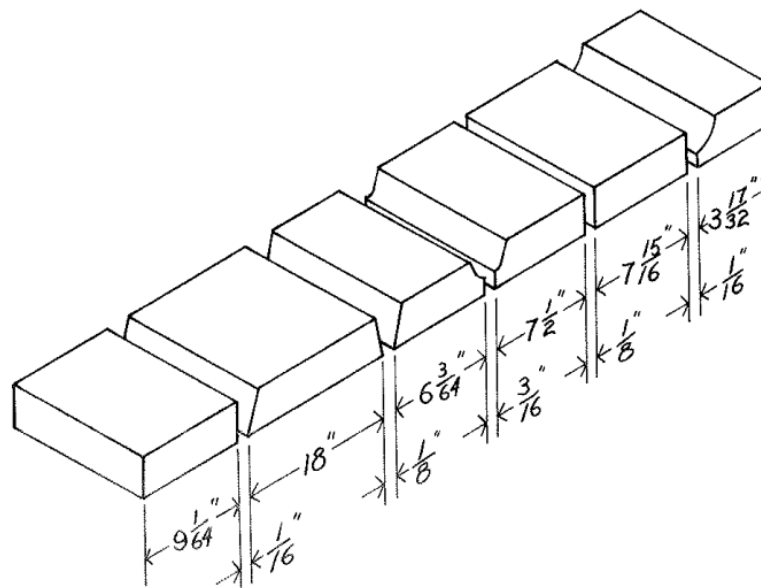

3

A flame-cut wheel is to have the shape shown. Find the missing dimension.

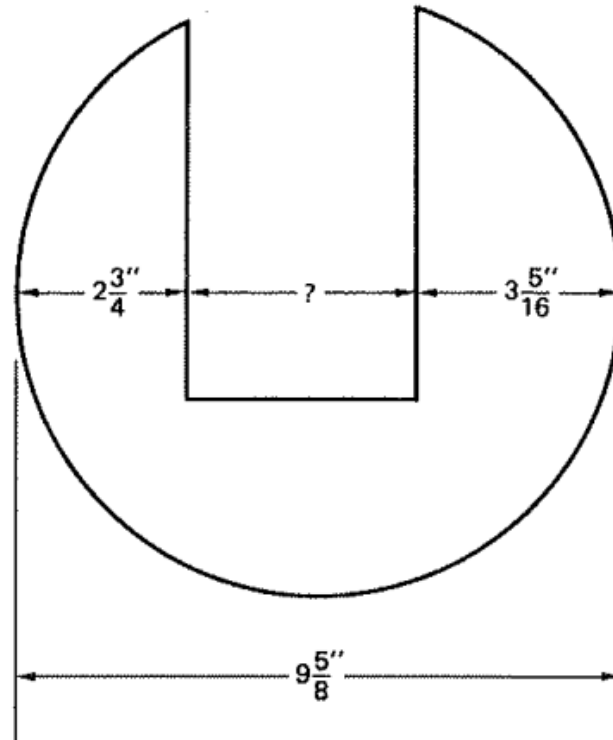
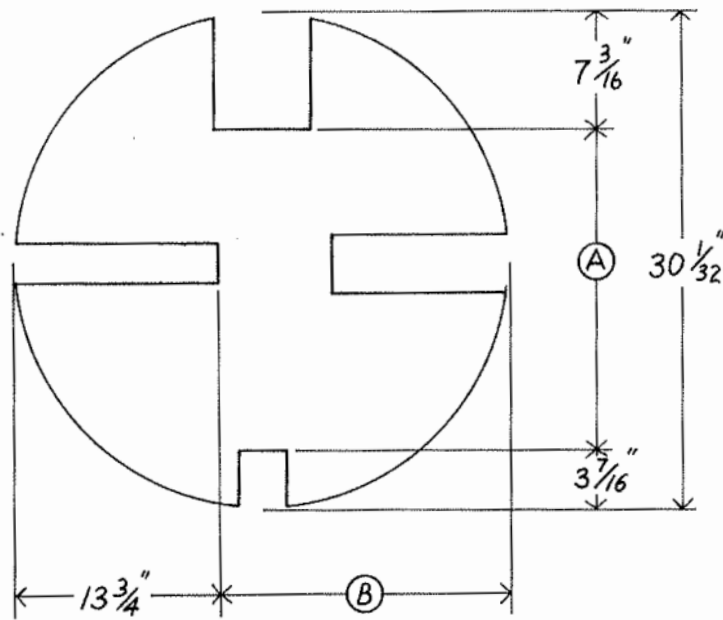

PLATE STEEL

4

Slots are cut from the circular piece as shown. Calculate dimension (A) and dimension (B).



5

Find length (A).

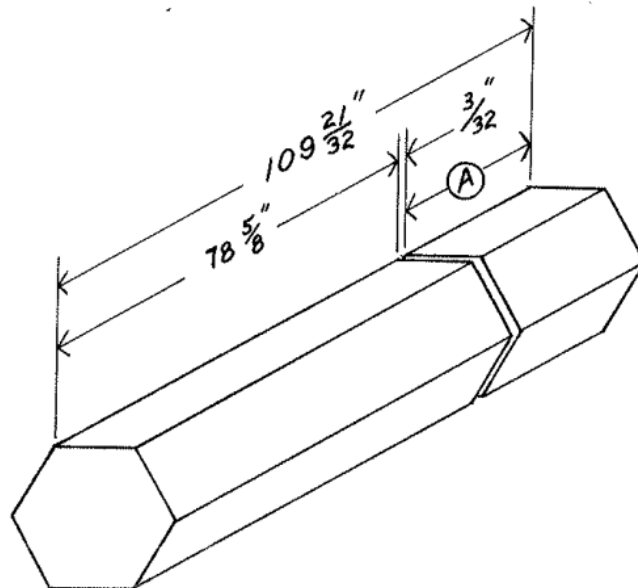

Appendix K

Lesson Three Independent Practice

1. Find the total combined length of these 2 pieces of bar stock. _____

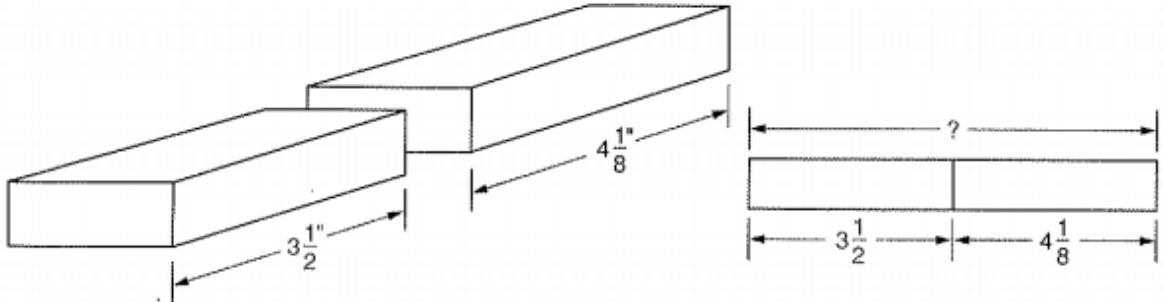

2. If you stack the 2 pieces of steel bar, what is the height of the stack? _____

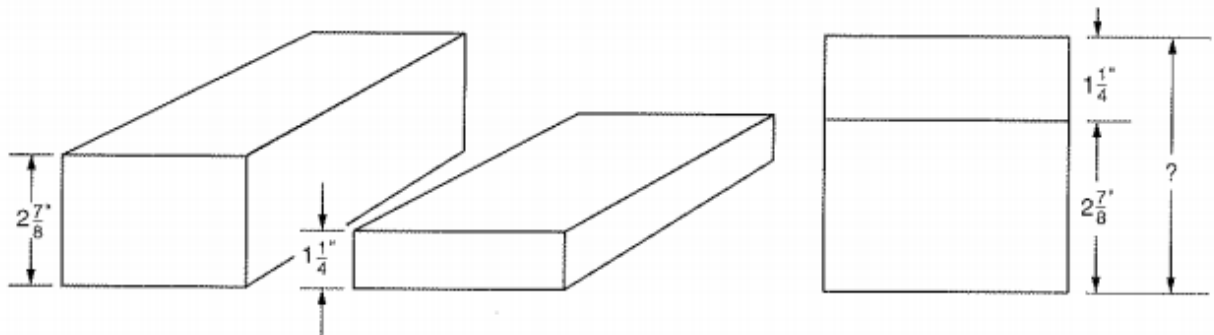

3. Find the total combined weight of these 3 pieces of steel. _____

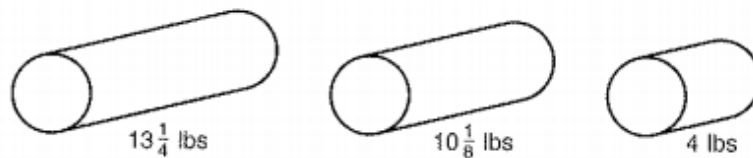

4. Four holes are drilled in this piece of flat stock. What is the total distance between the centers of the holes? _____

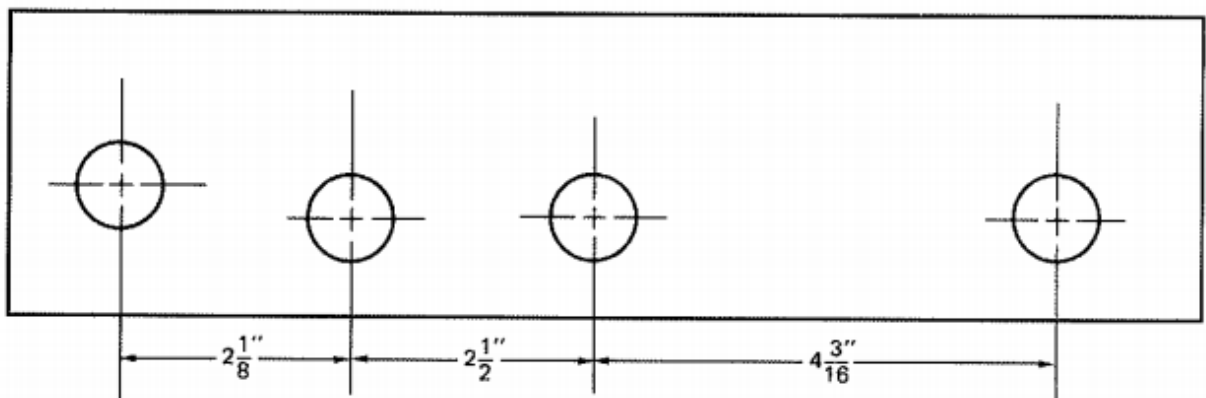

5. Two circular pieces of steel are placed side by side. What is their combined length? _____

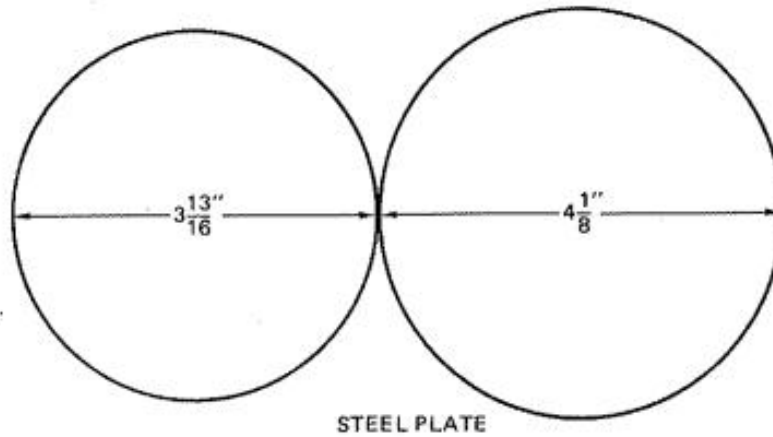

6. What is the length of this weldment? _____

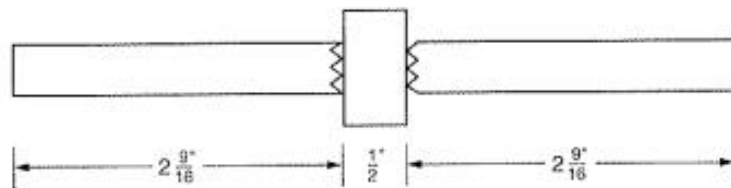

7. To make shims for leveling a shear, three pieces of material are welded together. What is the total thickness of the welded material, in inches? _____

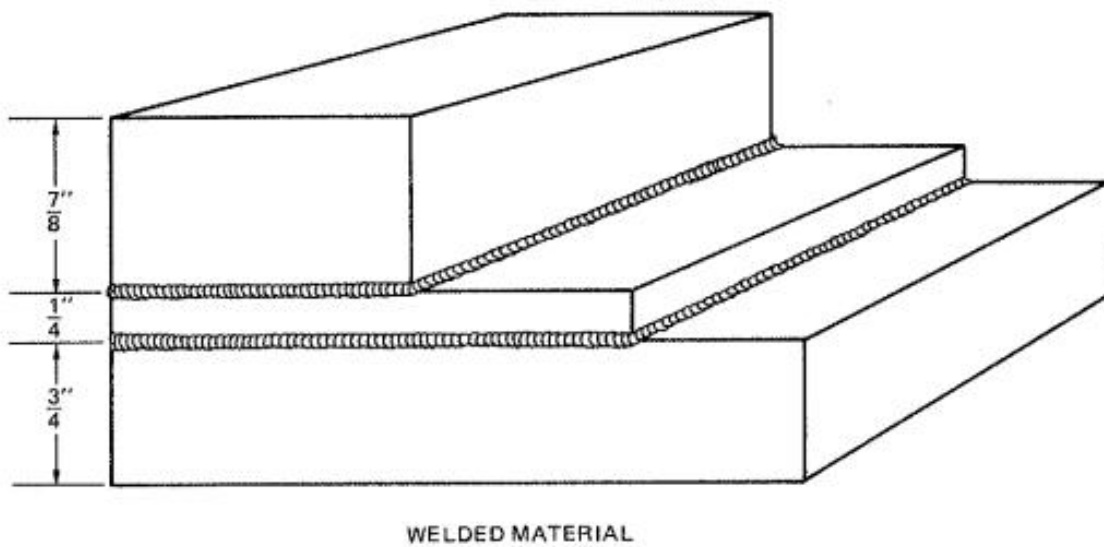

8

A $3\frac{1}{16}$ " piece is cut from the steel angle iron illustrated. If there is $\frac{1}{8}$ " of waste caused by the kerf of the oxy-acetylene cutting process, what is the length of the remaining piece of angle iron?

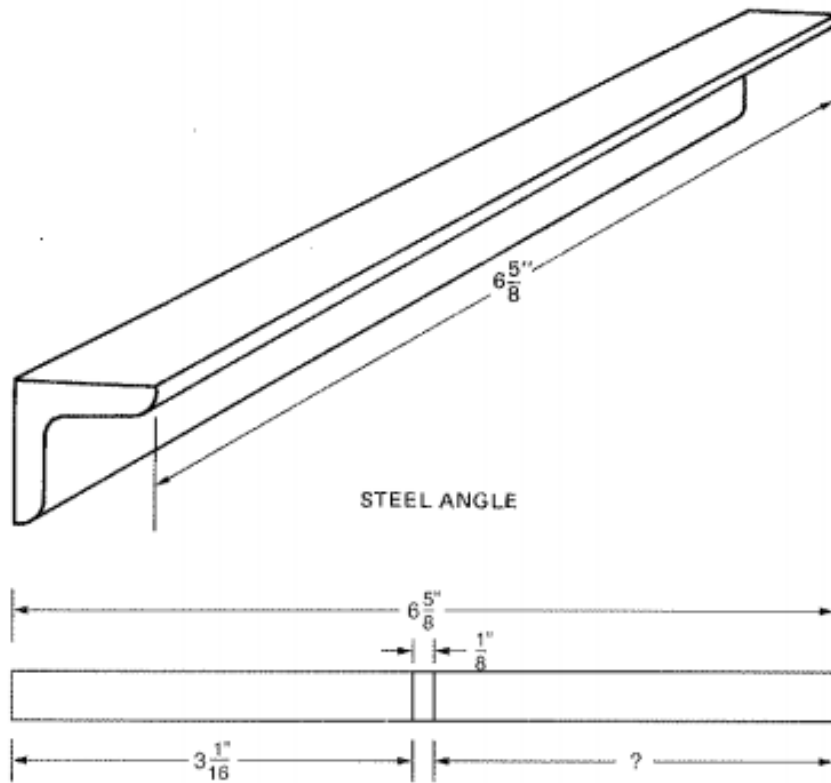

9

A $9\frac{5}{16}$ " length of bar stock is cut from this piece. What is the length of the remaining bar stock? Disregard waste caused by the width of the kerf.

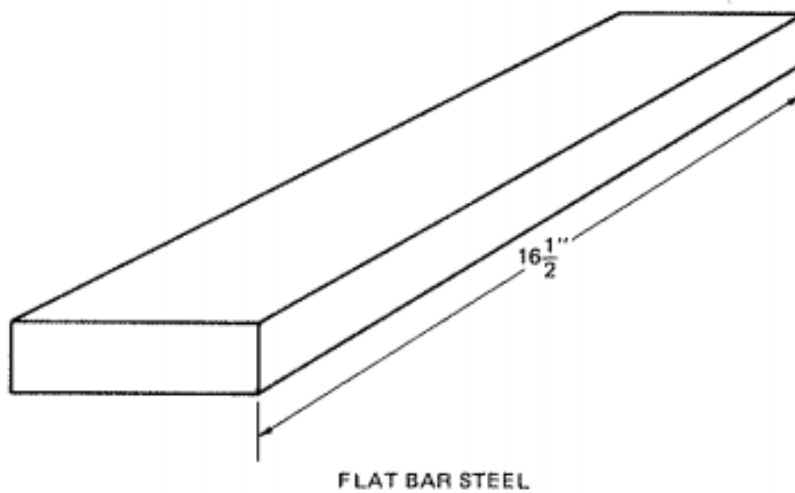

- 10** A $15\frac{5}{16}$ " diameter circle is flame-cut from this steel plate. Find the missing dimension. The width of the kerf is $\frac{1}{16}$ ".

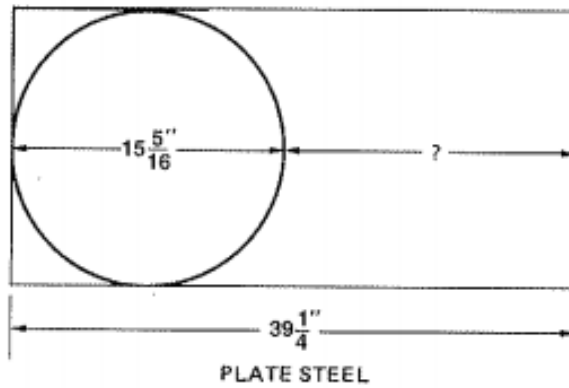

- 11** Find dimension A on this steel angle.

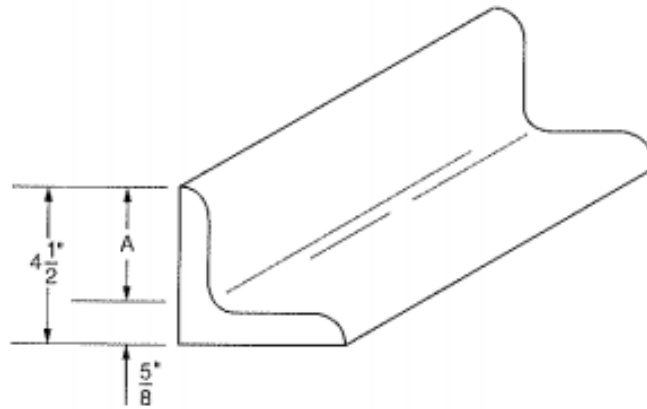

- 12** What is the missing dimension?

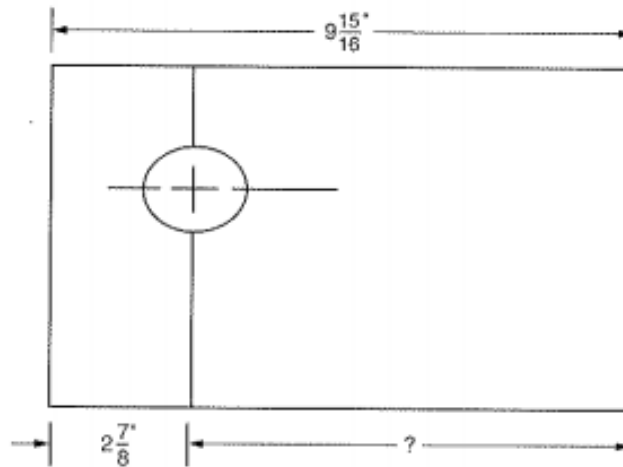

Appendix L

Presentation Problems

PAGE 41: #35

$$3 - \frac{3}{8}$$

PAGE 41: #36

$$8 - 5\frac{3}{4}$$

PAGE 41: #37

$$8\frac{3}{16} - 3\frac{7}{16}$$

PAGE 41: #38

$$5\frac{3}{8} + 2\frac{3}{4}$$

PAGE 41: #39

$$7\frac{3}{16} - 4\frac{7}{8}$$

PAGE 41: #42

$$4\frac{5}{12} + 6\frac{17}{20}$$

PAGE 41: #48

A welder has four pieces of scrap steel angle of lengths $3\frac{1}{4}$ ft, $2\frac{3}{8}$ ft, $3\frac{1}{8}$ ft, and $4\frac{3}{16}$ ft. If they are welded together, how long is the welded piece?

PAGE 41: #49

A welder has two pieces of half-inch pipe, one of length $2\frac{3}{8}$ ft and another of length $3\frac{7}{8}$ ft. What is the total length of the two welded together? If she needs a total length of $4\frac{3}{4}$ ft, how much must be cut off?

PAGE 42: #50

What is the difference in size (diameter) of 6011 welding rods of diameter $\frac{1}{8}$ inch and Super Strength 100 rods of diameter $\frac{3}{32}$ inch?

PAGE 42: #60

Find the missing dimension in the figure below:

60.

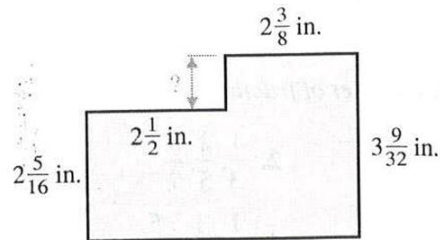

PAGE 42: #61

Find the missing dimension in the figure below:

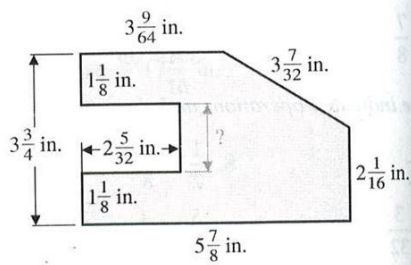

PAGE 42: #62

Find the missing dimension in the figure below:

62.

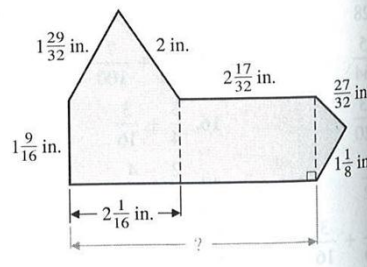

PAGE 42: #63

Find the missing dimension in the figure below:

63.

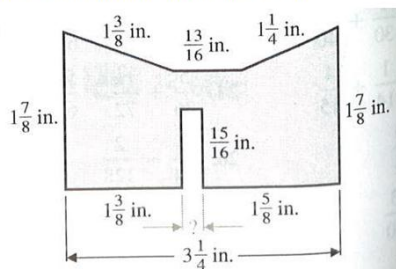

PAGE 43: #64

The perimeter of a triangle is $59\frac{9}{32}$ inches. One side is $19\frac{5}{8}$ inches and a second side is $17\frac{13}{16}$ inches. How long is the remaining side?

Appendix M

Bomb Game Questions

A	What size pieces (what denominator) could be used while solving the following problem? $2\frac{1}{3} + 5\frac{3}{8}$
B	Rename $7\frac{3}{8}$ as an improper fraction.
C	Name a fraction that is a “version of one”.
D	Convert $\frac{35}{32}$ into a mixed number in simplest form.
E	What size pieces (what denominator) could be used while solving the following problem? $7\frac{1}{4} - 2\frac{9}{16}$
F	Convert $\frac{25}{8}$ into a mixed number in simplest form.
G	What size pieces (what denominator) could be used while solving the following problem? $3\frac{3}{8} + 5\frac{1}{8}$
H	Name a “version of one” that would help in simplifying the fraction $\frac{15}{35}$.
I	Solve. $4\frac{1}{8} - \frac{3}{8}$
J	Convert $\frac{44}{8}$ into a mixed number in simplest form.
K	Name a “version of one” that would help in simplifying the fraction $\frac{34}{100}$.
L	Solve. $\frac{1}{3} \times 21$
M	What size pieces (what denominator) could be used while solving the following problem? $9\frac{1}{7} + 4\frac{1}{2}$

N	Solve. $\frac{5}{6} \div 1\frac{2}{3}$
O	Name a "version of one" that would help in simplifying the fraction $\frac{21}{70}$.
P	Solve. $\frac{1}{9} \div 3$
Q	Name a "version of one" that would help in simplifying the fraction $\frac{22}{55}$.
R	Convert $\frac{21}{8}$ into a mixed number in simplest form.
S	Solve. $3 \div \frac{1}{9}$
T	What size pieces (what denominator) could be used while solving the following problem? $1\frac{2}{3} - \frac{1}{9}$
U	Do you need to use "Plan B" in order to solve the following division problem? Yes or no? $\frac{1}{2} \div \frac{1}{4}$
V	Rename $9\frac{3}{8}$ as an improper fraction.
W	Convert $\frac{21}{16}$ into a mixed number in simplest form.
X	Do you need to use "Plan B" in order to solve the following division problem? Yes or no? $4\frac{1}{2} \div 3$
Y	Name a "version of one" that would help in simplifying the fraction $\frac{14}{35}$.
Z	Rename $1\frac{3}{16}$ as an improper fraction.

Appendix N

Unit Exam

I'm _____ and my favorite fraction equivalent to $\frac{3}{4}$ is _____!
(1 point)

1. Complete the table below by listing three equivalent fractions for each fraction shown. (9 points)

FRACTION	THREE EQUIVALENT FRACTIONS
$\frac{5}{8}$	
$\frac{3}{5}$	
$\frac{9}{15}$	

2. Read the distances from the start of this steel tape measure to the letters (3 points):

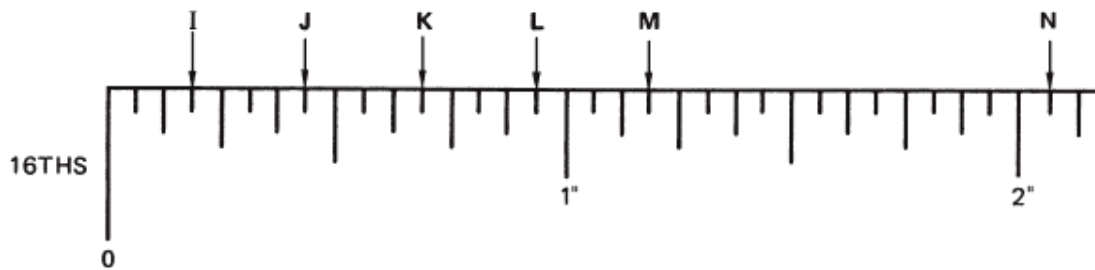

3. How many fourths are in 1 whole? (1 point) How many fourths are in 2 wholes? (1 point) How many fourths are in 17 wholes? (1 point)
4. A student was asked to write three fractions equivalent to $\frac{7}{8}$. Analyze the student's work shown below. Determine which "versions of 1" he used to create each of the equivalent fractions. (3 points)

$$\frac{7}{8} = \frac{21}{24} \qquad \frac{7}{8} = \frac{63}{72} \qquad \frac{7}{8} = \frac{70}{80}$$

5. Simplify the following fractions. For full credit, show the division you used to reduce each fraction. (8 points)

$$\frac{100}{150}$$

$$\frac{58}{62}$$

$$\frac{99}{108}$$

$$\frac{24}{84}$$

6. Rewrite each fraction below as a mixed number in simplest form. (8 points)

$$\frac{78}{5}$$

$$\frac{28}{3}$$

$$\frac{45}{36}$$

$$\frac{84}{9}$$

7. Complete the table below. (8 points)

MIXED NUMBER	IMPROPER FRACTION
$3\frac{5}{6}$	
$10\frac{3}{5}$	
$6\frac{7}{8}$	
$8\frac{1}{5}$	

8. Find the length of the missing dimensions in each of the following figures. Then, find the perimeter of each figure. Remember to label your answers with appropriate units of measurement. (10 points)

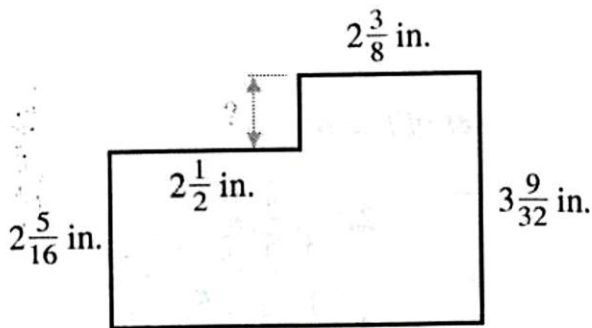

? = _____

perimeter = _____

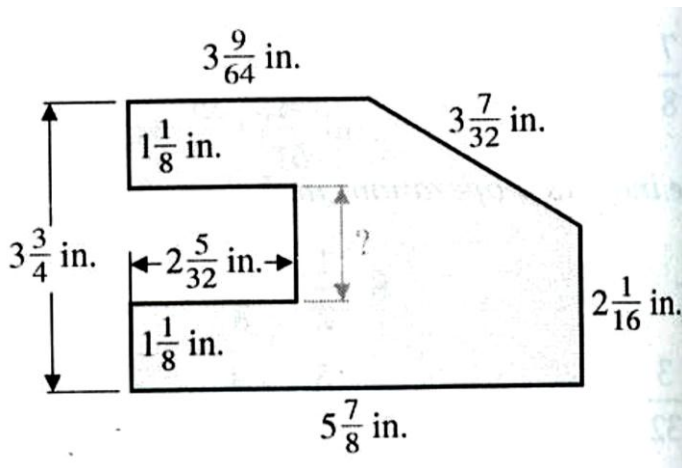

? = _____

perimeter = _____

9. A welder uses seven 6011 welding rods to weld two metal slabs. If each rod makes a $6\frac{1}{2}$ inch weld, find the total length of the weld. Please label your answer appropriately. (2 points)

10. A welder has $6\frac{3}{5}$ feet of $\frac{1}{2}$ inch pipe. How many pieces of pipe, each of length $1\frac{3}{4}$ feet, can be obtained from the original pipe? (2 points)

11. Find the total combined weight of these three pieces of steel (2 points, please label your answer appropriately):

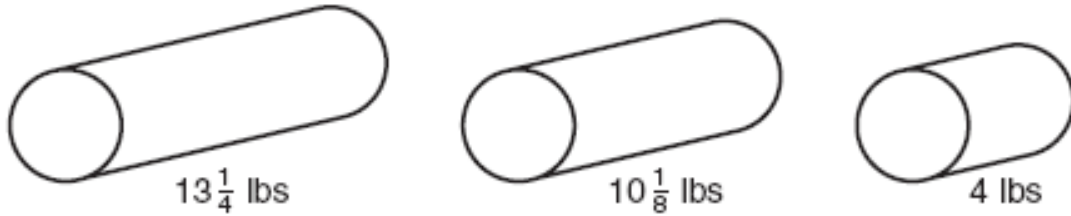

12. Each bar of angle iron weighs $17\frac{3}{4}$ pounds. If 284 pounds of angle iron are in the stock pile, how many bars are in stock? (2 points)

13. Determine the missing dimension (2 points, please label your answer appropriately):

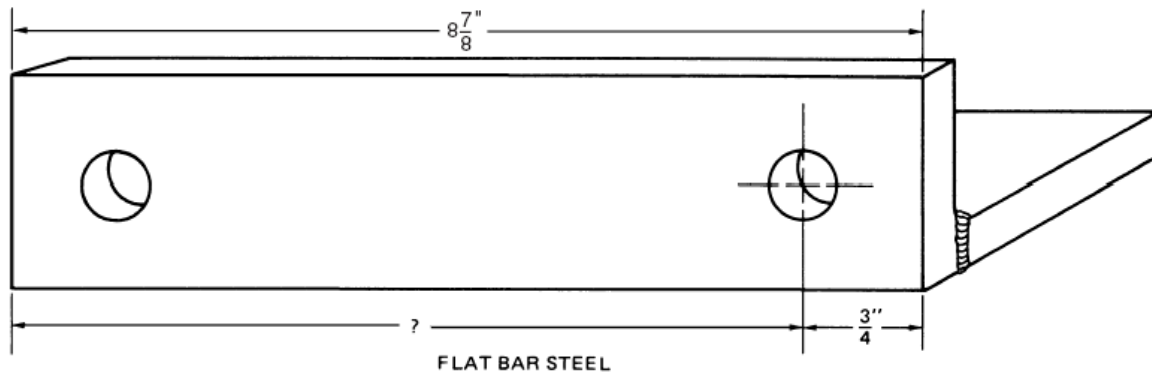

14. Five steel bars, each $6\frac{1}{2}$ " long, are welded together; how long will the new bar be? Please label your answer appropriately. (2 points)

15. Divide a $38\frac{1}{8}$ " piece of mild steel into 6 equal parts. What is the length of 3 parts when welded together? (2 points)

16. A 36" piece of steel angle is in stock. How many $5\frac{1}{2}$ " pieces may be cut from it? (2 points)

17. A pipeline is laid at the rate of $\frac{1}{8}$ mile per day. How many miles of line would be completed in $29\frac{1}{2}$ days? (2 points)

18. Clearly explain the mistakes made in the problems below. (6 points)

$$5\frac{1}{2} \div \frac{1}{6}$$

$$\frac{5}{9} \times 3\frac{1}{10}$$

$$3\frac{1}{9} - 2\frac{2}{3}$$

$$\frac{11}{2} \div \frac{1}{6}$$

$$\frac{5}{9} \times \frac{31}{10}$$

$$3\frac{1}{9} - 2\frac{6}{9}$$

$$\frac{2}{11} \times \frac{1}{6}$$

$$\frac{155}{90}$$

$$1\frac{5}{9}$$

$\frac{2}{666}$ → Simplified
 $\frac{1}{333}$

19. Calculate dimensions for (A), (B), (C), and (D). (12 points)

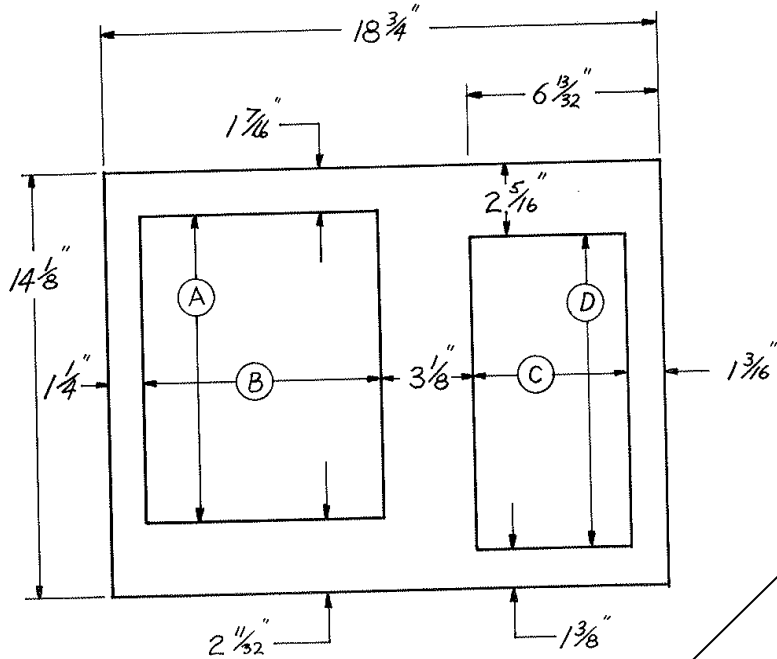

EXTRA CREDIT

85 frames (sample shown to the right) are to be fabricated. What is the total number of inches of tubing required?

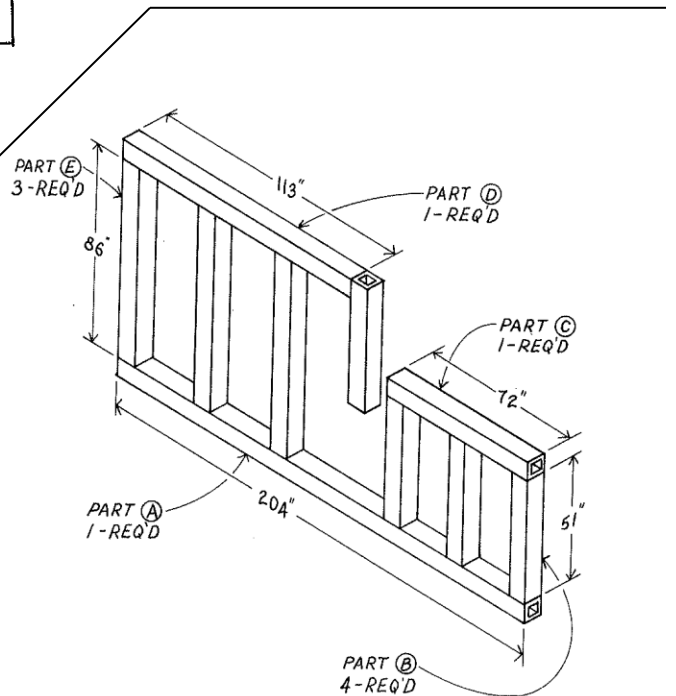

A SAMPLE OF POST-TEST RESPONSES TO ITEM 1

Read the distances from the start of this steel tape measure to the letters (3 points):

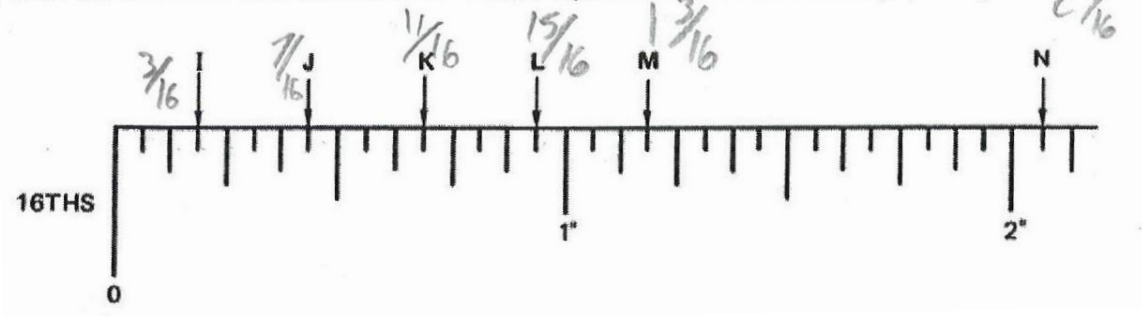

Read the distances from the start of this steel tape measure to the letters (3 points):

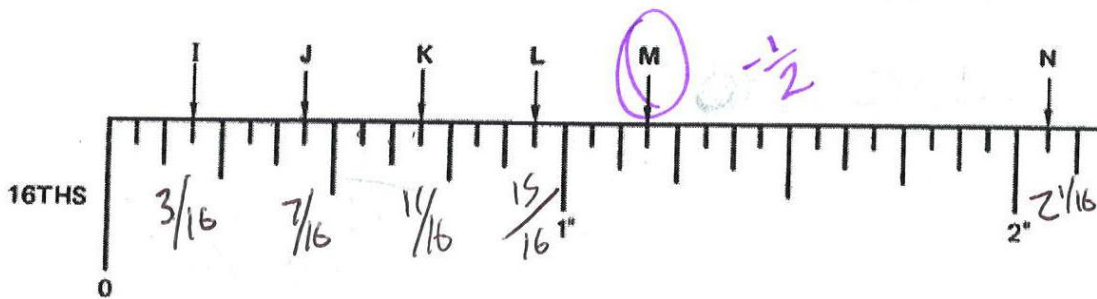

Read the distances from the start of this steel tape measure to the letters (3 points):

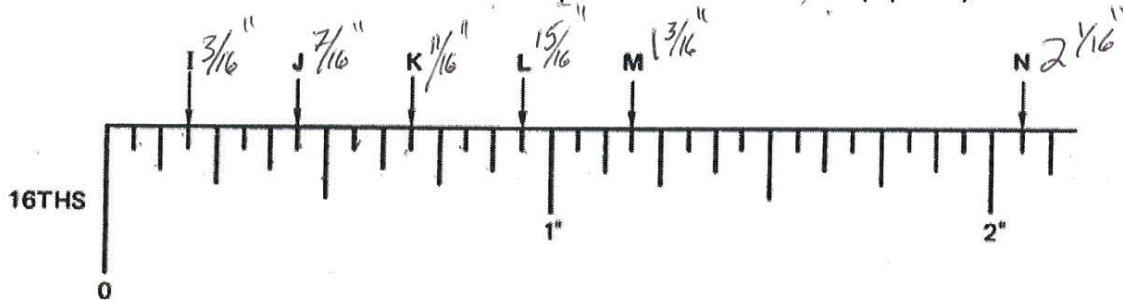

Read the distances from the start of this steel tape measure to the letters (3 points):

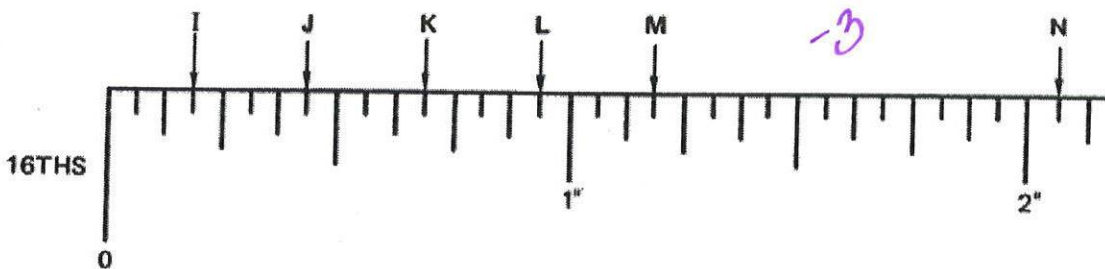

A SAMPLE OF POST-TEST RESPONSES TO ITEM 2

How many fourths are in 1 whole? (1 point) 4

How many fourths are in 2 wholes? (1 point) 8

How many fourths are in 17 wholes? (1 point) 68

How many fourths are in 1 whole? (1 point) $\frac{1}{4}$

How many fourths are in 2 wholes? (1 point) $\frac{2}{4}$

How many fourths are in 17 wholes? (1 point) $\frac{68}{4}$

How many fourths are in 1 whole? (1 point) 4 4ths

How many fourths are in 2 wholes? (1 point) 8 4ths

How many fourths are in 17 wholes? (1 point) 68 4ths

A SAMPLE OF POST-TEST RESPONSES TO ITEM 3

combined weight of these three pieces of steel (2 points, please label your answer appropriately):

$13\frac{1}{8}$ lbs $10\frac{1}{8}$ lbs 4 lbs
 $27\frac{3}{8}$ lbs

the total combined weight of these three pieces of steel (2 points, please label your answer appropriately):

$13\frac{1}{4}$ lbs $10\frac{1}{8}$ lbs 4 lbs
 $\frac{2}{8} + \frac{1}{8} = \frac{3}{8}$
 $27\frac{3}{8}$ lbs

total combined weight of these three pieces of steel (2 points, please label your answer appropriately):

$13\frac{1}{4}$ lbs $10\frac{1}{8}$ lbs 4 lbs
 $13\frac{2}{4} + 10\frac{1}{8} + 4$
 $28\frac{3}{8}$ lbs

A SAMPLE OF POST-TEST RESPONSES TO ITEM 4

Determine the missing dimension (2 points, please label your answer appropriately):

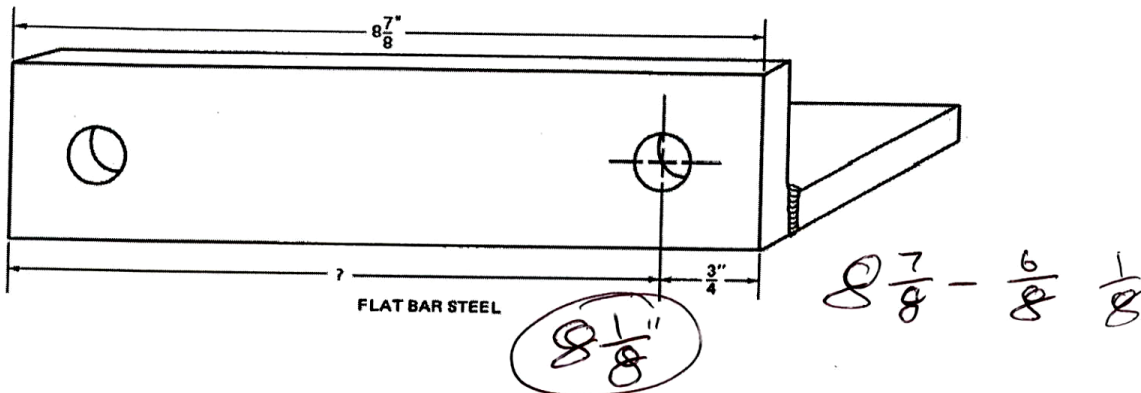

Determine the missing dimension (2 points, please label your answer appropriately):

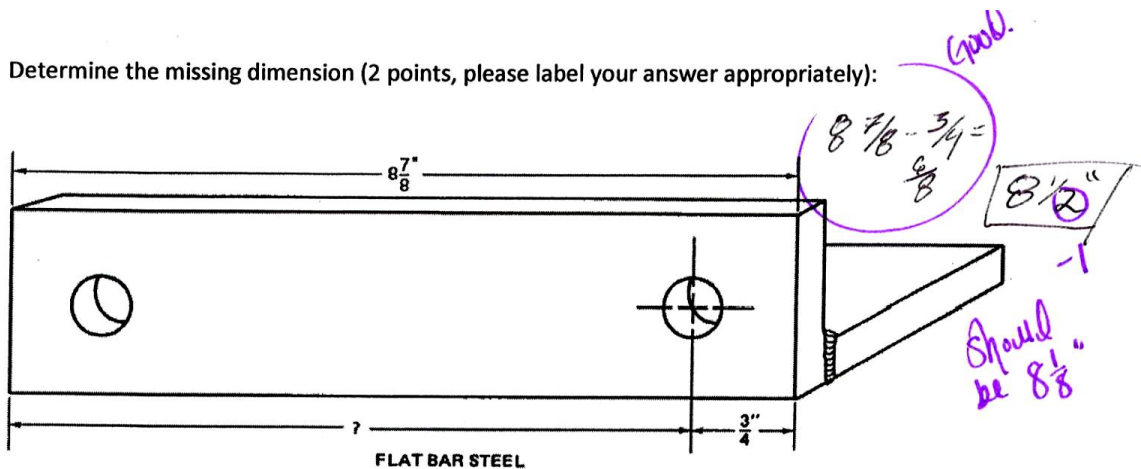

Determine the missing dimension (2 points, please label your answer appropriately):

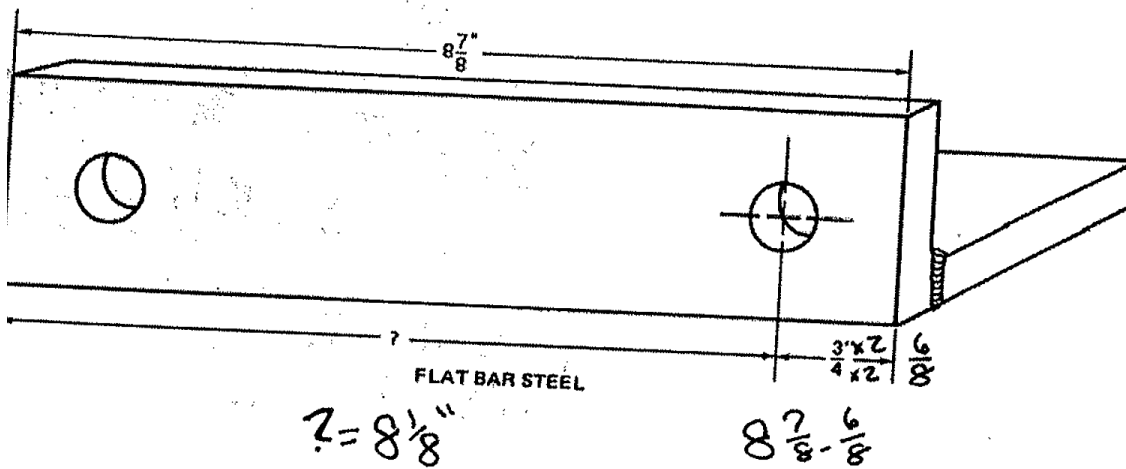

A SAMPLE OF POST-TEST RESPONSES TO ITEM 5

Five steel bars, each $6\frac{1}{2}$ " long, are welded together; how long will the new bar be? Please label your answer appropriately. (2 points)

$$6\frac{1}{2} \times 5 = 32\frac{1}{2}"$$

Five steel bars, each $6\frac{1}{2}$ " long, are welded together; how long will the new bar be? Please label your answer appropriately. (2 points)

$$6 \times 5 = 30$$

$$\frac{1}{2} \times 5 = 2\frac{1}{2}$$

$$\boxed{32\frac{1}{2}"}$$

Five steel bars, each $6\frac{1}{2}$ " long, are welded together; how long will the new bar be? Please label your answer appropriately. (2 points)

$$6\frac{1}{2} \times 5 = \frac{13}{2} \times \frac{5}{1} = \frac{65}{2} = \boxed{32\frac{1}{2} \text{ in long}}$$

Five steel bars, each $6\frac{1}{2}$ " long, are welded together; how long will the new bar be? Please label your answer appropriately. (2 points)

$$5 \times 6\frac{1}{2} = \boxed{32.5}"$$

A SAMPLE OF POST-TEST RESPONSES TO ITEM 6

15. Divide a $38\frac{1}{8}$ " piece of mild steel into 6 equal parts. What is the length of 3 parts when welded together?

(2 points)

$$38\frac{1}{8} \div 6 = 6\frac{5}{8}$$

$$37\frac{9}{8}$$

$$\frac{354}{1} \times \frac{32}{16} = \frac{32}{32}$$

-1

Divide a $38\frac{1}{8}$ " piece of mild steel into 6 equal parts. What is the length of 3 parts when welded together?

(2 points)

$$\frac{1}{8} = .125$$

$$38.125 \div 6 = 6.35" = \boxed{19.05}"$$

-1

close!

Divide a $38\frac{1}{8}$ " piece of mild steel into 6 equal parts. What is the length of 3 parts when welded together?

(2 points)

$$38\frac{1}{8} = \frac{305}{8}$$

$$\frac{305}{8} \times \frac{1}{6} = \frac{305}{48} = 6\frac{17}{48} \times 3$$

$$\frac{305}{48} \times \frac{3}{1} = \frac{915}{48} = 19\frac{3}{48}$$

$$= \boxed{19\frac{1}{16} \text{ in}}$$

Divide a $38\frac{1}{8}$ " piece of mild steel into 6 equal parts. What is the length of 3 parts when welded together?

(2 points)

$$\frac{305}{8} \cdot \frac{1}{6} = \frac{305}{48} = 6\frac{17}{48} \times 3$$

$$\frac{17}{48} \times \frac{3}{1} = \frac{51}{48} = \frac{3}{48} = \frac{1}{16}$$

$$6 \times 3 = 18$$

$$\boxed{19\frac{1}{16}"}$$