



**Investigation of  
Vertical Members  
to Resist Surficial  
Slope Instabilities**

SPR # 0092-05-09

---

**Hani Titi and Sam Helwany  
Department of Civil Engineering and Mechanics  
University of Wisconsin-Milwaukee**

June 2007

WHRP 07-03

Wisconsin Highway Research Program Project ID 0092-05-09

**Investigation of Vertical Members to Resist Surficial Slope Instabilities**

Final Report

Hani H. Titi, Ph.D., P.E.

Associate Professor

and

Sam Helwany, Ph.D., P.E.

Associate Professor

Department of Civil Engineering and Mechanics

University of Wisconsin – Milwaukee

3200 N. Cramer St.

Milwaukee, WI 53211

Submitted to

**The Wisconsin Department of Transportation**

June 2007

1. Report No.	2. Government Accession No	3. Recipient's Catalog No	
4. Title and Subtitle <b>Investigation of Vertical Members to Resist Surficial Slope Instabilities</b>		5. Report Date <b>June 2007</b>	6. Performing Organization Code
7. Authors <b>Hani H. Titi and Sam Helwany</b>		Performing Organization Report No.	
8. Performing Organization Name and Address <b>University of Wisconsin-Milwaukee Office of Research Services and Administration Mitchell Hall, Room 273Milwaukee, WI 53201</b>		10. Work Unit No. (TRAIS)	11. Contract or Grant No. <b>WHRP 0092-05-09</b>
12. Sponsoring Agency Name and Address <b>Wisconsin Department of Transportation Division of Transportation Infrastructure Development Research Coordination Section 4802 Sheboygan Avenue Madison, WI 53707</b>		13. Type of Report and Period Covered	14. Sponsoring Agency Code
15. Supplementary Notes			
16. Abstract			
<p>This report summarizes the state of the art of using reinforcing structural members to stabilize surficial slope failures. The literature search and review conducted in this study indicated that the use of structural members for stabilizing surficial slope failures is not common practice; however, there is great interest in this methodology. The research team identified the following three innovative methods of surficial slope stability: installing small size structural members by conventional methods; installing launched soil nails, and installing earth anchors. This report includes detailed information regarding the design and analysis methodology for structural members, the material properties of structural members used, construction methods, cost-effectiveness, and case histories. It should be noted that there is little documented information available on this subject.</p> <p>In order to investigate the influence of installing structural members to stabilize surficial slope instabilities in Wisconsin, a comprehensive slope stability analysis was conducted using Wisconsin soil and slope input parameters and various soil strength parameters under dry and saturated conditions. The analysis conducted in this report and by other studies demonstrates the effectiveness of using the structural members in stabilizing surficial slope failures.</p> <p>Based on the information and data available, the methods that have potential merit to stabilize surficial slope failures in Wisconsin in terms of cost-effectiveness and field performance are the small size conventional structural members and the earth anchoring systems. Short-term field performance data demonstrated that plastic lumber is an effective remediation method if installed in closely spaced configuration. Wood lumber and earth anchors also are considered cost-effective. Long-term field performance data on the use of these materials is not available to draw any rational conclusions. Creep of plastic lumber and decay of wood lumber in aggressive environments may impact the behavior of these structural elements in the future and therefore the stability of the slopes they are used to repair.</p>			
17. Key Words		18. Distribution Statement No restriction. This document is available to the public through the National Technical Information Service 5285 Port Royal Road Springfield, VA 22161	
19. Security Classif.(of this report) Unclassified	19. Security Classif. (of this page) Unclassified	20. No. of Pages 84	21. Price

## **Disclaimer**

This research was funded through the Wisconsin Highway Research Program by the Wisconsin Department of Transportation and the Federal Highway Administration under Project # 0092-05-09. The contents of this report reflect the views of the authors who are responsible for the facts and the accuracy of the data presented herein. The contents do not necessarily reflect the official views of the Wisconsin Department of Transportation or the Federal Highway Administration at the time of publication.

This document is disseminated under the sponsorship of the Department of Transportation in the interest of information exchange. The United States Government assumes no liability for its contents or use thereof. This report does not constitute a standard, specification, or regulation.

The United States Government does not endorse products or manufacturers. Trade and manufacturers' names appear in this report only because they are considered essential to the object of the document.

## Abstract

This report summarizes the state of the art of using reinforcing structural members to stabilize surficial slope failures. The literature search and review conducted in this study indicated that the use of structural members for stabilizing surficial slope failures is not common practice; however, there is great interest in this methodology. The research team identified the following three innovative methods of surficial slope stability: installing small size structural members by conventional methods; installing launched soil nails, and installing earth anchors. This report includes detailed information regarding the design and analysis methodology for structural members, the material properties of structural members used, construction methods, cost-effectiveness, and case histories. It should be noted that there is little documented information available on this subject.

In order to investigate the influence of installing structural members to stabilize surficial slope instabilities in Wisconsin, a comprehensive slope stability analysis was conducted using Wisconsin soil and slope input parameters and various soil strength parameters under dry and saturated conditions. The analysis conducted in this report and by other studies demonstrates the effectiveness of using the structural members in stabilizing surficial slope failures.

Based on the information and data available, the methods that have potential merit to stabilize surficial slope failures in Wisconsin in terms of cost-effectiveness and field performance are the small size conventional structural members and the earth anchoring systems. Short-term field performance data demonstrated that plastic lumber is an effective remediation method if installed in closely spaced configuration. Wood lumber and earth anchors also are considered cost-effective. Long-term field performance data on the use of these materials is not available to draw any rational conclusions. Creep of plastic lumber and decay of wood lumber in aggressive environments may impact the behavior of these structural elements in the future and therefore the stability of the slopes they are used to repair.

## **Acknowledgement**

This research project is financially supported by the Wisconsin Department of Transportation (WisDOT) through the Wisconsin Highway Research Program (WHRP).

The authors would like to acknowledge the WisDOT Project Research Committee: Jeffrey Horsfall, Andrew Zimmer, and Gustave Hanold for their guidance and valuable input in this research project. The authors also would like to thank Robert Arndorfer, WHRP Geotechnical TOC Chair for his support.

The research team would like to thank many people at UW-Milwaukee who helped in the accomplishment of the research project, namely graduate students Mohammed Elias and Aaron Coenen.

The authors would like to thank Ms. Michelle Schoenecker and Dr. Marjorie Piechowski, for their valuable comments on the final report.

# Table of Contents

<b>Abstract</b> .....	iv
<b>Acknowledgement</b> .....	v
<b>List of Tables</b> .....	ix
<b>List of Figures</b> .....	xi
<b>Executive Summary</b> .....	xv
<b>Chapter 1: Introduction</b> .....	1
1.1 Problem Statement.....	1
1.2 Research Objectives.....	1
1.3 Research Report.....	2
<b>Chapter 2: Background</b> .....	3
2.1 Slope Failures.....	3
2.2 Shallow Slope Failures.....	5
2.3 Mechanism of Shallow Slope Failures.....	7
2.4 Stability Analysis of Shallow Slopes - Engineering Practice.....	10
2.5 Methods of Repair for Shallow Slope Failures.....	12
2.5.1 Rebuilding Failure Zones.....	12
2.5.2 Pipe Pile and Wood Lagging.....	12
2.5.3 Geogrid Repair.....	13
2.5.4 Soil Cement Repair.....	13
2.5.5 Repair Using Conventional Structural Members.....	15
2.5.6 Repair Using Launched Soil Nails.....	16

2.5.7 Repair Using Earth Anchors.....	19
2.6 Slopes and Surficial Slope Failures in Wisconsin.....	22
2.6.1 Slope Design.....	22
2.6.2 Surficial Slope Failures and Repair.....	24
<b>Chapter 3: Stabilization of Shallow Slope Failures Using Short Structural Members..</b>	<b>31</b>
3.1 Introduction.....	31
3.2 Design and Analysis Methodology.....	32
3.2.1 Stability Analysis of Slopes.....	32
3.2.2 Stability of Slopes Reinforced With Structural Members.....	34
3.2.3 Development of Limit Lateral Resistance Curves.....	35
3.2.4 Parametric Evaluation of the Design and Analysis Method.....	43
3.3 Materials.....	49
3.3.1 Recycled Plastic Members.....	49
3.3.2 Wood Lumber.....	53
3.3.3 Steel.....	54
3.4 Construction.....	55
3.5 Case Histories.....	59
3.6 Cost Analysis.....	64
3.6.1 Conventional Structural Members.....	64
3.6.2 Launched Soil Nails.....	67
3.6.3 Earth Anchoring Systems.....	67
3.7 Slope Stability Analysis Using Wisconsin Input Parameters.....	68

<b>Chapter 4: Conclusions and Recommendations</b> .....	81
<b>References</b> .....	83

## List of Tables

Table 2.1: Average precipitation in Wisconsin .....	10
Table 3.1: Computed factors of safety for slopes reinforced with 4-in. members placed perpendicular to the face of the slope (after Liew, 2000).....	44
Table 3.2: Computed factors of safety for slopes reinforced with 4-in. members placed vertically (after Liew, 2000).....	44
Table 3.3: Computed factors of safety for slopes reinforced with 4-in. members placed perpendicular to slope (after Liew, 2000).....	45
Table 3.4: ASTM standard test methods used by the plastics industry to evaluate the material properties of plastic lumber.....	50
Table 3.5: Plastic lumber properties from standard laboratory tests (Resco Plastics, Inc., 2007).....	51
Table 3.6: Average values of standard test results on Select™ Lumber provided by Bedford Technology®.....	52
Table 3.7: Material property test results on recycled plastic subjected to various environmental conditions (after Loehr et al. 2000).....	52
Table 3.8: Engineering properties of wood lumber (American Forest & Paper Association, 2007).....	53
Table 3.9: Engineering properties of treated wood lumber (US Army Corps of Engineers, Civil Engineering Laboratory).....	53
Table 3.10: Engineering properties of SAE 1008 Steel .....	54
Table 3.11: Mechanical properties for cold formed tubing (ASTM A500 steel).....	54
Table 3.12: Comparison of different equipment performance used to install structural members to stabilize shallow slope failures in Missouri.....	56
Table 3.13: Factor of safety from slope stability analysis using 4 in. square plastic lumber.....	60
Table 3.14: Estimated factors of safety for Sections A through D in slide area S3 and slide areas S1 and S2 at the I-70 Emma test site (after Loehr and Bowders, 2007).....	62
Table 3.15: Cost estimate of various plastic lumber members .....	64
Table 3.16: Cost estimate of small scale treated wood lumber.....	65
Table 3.17: Cost estimate of treated wood lumber used for piles and poles (American Pole and Timber, 2007).....	65
Table 3.18: Cost estimate of various steel pipe piles .....	66
Table 3.19: Cost estimate of construction equipment .....	66

Table 3.20: Summary of factor of safety obtained from the stability analysis of the STH-164 slope with and without reinforcing structural members and a homogenous soil layer of different strength parameters and saturation conditions..... 76

Table 3.21: Summary of factor of safety obtained from the stability analysis of STH-164 slope with and without reinforcing structural members and two soil layers of different strength parameters and saturation conditions..... 80

## List of Figures

Figure 2.1: Types of clay movements (Abramson et al., 2002).....	4
Figure 2.2: Various definitions of factor of safety (Abramson et al., 2002).....	4
Figure 2.3: Pictures of surficial slope failure along STH-164 in Waukesha County, Wisconsin (cut slope).....	5
Figure 2.4: Pictures of surficial slope failure along CTH A near Burlington, Wisconsin (embankment slope).....	5
Figure 2.5: Illustration of typical surficial slope failure (Day, 1997).....	6
Figure 2.6: Aspect ratio of failure mass (Abramson et al., 2002).....	6
Figure 2.7: The effects of rainfall on slopes (Brand, 1985) .....	8
Figure 2.8: Schematic of localized mounding in the failure area with a transient, perched water table in the soil overlying the lower permeability old landslide deposit (Reid et al., 1988).....	8
Figure 2.9: Shallow slope failure at CTH A near Burlington (a) thin layer of clay underlying cohesionless soil; (b) water perched on clay layer seeping through the soil .....	10
Figure 2.10: Pipe pile and wood lagging repair (Day, 1997).....	13
Figure 2.11: Preparation of soil specimen for repeated load triaxial test Repair of surficial slope failure by geogrid (Day, 1997).....	14
Figure 2.12: Soil cement repair of shallow slope failures (Day, 1997).....	14
Figure 2.13: Potential schemes for slope stabilization using structural members: (a) soil nailing, (b) reticulated buttress, and (c) soil doweling (after Loehr et al., 2000).....	15
Figure 2.14: Profile of recycled plastic pins stabilizing a potential sliding surface (Loehr et al., 2000).....	16
Figure 2.15: Installation of recycled plastic pins to stabilize surficial failures (after Loehr et al., 2000).....	16
Figure 2.16: Soil nail launcher used to repair slope failures.....	17
Figure 2.17: Launched soil nails of 1.5 in. diameter and 20 ft. in length .....	17
Figure 2.18: Highway 363 slope south of Moose Jaw, Saskatchewan, was stabilized with launched soil nails .....	17
Figure 2.19: Horizontally launched hollow perforated nails act as drains .....	18

Figure 2.20: Application for soil nails in slope stabilization (FHWA, 2003).....	18
Figure 2.21: Platipus® anchors designed for shallow slope stabilization.....	19
Figure 2.22: Surficial slope failure stabilization by earth anchoring systems (after Platipus®, 2007).....	20
Figure 2.23: Installation of earth anchor .....	21
Figure 2.24: Slope failure and repair along the Highway 26 cut slope in Calaveras County, CA.....	21
Figure 2.25: Wisconsin DOT regions .....	23
Figure 2.26: Shallow slope failure of the reconstructed STH 164 at Sta. 299+00.....	26
Figure 2.27: Pictures of the repaired shallow slope failure at STH-164.....	27
Figure 2.28: Shallow slope failure at STH-16 with water seeping out of the slope face ....	28
Figure 2.29: Riprap repair of shallow slope failure at STH-16.....	28
Figure 2.30: Live staking application at County Trunk Highway K .....	30
Figure 3.1: Slope with assumed slip surface used for equilibrium analysis in slope stability .....	33
Figure 3.2: Individual slice under equilibrium in an analysis using procedures of slices...	34
Figure 3.3: Reinforcement force ( $F_R$ ) on an individual slice in the methods of slices (after Loehr and Bowders, 2007).....	35
Figure 3.4: Example of distributions of limit resistance for multiple members in a reinforced slope (after Loehr and Bowders, 2007).....	35
Figure 3.5: Typical distributions of limit resistance developed for the three limit states considered (After Loehr et al., 2004).....	36
Figure 3.6: (a) Schematic illustrating Failure Mode 1 and (b) Limit resistance curve for failure mode 1 (Loehr & Bowders, 2007).....	37
Figure 3.7: Schematic illustrating calculation of limit resistance force: (a) limit soil pressure and (b) equivalent lateral resistance force (after Loehr et al. 2007).....	38
Figure 3.8: (a) Schematic illustrating Failure Mode 2 and (b) Limit resistance curve for Failure Mode 2 (Loehr & Bowders, 2007).....	39
Figure 3.9: Graphical illustration for computing limit anchorage resistance: (a) integral of limiting soil pressure and (b) equivalent total resisting force (after Loehr et al., 2004).....	39
Figure 3.10: Composite limit lateral resistance distribution for recycled plastic reinforcing member (After Loehr & Bowders, 2007).....	41
Figure 3.11: Slope reinforced with a single row of reinforcing members spaced equally in the longitudinal (strike) direction (after Liew, 2000).....	42

Figure 3.12: Assumed zone of plastic behavior between adjacent piles in a row (after Ito and Matsui, 1975).....	42
Figure 3.13: Estimated slope geometry and conditions and the observed sliding surface used in the analysis (after Liew, 2000).....	43
Figure 3.14: Critical sliding surfaces for a slope reinforced with 4-in. weak members placed perpendicular to the slope face with longitudinal spacing $s_l=3$ ft .....	46
Figure 3.15: Critical sliding surfaces for a slope reinforced with 4-in. strong members placed perpendicular to the slope face with longitudinal spacing $s_l=3$ ft .....	47
Figure 3.16: Slope geometries and soil and site conditions assumed in the parametric study (after Liew 2000).....	48
Figure 3.17: Three potential modes of failure for reinforcing members in slope stabilization applications (Loehr and Bowders, 2007).....	52
Figure 3.18: Equipment used to install plastic pins, steel pipes, and wooden posts at different sites of surficial slopes failures in Missouri (after Loehr and Bowders, 2007).....	57
Figure 3.19: Performance of installation structural members used in the stability of surficial slope failure (after Loehr and Bowders 2007).....	58
Figure 3.20: Surficial slope failures (S1, S2, S3, and S4) along I-70 embankment near Emma, Missouri (Loehr and Bowders, 2007).....	59
Figure 3.21: Plan view of slide areas S1 and S2 at the I-70 Emma site showing a selected layout of reinforcing members (Loehr and Bowders, 2007).....	60
Figure 3.22: Plan view of selected stabilization schemes for slide area S3 at the I-70 Emma test site (Loehr and Bowders, 2007).....	61
Figure 3.23: Slope section assumed in stability condition B (after Loehr and Bowders, 2007).....	61
Figure 3.24: Measured incremental axial stress in instrumented member IMG in slide area S1 at I-70 Emma site during Phase I (Loehr and Bowders, 2007).....	63
Figure 3.25: Measured bending moments in instrumented member IM-H at I-70 Emma test site during Phase I (Loehr and Bowders, 2007).....	63
Figure 3.26: Approximate extent of failure at I-70 Emma site (Loehr and Bowders, 2007).....	63
Figure 3.27: Geometry of STH-164 highway slope that consists of one soft homogeneous soil layer with different combinations of shear strength parameters.....	69
Figure 3.28: Geometry of STH-164 highway slope that consists of an upper soft soil layer over a stiff soil layer with different combinations of shear strength parameters.....	69
Figure 3.29: Geometry of STH-164 highway slope that consists of one soft homogeneous soil layer stabilized with vertical structural members .....	70
Figure 3.30: Geometry of STH-164 highway slope that consists of an upper soft soil layer over a stiff soil layer stabilized with vertical structural members.....	70
Figure 3.31: Surficial slip surface of the STH-164 slope with dry homogeneous cohesionless soil ( $\phi=20^\circ$ ).....	71
Figure 3.32: Surficial slip surface of the STH-164 slope with saturated homogeneous cohesionless soil ( $\phi=20^\circ$ ).....	72

Figure 3.33: Relatively deep slip surface of the STH-164 slope when analysis is conducted with dry soft homogeneous soil layer ( $c' = 20$ psf and $\phi' = 20^\circ$ )...	73
Figure 3.34: Relatively deep slip surface of the STH-164 slope obtained when analysis is conducted with saturated soft homogeneous soil layer ( $c' = 20$ psf and $\phi' = 20^\circ$ ).....	73
Figure 3.35: Slip surface of STH-164 slope that consists of dry homogenous soil layer ( $\phi' = 20^\circ$ ) reinforced with 8-ft. vertical structural members .....	74
Figure 3.36: Slip surface of STH-164 slope that consists of a saturated homogenous soil layer ( $\phi' = 20^\circ$ ) reinforced with 8-ft. vertical structural members .....	75
Figure 3.37: Slip surface of STH-164 slope that consists of a saturated homogenous soil layer ( $c' = 200$ psf and $\phi' = 20^\circ$ ) reinforced with 8-ft. vertical structural members.....	75
Figure 3.38: Surficial slip surface of the STH-164 slope with upper soft dry soil ( $c' = 20$ psf and $\phi' = 15^\circ$ ) and lower stiff dry soil ( $c' = 200$ psf and $\phi' = 28^\circ$ )....	77
Figure 3.39: Surficial slip surface of the STH-164 slope with upper soft saturated soil ( $c' = 20$ psf and $\phi' = 15^\circ$ ) and lower stiff saturated soil ( $c' = 200$ psf and $\phi' = 28^\circ$ ).....	78
Figure 3.40: Slip surface of STH-164 slope that consists of a dry homogenous soil layer ( $c' = 200$ psf and $\phi' = 15^\circ$ ) reinforced with 8-ft. vertical structural members..	79
Figure 3.41: Slip surface of STH-164 slope that consists of a saturated homogenous soil layer ( $c' = 200$ psf and $\phi' = 15^\circ$ ) reinforced with 8-ft. vertical structural members.....	79

## Executive Summary

This report summarizes the state of the art of using reinforcing structural members to stabilize surficial slope failures. The literature search and review conducted in this study indicated that the use of structural members for stabilizing surficial slope failures is not common practice; however, there is great interest in this methodology. The research team identified the following three innovative methods of surficial slope stability: installing small size structural members by conventional methods; installing launched soil nails, and installing earth anchors. This report includes detailed information regarding the design and analysis methodology for structural members, the material properties of structural members used, construction methods, cost-effectiveness, and case histories. It should be noted that there is little documented information available on this subject.

In order to investigate the influence of installing structural members to stabilize surficial slope instabilities in Wisconsin, a comprehensive slope stability analysis was conducted using Wisconsin soil and slope input parameters and various soil strength parameters under dry and saturated conditions. The analysis conducted in this report and by other studies demonstrates the effectiveness of using the structural members in stabilizing surficial slope failures.

Based on the information and data available, the following conclusions are reached:

1. The methods that have potential merit to stabilize surficial slope failures in Wisconsin in terms of cost-effectiveness and field performance are the small size conventional structural members and the earth anchoring systems.
2. Short-term field performance data demonstrated that plastic lumber is an effective remediation method if installed in closely spaced configuration (3ft. spacing).
3. Wood lumber is a cost-effective choice.
4. Long-term field performance data on the use of these materials is not available to draw any rational conclusions. Creep of plastic lumber and decay of wood lumber in aggressive environments may impact the behavior of these structural elements in the future and therefore the stability of the slopes they were used to repair.
5. The use of earth anchors also is a cost-effective choice.

These conclusions were reached based on the available literature compiled in this study. Definitive conclusions on the use and performance of these methods to stabilize shallow slope failures in Wisconsin can be reached by carrying out field experiments. Two sites of surficial slope failures (cut slope and embankments) can be identified and selected by WisDOT engineers in which different sections can be repaired using different structural members (plastic lumber, wood, steel pipes, and earth anchors). These sites will be subjected to complete field and laboratory testing to determine the soil properties and site conditions. In addition, a field monitoring program can be conducted, including installing inclinometers, performing visual surveys, and collecting climate data (from the nearest weather station) to obtain and analyze field performance data. This experiment will provide WisDOT with all necessary information described in this report (i.e., effectiveness of these methods in terms of construction, cost, and long-term performance) so that a decision can be made regarding the implementation of any of these methods to stabilize surficial slope failures in Wisconsin.

# Chapter 1

## Introduction

### 1.1 Problem Statement

Wisconsin Department of Transportation (WisDOT) projects normally require construction of earthen fills and cuts of natural embankment materials. Guidelines for the final design slopes for these fills and cuts are presented in the WisDOT Facility Design Manual (FDM). Field observations showed that slopes at some sites exhibited localized instabilities in the form of surficial (2-4 ft.) failures. These instabilities typically are encountered in fine-grained soils and addressed by Project Development or Operations personnel. The repair methods associated with these problems generally include replacing the failed material to the original slope limits or removing disturbed material, and lining the scarp with geotextile fabric and placing clean granular materials in the area of the scarp. Limited success has been achieved with the first method and moderate success usually occurs with the second method.

Recent methods for repairing shallow slope failures include the use of driven or bored short vertical structural members. This technology has been successfully used in other states such as Missouri. In this methodology, the failed soil is pushed back in place and the structural members are installed vertically into the ground. These members will resist the forces driving the slope failure. Varieties of materials are used to make these structural members, including wood, metal, recycled plastic, and other cost-effective materials.

This research project was initiated to provide WisDOT with a state-of-the-art synthesis on the design, construction, and cost-effectiveness of this technology. WisDOT is looking forward to use this technology for repairing shallow slope failures.

### 1.2 Research Objectives

The objectives of this research project are:

1. To perform a comprehensive literature search and review on the methods of using vertical structural members to stabilize shallow slope failures.
2. To provide WisDOT with a state-of-practice synthesis on the design, construction, and effectiveness of methods/technologies that use short structural members to stabilize surficial slope failures.
3. To perform a comprehensive slope stability analysis on surficial slope failures to determine the size, length, and spacing of these members for each material type (wood, recycled plastic, etc.) using a wide range of Wisconsin soil properties.

### **1.3 Research Report**

This report summarizes the research conducted on the use of reinforcing structural members to stabilize surficial slope failures. The research team identified three innovative methods of surficial slope stability: installing small size structural members by conventional methods; installing launched soil nails; and installing earth anchoring systems. This report includes detailed information regarding the design and analysis methodology for structural members, material properties of structural members used, construction methods, cost-effectiveness, and case histories. It should be noted that there is little documented information available on this subject.

This report is organized in four chapters: Chapter One presents the problem statement and objectives of the study. Chapter Two provides background information on surficial slope failures and repair methods. Chapter Three describes the details of using the reinforcing structural members for repair in surficial slope failures in terms of design and analysis methodology, the material properties of structural members, construction methods, cost-effectiveness, and case history of field performance. Finally, Chapter Four presents the conclusions and recommendations of the study.

## Chapter 2

### Background

This chapter presents background information on surficial failures, failure mechanism, and methods of repair. Background information on shallow slope failures in Wisconsin also is presented.

#### 2.1 Slope Failures

Slope failures are a common occurrence in soils. Usually, these failures occur after prolonged rainfall events that lead to the reduction of soil strength or result from changes in slope geometry (steepening slopes). Sometimes, slopes show warning signs of potential failure, but they can also fail without any warning. Terzaghi and Peck (1967) stated that *slides may occur in almost every conceivable manner, slowly, or suddenly, and with or without any apparent provocation.*

Slopes are generally characterized as stable when the shear strength of the soil provides enough resisting force to counter the effect of gravitational forces that are trying to move the soil mass downslope. The stability of the slope, therefore, is governed by the balance between the driving and resisting forces. Changes in these forces may lead to the loss of slope stability and subsequent slope failure. Increases in driving (gravitational) forces can be triggered by changes in slope geometry, seepage pressure, or added surcharge from traffic loads on highway embankments. Reduction in resisting forces results from increased pore water pressure due to saturation conditions as water perches on impermeable underlying soil layers.

Slopes fail when the soil mass between the slope surface and slip surface moves downslope. The type of soil, soil stratification, slope geometry, and presence of water are among other factors that affect the type of soil movement and the depth of the slip surface. Abramson et al. (2002) described typical slides that can occur in soils: (1) translational, (2) plane or wedge surface, (3) circular, (4) noncircular, and (5) a combination of these types. Figure 2.1 shows the typical types of failures in clay.

Designing of stable slopes requires a rational selection and use of a factor of safety, which accounts for the various uncertainties associated with the determination of soil strength, distribution of pore pressures, and soil stratification. When the level of soil investigation is of low quality and the experience of the engineer is limited, it is expected that a higher factor of safety is used (Abramson et al., 2002).

The factor of safety is calculated by comparing the available shear strength along a potential sliding surface with the equilibrium shear stress that is needed to maintain a just-stable slope. The factor of safety is assumed to be constant along the slip surface and can be defined in terms of stresses (total and effective), forces, and moments, as illustrated in Figure 2.2. Selecting a factor of safety for a typical slope design depends on

many factors, including the level and accuracy of soil data, the experience of the design engineer and the contractor, level of construction monitoring, and consequence of slope failure (risk level). Abramson et al. (2002) indicated that for a typical slope design the required factor of safety ranges between 1.25 and 1.50.

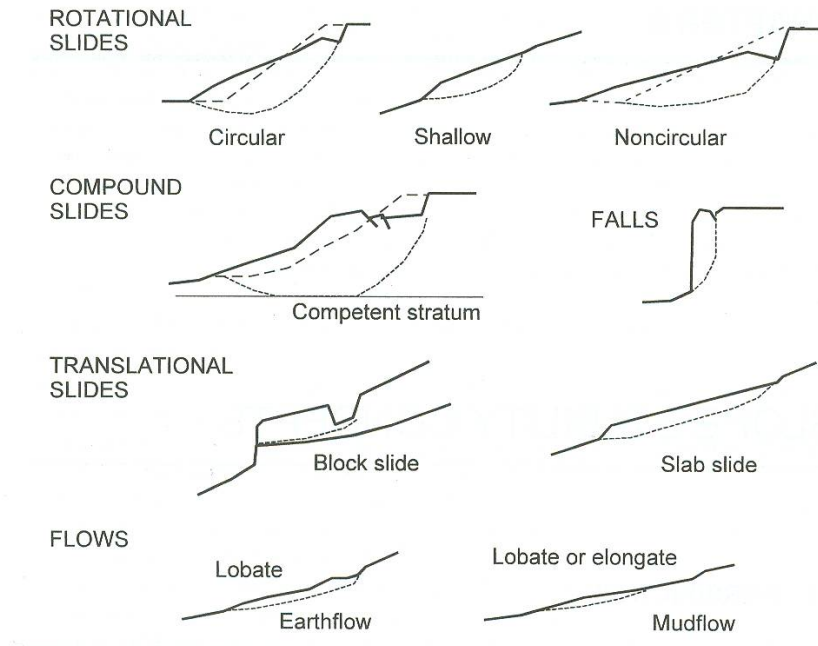

Figure 2.1: Types of clay movements (Abramson et al., 2002).

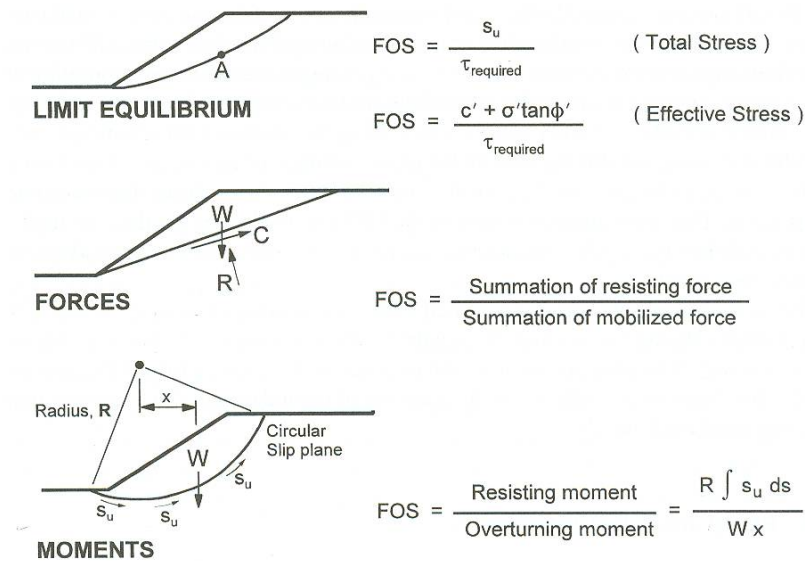

Figure 2.2: Various definitions of factor of safety (Abramson et al., 2002).

## 2.2 Shallow Slope Failures

Shallow slope failure is a term used to describe surficial slope instabilities along highway cut slopes and embankments. These instabilities commonly occur in fine-grained soils, especially after prolonged rainfalls. Wisconsin highway slopes and embankments sometimes experience local instabilities in the form of surficial slope failures. In some cases, these failures occur in newly constructed embankments and slopes (cut sections). Figures 2.3 and 2.4 depict recent surficial failures along the STH-164 cut slope in Waukesha County and on the CTH A embankment near Burlington, respectively. In Wisconsin, shallow slope failures often occur after prolonged and heavy rainfall and sometimes these failures worsen during the spring thaw (snowmelt). Figure 2.5 illustrates a typical surficial slope failure.



Figure 2.3: Pictures of surficial slope failure along STH-164 in Waukesha County, Wisconsin (cut slope).



Figure 2.4: Pictures of surficial slope failure along CTH A near Burlington, Wisconsin (embankment slope).

Shallow slope failures generally do not constitute a hazard on human life or cause major damage. However, shallow slope failures can constitute a hazard to infrastructure by causing damage to guardrails, shoulders, road surface, drainage facilities, utility poles, or

the slope landscaping. In some cases, shallow slope failures can impact regular traffic flow when debris flows onto highway pavements.

Moreover, shallow slope failures can have an economic impact on the highway agencies at the local/district level. Personal communication with different state highway agencies indicated that repairs of shallow slope failures are conducted at the district and local levels and often performed by maintenance crews as routine work. In many cases, such repair will provide a temporary fix of slope failures as the slope failure generally reoccurs after a rainfall season.

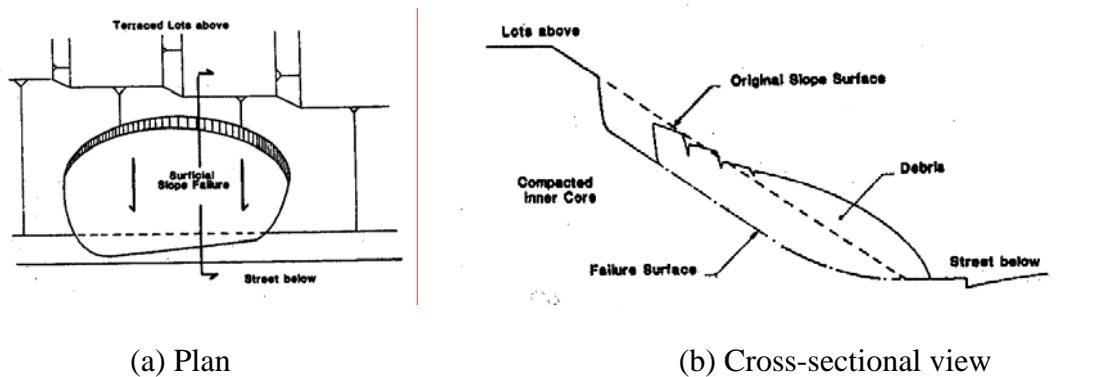

Figure 2.5: Illustration of typical surficial slope failure (Day, 1997).

The aspect ratio of a slide or failure generally is used to classify the slope failure type. As presented in Figure 2.6, a rotational slide produces a failure surface with an aspect ratio of  $0.15 < D/L < 0.33$  where  $D$  is the depth of the sliding surface perpendicular to the slope face and  $L$  is the length of the sliding surface.

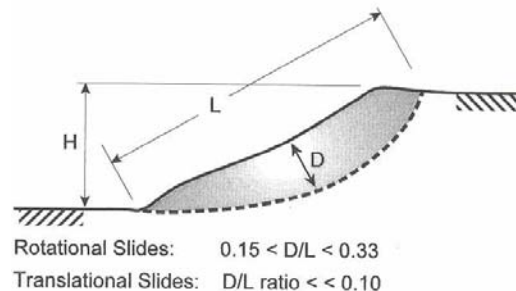

Figure 2.6: Aspect ratio of failure mass (Abramson et al., 2002).

Shallow slope failures vary in depth and extent of the failed area. Slope geometry, soil type, saturation, and seepage are among the factors affecting the size of shallow slope failures. Shallow slope failures often are parallel to the slope surface and usually are considered as infinite slope failures. The depth varies depending on many factors, including soil type, slope geometry, and climatic conditions. Various depths were reported in the literature based on case histories, but all studies indicated a shallow nature

of surficial failures. Evans (1972) defined the failure surface depth of shallow slope to be equal to or less than 4 ft. Loehr et al. (2000) characterized the depth of shallow slope failure as less than 10 ft. Field observations by WisDOT engineers at sites of shallow slope failures indicated that the failure surface depth ranges from approximately 2 to 4 ft. The research team performed field measurements of the depth of a shallow slope failure at STH-164 in Waukesha County (Figure 2.3) and found that the average depth of failure surface is about 2 ft.

The aspect ratio of the failure can be used to categorize whether the slide is shallow or not. In Figure 2.6, when the aspect ratio  $D/L < 15\%$  or failure surface depth  $\leq 10$  ft., the slide is characterized as shallow (Abramson et al. 2002). Hansen (1984) characterized shallow surface slips as those with  $D/L$  ranging from 3 to 6%.

### **2.3 Mechanism of Shallow Slope Failures**

Shallow slope failures often occur during or after periods of heavy rainfall. In the Midwest region, rapid snowmelt resulting from a sudden increase in temperature also can lead to surficial instabilities in slopes and embankments. Many cases of surficial instabilities of slopes are attributed to prolonged-rainfall events, particularly during the spring thaw (snowmelt).

Soil usually is unsaturated above the water table level. During a heavy rainfall, water infiltrates the unsaturated soil. The permeability of the soil is an important factor in this case. During water movement within the soil, the water may encounter a soil with lower permeability, which will act as a drainage barrier. This causes the water to perch on this low permeability soil (or rock) barrier. The unsaturated soil will become saturated, creating localized saturated zones as the water level above the low permeability soil rises quickly (Figure 2.7). When the soil is unsaturated, the pore water pressure is negative (soil suction). The rise in water level leads to a saturated condition in the unsaturated soil and therefore a reduction in soil suction (eventually reduced to zero), and a change in pore water pressure (to positive). This increase in pore water pressure will reduce the effective stress on the potential failure surface, and, consequently, reduce soil strength. When the soil strength decreases beyond the equilibrium values, the slope will fail under increasing pore water pressure and constant total stress (Abramson et al., 2002).

Reid et al. (1988) showed that rainfall leads to positive pore water pressure on slopes that are induced by water perching on low permeability layers, a decreasing slope of the perching layer, groundwater flow convergence controlled by surface or bedrock topography, and spatial variation in soil properties causing localized mounding. Figure 2.8 depicts the water perching on a drainage barrier, causing mounding failure.

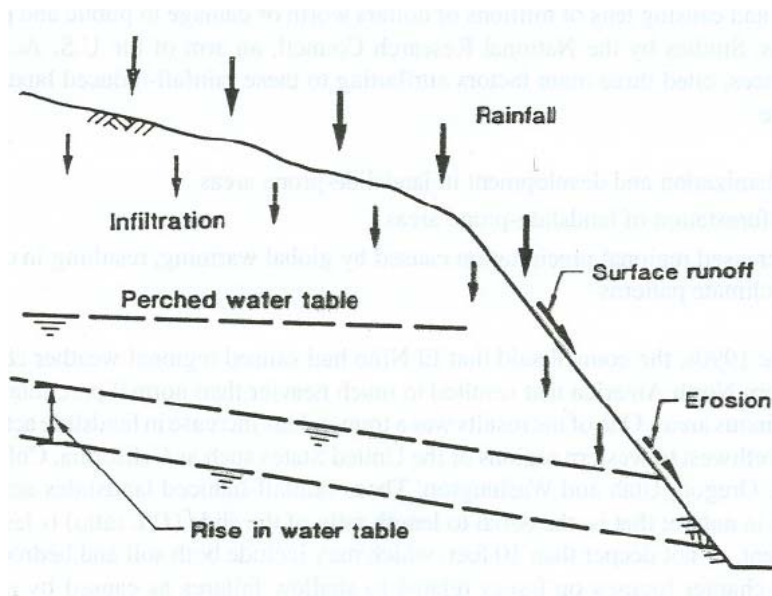

Figure 2.7: The effects of rainfall on slopes (Brand, 1985).

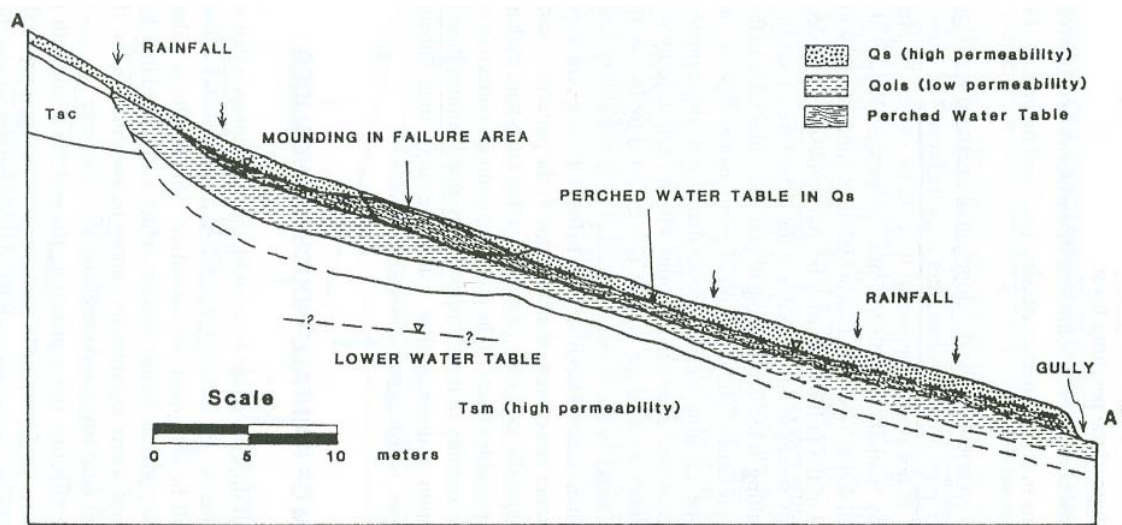

Figure 2.8: Schematic of localized mounding in the failure area with a transient, perched water table in the soil overlying the lower permeability old landslide deposit (Reid et al., 1988).

Landslide occurrence as a result of rainfall is well documented in literature. In southern California, rainfall amounts larger than 140% of the average 100 years (normal amounts) were reported to trigger slope failures (Slosson and Krohn, 1982).

Many shallow slope failures occur when the rainfall intensity is larger than the soil infiltration rate and the rainfall lasts long enough to saturate the slope up to a certain depth, which leads to the buildup of pore water pressure (Abramson et al., 2002). The soil

within a particular slope is assumed to be unsaturated, then it is subjected to continuous wetting by rainfall. The rate at which the slope becomes saturated is crucial to surficial stability and depends on the soil type, whether cohesive or cohesionless. The condition of soil saturation is crucial as it leads to shallow slope failures. When a soil is dry for long period of time, a heavy rainfall event may not lead to saturation; however, when a soil is subjected to moderate levels of rainfall that cause it to become saturated to a depth of 4 ft. while the upper few inches are still unsaturated, a subsequent heavy rainfall can saturate those few upper inches quickly and trigger a slough (Abramson et al., 2002).

Snowmelt, due to rainfall on snow or rapid climate warming, creates a continuous source of water that infiltrates soil for longer time periods. Therefore, snowmelt may result in rising water levels as water perches on drainage barriers, consequently raising pore water pressures that trigger slope failures.

Pradel and Raad (1993) studied the effects of precipitation intensity and permeability on shallow slope failures in southern California. They reported that rainfalls with  $\leq 50$  years returning period cannot lead to saturation conditions to a depth of 4 ft. in soils with permeability  $\geq 3.94 \times 10^{-3}$  in/sec. Based on this conclusion, clayey and silty soils are more susceptible to surficial instabilities in southern California.

The surficial slope failure on the CTH A embankment near Burlington, Wisconsin is believed to have occurred as a result of saturated surficial soil due to prolonged rainfall and snowmelt. The principal investigator and a WisDOT engineer visited the site of the slope approximately two weeks after the failure. They noticed that the surficial soil of the slope was fully saturated with frozen water in some locations. As shown in Figure 2.9a, there is a cohesionless soil layer below the clay blanket, which comprises the top soil cover of the slope. Below the cohesionless soil is a thin clay layer with apparent lower permeability. This layer may act as a drainage barrier, allowing the water to perch on it and rise in the upper surficial soil. When the team excavated a small hole in front of the cohesionless soil layer, water filled the hole very quickly, indicating the abundant presence of water, as shown in Figure 2.9b. When the water rose in the upper surficial soil, the shear strength of the soil was reduced, causing the instability of the surficial soil.

It should be noted that the shallow failure occurred in mid-December, with average precipitation of 1.76 in., in addition to an earlier snowfall of approximately 14 in. in southeast Wisconsin. Wisconsin climate data for the month of December 2006 showed above-average precipitation. It also was considered the 22<sup>nd</sup> wettest December in 111 years of collected data. The above-average precipitation provided a continuous wetting of the slope that was under construction. In addition, the soil of the slope was already wet due to the precipitation from previous months, as shown in Table 2.1. Therefore, this prolonged rainfall led to the saturation of the upper soil and the subsequent surficial failure of the slope. It should be noted the data presented in Table 2.1 are for averages across Wisconsin, not the Burlington area.



(a) Thin clay layer underlying cohesionless soil



(b) Water accumulated in the hole

Figure 2.9: Shallow slope failure at CTH A near Burlington (a) thin layer of clay underlying cohesionless soil; (b) water perched on clay layer seeping through the soil.

Table 2.1: Average precipitation in Wisconsin

Month (2006)	Average precipitation (in)
December	1.76
November	1.74
October	2.34
September	3.19
August	4.27
July	3.48

## 2.4 Stability Analysis of Shallow Slopes – Engineering Practice

Surficial slope failure is treated as infinite slope failure in engineering practice. A brief overview and evaluation of the practice is presented below. In the next chapter, slope stability analysis with respect to the use of structural members is synthesized in the context of the limit equilibrium method/procedures of slices. Details of slope stability analysis using the limit equilibrium method/procedures of slices are available in *Soil Strength and Slope Stability* by Duncan and Wright (2005).

Day (1989) presented a surficial stability analysis of shallow failures according to the requirements of Los Angeles County, Minimum Standards for Slope Stability Analysis (1978). Related aspects of these standards are as follows:

1. Calculations shall be based on analysis procedures for the stability of an infinite slope with seepage parallel to the slope surface or other failure mode, which would yield the minimum factor of safety (*FS*) against failure.
2. Calculations of slopes shall be evaluated using the following equation:

$$FS = \frac{c' + \gamma_b D \cos^2 \alpha \tan \phi'}{\gamma_t D \cos \alpha \sin \alpha} \quad (2.1)$$

where:

$c'$  = effective cohesion

$\phi'$  = effective angle of internal friction

$\alpha$  = slope angle

$D$  = vertical depth of saturated soil

$\gamma_t$  = total unit weight

$\gamma_b$  = buoyant unit weight

3. The minimum acceptable vertical depth of soil saturation shall be 4 ft.
4. The minimum factor of safety for surficial stability shall be 1.50.
5. Shear strength parameters (cohesion and friction angle) determined for use in analyzing the gross stability of the same slope will be considered acceptable for surficial stability analysis without specific justification. The consultant must justify application of higher shear strength values.

Equation 2.1 was proposed by Skempton and Delory (1957) for analyzing the slope stability of infinite slopes with seepage parallel to the face in clay slopes. For cohesionless soils with  $c' = 0$ , Equation 2.1 is reduced to:

$$FS = \left( 1 - \frac{\gamma_w}{\gamma_t} \right) \frac{\tan \phi'}{\tan \alpha} \quad (2.2)$$

Abramson et al. (2002) presented an evaluation of the use of these equations in the analysis of shallow slope stability. They showed that Equation 2.2 will result in sand slopes to be constructed flatter than 3.5:1 (H:V), assuming the angle of internal friction range for sand is between 28 and 40° and  $FS=1.50$ . Equation 2.2 also indicates that slopes steeper than 2.5:1 would be unstable under heavy rain ( $FS=1$ ). Abramson et al. (2002) stated that this is a contradiction to the observations that many 1.5:1 and 2:1 cohesionless soil slopes remained stable after prolonged intense rainfall. In addition, a small increase in cohesion value in Equation 2.1 can increase the factor of safety. Therefore, Equation 2.1 suggests that slopes made of cohesive soils (silt and clay) will have a higher factor of safety and will be less susceptible to surficial instabilities than cohesionless soils (sand and gravel). A study by Hollingsworth and Kovacs (1981) on surficial slope failures after intense rainfall showed that clayey and silty soils are more prone to failure than gravelly and sandy soils.

## **2.5 Methods of Repair for Shallow Slope Failures**

Different repair methods are used to stabilize surficial slope failures. It is often a challenge to implement repair techniques of surficial instabilities due to site access limitations and the difficulties of working on sloped surfaces. Selecting an appropriate repair method depends on the importance of the project (consequence of failure), budget availability, site access, slope steepness, and the availability of construction equipment and experienced contractors. The most commonly used method to repair surficial failures is to rebuild the failed area by pushing the failed soil mass back and re-compact it. Other methods include using geogrid, soil-cement, pipe piles and wood lagging, structural members (plastic lumber, wood, steel pipes), launched soil nails, and soil anchors. Some of these methods are described briefly in this chapter, while slope stability using structural members is described in detail in the following chapter.

### ***2.5.1 Rebuilding Failure Zone***

This method consists of air-drying the failed soil, pushing it back to the failure area, and re-compacting it. It is considered one of the most economical methods of repair and is performed as routine maintenance work on failed slopes. However, this method is not very effective, particularly in clays because it does not significantly increase the shear strength of the re-compacted soil, especially when the soil becomes wet again. In addition, surficial failures damage slope landscaping, which eliminates the root reinforcement of the slope. Once the failed slope is rebuilt, erosion control fabric is installed and seeding is applied to the slope face. It may take a long time before root reinforcement can be established. Reoccurrence of failure often is reported in rebuilt slopes.

### ***2.5.2 Pipe Pile and Wood Lagging***

Day (1997) reported that the use of pipe piles and wood lagging probably is the most frequently used repair method. A typical design is shown in Figure 2.10. The repair method consists of disposing the failed debris off the site and cutting benches into the natural ground below the slip surface. Galvanized steel pipe piles are then installed (driven or placed in pre-drilled holes) and filled with concrete. Wood lagging (pressure treated) is placed behind the piles and a drainage system is then built behind the wood. A selected fill is compacted in layers and the face of the slope is protected with erosion control fabric and landscaping.

One of the disadvantages of this method is that lateral soil pressure against the wood lagging is transferred directly to the pipe piles, which are small in diameter and have low flexural capacity and low resistance to lateral loads. Pile failure in bending is a common occurrence in this repair method. Day (1997) attributed the frequent failure of the repair method to design deficiency in that the piles are not designed; rather, they are selected by contractors based on their experience. Day (1997) provided a design methodology for this repair method.

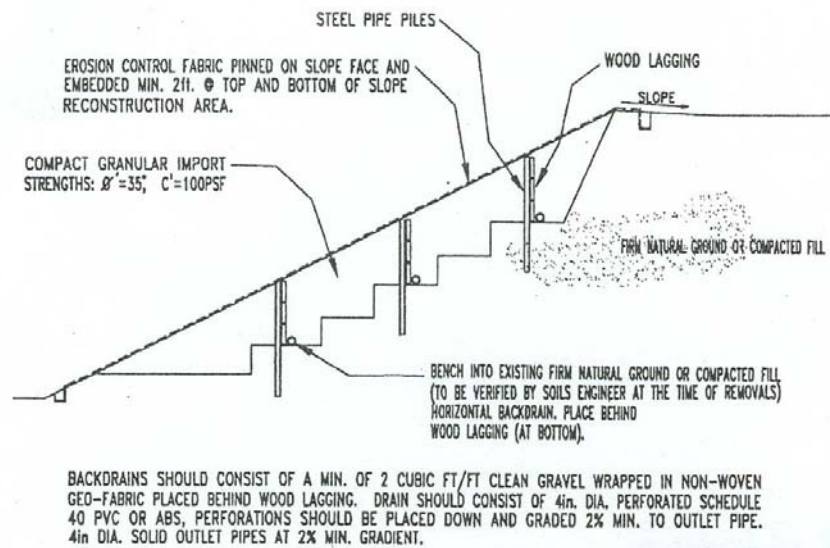

Figure 2.10: Pipe pile and wood lagging repair (Day, 1997).

### 2.5.3 Geogrid Repair

Stabilizing slopes with a geogrid is considered an innovative and cost-effective method. Geogrids are manufactured from high density polyethylene resins. The open structure of geogrids allows for good interlocking with granular materials used to rebuild slope failures.

Repair of surficial slope failures using a geogrid consists of the complete removal of the failed soil mass. Benches are then excavated in the undisturbed soil below the slip surface, as depicted in Figure 2.11. Drains (vertical and horizontal) are installed to collect water from the slope and dispose it off-site. The slope is built by constructing layers of geogrid and compacted granular material. Finally, slope landscaping is completed by installing erosion control fabric and seeding the slope face (Day, 1997).

### 2.5.4 Soil Cement Repair

The repair of surficial slope failures using soil-cement consists of the complete removal of the failed soil mass. Benches are then excavated in the undisturbed soil below the slip surface as depicted in Figure 2.12. Drains (vertical and horizontal) are installed to collect water from the slope and dispose it off-site. Granular fill material usually is mixed with cement (~6%) and the mix is compacted to at least 90% of modified Proctor maximum unit weight (Day, 1997). The soil-cement mix will develop high shear strength and lead to slope stability. Slope landscaping is completed by installing erosion control fabric and seeding the slope face. In cases with flat slopes, it may not be necessary to mix soil with cement.

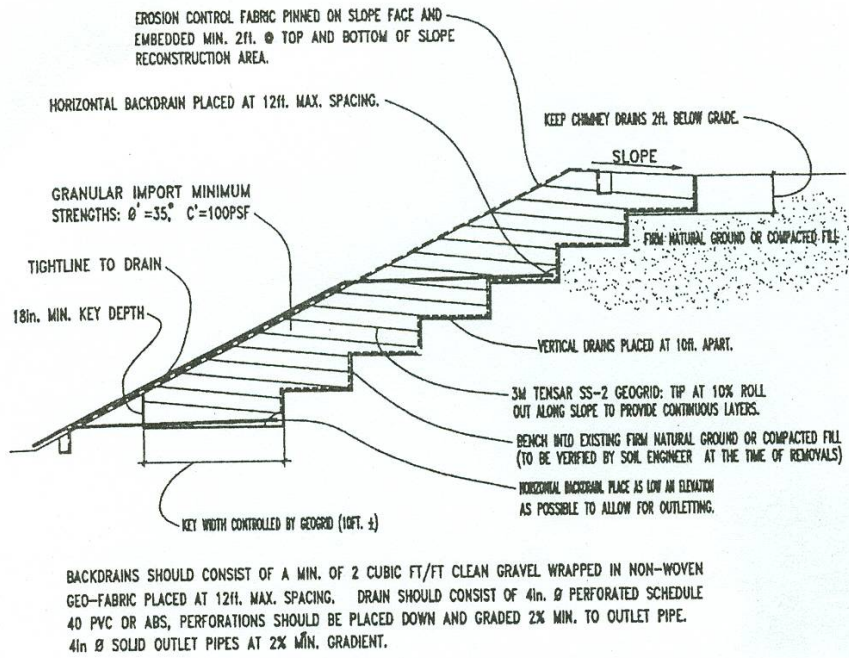

Figure 2.11: Repair of surficial slope failure by geogrid (Day, 1997).

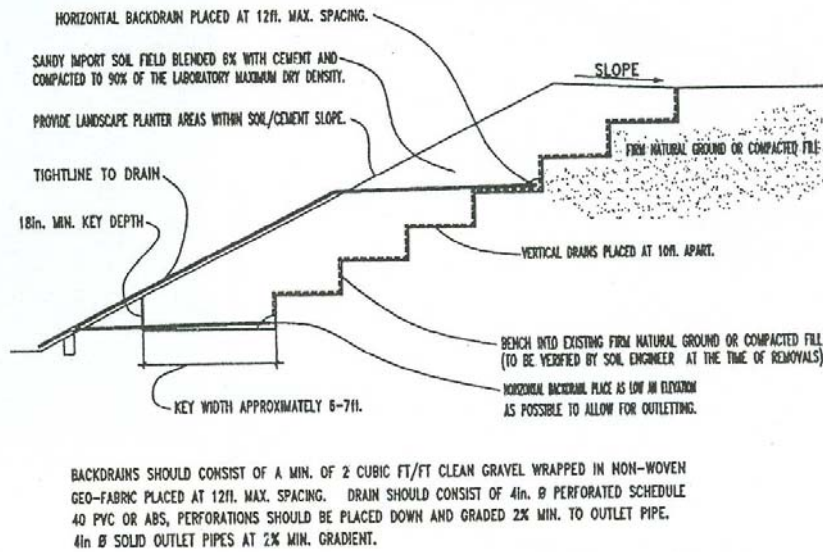

Figure 2.12: Soil cement repair of shallow slope failures (Day, 1997).

### 2.5.5 Repair Using Conventional Structural Members

Among the methods to repair surficial slope failures is the use of small size structural reinforcing members, as shown in Figure 2.13. The reason for using small size (diameter or cross-sectional area) structural reinforcement elements is that shallow slope failures have surficial slip surfaces; thus, the forces exerted on the reinforcing elements are small.

Loehr et al. (2000) used 4 in. × 4 in. × 8 ft. recycled plastic pins to stabilize shallow slope failures along highway slopes and embankments in Missouri. Details of this comprehensive study are presented in Chapter 3. The new technique utilizes a distributed network of plastic pins to provide positive reinforcements to the soils. Figure 2.14 illustrates a profile of recycled plastic pins for stabilizing a potential sliding surface.

Installation of recycled plastic pins can be achieved by different methods. Sommers et al. (2000) used the modified pavement breaker and the pseudo vibratory driving system for vibratory installation of recycled plastic pins to stabilize shallow slope failures. Figure 2.15 depicts installing recycled plastic pins to stabilize shallow slope failures.

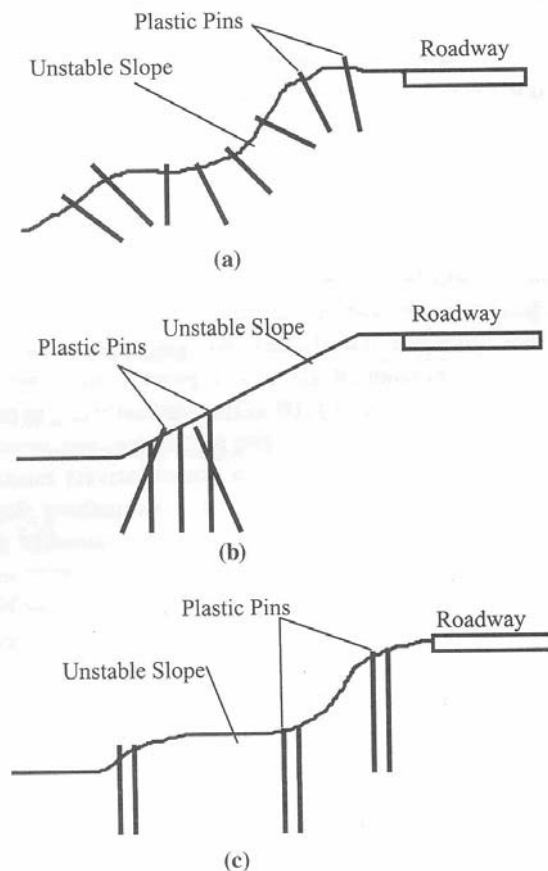

Figure 2.13: Potential schemes for slope stabilization using structural members: (a) soil nailing, (b) reticulated buttress, and (c) soil doweling (after Loehr et al., 2000).

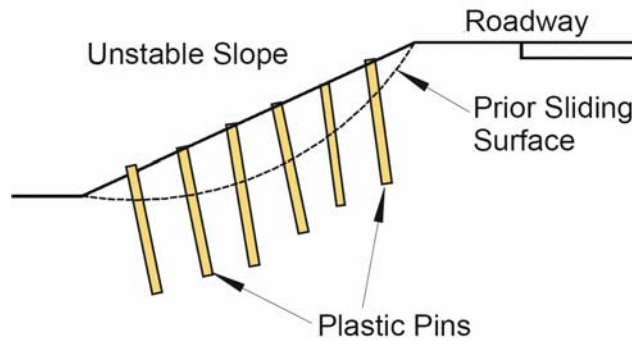

Figure 2.14: Profile of recycled plastic pins stabilizing a potential sliding surface (Loehr et al., 2000).



Figure 2.15: Installation of recycled plastic pins to stabilize surficial failures (after Loehr et al., 2000).

### 2.5.6 Repair Using Launched Soil Nails

Launching soil nails is a proprietary method of Soil Nail Launcher, Inc., which was recently introduced. In this method, soil nails are inserted into the slope face at a high speed utilizing high pressure compressed air. The device that launches the nail is called the soil nail launcher (SNL), which can be attached to the end of an excavator, as shown in Figure 2.16a. Installing launched soil nails is depicted in Figure 2.16b. Typical soil nails can be solid or hollow steel bars. Galvanized soil nails also can be used in highly abrasive environments because they provide resistance to corrosion. Typical dimensions of hollow non-galvanized steel bars are an outer diameter of 1.5 in. (0.12 in wall thickness) and length of 20 ft., as shown in Figure 2.17. The minimum yield strength of the steel bars is 36 ksi. After installing launched soil nails, the slope surface can be treated with erosion mat, steel mesh, and shotcrete. Figure 2.18 shows a slope stabilized with launched soil nails.



(a) Soil nail launcher



(b) Installation of launched soil nails

Figure 2.16: Soil nail launcher used to repair slope failures (SNL, 2007).



Figure 2.17: Launched soil nails of 1.5 in. diameter and 20 ft. in length (SNL, 2007).

The soil nail launcher provides fast installation with minimal impact on the site environment. According to Soil Nail Launcher, Inc., launched soil nails can be installed at a rate of 10 per hour; however, it is difficult to control the penetration length of the soil nail. The compressed air pressure and the properties of the slope soil govern the depth of penetration of launched nails.



Figure 2.18: Highway 363 slope south of Moose Jaw, Saskatchewan, was stabilized with launched soil nails (SNL, 2007).

Hollow perforated nails also can be used as horizontal drains to remove water from slopes and prevent development of pore water pressures that lead to reduced soil strength, as shown in Figure 2.19.



Figure 2.19: Horizontally launched hollow perforated nails act as drains (SNL, 2007).

Launched soil nails penetrate the soil beyond the failure surface and utilize the soil-nail bond (tensile resistance of nails) and the shear resistance of the nail to resist driving forces, as shown in Figure 2.20.

Wendlandt (2006) investigated six landslide sites in Summit County, Ohio, that were stabilized with launched soil nails. Since the soil nailing technology is relatively new, there was a need to evaluate the effectiveness of the launched soil nails as a method of landslide stabilization. Launched soil nails of 1.5 in. in diameter and 20 ft. long hollow steel bars were used.

Wendlandt (2006) conducted field investigations at the landslide sites to identify the types and causes of slope movements, establish locations of the failure plane, establish soil profiles, collect soil samples and subject them to laboratory testing, monitor surficial slope movements, and monitor subsurface slope movements using inclinometers. In addition, stability analysis was performed for each site using GSTABL software, before and after installation of soil nails.

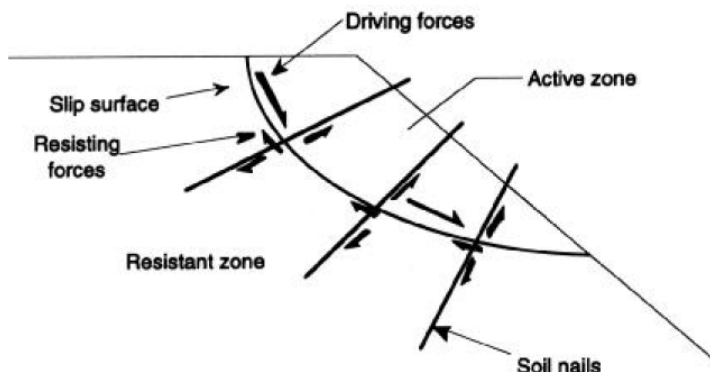

Figure 2.20: Application for soil nails in slope stabilization (FHWA, 2003).

Laboratory test results indicated that the soils present at the six sites consist of silts and clays, with  $c$  ranging from 0 psi to 550 psi and  $\phi$  varying between 15 and 30°. The stability analysis showed that the factor of safety for the slopes after soil nailing varied between 1.30 and 1.70. Results of the investigation showed that the upper parts of the slopes that were stabilized with the soil nails had not moved and that launched soil nailing is an effective method of landslide stabilization.

### 2.5.7 Repair Using Earth Anchors

Earth anchoring systems (e.g., Platipus®) consist of a mechanical earth anchor, wire rope/rod, and end plate with accessories, as shown in Figure 2.21. Earth anchors have been used in many geotechnical applications, including stabilizing surficial slope failures. Repair of surficial slope failures with earth anchoring systems starts with regrading the failed slope. The original failed soil can be used or replaced with granular fill. Slope landscaping and seeding is carried out according to the local specification. Erosion control fabric is installed on the face of the slope (e.g., Pyramat®, which is high-performance turf reinforcement matting). Finally, the earth anchors are installed by pushing the anchor into ground below the failure surface, as shown in Figure 2.22. The wire tendon of the anchor is pulled to move the anchors to its full working position. The wire tendon is locked against the end plastic cap (end-plate) and the system is tightened. Details of installing earth anchors in the ground are shown in Figure 2.23.

There are various commercial anchoring systems available in the market. Platipus® anchors were selected for this research because they are used specifically in geotechnical applications, including deep and shallow slope stabilization. Moreover, Platipus® anchoring systems were used by state departments of transportation and other agencies, including North Carolina DOT, California DOT, Federal Bureau of Prisons (South Carolina), and Hawaii DOT. Personal communications with the North Carolina DOT indicated that they are satisfied with earth anchors for slope stabilization. Moreover, this method cost less compared with the traditional methods used for long-term slope stabilization.

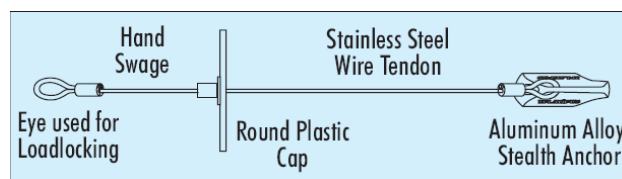

(a) S02E anchor with maximum capacity of 550 lbs.

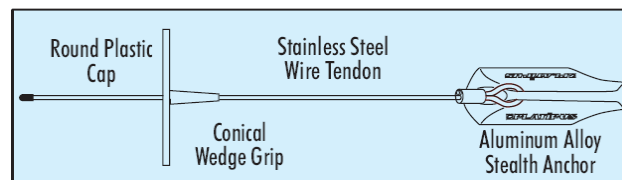

(b) S04E anchor with maximum capacity of 2,200 lbs.

Figure 2.21: Platipus® anchors designed for shallow slope stabilization (Platipus, 2007).

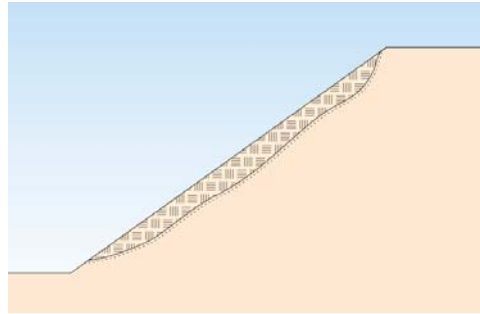

(a) Regrading the failed slope

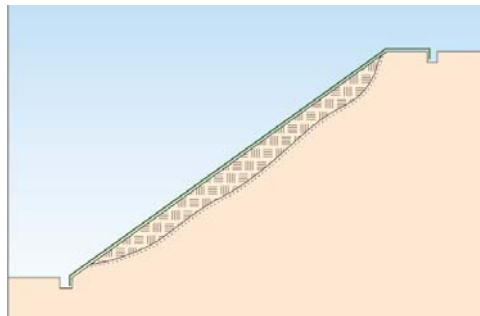

(b) Installing the high performance turf reinforcement mat

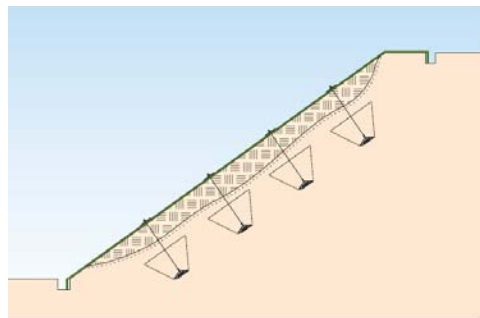

(c) Installing mechanical earth anchors through the mat below the slip surface

Figure 2.22: Surficial slope failure stabilization by earth anchoring systems (after Platipus®, 2007).

Earth anchors are used to stabilize a surficial failure along the Highway 26 cut slope. The 1H:1V slope failed after a heavy rainy season. Figure 2.24a depicts the shallow slope failure. The Platipus S4 anchor was used to repair the shallow slope failure. The construction was fast and simple and at 5 ft. spacing. It was reported that Caltrans (California DOT) was satisfied by this repair method, particularly the speed and simplicity of construction (Platipus, 2007). Figure 2.24b depicts the repaired slope.

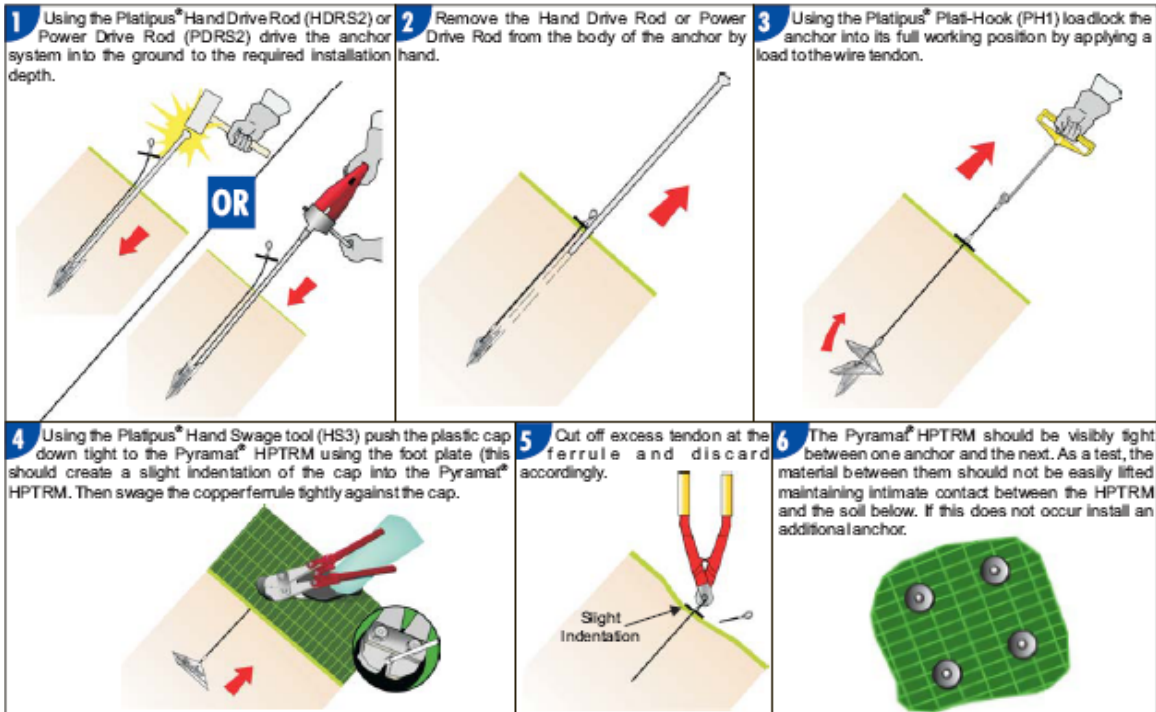

Figure 2.23: Installation of earth anchor (Platipus, 2007).



(a) Surficial slope failure

(b) Slope repair using earth anchors

Figure 2.24: Slope failure and repair along the Highway 26 cut slope in Calaveras County, CA, (Platipus, 2007).

## **2.6 Slopes and Surficial Slope Failures in Wisconsin**

Slope failure in Wisconsin generally occurs on highway cut slopes and embankments. The characteristics and causes of slope failures vary, as they are influenced by slope geometry, soil type and properties, climate conditions (saturation conditions and seepage), and workmanship/construction. Causes of slope failure are usually site-dependent; however, failures generally happen when driving forces surpass resisting forces and the soil mass moves downslope. Details of shallow slope failures in Wisconsin are presented in Zimmer and Titi (2007) and summarized below.

Slope failures on WisDOT projects can be divided into two categories: deep and surficial. Deep slope failures usually consist of relatively large soil masses that have displaced along a failure surface, which may be several feet or more below the ground surface. Deep slope failures typically can be characterized by a circular failure surface such as an embankment failing over a weak foundation. Surficial slope failures usually occur within the near surface soils of a slope, such as a layer of topsoil sliding down the face of the slope.

Selection and execution of a slope stabilization scheme (repair method) is necessary once a slope failure is identified on WisDOT projects. Various methods can be used to correct slope instabilities. Some methods are more suitable for stabilizing shallow failures than deep failures, while some methods can be used to repair both types. Methods that are commonly used for deep slope failure repairs include slope flattening, geosynthetic reinforcement, toe berms, reconstruction with granular materials, retaining structures, lightweight fill, relocation of roadway, land bridge, and soil nailing. For surficial slope failures, repairs include regrading slopes, improved drainage, and bioengineering.

A variety of methods listed above have been used on WisDOT projects. Sometimes a combination of methods is used to stabilize a failed slope. Other methods are used based on contractor/practical experience rather than engineering analysis. The methods used by WisDOT generally are not exclusive to one region within WisDOT, but have been used or at least considered in all of the WisDOT regions shown in Figure 12.25.

### **2.6.1 Slope Design**

WisDOT uses the Facilities Development Manual (FDM) process in designing roadways. The FDM outlines the policy, procedural requirements, and guidance encompassing the uniform development of the highway system in the state. The FDM is based on sound engineering practices and sensitive environmental concern. Safety of the travelling public typically is at the forefront of the FDM process. The responsibility of the engineer is to design a safe highway infrastructure. Many of the decisions regarding slopes, including their location, heights and steepness, are directly affected by the FDM policies.

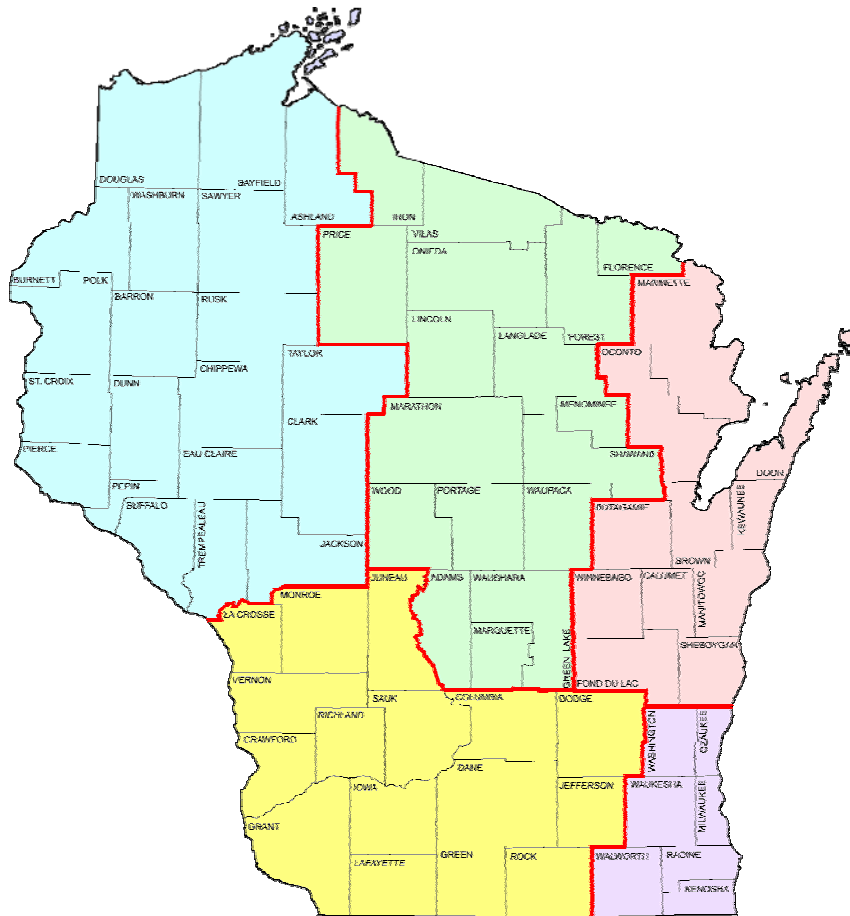

Figure 2.25: Wisconsin DOT regions.

Side slopes are typically characterized in the FDM in one of three ways:

1. Recoverable: Fill slopes that are 4 Horizontal to 1 Vertical (4H:1V) or flatter or cut slopes that are 3H:1V or flatter.
2. Non-recoverable, but traversable: Fill slopes that are between 3H:1V and 4H:1V.
3. Critical: Fill or cut slopes that are steeper than 3H:1V.

A slope is considered critical when the potential for a vehicle to overturn while leaving the roadway becomes high. When a slope is deemed critical a barrier may be warranted. During the design process, an engineer often will design slopes to fall outside of the critical classification. This usually means that additional right-of-way is purchased in such locations and slopes are flattened as much as possible. Occasions exist when restrictions prevent the acquisition of additional land for providing flattened slopes. In these cases, slopes are constructed at angles steeper than 3H:1V.

The FDM does not have any specifications as to when a slope becomes so steep that a retaining wall must be used. A general approach by WisDOT engineers is to not design slopes steeper than 2.5H:1V to 2H:1V because of the potential for slope failure.

The FDM makes reference to using the AASHTO Policy on Geometric Design of Highways and Streets for guidance (GDHS). According to the GDHS, walls should be considered where space restrictions result in slopes steeper than 2H:1V. Therefore, with the exception of cut slopes in rock, a retaining wall typically is planned for slopes steeper than 2H:1V.

Despite designs that include flattened slopes, slope failures still occur on WisDOT projects. A slope stability analysis typically is not performed on slopes flatter than 2H:1V unless there are known problems at a specific location.

### ***2.6.2 Surficial Slope Failures and Repair***

Surficial slope failure typically is the most common type of slope failure on WisDOT projects. Such failures often happen during or just after prolonged rainfall events, mostly in early spring or late fall when precipitation amounts are generally heaviest and the landscaping of slopes has not yet been completed. The top few feet of the soil usually are affected, and slopes steeper than 2.5H:1V are the most prone to surficial failures. In many cases, the topsoil layer and the soil directly beneath it tend to fail. Most surficial slope failures resemble infinite slope failures.

During wet times of the year, the slope face becomes saturated during periods of heavy rainfall and water runoff over the slope face. The saturation of the near surface soils increases pore water pressure, and, as a result, decreases the shear strength of the surficial soils. The seepage pressure also increases the driving forces on the slope and the combined effect reduces the factor of safety of the slope and the subsequent slope failure.

#### **Regrading Slopes**

The regrading of slopes generally consists of placing the soils from a slope failure back on the failed area. Sometimes the failed areas are allowed to dry prior to returning the material to the failed slope, which improves shear strength when the soil is re-compacted. Sometimes the failed soil is pushed back to the failure area without time to dry. In this case, the failure of the slope is more likely to reoccur. Oftentimes, the failed soil is completely removed and replaced with a different material. Regrading slopes usually involves restoring the slope to its original geometry shown on the plan cross-sections.

A reconstruction project recently was completed to expand STH-164 (Waukesha County) into a four-lane highway in each direction. The expansion required cut sections in the old highway slopes, as illustrated in Figure 2.26a.

The Soil Conservation Service (SCS) survey indicated that the predominant soil types in the vicinity of the slope consist of Hochheim soil, which is highly calcareous loam glacial

till. The substratum consists of gravely loam glacial till. Subsurface exploration was conducted at the site and consisted of soil borings. Test results indicated that the soil consists of silty sand and sandy silt with variable gravel content. High blow counts were recorded during a Standard Penetration Test (SPT), which indicated the presence of cobbles and boulders in the soil.

The height of the slope ranges from 35 to 40 ft. at a slope of 2.5 H:1V (Figure 2.26a). The slope was graded during the summer season, which is often rainy in Wisconsin, then seeded in late fall. The erosion control mat was placed over the slope face after it was seeded. The seed mixture was placed on the slope face after at least 4 in. of topsoil (silty clay loam) was placed.

A shallow slope failure was observed about four months after the slope was graded. An initial field survey showed that the failure occurred on the east side of the road with an approximate length of 300 ft. The failure consisted of a surficial topsoil layer sliding down the face of the slope, which was sparsely vegetated when the slide occurred. The slope failure occurred in an earth cut section and continued to worsen during the spring thaw until it covered two thirds of the slope length from the top. Figure 2.26b shows details of the slope failure and Figure 2.26c depicts the failure. A field investigation and survey were conducted to collect information and soil samples at the slope failure site. Field observations showed that the soil was wet, with moisture content variation between 28 and 32%. Water was allowed to sheet drain over the face of the slope.

The slope was excavated into a glacial drumlin. The highest point on the slope generally coincided with the highest point of the drumlin. The slope failure occurred at the highest point on the slope. Therefore, the amount of water sheet draining over the face of the slope in the location of the failure may not have been very significant. In addition, field observations during the initial slope grading did not determine that water was seeping from the earth cut onto the face of the slope.

Moreover, measurements of the slip surface depth were conducted by utilizing a steel probe that was pushed into the failed soil mass at 3-ft. intervals. The depth of failed soil was then measured. It was noticed that the maximum accumulation depth of the failed soil was measured as 24 in. near the toe of the slope. The profile and the depth of the failed soil were used in the stability analysis of the slope.

The average thickness of the failed soil was 18 in. The length of the failure was approximately 67 ft., which is very long compared with the thickness of surficial failed soil. Therefore, a basic stability analysis was conducted, assuming an infinite slope failure. The analysis was conducted based on an estimated angle of internal friction ( $\phi=25^\circ$ ), slope angle  $\beta= 22^\circ$ , and the assumptions of existing and absence of ground water. The analysis showed a variation of the factor of safety against failure between 1.17 and 0.49. The actual factor of safety remains unknown since the actual saturation condition at the time of failure was not determined.

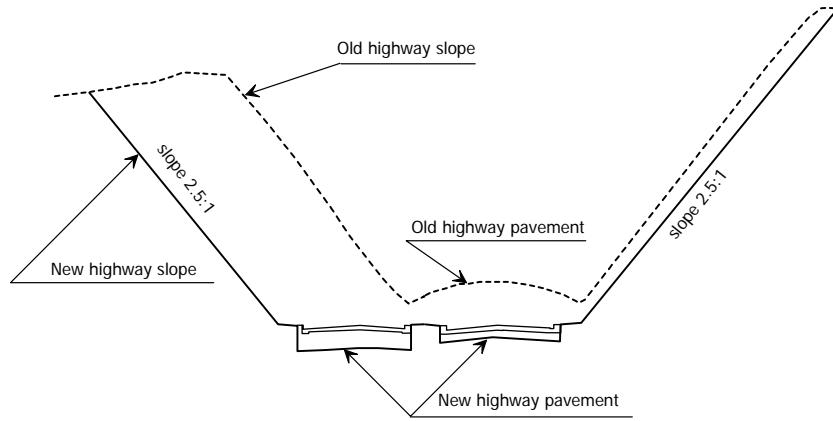

(a) Cross-section of the reconstructed highway at Sta. 299+00

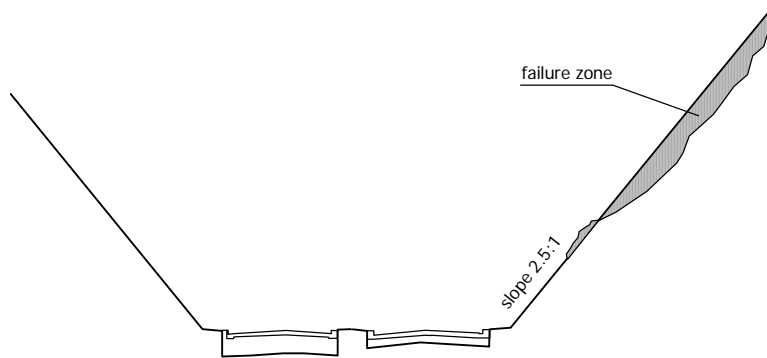

(b) Shallow slope failure at Sta. 299+00



(c) Picture of the shallow slope failure

Figure 2.26: Shallow slope failure of the reconstructed STH 164 at Sta. 299+00.

Repair of the failed area was conducted about six months after the slope failure occurred. The failed material was left to dry and the slope was then re-graded to the pre-failure grades using a small bulldozer. After regrading, the slope was seeded and covered with an erosion control mat. Thereafter, measurement of the topsoil depth was performed by pushing a steel probe manually at 3-ft. intervals. Topsoil depth ranged from approximately 5 to 18 in. Within several weeks of repairs, vegetation was growing on the slope face. Currently, vegetation continues to grow and further failures have not been observed. Figure 2.27 depicts the repaired slope.

### Soil Removal and Riprap Placement

A shallow slope failure occurred shortly after the cut slope construction was completed on STH-16 in Waukesha County. The slope is approximately 40 to 55 ft. high and as steep as 2.5H:1V. Topsoil (min. 4 in.) was placed on the slope face to complete landscaping. The slope was then seeded and covered with an erosion control mat.



Figure 2.27: Pictures of the repaired shallow slope failure at STH-164.

According to the SCS Soil Survey, the natural soil types of this area consist of Fox, Hochheim, and Theresa soils. Fox soils consist of loamy soils underlain by calcareous sand and gravel glacial outwash. Theresa soils generally consist of silty clay loam over calcareous loam glacial till. The soil types observed during construction consist of silty sand to sandy silt containing variable amounts of gravel, cobbles, and boulders, and are similar to those listed in the soil survey.

The slope failure consisted of the surficial topsoil layer sliding down the face of the slope. The failure surface generally was parallel to the face of the slope and the underlying stable material and also resembled an infinite slope failure. During the original grading activities in the failure area, a significant amount of seepage was observed from the cut slopes onto the face of the slope. Figure 2.28 depicts the slope failure.



Figure 2.28: Shallow slope failure at STH-16 with water seeping out of the slope face.

The slope was repaired shortly after failure by removing the failed soil mass and replacing it with a layer of riprap or other large stone. Typically, a heavy riprap geotextile is placed on the slope prior to the riprap placement. A “keyway” typically is excavated at the toe of the slope prior to placement of the riprap. The “keyway” stabilizes the mass of riprap. The original slope configuration was not changed during repair and repeat slope failures have not occurred. Figure 2.29 shows a picture of the repaired slope. This repair method is generally effective, although it has the potential to cause additional failures if used incorrectly. One case of potential failure is when the underlying soil is weak and soft and it cannot resist the increased driving forces from the riprap. This method is not considered visually appealing.

In addition, implementation of this repair is based on the practical experience of the grading contractor rather than through engineering design or analysis.



Figure 2.29: Riprap repair of shallow slope failure at STH-16.

### Improving Drainage

In many instances, shallow slope failures on WisDOT projects are caused by seepage or water drainage over the faces of slopes. Seepage leads to increased driving forces,

reduced shear strength of the soil, and the subsequent failure of the slope. If water can be drained out of the slope, then the slope stability will be improved. Water can be intercepted and drained from the face of a slope by methods such as installing subsurface drains along the face of the slope. Inlets can be installed along the roadway or at the top of the slope to prevent water from discharging over the face of the slope. Small earth berms also can be constructed at the top of slopes to prevent water from flowing over the face of the slopes.

A foreslope along an approximate 500 ft. section of a roadway embankment on STH-16 (Oconomowoc Bypass) in Jefferson County was constructed as an earth fill section. The fill soil used to construct the slope generally consisted of sand. During summer, the sandy soil experienced sloughing problems. Water was observed seeping from the face of the slope, which is approximately 4 ft. high and as steep as 4H:1V. The water was saturating the sandy soil of the slope, causing it to become unstable. It would be very difficult to grade and landscape the slope if the seepage and sloughing continued. It should be noted that this is a shallow failure in which the surficial soils moved down the face of the foreslope between the roadway and the drainage ditch parallel to the roadway.

It was decided to install a subsurface drain along the shoulder of the roadway at the approximate depth of the foreslope. The underdrains consisted of a 6-in. diameter perforated draitile placed in a trench filled with clean aggregate. The trench was lined with a geotextile prior to placing the aggregate and draitile. The draitile was discharged away from the face of the foreslope. After the draitile was installed, seepage was no longer observed and the slope was graded and landscaped as planned. Removing the water stabilized the slope since the effective stress of the soil increased, which in turn increased the shear strength of the soil. Soil with a higher shear strength resulted in a slope with a higher factor of safety. After installation of the underdrains, no slope failures have occurred.

### Bioengineering

Bioengineering presents several alternatives for stabilizing slopes, which generally include using vegetation. Some methods include live staking, branch packing, brushlayer, live cribwall, and live gabion. Vegetation can provide reinforcement to the surficial soils. Essentially, vegetation that is strategically placed can enhance the shear strength of the soils that comprise the slope. Soils with higher internal strength will result in a slope with a higher factor of safety.

Several slopes became unstable during construction of CTH K in Vernon County. Water was observed seeping from the slope faces. Difficulties were expected in trying to grade and seed the slopes. It was decided to use a bioengineering method of placing willow stakes in the unstable slopes. Live staking consists of placing sections of plants that are cut into lengths of several feet and placed in the ground generally perpendicular to the slope face in a predetermined pattern. It is best to use a species of plant that roots easily.

The live staking (shown in Figure 2.30) used on CTH K has worked well. The slopes remain stable and water seeping from the face of the slope no longer is observed. The live staking reinforced the soils and increased the factor of safety of the slope.

Topsoil and grass seed is an effective method of stabilizing surficial slope failures by placing grass vegetation on the slope face. WisDOT uses a number of erosion control products/mats on projects to assist in the vegetation of slopes. Most of the surficial failure problems occur before grass vegetation takes root. Once grass vegetation takes root on most slopes, the amount of surficial failures are greatly reduced.

The roots from grass vegetation can remove moisture from the slope and reinforce the soil on the slope face. Grass vegetation can prevent erosion by binding soil particles and preventing particles from being carried down slope. Grass vegetation is effective only in dealing with surficial failures. The root system is not deep and therefore cannot be used to stabilize deep-seated failures.

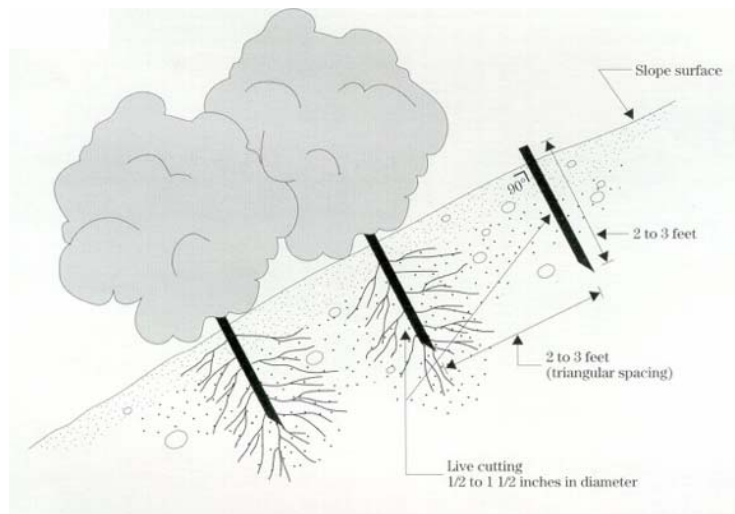

(a) Live staking details



(b) Stabilized slope

Figure 2.30: Live staking application at County Trunk Highway K.

## Chapter 3

### Stabilization of Shallow Slope Failures Using Short Structural Members

This chapter presents a synthesis of the literature materials collected and reviewed on the stabilization of surficial slope failures using structural members. The chapter includes details of the design and analysis methodology, material properties, construction, case history and field performance, and cost.

#### 3.1 Introduction

A general description of using reinforcing structural members for shallow slope stability was presented in Chapter 2. The literature search and review conducted in this study indicated that the use of structural members for surficial slope failures is not common practice; however, there is great interest in this methodology, which has led to a major research study that was recently completed in Missouri (Loehr and Bowders, 2007). Based on personal communications and phone surveys with selected state highway engineers, the research team identified three innovative methods of surficial slope stability:

1. Installing small size structural members by conventional methods
2. Installing launched soil nails
3. Installing earth anchoring systems

This section describes the first method in detail, including the design and analysis methodology for structural members, material properties of the structural members used, construction methods, cost-effectiveness, and case histories. It should be noted that there is little documented information available on this subject due to the following reasons: (1) this method is not very commonly used and is currently being researched by some state highway agencies (Missouri and Iowa); and (2) many state highway agencies deal with surficial slope failures as part of the routine maintenance work performed on the district level. The second and the third methods (launched soil nails and earth anchors) were described in Chapter 2. The cost-effectiveness for these methods also will be presented in this chapter.

Shallow slope failures produce mass movements that are limited to the surficial soil. Forces that drive shallow slope failures are small in magnitude compared with forces that drive deep slope failures and landslides. Consequently, the use of small size structural members is an appropriate concept to stabilize shallow slope failures.

Structural members installed into sloped ground increase soil resistance to the forces driving slope instabilities. These members can be prefabricated or cast-in-place. Prefabricated members include small size piles such as steel pipes, timber, plastic lumber, and precast concrete. Cast-in-place members are installed by drilling a small hole in the

face of the slope and filling it with materials such as concrete or stones (e.g., stone columns). This report deals only with prefabricated structural members.

### 3.2 Design and Analysis Methodology

The design and analysis of reinforcing structural members for shallow slope stability include:

- (1) Determining the required size of the reinforcing structural members (cross-sectional area and length) based on the material type of the reinforcing structural member, driving force, slope geometry, and the depth of the potential failure surface.
- (2) Determining the installation patterns and spacing of the reinforcing structural members
- (3) Determining the orientation of the reinforcing structural members (vertical versus perpendicular to slope face)
- (4) Identifying the required factor of safety

The design and analysis of small size structural members to resist surficial slope instabilities is presented. The basics of this method are obtained by studying the behavior of short structural members as they interact with the surrounding soil. Details of this method are given by Liew (2000) and Loehr and Bowders (2007). Computer programs such as SLOPE/W provide design and analysis tools that include vertical member reinforcements such as piles, nails, and anchors.

#### 3.2.1 Stability Analysis of Slopes

The stability of slopes can be evaluated using conventional methods in which a potential failure surface is assumed. Then, a factor of safety is calculated from the equilibrium of the sliding soil mass, as shown in Figure 3.1. The factor of safety is defined as follows:

$$FS = \frac{s}{\tau} \quad (3.1)$$

where  $s$  is the available shear strength and  $\tau$  is the equilibrium shear stress that is needed to maintain a stable slope. The equilibrium shear stress is expressed by:

$$\tau = \frac{s}{FS} \quad (3.2)$$

The available shear strength ( $s$ ) is reduced by a factor of safety ( $FS$ ) that will make the factored shear stress ( $s/FS$ ) just in a state of equilibrium with the shear stress ( $\tau$ ). This is known as the limit equilibrium procedure.

The shear strength of the soil can be evaluated using the Mohr-Coulomb equation. In terms of total stress, the equilibrium shear stress can be written as:

$$\tau = \frac{c + \sigma \tan \phi}{FS} \quad (3.3)$$

where  $c$  is the cohesion,  $\phi$  is the angle of internal friction of the soil, and  $\sigma$  is the total normal stress on the shear plane (sliding surface). When the shear strength is expressed in terms of effective stress, then the equilibrium shear stress is expressed by:

$$\tau = \frac{c' + (\sigma - u) \tan \phi'}{FS} \quad (3.4)$$

where  $u$  is pore water pressure, and  $c'$  and  $\phi'$  are the drained shear strength parameters of the soil.

Stresses and factor of safety are calculated from the static equilibrium of the sliding soil mass along a potential slip surface. The analysis is repeated for other assumed slip surfaces and the corresponding factor of safety is calculated. The critical slip surface is the potential failure surface that results in the lowest factor of safety.

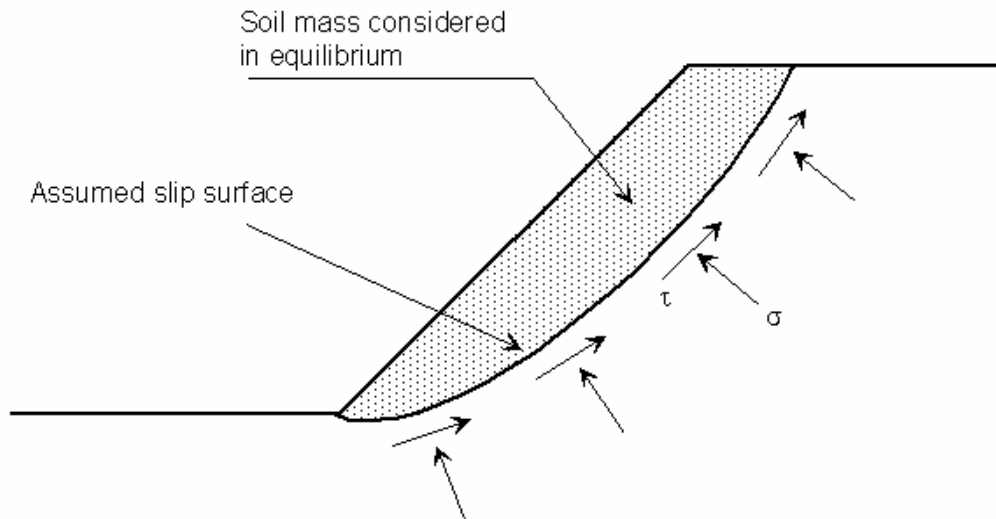

Figure 3.1: Slope with assumed slip surface used for equilibrium analysis in slope stability.

The procedures of slices can be used to determine the factor of safety. In these methods, the soil mass above the assumed sliding surface is subdivided into vertical slices, as shown in Figure 3.2. The equilibrium of the slices is considered to determine the normal and shear forces on the assumed sliding surface and the factor of safety. The process is repeated for other potential sliding surfaces until the most critical sliding surface (that yields the smallest safety factor) is found. Such a factor of safety is assumed to represent the stability conditions of the analyzed slope.

### 3.2.2 Stability of Slopes Reinforced with Structural Members

Liew (2000) and Loehr et al. (2004) developed a procedure for stability of slopes reinforced with recycled plastic members. The method uses a limit state design approach to calculate the resistance provided by the reinforcing members. The limit states method includes the failure of the soil above or below potential sliding surfaces as well as the structural failure of the reinforcing member. Details of this method are described below.

For reinforced slopes, the methods of slices can be used except that a force,  $F_R$ , due to a reinforcing member is added to the other forces acting upon the slices, as shown in Figure 3.3. The force  $F_R$  can be included in the equilibrium equations that are used to solve for the overall factor of safety of the slope. Thus, the reinforcement force  $F_R$  in each structural member must be estimated beforehand and then used as input for the stability analysis. The main challenge in analyzing reinforced slopes is establishing the magnitudes of these forces. For limit equilibrium analyses,  $F_R$  generally is taken as the maximum resisting force that can be developed for the reinforcing element. Therefore, the reinforcement force  $F_R$  is referred to as the “*limit resistance*” (Loehr et al., 2004).

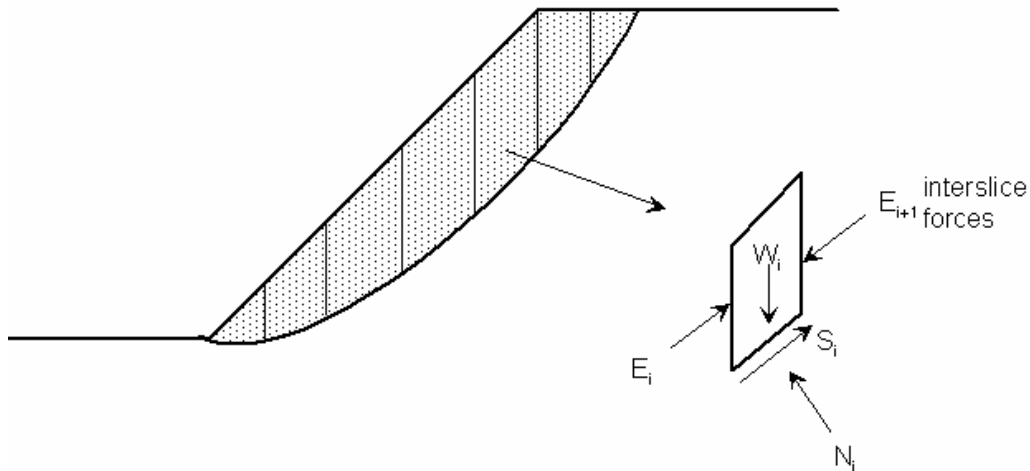

Figure 3.2: Individual slice under equilibrium in an analysis using procedures of slices.

As shown in Figure 3.4, each reinforcing member will provide a resisting force based on the location of the intersection of the sliding surface and the reinforcing member. The part of the reinforcing element below the sliding surface provides an anchoring mechanism for the part above the sliding surface that acts as a cantilever beam. Intuitively, the magnitude of the resisting force offered by a reinforcing element varies with position along the reinforcing member at which a potential sliding surface intercepts the member. Thus a “*limit resistance curve*” is needed to define the magnitude of the resisting force provided by the reinforcing member as a function of the location where a potential sliding surface crosses the member.

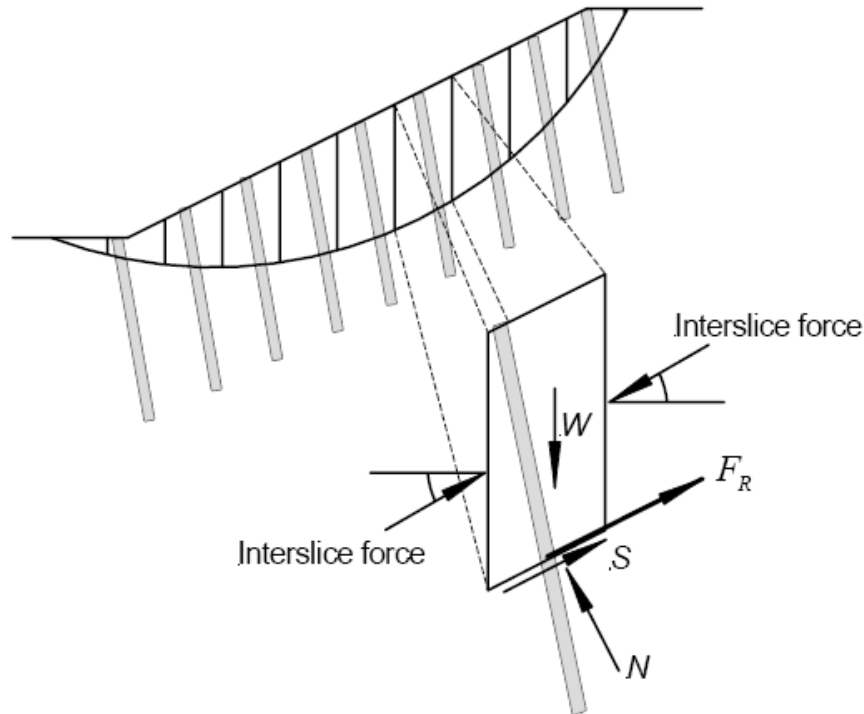

Figure 3.3: Reinforcement force ( $F_R$ ) on an individual slice in the methods of slices (after Loehr and Bowders, 2007).

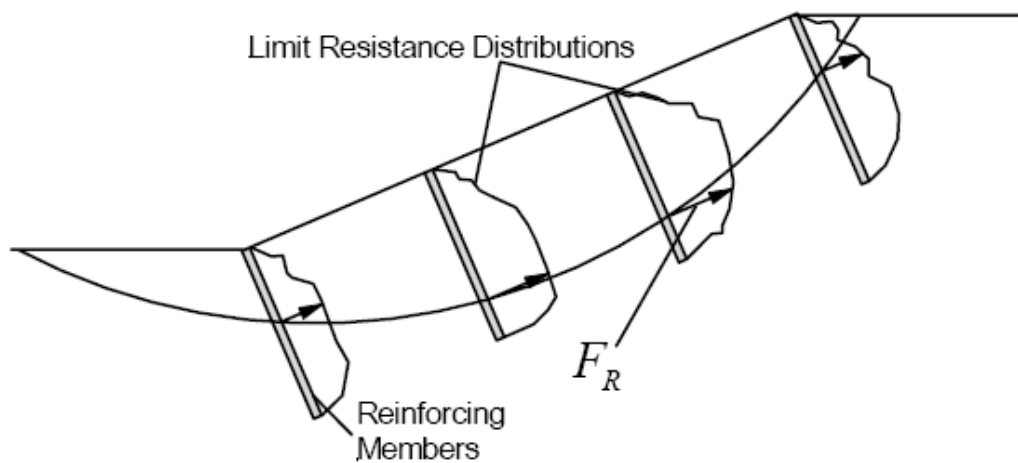

Figure 3.4: Example of distributions of limit resistance for multiple members in a reinforced slope (after Loehr and Bowders, 2007).

### 3.2.3 Development of Limit Lateral Resistance Curves

To estimate the limit lateral resistance of a reinforcing member, a limit state design approach was used in which three potential failure mechanisms are considered (Liew, 2000; Loehr et al., 2004; and Loehr & Bowders, 2007):

- “Failure Mode 1” in which failure of soil around or between reinforcing members occurs
- “Failure Mode 2” in which failure of soil occurs due to insufficient anchorage length
- “Failure Mode 3” in which structural failure (shear and/or bending) of reinforcing members occurs due to loads exerted by the sliding soil mass

Separate limit resistance curves can be developed for each limit state (failure mode), as illustrated in Figure 3.5. These limit resistance curves are dependent on soil type and reinforcing element strength and stiffness. From these individual curves, a “composite” limit resistance curve that corresponds to the most critical component of resistance at each sliding depth is established by taking the component with the least resistance (i.e., the critical failure mode) at each sliding depth.

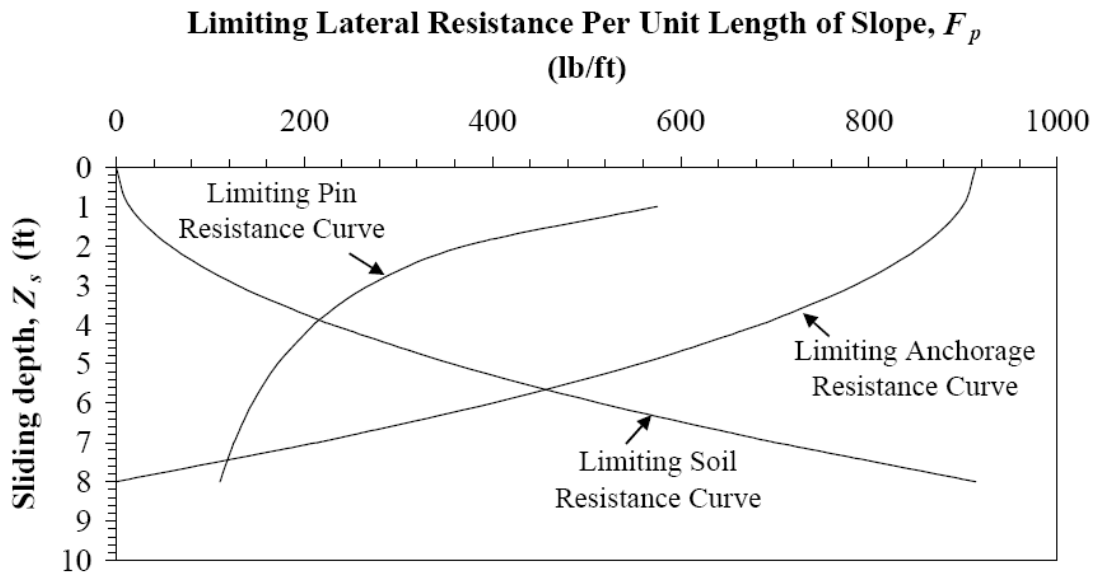

Figure 3.5: Typical distributions of limit resistance developed for the three limit states considered (After Loehr et al., 2004).

### **Failure Mode 1 – Limit Soil Resistance**

This mode considers failure of the soil above the sliding surface in which the sliding soil flows around or between reinforcing members, as depicted in Figure 3.6a. To calculate the limit resistance for this failure mode, the lateral pressure at which failure of the soil will occur must be estimated. This pressure is referred to as the “limit soil pressure” and is denoted  $p_u$ . The method proposed by Ito and Matsui (1975) is used here to calculate the limit soil pressure. This method is versatile - it can be extended to members composed of non-conventional materials. The method also is conservative. Other methods available for calculating the limit soil pressure generally are based on load tests for full-scale conventional steel and concrete piles, which are considerably different in size and

stiffness than the recycled plastic members.

Again, the limit soil pressure will cause the soil to fail laterally. This limit pressure is dependent on the vertical effective stress that varies with depth. Assuming that the limit soil pressure is mobilized simultaneously along the length of the reinforcing member above the sliding surface, the total limit resistance (Failure Mode 1) can be obtained by integrating the limit soil pressure over the length of reinforcement above the sliding surface, as shown in Figure 3.7. This total limit resistance force is assumed to act at the sliding surface, as shown in Figure 3.7b. This makes it simply accounted for in a stability analysis.

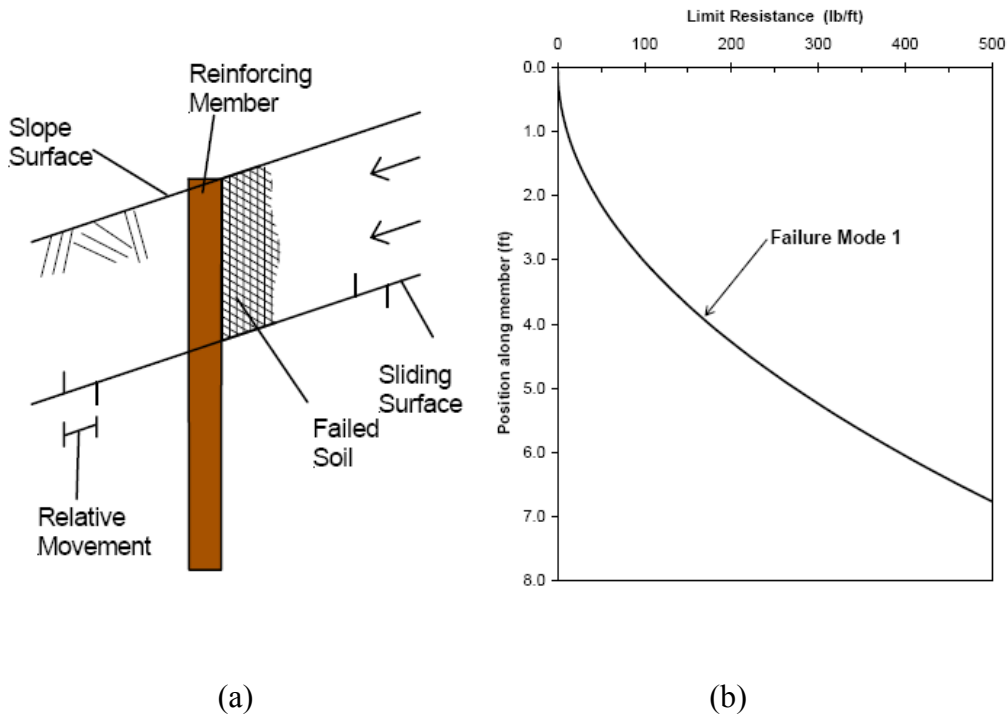

Figure 3.6: (a) Schematic illustrating Failure Mode 1 and (b) Limit resistance curve for failure mode 1 (Loehr & Bowders, 2007).

To establish a complete limit resistance curve describing the total resistance for Failure Mode 1 as a function of sliding depth (Figure 3.5) the sliding surface is assumed to intercept with the reinforcing element at different depths. For each depth, the total limit resistance force is calculated by integration, as described above. It is noted from Figure 3.5 that the total resistance increases from a minimum value at the ground surface to a maximum value at the tip of the reinforcing element. Figure 3.6b shows the calculated limit resistance curve for Failure Mode 1.

A slope stability analysis usually is performed, assuming a plane strain condition in which a cross-section of the unit width of the slope is considered. The total resisting forces computed by integrating the limit soil pressure are divided by the longitudinal spacing between the reinforcing members to produce values of the limit force per unit width suitable for plane strain stability analyses.

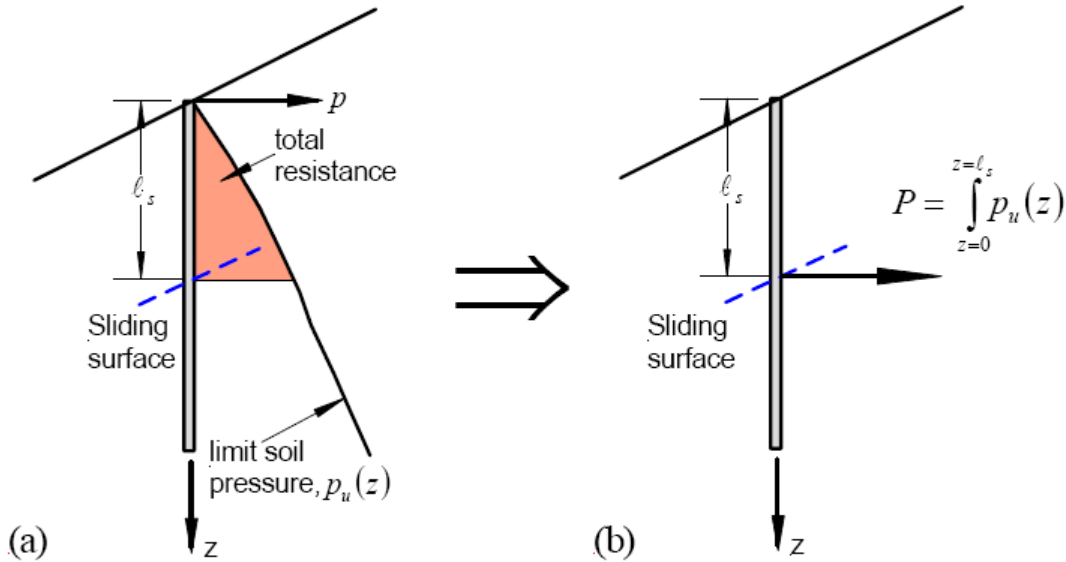

Figure 3.7: Schematic illustrating calculation of limit resistance force: (a) limit soil pressure and (b) equivalent lateral resistance force (after Loehr et al. 2007).

**Failure Mode 2 – Limit Anchorage Resistance**

In this mode, the soil below the sliding surface is assumed to fail while the reinforcing member is anchored in the moving soil above the sliding surface, as shown in Figure 3.8a. The limit state considers insufficient anchorage length of the reinforcing member beyond the sliding surface that provides passive resistance equal to or greater than that exerted by the sliding soil mass on the part of the reinforcing element above the sliding surface. The passive failure of the soil below the sliding surface is assumed to be governed by the same limit soil pressure ( $p_u$ ) used for Failure Mode 1 and a similar procedure is used to calculate the limiting anchorage resistance. This is calculated by integrating the limiting soil pressure ( $p_u$ ) over the length of the reinforcing element extending from the sliding surface to the tip of the member, as shown by the shaded zone in Figure 3.9. Again, it is assumed that the full limiting soil pressure is mobilized over the entire length of the reinforcing member below the sliding surface. The total resisting force for a particular sliding depth also is replaced with an equivalent force for stability analysis (Figure 3.9b).

The distribution of limiting resistance for the anchorage limit state can be calculated by computing the total resisting force for different sliding depths (Figure 3.5). The limiting resistance for Failure Mode 2 increases from zero for a sliding surface passing through the lower end of the reinforcement (no anchor) to a maximum for very shallow sliding surfaces, as shown in Figure 3.5. Figure 3.8b shows the calculated limit resistance curve for Failure Mode 2.

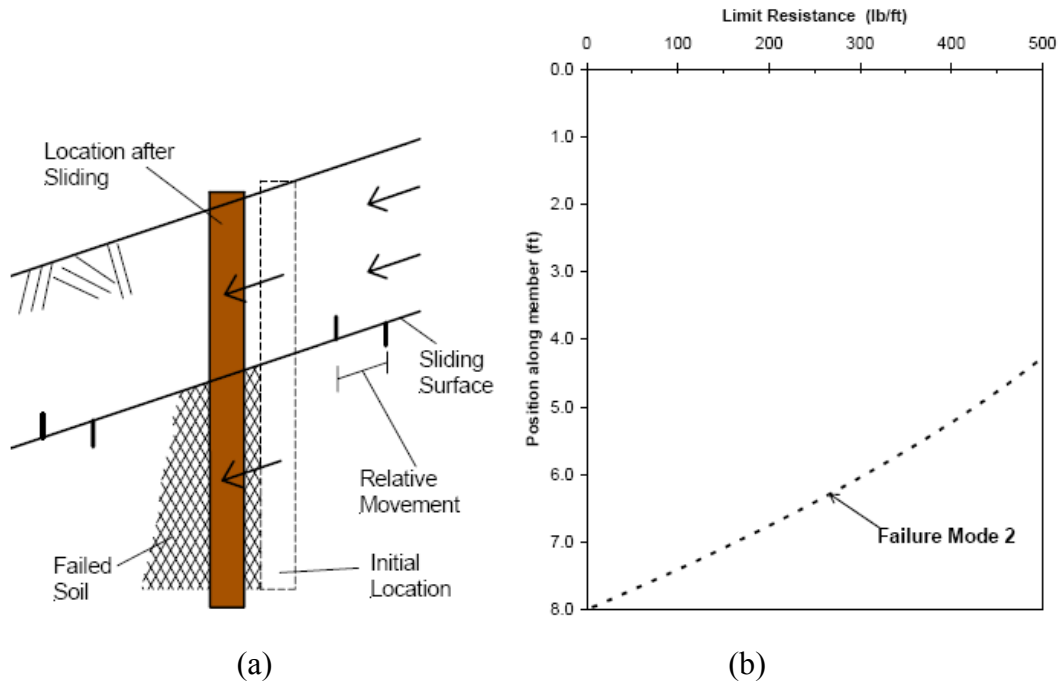

Figure 3.8: (a) Schematic illustrating Failure Mode 2 and (b) Limit resistance curve for Failure Mode 2 (Loehr & Bowders, 2007).

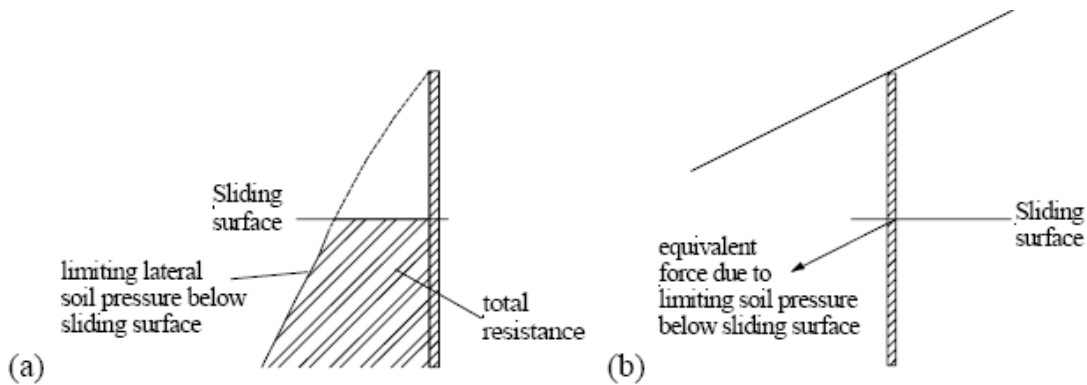

Figure 3.9: Graphical illustration for computing limit anchorage resistance: (a) integral of limiting soil pressure and (b) equivalent total resisting force (after Loehr et al., 2004).

### **Failure Mode 3 – Limit Member Resistance**

It is important to consider the structural failure of reinforcing members in the stability analysis of a reinforced slope. Structural members can fail under excessive moment or under excessive shear. For a given sliding surface, application of the limiting lateral soil pressures may lead to bending moments and/or shear forces that exceed the capacity of the reinforcing member. This means that the reinforcing member will fail prior to full mobilization of the limit soil pressures. In such a case, the stabilizing forces calculated by considering the failure of the soil alone will be over-conservative.

Loehr et al. (2004) used a factored lateral soil pressure of the form

$$p'(z) = \alpha p_u(z) \quad (3.5)$$

where  $p'(z)$  is a factored pressure and  $p_u(z)$  is the limit soil pressure. The factor  $\alpha$  produces a distribution of shear (or moment) such that the maximum shear (or maximum moment) just equals the shear (or moment) capacity of the reinforcing member. To establish the magnitude of  $\alpha$  for a particular sliding depth, an elastic analysis is performed to establish the distribution of shear and moment in the reinforcing member when subjected to the limit soil pressures. Considering bending moments,  $\alpha$  is calculated as

$$\alpha = \frac{M_{ult}}{M_{max}} \quad (3.6)$$

where  $M_{max}$  is the maximum moment determined from elastic analyses and  $M_{ult}$  is the moment capacity of the member. The factor  $\alpha$  is then applied to the limiting soil pressures (Equation 3.5) to determine the factored pressures to avoid structural failure of the reinforcing member in bending. The limit resistance is computed using the factored pressure distribution in a manner similar to that used for the other limit states considered (Figures 3.7 and 3.9).

The factor  $\alpha$  is a function of the sliding depth because the distribution of moment, and the maximum moment are functions of the sliding depth. Thus, the process is repeated for different sliding depths to establish a limit resistance curve for Failure Mode 3, as shown in Figure 3.5. A similar approach is used to consider shear. Nevertheless, Loehr et al. (2004) indicated that bending moments are the controlling factor for recycled plastic members. Additional details regarding the calculation of  $\alpha$  are provided in Loehr and Bowders (2003).

A “composite” limiting resistance curve that accounts for all of the failure modes is obtained by taking the least of the three limit resistance curves shown in Figure 3.5. Such a curve is shown in Figure 3.10. This composite curve then is used in a conventional slope stability analysis to determine the factor of safety for a reinforced slope.

### **Calculating the Limit Soil Pressure**

The Ito and Matsui method (Ito and Matsui, 1975) can be used to calculate the lateral force acting on a row of piles due to the surrounding soil undergoing plastic deformations as shown in Figure 3.11. The soil between adjacent piles in a row is assumed to be in a Mohr-Coulomb state of failure, as indicated by the shaded area in Figure 3.12. In their derivation, Ito and Matsui assumed that the pile does not deform in the axial direction and the pile is rigid compared with the surrounding soil. Based on this theory, the force per unit length acting on the pile at a depth  $z$  below the ground surface of a cohesionless soil is given as:

$$p(z) = \frac{\gamma z}{N_\phi} \left\{ s_1 \left( \frac{s_1}{s_2} \right)^{\left( N_\phi^{1/2} \tan \phi + N_\phi - 1 \right)} \times \exp \left( \frac{s_1 - s_2}{s_2} N_\phi \tan \phi \times \tan \left( \frac{\pi}{8} + \frac{\phi}{4} \right) \right) - s_2 \right\} \quad (3.7)$$

For an undrained condition of a saturated cohesive soil  $p(z)$  is given by:

$$p(z) = c \left\{ s_1 \left( 3 \ln \frac{s_1}{s_2} + \frac{s_1 - s_2}{s_2} \tan \frac{\pi}{8} \right) - 2(s_1 - s_2) \right\} + \gamma z (s_1 - s_2) \quad (3.8)$$

where  $s_1$  is the center-to-center distance between reinforcing members in the longitudinal direction;  $s_2$  is the edge-to-edge distance between reinforcing members also in the longitudinal direction;  $\phi$  is the angle of internal friction of the soil;  $c$  is the cohesion intercept;  $\gamma$  is the unit weight of the soil; and  $N_\phi = \tan^2(\pi/4 + \phi/2)$ .

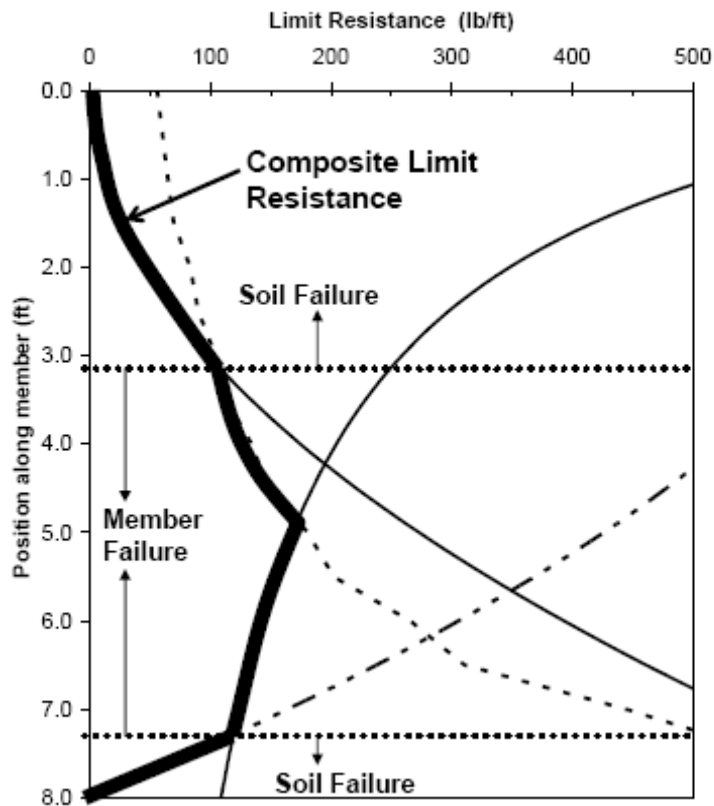

Figure 3.10: Composite limit lateral resistance distribution for recycled plastic reinforcing member (After Loehr & Bowders, 2007).

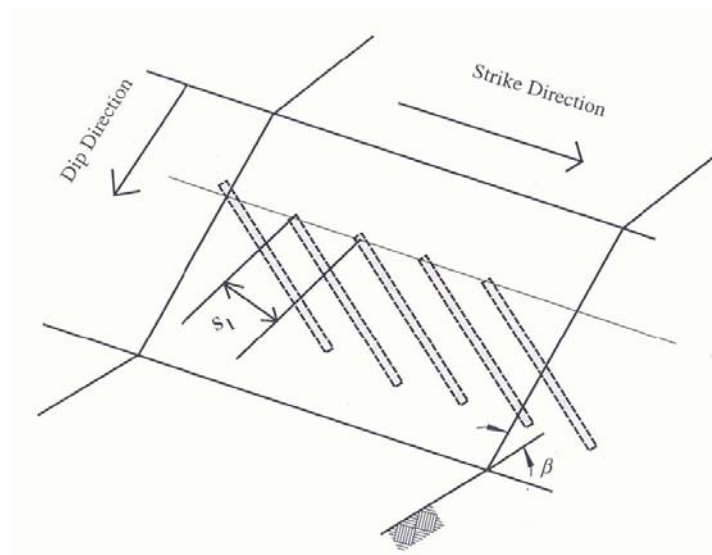

Figure 3.11: Slope reinforced with a single row of reinforcing members spaced equally in the longitudinal (strike) direction (after Liew, 2000).

The limit soil pressure used to calculate the limiting lateral resistance of recycled plastic pins is based on the assumptions of a horizontal ground surface and a vertically installed structural member. Liew (2000) indicated that the member inclination does not have a significant effect on the computed limit soil pressure. Additionally, Loehr et al. (2004) listed several issues associated with this method of analysis that need to be addressed: consideration of the inclination of reinforcing members, possible contributions from axial forces in the members, consideration of group effects, uncertainty in the limiting soil pressure, and uncertainty in the calculated maximum moments.

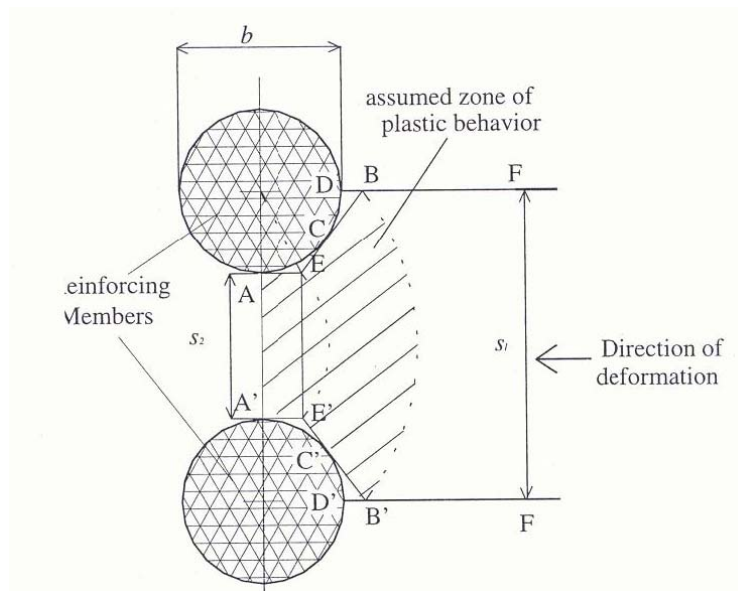

Figure 3.12: Assumed zone of plastic behavior between adjacent piles in a row (after Ito and Matsui, 1975).

### 3.2.4 Parametric Evaluation of the Design and Analysis Method

Liew (2000) used the previously described method to investigate the influence of different variables on the factor of safety of slopes stabilized with reinforcing structural members. A preliminary analysis was conducted using data from a shallow slope failure site near Emma, Missouri (the site is described further in this chapter). Variables investigated include: member size, member orientation (vertical versus perpendicular), and spacing between reinforcing structural members.

Based on field observations, Liew (2000) used the slope geometry and soil properties and conditions shown in Figure 3.13 to conduct his analysis. The slope was analyzed with the observed sliding surface and no presence of pore water pressures ( $u=0$ ) and with assuming the presence of 0.5 ft. upper cohesive soil layer ( $c \approx 50$  psf). By considering the un-reinforced slope condition, it was determined that for  $FS = 1$  the lower soil should have  $\phi' = 20.4^\circ$  and  $c \approx 0$ . Subsequent analysis was conducted to design a slope reinforcement scheme using  $\phi' = 20.4^\circ$ ,  $c \approx 0$ , and  $u=0$ .

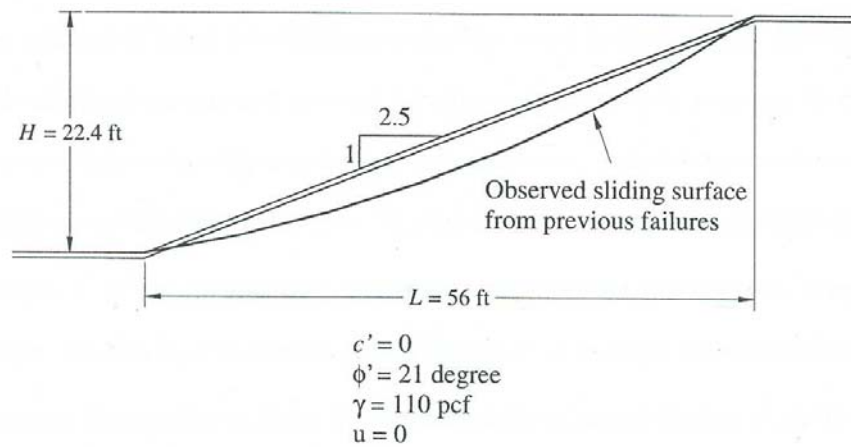

Figure 3.13: Estimated slope geometry and conditions and the observed sliding surface used in the analysis (after Liew, 2000).

Slope stability analysis of reinforced slopes was conducted by Liew (2000) using weak and strong structural members. The weak structural member is a 4"×4"×8' recycled plastic pin with an ultimate shear capacity of 9 kips, an ultimate moment capacity of 0.9 kip-ft, and a modulus of elasticity of 15,000 ksf. A strong structural member is a 6"×6"×8' plastic member with an ultimate shear capacity of 12 kips, an ultimate moment capacity of 3.5 kip-ft, and a modulus of elasticity of 15,000 ksf.

A stability analysis was conducted using reinforcing member spacing  $s_l=1, 3,$  and 6 ft. and  $s_t=1, 3, 4.5, 7,$  and 16 ft., where  $s_l$  is the longitudinal spacing in strike direction and  $s_t$  is the transverse spacing in the dip direction. Reinforcing members were assumed to be installed both vertically and perpendicular to the slope face for both strong and weak

structural members. Tables 3.1 and 3.2 show the computed factor of safety values for the slope reinforced by weak and strong members installed perpendicular to the slope face and vertically for different spacing, respectively. Results of the analysis indicated that structural member reinforcement improved the factor of safety of the slope (compared with  $FS=1$  for the un-reinforced slope) particularly when the transverse spacing is less than 5 ft. The analysis performed by Liew (2000) demonstrated that the factor of safety for the reinforced slopes increases as the spacing in both directions decreases. Inspection of Tables 3.1 and 3.2 shows that the difference in the factor of safety values between weak and strong members is approximately small when the members are closely spaced. There are no differences in the factor of safety values for widely spaced members since the critical slip surfaces become shallow where there is no effect of slope reinforcement.

Figures 3.14 and 3.15 show the critical sliding surfaces for the reinforced slope with longitudinal spacing  $s_l=3$  ft. and various transverse spacing for weak and strong structural members, respectively. The critical slip surface becomes deep (beyond the reinforced zone) when the spacing of the structural members decreases. When the spacing of the structural members becomes sparse, the critical failure surface tends to be shallow passing through the reinforced zone.

Table 3.1: Computed factors of safety for slopes reinforced with 4-in. members placed perpendicular to the face of the slope (after Liew, 2000).

Member	Longitudinal Spacing, $s_l$ (ft.)	Transverse Spacing, $s_t$ (ft.)				
		1	3	4.5	7	16
Weak	1	1.39	1.31	1.27	1.23	1.14
	3	1.29	1.20	1.16	1.11	1.05
	6	1.22	1.12	1.08	1.05	1.02
Strong	1	1.39	1.36	1.31	1.27	1.14
	3	1.31	1.22	1.16	1.11	1.10
	6	1.24	1.12	1.08	1.05	1.02

Table 3.2: Computed factors of safety for slopes reinforced with 4-in. members placed vertically (after Liew, 2000).

Member	Longitudinal Spacing, $s_l$ (ft.)	Transverse Spacing, $s_t$ (ft.)				
		1	3	4.5	7	16
Weak	1	1.43	1.33	1.27	1.22	1.12
	3	1.30	1.19	1.15	1.12	1.06
	6	1.22	1.13	1.08	1.05	1.02
Strong	1	1.43	1.38	1.31	1.25	1.14
	3	1.32	1.20	1.17	1.11	1.04
	6	1.23	1.12	1.08	1.05	1.02

The Liew (2000) analysis resulted in a slightly higher factor of safety for slopes stabilized with vertical structural members compared with perpendicular members at similar spacing. This result was attributed to using slightly different limiting resistance distributions for each scenario. The axial component of the resistance, provided by reinforcing structural members, was neglected by the Liew (2000) analysis.

Using the same analysis, Liew (2000) performed a parametric study to investigate the effects of slope geometry (steepness) and structural member characteristics (capacity, inclination, length, and cross-section) on the factor of safety of slopes stabilized by reinforcing structural members. The results of the study are consistent with what was presented in this section in relation to the structural member capacity. The influence of slope geometry is described below.

Slope geometries of 1.5H:1V, 2.5H:1V, and 3.5H:1V were investigated to determine the influence of slope inclination on the factor of safety. The analysis was conducted on slope geometries, soil properties, and conditions shown in Figure 3.16. Soil properties were back-calculated assuming each un-reinforced slope has a factor of safety  $FS=1$ . Results of the parametric study are presented in Table 3.3. The results indicate that the factor of safety generally increases when the transverse spacing decreases for a given longitudinal spacing. In addition, the results suggest that slope reinforcement with structural members significantly improves the factor of safety for steeper slopes at a higher degree compared with flatter slopes with reinforcing members installed at the same spacing.

The orientation of reinforcing structural members is preferred to be in a staggered grid, as indicated in the study by Loehr and Bowders (2007). This method is claimed to produce better load transfer among members in the form of group action that will result in improved sliding resistance (Chen and Poulos, 1997).

Table 3.3: Computed factors of safety for slopes reinforced with 4-in. members placed perpendicular to slope (after Liew, 2000).

Slope Inclination	Longitudinal Spacing, $s_l$ (ft.)	Transverse Spacing, $s_t$ (ft.)					
		1	3	4.5	5	7	16
1.5H: 1V	1	1.71	1.53	1.45	-	1.41	1.22
	3	1.47	1.19	1.13	-	1.08	1.03
	6	1.27	1.08	1.05	-	1.03	1.01
2.5H: 1V	1	1.39	1.31	1.27	-	1.23	1.14
	3	1.29	1.20	1.16	-	1.11	1.05
	6	1.22	1.12	1.08	-	1.05	1.02
3.5H: 1V	1	1.26	1.24	-	1.20	1.16	1.10
	3	1.22	1.15	-	1.11	1.09	1.05
	6	1.17	1.10	-	1.07	1.06	1.03

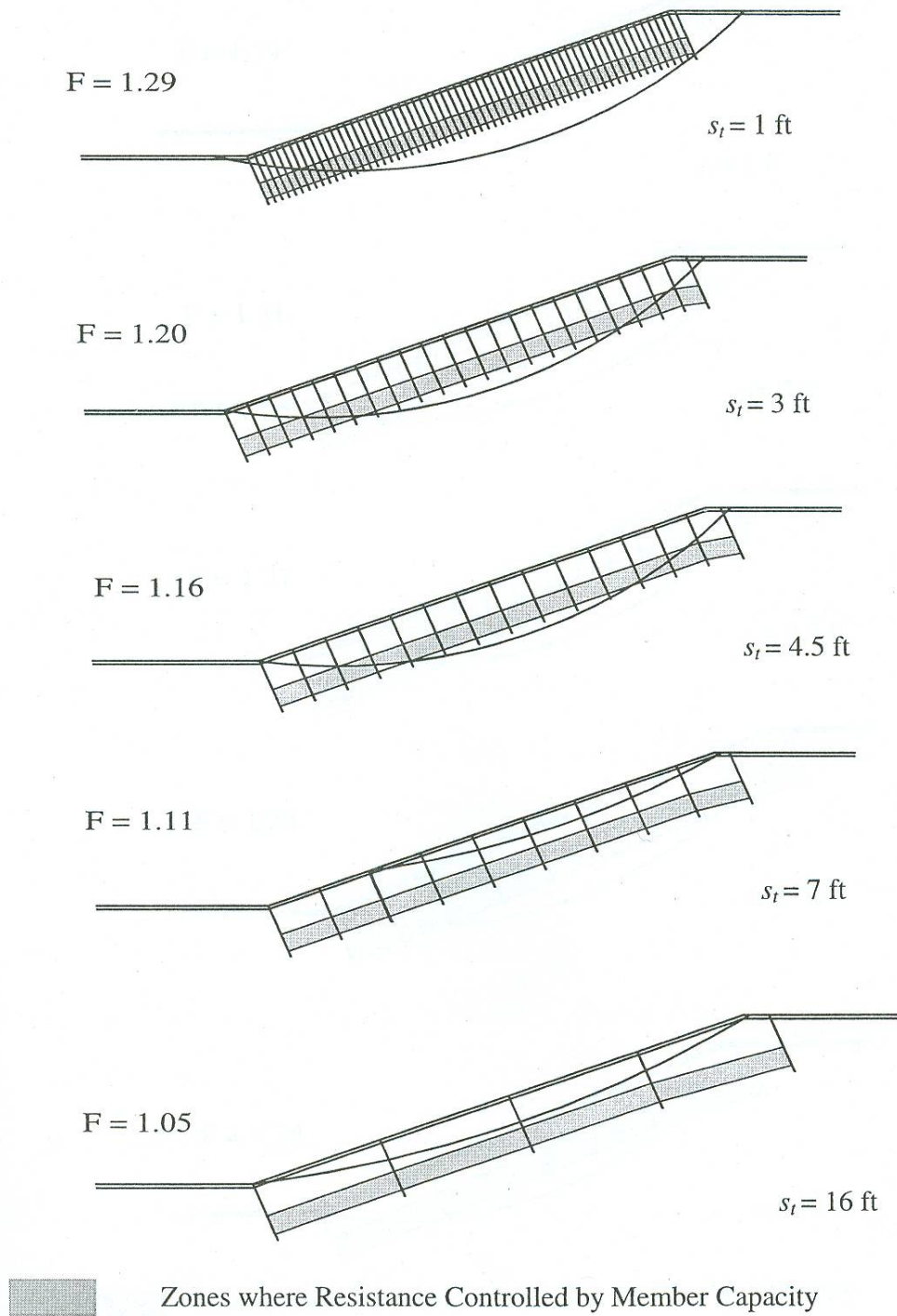

Figure 3.14: Critical sliding surfaces for a slope reinforced with 4-in. weak members placed perpendicular to the slope face with longitudinal spacing  $s_l=3$  ft.

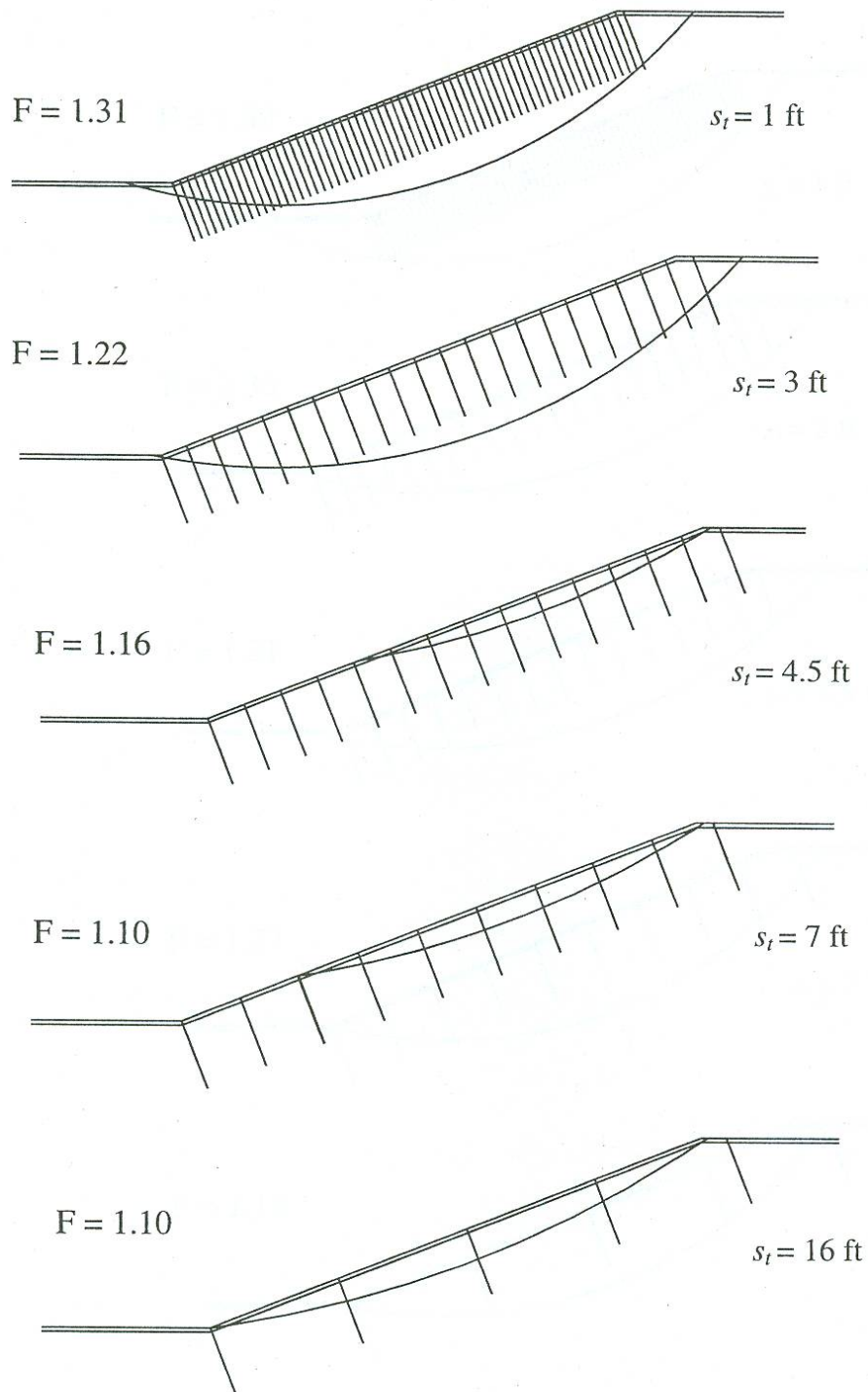
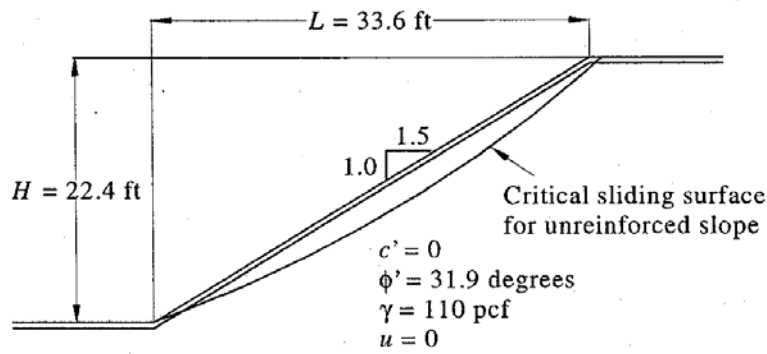
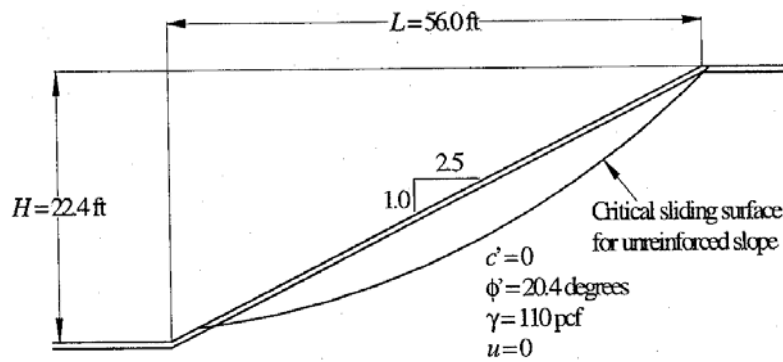

Figure 3.15: Critical sliding surfaces for a slope reinforced with 4-in. strong members placed perpendicular to the slope face with longitudinal spacing  $s_t=3$  ft.



(a) Steep slope



(b) Intermediate slope

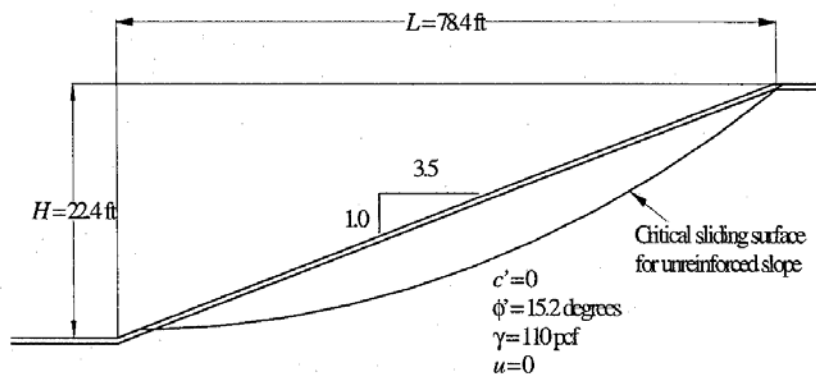

(c) Flat slope

Figure 3.16: Slope geometries and soil and site conditions assumed in the parametric study (after Liew 2000).

### 3.3 Materials

Investigating the material properties of the structural members used for slope stabilization is important since structural failure of these members increases the potential for slope failure. Various materials are used to produce structural members for use in slope stability. The literature search and review of this study indicated that the following materials are used in slope stability of shallow slope failures using conventional installation methods:

1. Steel and galvanized steel (pipe piles)
2. Concrete (precast concrete pile)
3. Wood (treated and untreated wood piles and timber posts)
4. Recycled plastic (plastic lumber)

For launched soil nails, steel is used to manufacture non-galvanized rods and hollow bar nails. Earth anchors are made of different materials, depending on the application and soil environment. Anchors are made of aluminum alloy, aluminum bronze alloy, or cast iron. Wire ropes are made of galvanized steel, plastic impregnated steel, or stainless steel. Rods are manufactured of standard steel, galvanized steel, or stainless steel.

Based on the research in this study, the research team believes that reinforcing structural members made of plastic lumber and wood materials have the potential to be implemented in the stability of surficial slope failures because of construction and cost effectiveness. Personal communications (Spancrete 2007) indicated that a small size structural member (e.g., a square 4 in.×4in.×8ft.) made of precast concrete is considered a special order member that is not available. Such a member will cost approximately \$75 and will be relatively heavy and difficult to handle compared with wooden and plastic members of the same size. Therefore, no further description is presented on concrete members.

Characteristics of the materials most commonly used in producing structural members stabilizing surficial slope failures are described below.

#### 3.3.1 *Recycled Plastic Members*

Plastic lumber is produced from recycled plastic products (low and high density polyethylene) and some types of plastic lumber are manufactured to withstand structural loads (for structural applications). When compared with structural members made of concrete and steel, plastic lumber has lower strength and higher ductility and creep. Plastic lumber can be treated to resist ultraviolet light, which makes it less susceptible to degradation. Generally, high density polyethylene is highly resistant to acids and chemicals.

The engineering properties of plastic lumber vary depending on the material used to produce the lumber; manufacturers usually provide the engineering properties. Table 3.4

summarizes the standard test methods used to characterize the engineering properties of plastic lumber.

Table 3.4: ASTM standard test methods used by the plastics industry to evaluate the material properties of plastic lumber.

Standard Test Designation	Standard Test Title
ASTM D2394-05	Standard Methods for Simulated Service Testing of Wood and Wood-Base Finish Flooring
ASTM D6108-03	Standard Test Method for Compressive Properties of Plastic Lumber and Shapes
ASTM D6109-05	Standard Test Methods for Flexural Properties of Unreinforced and Reinforced Plastic Lumber and Related Products
ASTM D6111-03	Standard Test Method for Bulk Density and Specific Gravity of Plastic Lumber and Shapes by Displacement
ASTM D6341-98(2005)	Standard Test Method for Determination of the Linear Coefficient of Thermal Expansion of Plastic Lumber and Plastic Lumber Shapes Between -30 and 140°F (-34.4 and 60°C)
ASTM D695-02a	Standard Test Method for Compressive Properties of Rigid Plastics
ASTM D790-03	Standard Test Methods for Flexural Properties of Unreinforced and Reinforced Plastics and Electrical Insulating Materials
C1028-06	Standard Test Method for Determining the Static Coefficient of Friction of Ceramic Tile and Other Like Surfaces by the Horizontal Dynamometer Pull-Meter Method

Engineering material properties of plastic lumber are presented as obtained from selected manufacturers' data. As an example, Resco Plastics, Inc. manufactures plastic lumber that can be used for slope stabilization. The following is a description of the Resco plastic lumber properties as obtained from standard laboratory tests:

Flexural strength tests were conducted on four simply supported beam specimens according to the modified third-point load. The beam dimensions are 2 in. × 6 in. × 26 in. with a 24 in. supported span. The maximum applied load that caused failure ranged from 3,560 to 3,770 lbs. with corresponding crosshead deflection of  $2\frac{3}{16}$  and  $2\frac{1}{4}$  in. The average maximum fiber stress for the four tested specimens was 3,650 psi, as shown in Table 3.5.

Direct shear tests were conducted on two 4 in. × 1 in. cylindrical specimens. These specimens were reduced from 6 in. × 2 in. members and were tested along the actual axis

of the member. The average shear strength obtained is 887 psi. A third specimen was tested along the width of the original member with shear strength of 1,255 psi.

Compression tests were performed on five 2 in.× 1 in.× 1 in. specimens in accordance with ASTM D695. The compressive strength ranged between 3,410 and 4,420 psi with an average of 3,896 psi.

A friction test in accordance with ASTM C 1028-89 was conducted to determine the static coefficient of the friction of a plastic platform made of plastic planks installed side by side. Four different surface conditions were selected: wet as received, wet prepared, dry as received, and dry prepared. The test results are presented in Table 3.5.

Table 3.5: Plastic lumber properties from standard laboratory tests (Resco Plastics, Inc., 2007).

Test	ASTM Standard Designation	Material Property	Average Value
Flexural strength	ASTM D790	Maximum fiber stress	3,650 psi
Shear strength	-	Shear strength (along the actual axis)	887 psi
Shear strength	-	Shear strength, along the width of original member	1,255 psi
Static coefficient of friction – dry surface as received	ASTM C 1028-89	Coefficient of friction	0.69
Static coefficient of friction – dry prepared surface	ASTM C 1028-89	Coefficient of friction	0.72
Static coefficient of friction – wet surface as received	ASTM C 1028-89	Coefficient of friction	0.50
Static coefficient of friction – wet prepared surface	ASTM C 1028-89	Coefficient of friction	0.48

In addition, the engineering properties of plastic lumber from Bedford Technology® were obtained and are summarized in Table 3.6. It should be noted that an ultraviolet stabilizer was incorporated into this lumber during manufacturing to provide protection against UV light degradation.

For slope stability applications, plastic lumber strength and stiffness and resistance to installation stresses are important, as shown in Figure 3.17 (Loehr and Bowders 2007). In addition, Loehr et al. (2000) conducted tension, compression, shear, and bending tests on plastic lumber. The results are summarized in Table 3.7.

Table 3.6: Average values of standard test results on Select™ Lumber provided by Bedford Technology®.

Test	ASTM Standard Designation	Value
Specific gravity	ASTM D6111-97	0.861
Flexural strength	ASTM D6109-97	1,355 psi
Flexural modulus	ASTM D6109-97	95,939 psi
Compression strength	ASTM D6108-97	1,420 psi
Compression modulus	ASTM D6108-97	51,000 psi
Moisture absorption		0.06% (by weight)
Thermal expansion	ASTM D6341-98	0.000055 in/in/°F
Static coefficient of friction – dry	ASTM D2394-83(99)	0.48
Static coefficient of friction – wet	ASTM D2394-83(99)	0.40
Sliding coefficient of friction – dry	ASTM D2394-83(99)	0.22
Sliding coefficient of friction – wet	ASTM D2394-83(99)	0.43

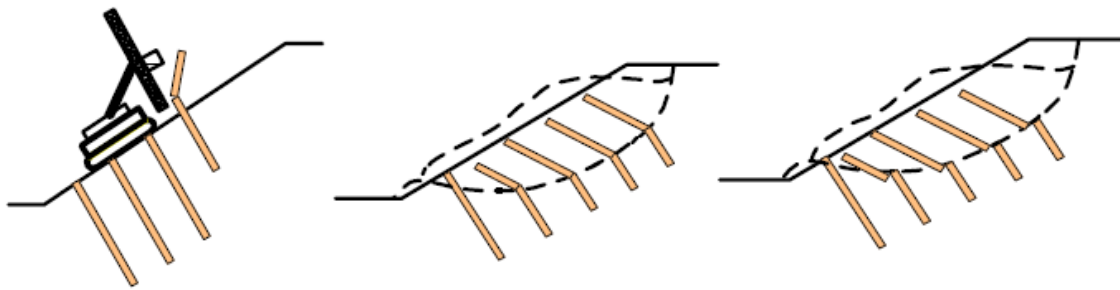

(a) Installation durability      (b) Bending and creep failure      (c) Shear failure

Figure 3.17: Three potential modes of failure for reinforcing members in slope stabilization applications (Loehr and Bowders, 2007).

Table 3.7: Material property test results on recycled plastic subjected to various environmental conditions (after Loehr et al. 2000).

Exposure Environment	Tension Test ksi (MPa)		Compression Test ksi (MPa)		Shear Test ksi (MPa)	Bending Test (kN-m)
	Young's Modulus	Peak Stress	Young's Modulus	Peak Stress	Peak Stress	Peak Moment
No exposure	906	13	794	21	8.7	1.5
Acid (pH=5)	924	12	877	18	-	-
UV	822	9	642	15	-	-
Water	925	12	680	18	-	-
Freeze/thaw	791	11	702	19	-	-

### 3.3.2 Wood Lumber

The engineering properties of wood lumber also are reported in this study and have a wide range of variability dependent on manufacturing. Table 3.8 presents the engineering properties of different grades of wood lumber. Table 3.9 shows the results of a comparative study performed by the US Army Corps of Engineers, showing the effects of treatment type on the properties of wood lumber.

Table 3.8: Engineering properties of wood lumber (American Forest & Paper Association, 2007).

Grade Designation	Size Class	Mechanical Properties, psi						
		Bending	Tension Parallel to Grain	Shear Parallel to Grain	Compression Perpendicular to Grain	Compression Parallel to Grain	Modulus of Elasticity	Minimum Modulus of Elasticity
Select Structural		1,250	575	135	350	1,200	1,200,000	440,000
No. 1		775	350	135	350	1,000	1,100,000	400,000
No. 2	2 in. & wider	575	275	135	350	825	1,100,000	400,000
No. 3		350	150	135	350	475	900,000	330,000
Stud	2 in. & wider	450	200	135	350	525	900,000	330,000
Construction		675	300	135	350	1,050	1,000,000	370,000
Standard	2 to 4 in. wide	375	175	135	350	850	900,000	330,000
Utility		175	75	135	350	550	800,000	290,000

Table 3.9: Engineering properties of treated wood lumber (US Army Corps of Engineers, Civil Engineering Laboratory).

	Type of Treatment	Modulus of Rupture (psi)	Modulus of Elasticity in Flexure (10×6 psi)	Average Absorb Energy in Flexure (in.-lb/cu in.)	Compression Strength, F <sub>c</sub> (psi)
FIR	Untreated	8,394	1.922	6.338	3,346
	Creosote	6,862	1.584	4.202	N/A
	ACA dual	6,111	1.537	3.059	2,714
	CCA dual	3,844	1.171	3.364	2,333
	ACA	5,620	1.416	2.078	2,462
PINE	Untreated	8,007	1.942	5.240	N/A
	Creosote	5,950	N/A	N/A	N/A
	ACA dual	4,725	1.568	2.829	N/A
	CCA dual	4,167	1.441	2.413	N/A
	ACA	5,534	1.538	N/A	N/A
	CCA	5,410	N/A	N/A	N/A

N/A is due to a large spread in measured data for a small number of samples.

Dual Treatment Types include both air-dried and kiln-dried specimens.

(ACA) Ammonical Copper Arsenate is generally applied to Douglas Fir.

(CCA) Chromated Copper Arsenate is generally applied to Pine.

### 3.3.3 Steel

Two common types of steel are used to manufacture steel pipes: SAE 1008 and ASTM A500. The engineering properties are presented in Tables 3.10 and 3.11.

Table 3.10: Engineering properties of SAE 1008 Steel

Type of Plating	Commercial Name	Hardness	Tensile (MPa)	Yield (MPa)	Elongation in 50mm	Density g/cm <sup>3</sup>
Steel	Carbon Steel	95 HRB	340	290 min	20%	7.7
Tinned	Carbon Steel	95 HRB	340	290 min	20%	7.7
Nickel	Carbon Steel	95 HRB	340	290 min	20%	7.7
Copper	Carbon Steel	95 HRB	340	290 min	20%	7.7
Bright Zinc	Carbon Steel	95 HRB	340	290 min	20%	7.7
Galvanize	Carbon Steel	95 HRB	340	290 min	20%	7.7
Stainless	Cr-Ni-Mo Stainless Steel	95 max	515	205	40%	8.0

Mechanical Properties for Carbon Steel, Cold Drawn @ HO4  
Density at 20 Degrees Centigrade

Table 3.11: Mechanical properties for cold formed tubing (ASTM A500 steel)

Grade	Minimum Strength Requirements			
	Tensile	Yield (round)	Yield (shaped)	Elongation
	MPa (ksi)	MPa (ksi)	MPa (ksi)	%
A	310 (45)	228 (33)	269 (39)	25
B	400 (58)	290 (42)	317 (46)	23
C	427 (62)	317 (46)	345 (50)	21
D	400 (58)	250 (36)	250 (36)	23

### 3.4 Construction

One of the advantages of using short structural members (relatively small size and light weight), such as plastic lumber in stabilizing of a shallow slope, is the relative ease of installation using small size equipment. These members can be driven into the ground using percussion or impact hammers (hydraulic or pneumatic). Important factors to consider when selecting the installation equipment include:

- (1) Damage inflicted on the structural member. Incompatibility between the driving hammer power/size and the size and strength of the structural members can produce excessive stresses during installation that may damage or break the structural members. This can be evident when stiff clay or dense sand is encountered during driving. Plastic lumber and wood posts are more likely to be affected compared with steel pipe piles.
- (2) Availability of the alignment mechanism between the driving hammer and the member. It is crucial that the driving hammer and the member to be driven are aligned according to the inclination required. A misaligned situation can impede production and damage the structural members.
- (3) Weight and maneuverability of the equipment on slopes. The weight of the equipment is important, particularly when heavy machines are used on wet slopes. This can create rutting and the machine may become stuck. Moreover, the maneuverability of the machine becomes difficult.
- (4) Production rate and cost. The production rate depends on many factors, such as the member type and strength and the soil type. Machines with a light weight, alignment mechanism and high maneuverability are expected to have a good production rate. This in turn may reduce the cost of slope stabilization.

Loehr et al. (2000) and Loehr and Bowders (2007) presented a comprehensive analysis of the reliability and performance of construction methods and the equipment used for surficial slope stabilization using plastic, steel pipes, and wooden structural members. Table 3.12 summarizes their study, in which different equipment types were used to stabilize five surficial slope failures in Missouri. The equipment is depicted in Figure 3.18. Based on this study, Loehr and Bowders (2007) reached the following conclusion:

- Different equipment types were used successfully to install structural members (recycled plastic pins, steel pipes, and timber posts) of relatively small size. The equipment comprised some form of a percussion or impact hammering device to install the members in the ground.
- The average penetration rates (set up time not included) observed were about 6 ft./min. and peak installation rates exceeded 140 members per day for a single piece of equipment. The approximate average penetration rates are 4 ft./min. (~100 members/day). Figure 3.19 shows the installation performance in terms of the penetration rates.

Table 3.12: Comparison of different equipment performance used to install structural members to stabilize shallow slope failures in Missouri.

Site	Construction Equipment	Structural member type and performance	Performance Comments
Emma – Sections S1 & S2	Case 580 backhoe with Okada OKB 305 hydraulic hammer	<ul style="list-style-type: none"> <li>Recycled plastic pins used</li> <li>High percentage of damage (22 out of 45 broken)</li> </ul>	<ul style="list-style-type: none"> <li>No hammer/ member alignment mechanism</li> <li>Difficult to operate and maneuver on slope</li> </ul>
	Davey-Kent DK100B track-mounted hydraulic drilling rig	<ul style="list-style-type: none"> <li>Recycled plastic pins</li> <li>No reported damage</li> </ul>	<ul style="list-style-type: none"> <li>Good hammer/member alignment</li> <li>Good maneuver on slope</li> </ul>
Emma – Section S3	Ingersoll Rand ECM350 track-mounted pneumatic hammer drilling rig		<ul style="list-style-type: none"> <li>Exceptional equipment performance and rapid installation</li> <li>Extendable boom allowed covering large area of slope without moving the chassis</li> </ul>
	Daken Farm King drop weight device mounted on skid-steer loader (used to drive fence or guard-rail posts)	<ul style="list-style-type: none"> <li>199 recycled plastic pins installed</li> <li>Three pressure treated timber posts showed slight brooming</li> </ul>	<ul style="list-style-type: none"> <li>Exceptional equipment performance and rapid installation</li> </ul>
I435-Wornall Road	Davey-Kent DK100B track-mounted hydraulic rig	<ul style="list-style-type: none"> <li>Used to install 30 plastic recycled pins</li> </ul>	<ul style="list-style-type: none"> <li>Site was re-graded to its original slope before the installation of reinforcing members started.</li> <li>Cable and pulley system was used to assist both rigs perform maneuvering on slope and to prevent them from tipping over on the steep slope</li> <li>Heavy equipment caused severe rutting on the wet slope</li> </ul>
	Ingersoll Rand (IR) CM150 pneumatic rock drilling rig	<ul style="list-style-type: none"> <li>Used to install total of 590 members (mostly plastic pins)</li> <li>3 pipe piles were installed (diameter=3.5 in.)</li> </ul>	<ul style="list-style-type: none"> <li>Low penetration rates on stiff compacted clay shale fill</li> <li>Penetration was stopped when rate &lt; 3in./min. to prevent member damage</li> </ul>
I435-Holmes Road	Ingersoll Rand (IR) CM150 pneumatic rock drilling rig	<ul style="list-style-type: none"> <li>Used to install 256 galvanized steel pipes (diameter=3.5 in.)</li> <li>6 recycled plastic pins were installed</li> </ul>	<ul style="list-style-type: none"> <li>Site was not re-graded to its original slope prior to installation of reinforcing members</li> <li>Pipes that did not plug during installation were filled with bagged cement grout</li> <li>Average penetration for steel pipes = 5 ft./min.</li> <li>Average penetration for plastic pins = 4.6 ft./min.</li> </ul>
US36-Stewartville Site	Ingersoll Rand (IR) CM150 pneumatic rock drilling rig	<ul style="list-style-type: none"> <li>Used to install 360 recycled plastic pins</li> </ul>	<ul style="list-style-type: none"> <li>Failure area was regarded to its original slope</li> <li>Defected plastic members were split and shattered during installation. Members were inspected for defects and non-defected members were installed without problems</li> </ul>
US54-Fulton Site	Ingersoll Rand ECM350 track-mounted pneumatic hammer drilling rig	<ul style="list-style-type: none"> <li>Used to install 373 recycled plastic pins</li> <li>Used to install 3 landscaping timber posts (diameter – 3 in.)</li> </ul>	<ul style="list-style-type: none"> <li>Failure area was regarded to its original slope</li> <li>Good maneuvering on this flat slope (3.2H:1V)</li> <li>No significant difference in the drivability of the recycled plastic and timber members</li> <li>Extendable boom allowed covering large area of slope</li> </ul>



(a) Backhoe mounted hammer



(b) Davey-Kent DK100B track-mounted hydraulic rig



(c) Ingersoll Rand CM150 track-mounted pneumatic rig



(d) Ingersoll Rand ECM350 pneumatic hammer drill (background) and drop-weight hammer rig (foreground)



(e) Davey-Kent DK100B track-mounted hydraulic rig



(f) Ingersoll Rand CM150 track-mounted pneumatic rig

Figure 3.18: Equipment used to install plastic pins, steel pipes, and wooden posts at different sites of surficial slopes failures in Missouri (after Loehr and Bowders, 2007).

- There was no significant difference between the average penetration rates of steel pipe piles (at 5 ft./min.) and recycled plastic pins (at 4.5 ft./min.), indicating that reinforcing member stiffness does not have a significant influence on field installation rates.
- Using steel pipe piles as reinforcing members did not provide significant benefits over recycled plastic pins in terms of constructability. Problems cited were related to (a) the heavy weight of steel pipes of about 70 lb./ 8-ft. member versus 45 lb./8-ft. member of plastic pins; and (b) difficulties in cutting steel pipes when penetration reached refusal. However, Loehr and Bowders (2007) did not provide any comparison in terms of long-term performance, as no data are available.

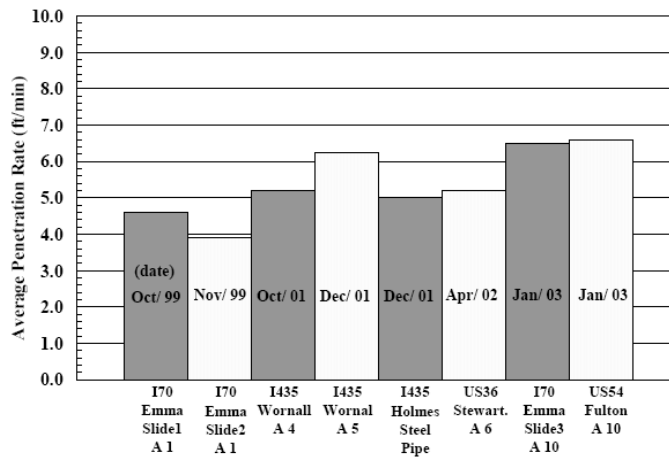

(a) Average penetration rates

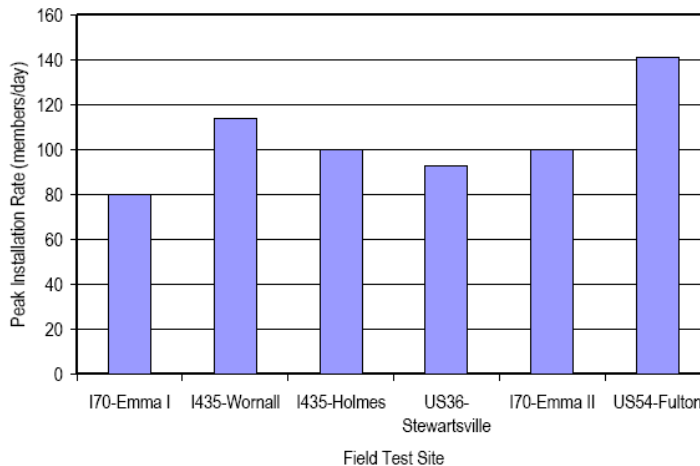

(b) Peak installation rates using one installation rig

Figure 3.19: Performance of installation structural members used in the stability of surficial slope failure (after Loehr and Bowders 2007).

### 3.5 Case Histories

There is little detailed information on the stabilization of shallow slope failures with structural members; however, a detailed and well-documented case history of using vertical members (recycled plastic pins) to stabilize shallow slope failures was reported by Loehr and Bowders (2007). The slope stabilization project was conducted along I-70 near the city of Emma, Missouri. The slope consists of an approximately 22 ft. high embankment with slopes varying from 2.5:1 to 2.2:1 (H:V). The embankment material consists of lean and fat clay with scattered gravel, cobbles, and construction rubble of asphalt and concrete. The embankment has shown recurring surficial slope failure in four areas, S1, S2, S3, and S4, shown in Figure 3.20. Attempts to correct these surficial failures using different techniques did not succeed. The stabilization methods used were regrading, dumping concrete rubble over the embankment crest, and replacing the soil near the slope toe with rubble.

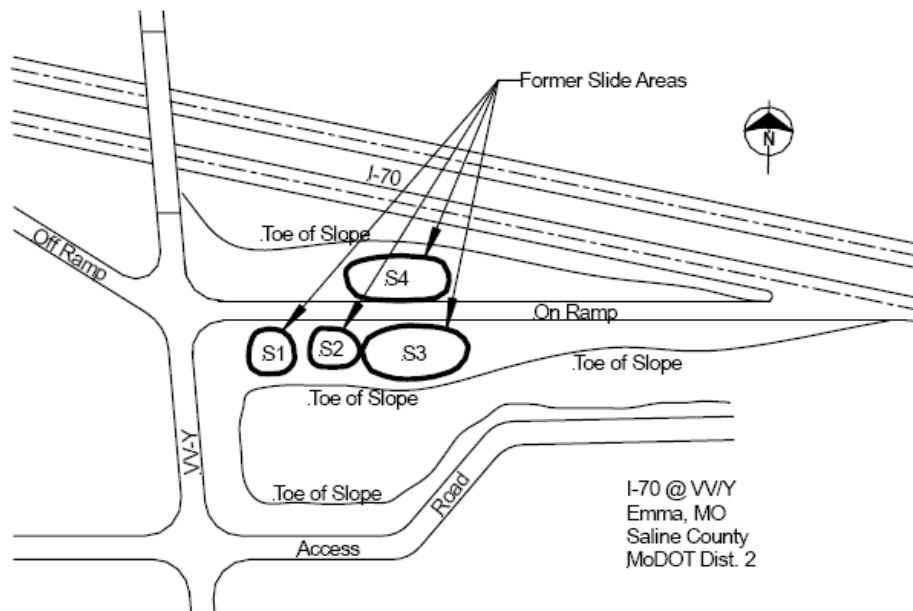

Figure 3.20: Surficial slope failures (S1, S2, S3, and S4) along I-70 embankment near Emma, Missouri (Loehr and Bowders, 2007).

Comprehensive subsurface sampling and field and laboratory testing were conducted at this site, which included 11 borings up to 33 ft. deep with Shelby tube sampling and standard penetration test (SPT). Laboratory tests included tests to classify the soil, triaxial test, and direct shear test.

The stabilization of slope failures at this site was conducted to assess the potential of using recycled plastic pins in correcting surficial slope instabilities. To stabilize the failure areas S1 and S2, analysis was conducted based on back-calculated soil strength parameters to develop a stability design in the first phase of the project before field and laboratory testing programs were conducted. Therefore, assumptions were made to

perform the analysis with effective cohesion  $c'=0$ , homogenous soil conditions, and drained conditions. In addition, pore water pressure was assumed to be negligible at the site. Based on these assumptions, an effective angle of internal friction was calculated as  $\phi' = 22^\circ$ . Stabilization schemes were proposed and the corresponding factors of safety were calculated. Table 3.13 summarizes the reinforcement configuration for the failed zones S1 and S2. The slope reinforcement configuration used to stabilize areas S1 and S2 is shown in Figure 3.21. The stabilization scheme consists of using a 3 ft.  $\times$  3 ft. staggered grid in which plastic pins are installed perpendicular to the slope in area S1 and vertically in area S2. The factor of safety for both stability schemes was estimated as 1.2.

Table 3.13: Factor of safety from slope stability analysis using 4 in. square plastic lumber.

Longitudinal Spacing (ft)	Transverse Spacing (ft)	Factor of Safety
6	6	1.05
3	3	1.43

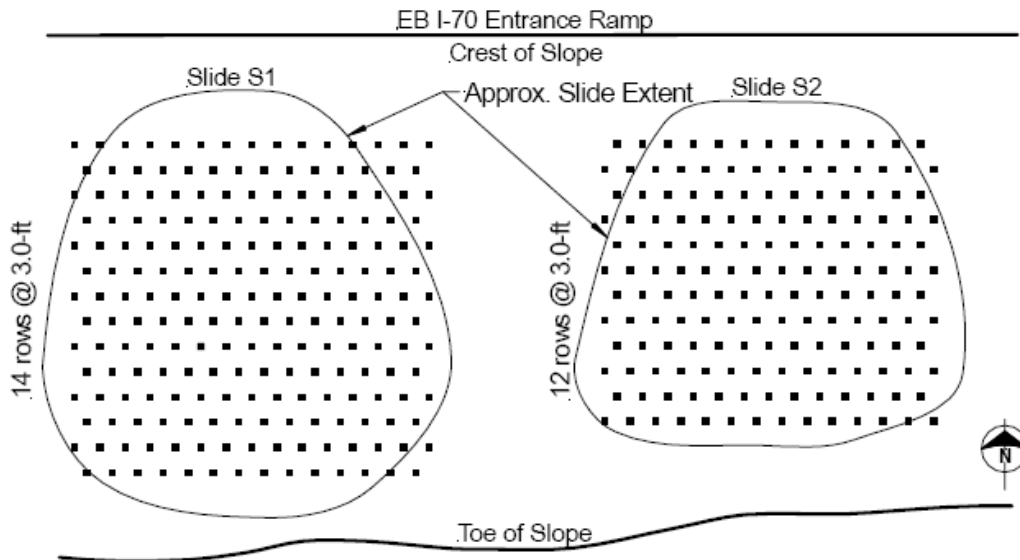

Figure 3.21: Plan view of slide areas S1 and S2 at the I-70 Emma site showing a selected layout of reinforcing members (Loehr and Bowders, 2007).

Failure areas S1 and S2 were stabilized in November 1999 while failure areas S3 and S4 were regraded to the original slope and established as control sections. Monitoring of the slope showed that areas S1 and S2 stabilized with 3 ft.  $\times$  3 ft. square plastic pins performed very well while control sections S3 and S4 failed in spring 2001. Additional stabilization was carried out for failure area S3 using more widely spaced patterns, as presented in Figure 3.22. Slide area S4 was regraded again to its original slope and maintained as a control section.

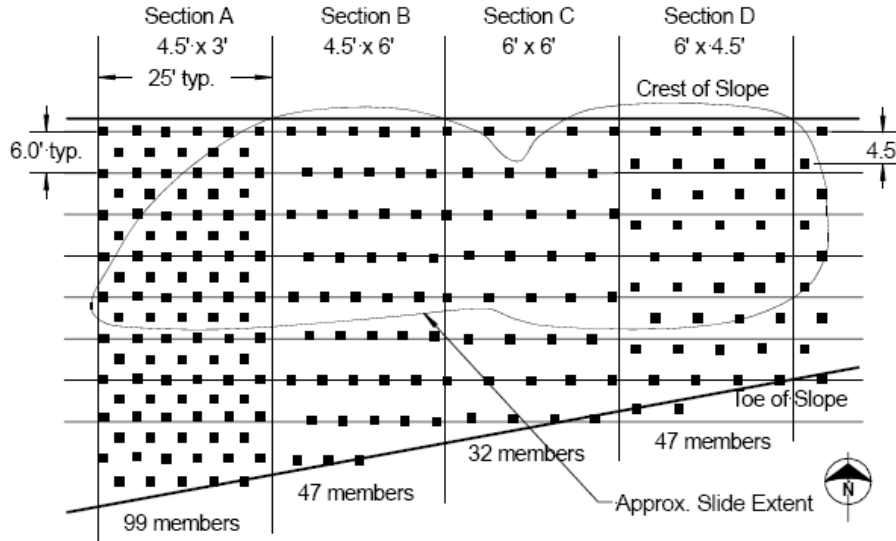

Figure 3.22: Plan view of selected stabilization schemes for slide area S3 at the I-70 Emma test site (Loehr and Bowders, 2007).

Slide area S3 was divided into four sections with different spacing patterns, as presented in Table 3.14. A stability analysis was conducted assuming two stability conditions: condition A using back calculated strength parameters, and condition B assuming a two layer system with water perched within the upper layer, as depicted in Figure 3.23. The piezometric line for the upper layer was assumed to be at ground surface. Analysis was conducted without any reinforcement and yielded a factor of safety  $FS=1$  for both conditions.

The results of the stability analysis are presented in Table 3.14. As shown in Table 3.14, the factor of safety is the lowest when plastic pin spacing was 6 ft.  $\times$  6 ft. in both conditions A and B with values of  $FS=1.06$  and  $FS=1.01$ , respectively.

Layer No.	Description	Unit Weight (pcf)	Shear Strength Parameters	
			$c'$ (psf)	$\phi'$ (degree)
1	Soft clay	113	95	15
2	Stiff clay	126	310	22

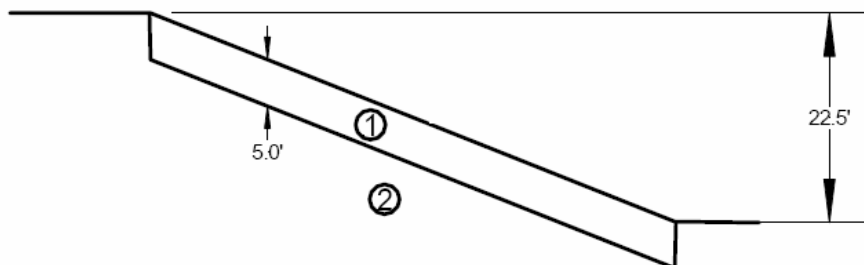

Figure 3.23: Slope section assumed in stability condition B (after Loehr and Bowders, 2007).

Table 3.14: Estimated factors of safety for Sections A through D in slide area S3 and slide areas S1 and S2 at the I-70 Emma test site (after Loehr and Bowers, 2007).

Reinforcement Spacing (ft)	Slope Section	Factor of Safety (FS)	
		Stability Condition A	Stability Condition B
3.0 L × 3.0 T	S1, S2	1.20	1.21
4.5 L × 3.0 T	A (S3)	1.16	1.10
4.5 L × 6.0 T	B (S3)	1.10	1.03
6.0 L × 4.5 T	D (S3)	1.08	1.02
6.0 L × 6.0 T	C (S3)	1.06	1.01

The slide areas were instrumented with inclinometers, standpipe piezometers, and moisture sensors. Instrumented plastic pins also were installed in these areas. In addition, weather data were collected from the National Climate Data Center about four miles from the project. A field monitoring program was executed from installation (November 1999) through December 2002 for areas S1, S2, and S3, and from installation (January 2003) through January 2005 for areas S3 and S4.

Field performance data for slide areas S1, S2, and S3 from November 1999 to December 2002 were collected and analyzed. The data suggests that significant initial stresses and moments were developed in the members due to installation. The distribution of axial stresses in one of the instrumented members is presented in Figure 3.24. The distribution of bending moments in another instrumented member is depicted in Figure 3.25. As shown in both figures, the distribution of axial stresses and bending moments is parabolic, with maximum values near the mid-member point and negligible values at the member ends.

One important observation from the collected field data is that the members installed perpendicular to the slope face experienced greater incremental axial stresses and bending moments when compared with members that were installed vertically.

Field performance data for slide area S3 from January 2003 to January 2005 were collected and analyzed. The control area S4 failed during summer 2004 during an extended period of well above average rainfall. Increased deformation was observed in the stabilized sections during that period. A failure occurred in Sections B and C of area S3 between November 2004 and January 2005, as shown in Figure 3.26. The failure was about 25 ~ 30 ft. wide and confined to the upper part of the slope. The failure did not extend into Section A, which is heavily reinforced (spacing 4.5 ft. × 3 ft.). Field excavation work was conducted at the failed section to investigate the cause of failure and to identify the failure depth. It was not possible to identify the failure surface depth because it was not apparent. Field investigation showed that the recovered plastic pins were broken, indicating structural failure of these members.

Field data for slide areas S1 and S2 from January 2003 to January 2005 indicated that these stabilized areas performed well and no failures were observed. Moreover, field observations indicated that creep of the recycled plastic members may have influenced the performance of the stabilized slopes.

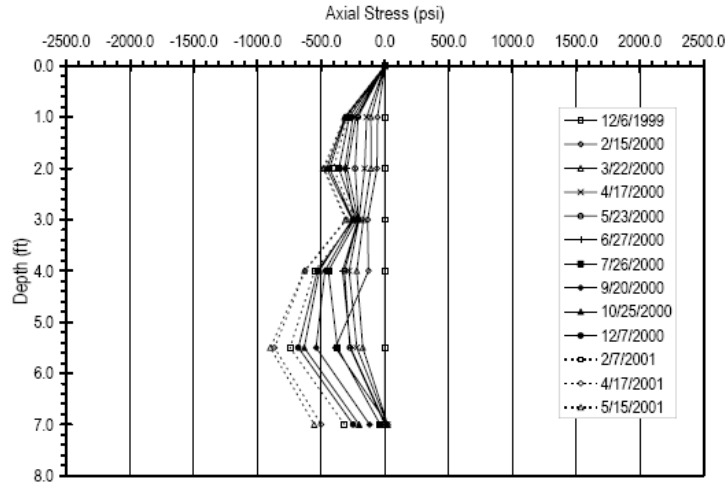

Figure 3.24: Measured incremental axial stress in instrumented member IMG in slide area S1 at I-70 Emma site during Phase I (Loehr and Bowders, 2007).

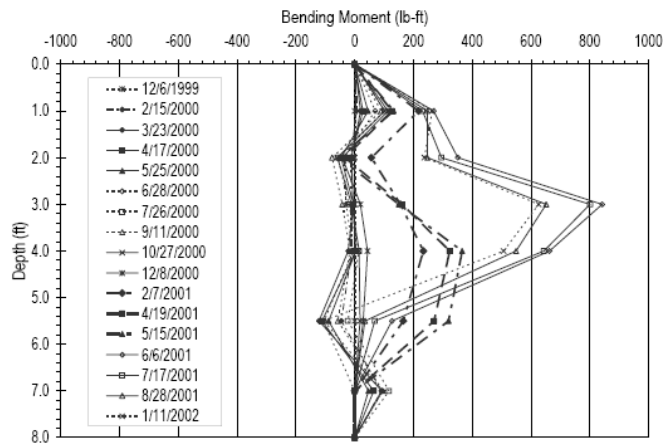

Figure 3.25: Measured bending moments in instrumented member IM-H at I-70 Emma test site during Phase I (Loehr and Bowders, 2007).

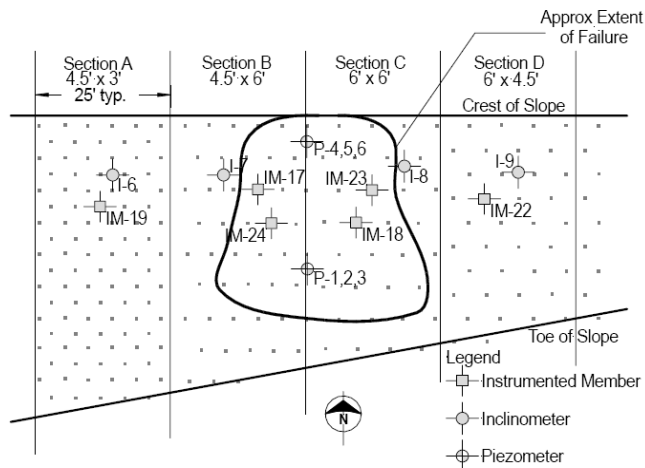

Figure 3.26: Approximate extent of failure at I-70 Emma site (Loehr and Bowders, 2007).

### 3.6 Cost Analysis

A cost estimate for surficial slope repairs using structural reinforcing members generally is difficult to predict without specific information regarding the site accessibility, soil properties and conditions, size of the failure area, characteristics of reinforcing structural members (material type and properties, cross-section, and length), and the availability of construction equipment and contractors.

The data collected in this study include a cost estimate of reinforcing structural members based on their characteristics and the cost of installing these members. The cost estimates reported in the literature also are presented.

The literature reviewed during this study and personal communications with engineers and contractors indicated that surficial slope stabilization using conventional reinforcing members, launched soil nails, and earth anchors is more cost effective when compared with conventional methods. This claim was not validated by the research team as it requires project-specific cost data in addition to long-term performance data of these projects, which are not available.

#### 3.6.1 Conventional Structural Members

Personal communications with various manufacturers indicated that there are different types of plastic lumber and their costs are not the same. The plastic lumber type recommended for structural applications is more expensive than the normal type. Generally, commercial names are given by manufacturers to distinguish plastic lumbers. For example, Bedford Technology® calls their reinforced recycled plastic lumber FIBERFORCE®. Table 3.15 presents a cost estimate for typical plastic lumber as obtained from a selected major manufacturer.

Table 3.15: Cost estimate of various plastic lumber members.

Shape	Size (in.)		Maximum available length (ft.)	Weight (lb./ft.)	Unit price (\$/ft.)		
	Nominal	Actual			Black	Brown and dark gray	White and yellow
Round	2.5	2.25	8	1.80	\$2.18	\$2.29	\$2.91
Round	4.0	3.9	12	4.80	\$5.81	\$6.52	\$8.00
Square	2×2	1.5×1.5	8	1.0	\$1.67	\$1.76	\$2.79
Square	4×4	3.5×3.5	16	4.80	\$6.38	\$6.63	\$8.16
Square	4×4	4×4	16	7.91	\$7.91	\$8.30	\$10.28
Square	5×5	4.5×4.5	16	7.60	\$9.82	\$10.56	\$12.89
Square	6×6	5.5×5.5	20	10.50	\$12.93	\$13.80	\$17.26
Square	8×8	7.5×7.5	16	21.10	\$25.31	\$26.64	\$32.36
Square	10×10	9.75×9.75	20	36.00	\$42.79	\$46.69	\$59.83

Normal wood lumber is better known as pressure-treated or green lumber for subsurface applications. Table 3.16 presents cost estimates for typical treated lumber obtained from a supplier in the Milwaukee area.

Table 3.16: Cost estimate of small scale treated wood lumber.

Shape	Lumber Size	Actual Dimensions	Length Available (ft.)	Weight (lb./ft.)	Price	Unit price (\$/ft.)
Square	2" x 2"	1.5" x 1.5"	8	0.537	\$2.79	\$0.35
	4" x 4"	3.5" x 3.5"	8	2.921	\$6.97	\$0.87
			10	2.921	\$8.97	\$0.90
			12	2.921	\$9.97	\$0.83
	6" x 6"	5.5" x 5.5"	8	7.214	\$19.97	\$2.50
			10	7.214	\$27.97	\$2.80
12			7.214	\$29.97	\$2.50	

Small scale lumber is more common in residential applications. A cost estimate for large size timber used for piles and poles also is given in Table 3.17.

Table 3.17: Cost estimate of treated wood lumber used for piles and poles (American Pole and Timber, 2007).

Lumber Size	Note	Length Available (ft.)	Weight (lb./ft.)	Price (\$)	Unit price (\$/ft.)
9" Round	Poles taper	35	15.169	\$145.00	\$4.14
10" Round	approximately 1"	40	18.727	\$205.00	\$5.13
11" Round	in diameter per	45	22.660	\$260.00	\$5.78
12" Round	ten feet of length	55+	26.967	\$455.00	\$8.27
4 x 4	Milled smooth	24+	3.815	\$35.00	\$1.46
6 x 6	4S4	24+	8.584	\$68.00	\$2.83
8 x 8		32+	15.260	\$220.00	\$6.88
10 x 10		32+	23.844	\$323.00	\$10.09
12 x 12		32+	34.335	\$545.68	\$17.05

The cost estimate for steel pipes of relatively small diameter is shown in Table 3.18. Various types of steel pipes are shown with large variations in their unit price.

Table 3.18: Cost estimate of various steel pipe piles.

Member Size (in.)	Description	Length (ft)	Unit price (\$/ft)	Price (\$)
3 in. (3.50 OD × 0.300 wall)	Structural carbon steel pipe - coated	8	\$28.30	\$226.36
4 OD × 0.120 wall × 3.76 ID	Welded - structural round steel tube	8	\$14.91	\$119.28
4 in. Diameter	Cold rolled / finish steel round	12	\$51.27	\$615.24
4 OD × 0.250 Wall × 3.50 ID	Seamless structural round steel tube	8	\$37.53	\$300.24

The unit cost for stabilizing a surficial slope failure using plastic reinforcing members varies with the member type and spacing, and costs between \$1.00/ft.<sup>2</sup> and \$4.50/ft.<sup>2</sup> (MOinfo newsletter, 2005). The cost of installing recycled plastic members in one of the Missouri sites was approximately \$40.00/member, including the cost of the members (Loehr, 2007). Loehr et al. (2000) reported that the cost to stabilize areas S1 and S2 at the Emma site was \$3.91/ft.<sup>2</sup>. He reported that the cost of a plastic structural member is \$20.00 and the cost of installing each member is \$16.56. The current market prices are higher than the previously given figures. Table 3.19 presents cost estimates of some of the equipment used for installing recycled plastic members.

Table 3.19: Cost estimate of construction equipment.

Construction Equipment	Year Manufactured	Price
Case 580 Backhoe with Kent KF9 hydraulic hammer	New	\$80,600 backhoe \$18,000 hammer
Davey-Kent DK100B track-mounted hydraulic drill rig	Early 1990's	\$55,000
Ingersoll Rand ECM3500 track-mounted pneumatic hammer drill rig	2002	\$100,000
	1987	\$50,000
	Early 1970's	\$31,500
Case 420 Skid Steer with Edge PD-35 post pounder	New	\$23,300 Skid Steer \$7,000 post pounder

In order to provide a current cost estimate, a hypothetical example of surficial slope failure is considered. The failure area is 40 ft. × 21 ft. (7,560 ft.<sup>2</sup>), which will be stabilized using 4 in. × 4 in. × 8 ft. plastic members (unit price = \$6.38/ft.). Reinforcing member spacing of 3 ft. in both directions was selected, indicating that 902 members were needed at a total cost of \$46,038.

Personal communications with the pile driving industry in the Milwaukee area indicated that contractors charge mobilization costs between \$5,000 and \$10,000, and the cost of small diameter pile driving ranges from \$25/ft. to \$30/ft. These figures are high considering the fact that light equipment can be used for installation, as presented in the construction section of this report. Therefore, the estimate of approximately \$20/member is considered reasonable, which was the construction cost estimate from the Missouri study (Loehr 2007). Based on this example and considering plastic, timber, and steel pipe members, the unit cost of stabilizing surficial slope failure is: \$8.47/ft.<sup>2</sup> for plastic members, \$3.22/ft.<sup>2</sup> for treated wood lumber, and \$16.62/ft.<sup>2</sup> for structural round steel tubes (4 in.).

### **3.6.2 Launched Soil Nails**

The use of launched soil nails may extend beyond the “*surficial slope failures*,” since the length of the reinforcing members is about 20 ft. The cost of installing launched nails ranges between \$300 and \$600 per launched nail in addition to mobilization expenses. When the lower price range is considered to obtain a cost estimate of the previously mentioned example, the unit cost of slope stabilization is \$35.79/ft.<sup>2</sup> of slope face without the mobilization expenses, assuming the nail spacing is 3 ft. This is more than four times the cost of using plastic lumber.

### **3.6.3 Earth Anchoring Systems**

The example in Section 3.5.2 is used to obtain a cost estimate for using earth anchors to stabilize surficial slope failures. The Platipus standard S6 AnchorMatR System is selected, which is suitable for stabilizing shallow slope failures that do not exceed 2.5 ft. The anchor S6 Geo with a 4.5 ft. long wire tendon (1 ton ultimate load on the system) and anchor spacing of 4 ft. horizontal × 4 ft. vertical will be used. Turf matting installation is included. The cost estimate ranges between \$3.15/ft.<sup>2</sup> and \$3.60/ft.<sup>2</sup> of slope face.

### 3.7 Slope Stability Analysis Using Wisconsin Input Parameters

A comprehensive slope stability analysis was conducted using Wisconsin soil and slope input parameters. The objective was to investigate the influence of installing structural members for stabilizing surficial slope instabilities along Wisconsin highway slopes and embankments. The analysis was conducted using a variety of soil strength parameters under dry and saturated conditions.

The surficial slope failure along STH-164 in Waukesha County was selected for the analysis. Soil samples were obtained for preliminary laboratory tests and field measurements of the extent and depth of the slope were carried out. Details of the field and laboratory testing on this slope were described in Chapter 2.

The commercial software SLOPE/W was selected to perform the analysis using the procedure of slices of Morgenstern-Price (1965). The analysis was performed using the STH-164 slope and soil input parameters and under various soil conditions as follows:

1. Slope geometry of 2.5H:1V
2. Slope consists of one homogeneous soft soil layer (Figure 3.27) with the following properties:
  - a. Shear strength parameters with combinations of angle of internal friction  $\phi = 15, 20, \text{ and } 26^\circ$  and cohesion  $c = 0, 20, \text{ and } 50 \text{ lbs/ft.}^2$
  - b. Unit weight  $\gamma = 120 \text{ lbs/ft.}^3$
3. Slope consists of two soil layers (Figure 3.28) with the following properties:
  - a. Upper soft soil layer with combinations of shear strength parameters  $\phi = 15, 20, \text{ and } 26^\circ$ ;  $c = 0, 20, \text{ and } 50 \text{ lbs/ft.}^2$ ; and  $\gamma = 115 \text{ lbs/ft.}^3$
  - b. Depth of the upper soil layer  $d = 4 \text{ ft}$
  - c. Lower stiff soil layer with  $\phi = 28^\circ$ ,  $c = 200 \text{ lbs/ft.}^2$ , and  $\gamma = 120 \text{ lbs/ft.}^3$
4. Soil conditions with respect to saturation and pore water pressure:
  - a. Slope is completely dry with no pore water pressure used in the analysis
  - b. Slope is completely saturated with water perched on the lower soil layer; pore water pressure was used in the analysis
  - c. No seepage was considered
5. Slope stabilization schemes:
  - a. No slope stability scheme was used
  - b. Slope was stabilized using vertical structural members (Figures 3.29 and 3.30) with allowable shear strength  $R_m = 4.5 \text{ kips}$  and spacing of  $3 \text{ ft.} \times 3 \text{ ft.}$ . The length of the reinforcing structural member  $l = 8.0 \text{ ft.}$

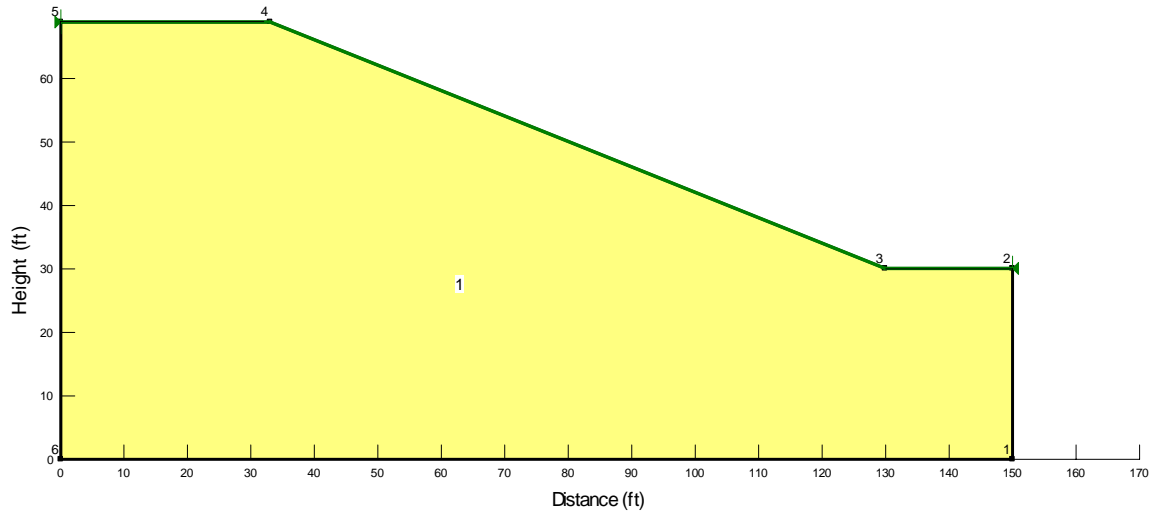

Figure 3.27: Geometry of STH-164 highway slope that consists of one soft homogeneous soil layer with different combinations of shear strength parameters.

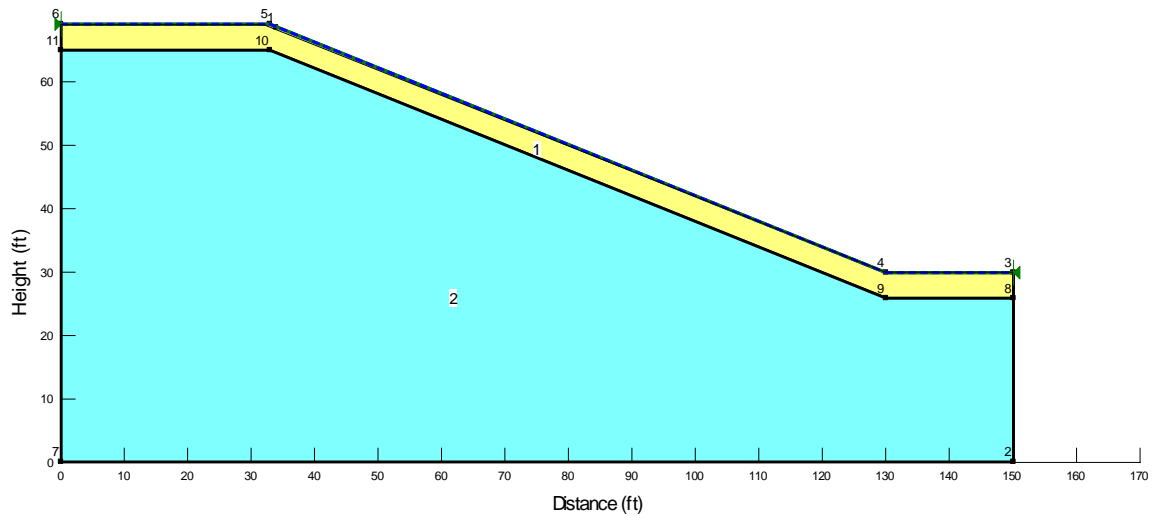

Figure 3.28: Geometry of STH-164 highway slope that consists of an upper soft soil layer over a stiff soil layer with different combinations of shear strength parameters.

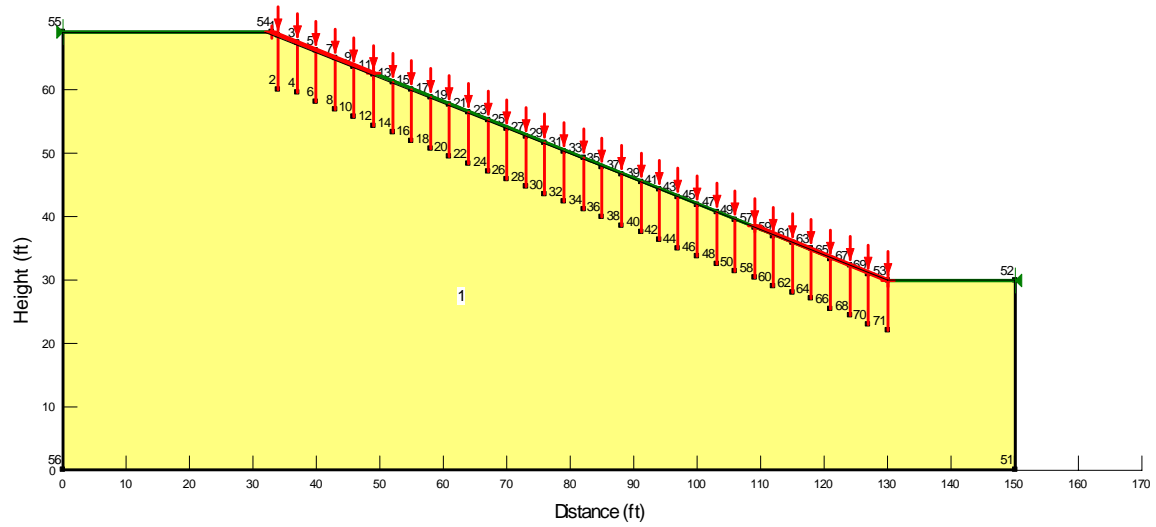

Figure 3.29: Geometry of STH-164 highway slope that consists of one soft homogeneous soil layer stabilized with vertical structural members.

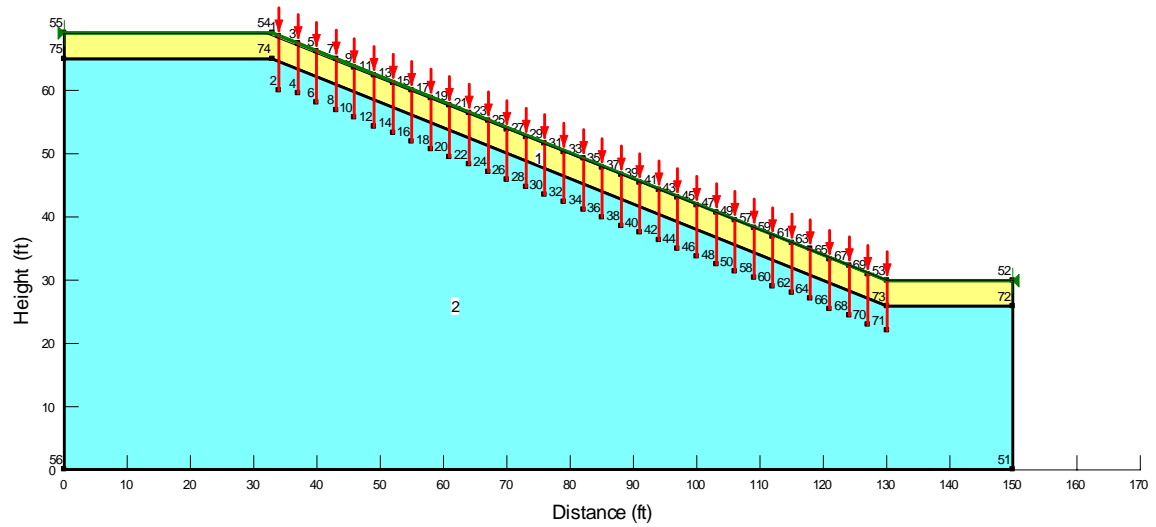

Figure 3.30: Geometry of STH-164 highway slope that consists of an upper soft soil layer over a stiff soil layer stabilized with vertical structural members.

### Homogeneous Soft Soil Layer without Reinforcing Members

Figure 3.27 shows the slope geometry of STH-164, which is a cut section highway slope. It is assumed that the slope consists of one homogeneous soil layer. This assumption, combined with different shear strength parameters and saturation conditions can lead to a worst-case scenario in slope stability and the subsequent surficial failure of the slope. Figure 3.31 depicts results of the stability analysis of the slope under the shear strength parameters  $c' = 0$  psf and  $\phi' = 20^\circ$ . The soil is assumed to be dry and no pore water pressure influence exists. The Morgenstern-Price (1965) method of slices was used to perform the stability analysis and to locate the slip (sliding) surface with the minimum factor of safety. The analysis using  $c' = 0$  psf and  $\phi' = 20^\circ$  showed that the slope will undergo surficial slope failure with an approximate maximum slip surface depth  $d = 2$  ft. The calculated factor of safety is 0.907. The slope with the given geometry, soil properties, and conditions will undergo a shallow failure. as shown in Figure 3.31.

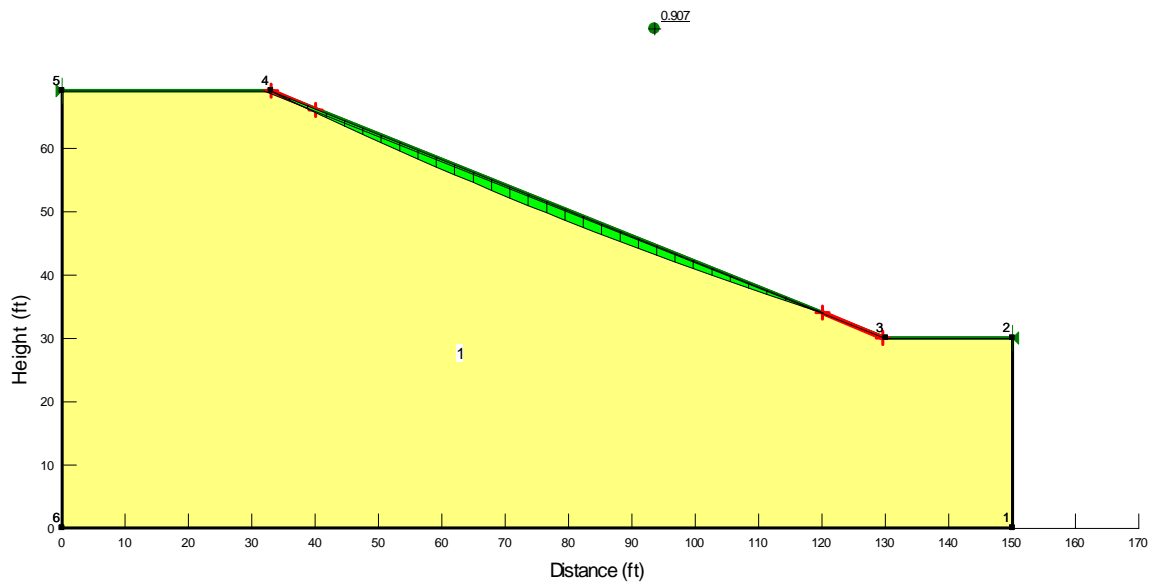

Figure 3.31: Surficial slip surface of the STH-164 slope with dry homogeneous cohesionless soil ( $\phi'=20^\circ$ ).

Another unstable case scenario occurred when the soil was fully saturated. The results are shown in Figure 3.32. The factor of safety of 0.360, corresponding to a surficial sliding surface shown in the Figure, was obtained. The maximum depth of the sliding surface is approximately 1.8 ft. The effect of saturation decreased the minimum factor of safety of the slope from 0.907 to 0.360, which also resulted in a surficial type of failure.

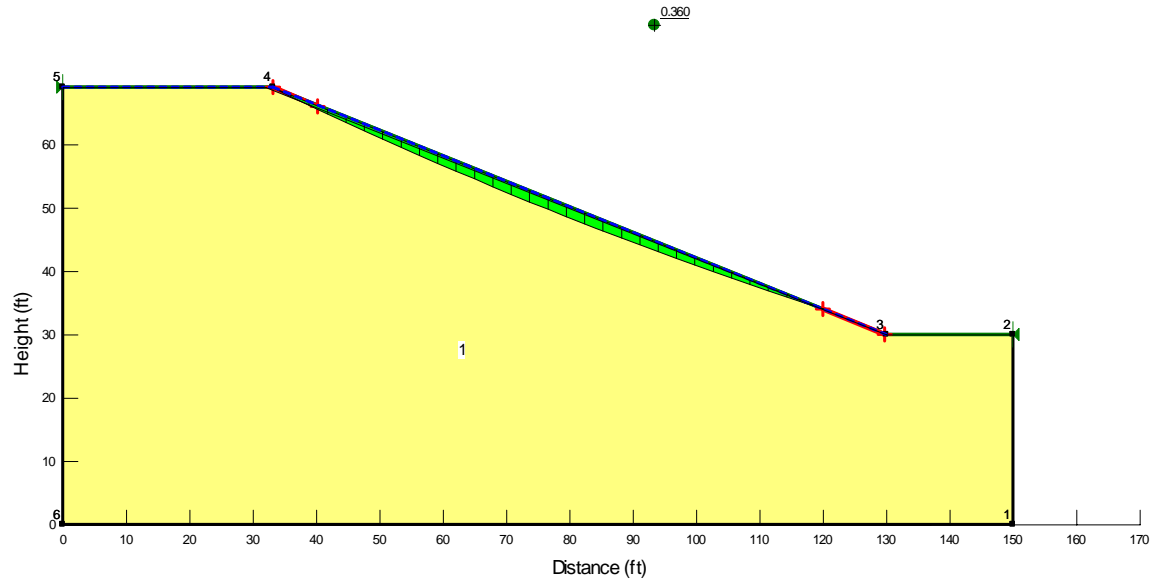

Figure 3.32: Surficial slip surface of the STH-164 slope with saturated homogeneous cohesionless soil ( $\phi'=20^\circ$ ).

The stability analysis was repeated using a dry homogeneous soil with shear strength parameters of  $c' = 20$  psf and  $\phi'=20^\circ$ . The sliding surface with the lowest factor of safety (Figure 3.33) has become deeper with  $d= 10$  ft. around the middle of the sliding surface. This means that with the given slope geometry, soil properties, and soil conditions, surficial failure is not possible; however is obvious that soil cohesion plays an important role in terms of slope stability.

When the slope shown in Figure 3.33 is analyzed with saturated soil conditions, the factor of safety is reduced to  $FS=0.466$  with a maximum sliding surface depth of 10 ft. The results of the analysis are shown in Figure 3.34.

The previous analyses show that when the soil is soft (i.e., low shear strength parameters) and dry, it may exhibit a surficial slope failure with an approximate depth of 2 ft. The assumption of soft soil is reasonable since surficial soil in embankments and highway slopes (cut sections) is usually disturbed during construction activities. Moreover, compaction of the soil in the upper parts of slopes and embankments may not largely improve the shear strength of the soil due to lack of confinement.

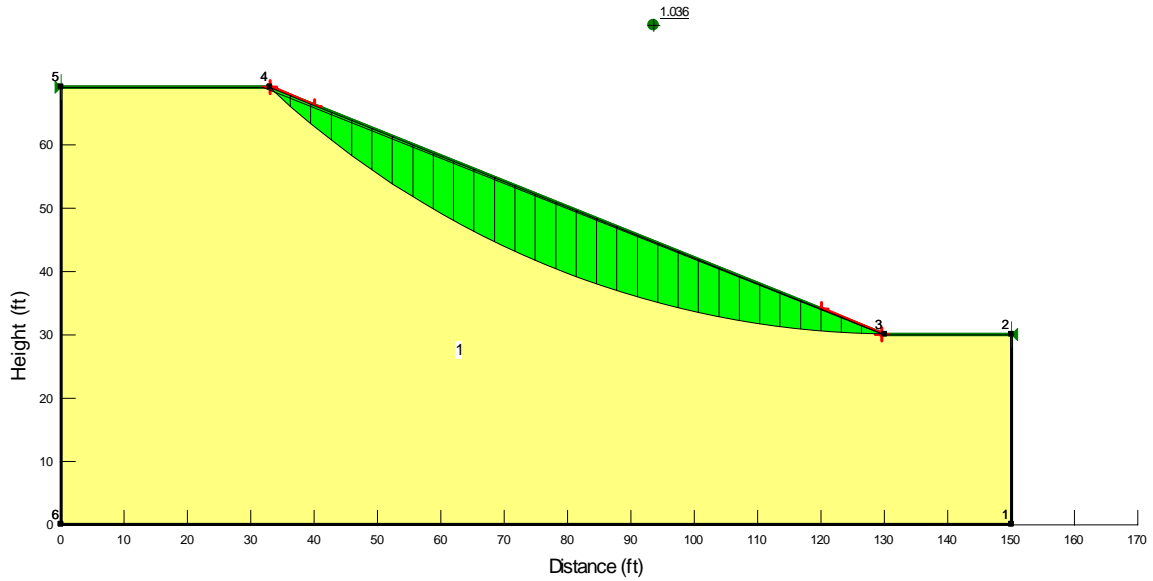

Figure 3.33: Relatively deep slip surface of the STH-164 slope when analysis is conducted with dry soft homogeneous soil layer ( $c' = 20$  psf and  $\phi' = 20^\circ$ ).

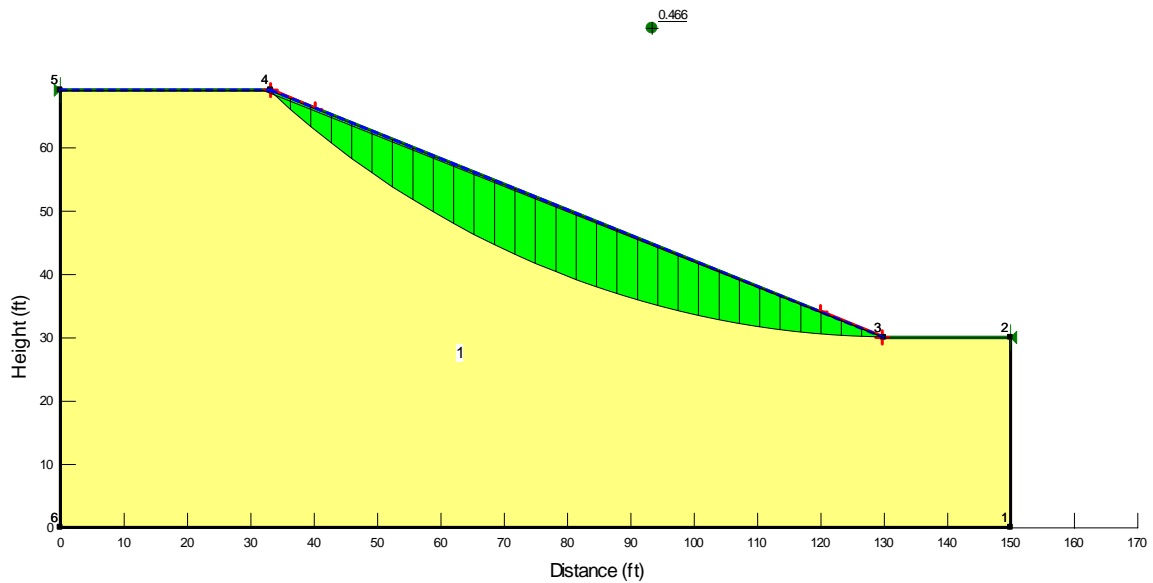

Figure 3.34: Relatively deep slip surface of the STH-164 slope obtained when analysis is conducted with saturated soft homogeneous soil layer ( $c' = 20$  psf and  $\phi' = 20^\circ$ ).

The above analysis indicates that slopes with reasonably high shear strengths may not attain surficial (shallow) slope failures even when they become saturated. Saturation in this case causes slope failure that is not surficial, as shown in Figure 3.34.

### Homogeneous Soft Soil Layer with Reinforcing Members

The effect of installing a structural member on the stability of surficial slope failure is investigated. Figure 3.35 presents the geometry of the STH-164 slope with a dry homogeneous soil layer stabilized with vertical structural members. Based on the information collected from the literature, these structural members can be plastic lumber with 3.5 in.  $\times$  3.5 in. in a cross-sectional area. The allowable shear capacity is 4.5 kips (considering a factor of safety of 2). Eight-foot long reinforcing structural members are installed vertically with a spacing of 3 ft.  $\times$  3 ft. Stability analysis with reinforcing structural members showed that the factor of safety increased from 0.907 (without reinforcing members) to 1.205 with reinforcing members in the case of homogenous dry cohesionless soil. In addition, the slip surface moved deeper from  $d_{max} = 2$  ft. to about  $d_{max} = 15$  ft., which means that installing these vertical structural members has eliminated the surficial soil stability problem. When the analysis was conducted with a saturated soil, the factor of safety decreased to 0.535, as shown in Figure 3.36. The slip surface also is located deeper than what is considered shallow failure.

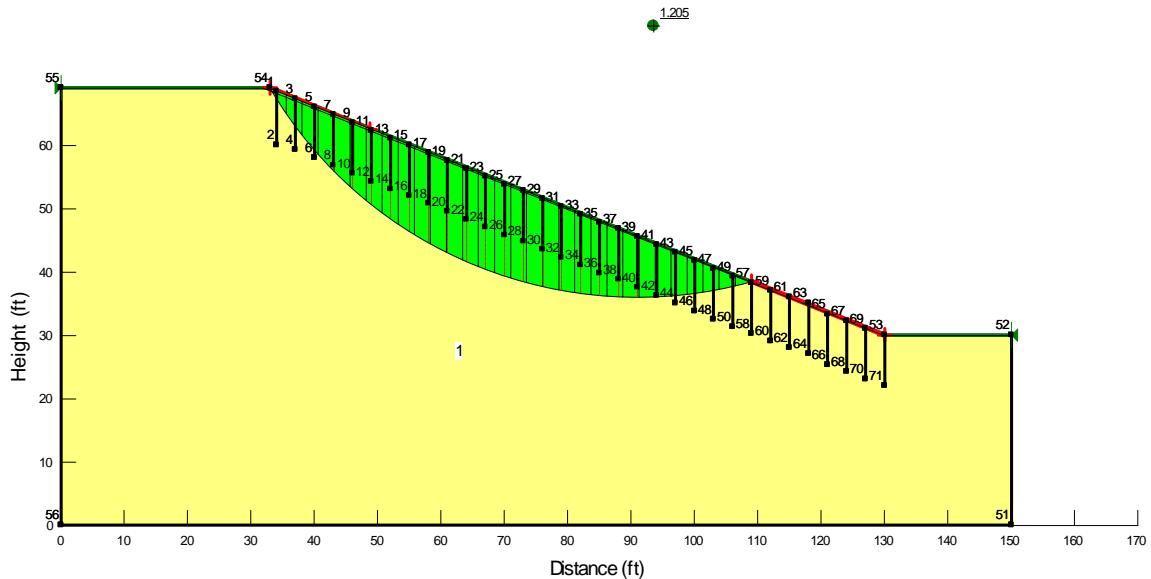

Figure 3.35: Slip surface of STH-164 slope that consists of dry homogenous soil layer ( $\phi' = 20^\circ$ ) reinforced with 8-ft. vertical structural members.

The purpose of the above analysis is to demonstrate the effectiveness of the structural members in alleviating shallow slope failures. Not only is the factor of safety of the slope improved but the slip surface also is pushed deeper. This is important since these analyses were conducted assuming poor strength conditions of the surficial soil. Deeper soil layers are usually confined and likely to have higher shear strengths. When soil strength parameters are in the medium level such as  $c' = 200$  psf and  $\phi' = 20^\circ$ , the factor of safety of the saturated reinforced slope is  $FS = 1.041$  and the slip surface is moved deep to  $d = 25$  ft. at the maximum point, as shown in Figure 3.37.

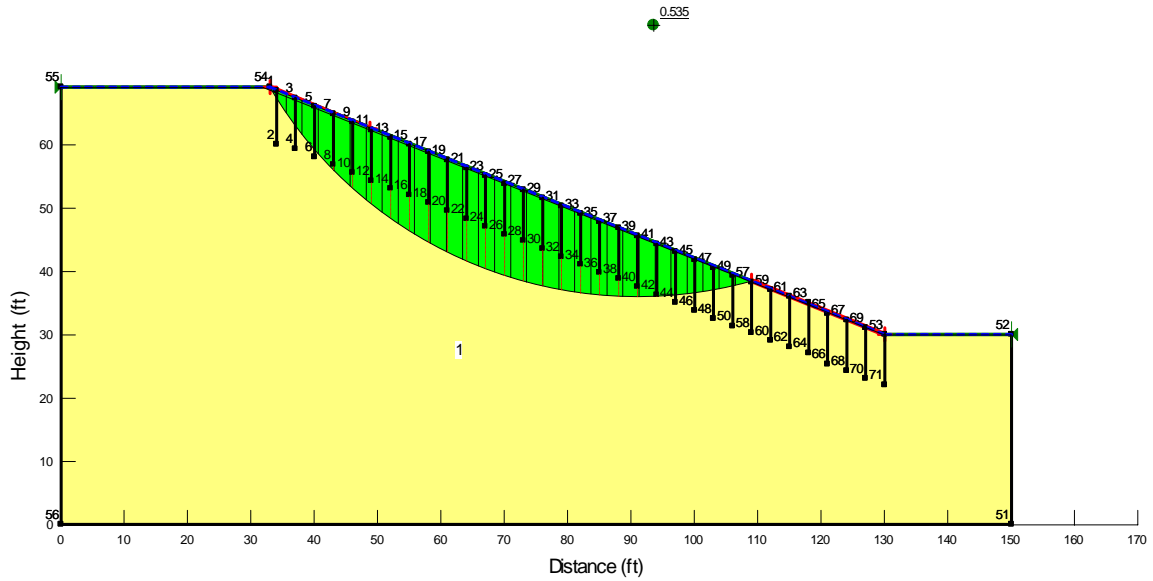

Figure 3.36: Slip surface of STH-164 slope that consists of a saturated homogenous soil layer ( $\phi' = 20^\circ$ ) reinforced with 8-ft. vertical structural members.

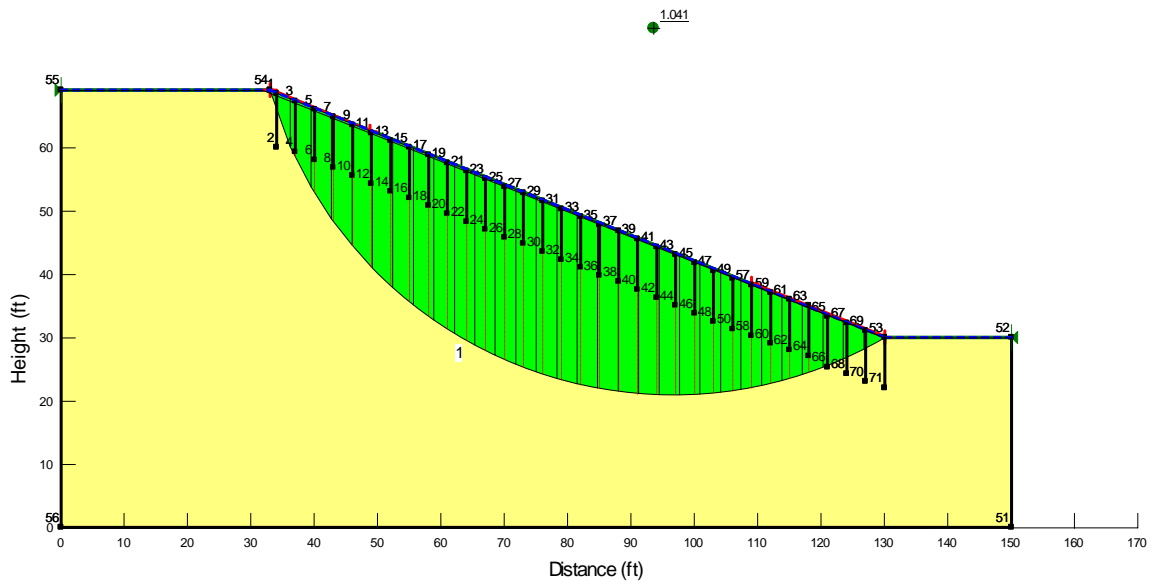

Figure 3.37: Slip surface of STH-164 slope that consists of a saturated homogenous soil layer ( $c' = 200$  psf and  $\phi' = 20^\circ$ ) reinforced with 8-ft. vertical structural members.

The analysis was repeated using a wide range of soft soil parameters and the results are summarized in Table 3.20, which also provides information about the influence of the reinforcing structural members in dry and saturated weak soils.

Table 3.20: Summary of factor of safety obtained from the stability analysis of the STH-164 slope with and without reinforcing structural members and a homogenous soil layer of different strength parameters and saturation conditions.

Shear strength parameters		Slope without reinforcing structural members		Slope with reinforcing structural members	
Cohesion $c'$ (psf)	Angle of internal friction $\phi'$ ( $^\circ$ )	Dry soil conditions	Saturated soil conditions	Dry soil conditions	Saturated soil conditions
0	15	0.668	0.265	0.887	0.394
20	15	0.782	0.362	0.949	0.451
50	15	0.891	0.460	1.042	0.539
100	15	1.034	0.568	1.197	0.671
150	15	1.146	0.677	1.337	0.772
200	15	1.259	0.788	1.458	0.866
0	20	0.907	0.360	1.205	0.535
20	20	1.036	0.466	1.267	0.592
50	20	1.145	0.570	1.360	0.679
100	20	1.324	0.694	1.515	0.822
150	20	1.436	0.802	1.670	0.946
200	20	1.548	0.912	1.806	1.041
0	26	1.216	0.482	1.615	0.716
20	26	1.364	0.603	1.677	0.773
50	26	1.472	0.710	1.770	0.860
100	26	1.655	0.857	1.924	1.007
150	26	1.810	0.964	2.079	1.141
200	26	1.922	1.073	2.234	1.266
0	30	1.439	0.571	1.912	0.845
20	30	1.601	0.701	1.974	0.903
50	30	1.710	0.808	2.066	0.991
100	30	1.892	0.976	2.221	1.138
150	30	2.074	1.082	2.376	1.282
200	30	2.193	1.190	2.535	1.406

#### *Layered Soil without Reinforcing Members*

Stability analyses also were conducted using the slope geometry of STH-164 with the assumption that the slope consists of two soil layers: a 4-ft. thick upper soft soil layer and a lower stiff soil layer. The upper soil layer is assumed to possess different combinations of shear strength parameters and saturation conditions. The lower soil layer is assumed to have shear strength parameters  $c' = 200$  psf and  $\phi' = 28^\circ$ . The saturated unit weight of the upper and lower soil layers is  $\gamma_{sat} = 115$  and  $\gamma_{sat} = 120$  pcf, respectively, to maintain the upper soil layer as the soft medium and subsequently to experience the surficial instability. Figure 3.38 depicts the results of the stability analysis of the slope with the shear strength parameters  $c' = 20$  psf and  $\phi' = 15^\circ$  for the upper soil layer. The soil is assumed to be dry. The analysis using  $c' = 20$  psf and  $\phi' = 20^\circ$  indicated that the slope would undergo surficial slope failure with  $d_{max} = 2$  ft. The factor of safety for this case is 1.085. The slope with the given geometry, soil properties, and conditions is stable.

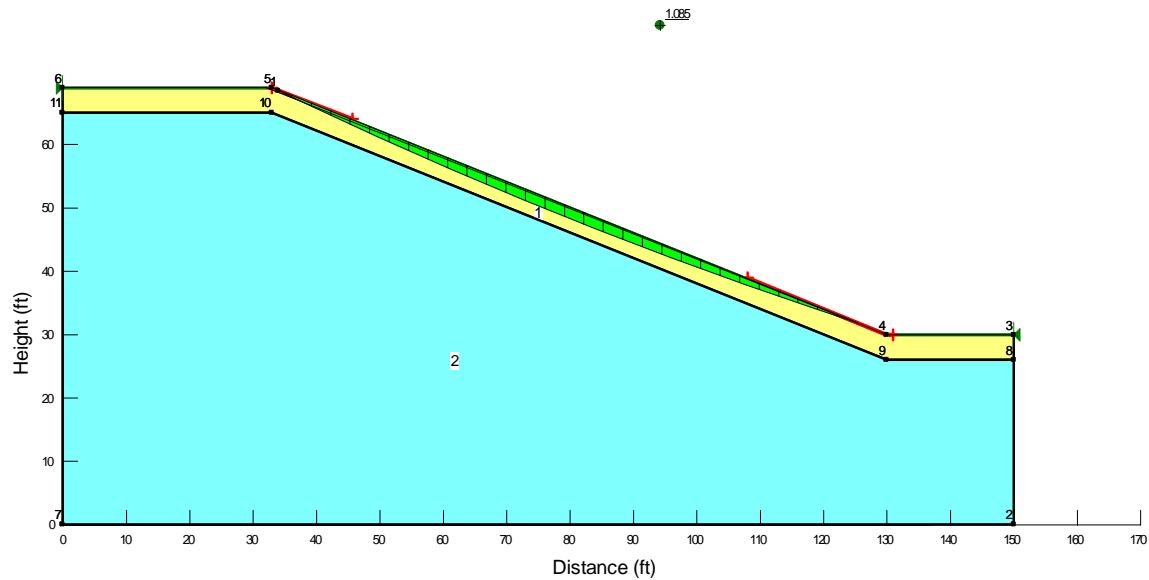

Figure 3.38: Surficial slip surface of the STH-164 slope with upper soft dry soil ( $c' = 20$  psf and  $\phi' = 15^\circ$ ) and lower stiff dry soil ( $c' = 200$  psf and  $\phi' = 28^\circ$ ).

When the soil layers are fully saturated, the factor of safety decreases from  $FS = 1.085$  (dry condition) to  $FS = 0.664$  (saturated condition). The sliding surface was maintained as surficial with  $d_{max} = 1.8$  ft. The results of this analysis are presented in Figure 3.39.

The above analyses show that when the upper soil layer is soft (i.e., low shear strength parameters) and dry, it may exhibit a surficial slope failure with  $d_{max} = 2$  ft. The assumption of an upper soft soil layer is reasonable since many surficial failures of embankments and highway slopes (cut sections) usually are pushed back and used to rebuild the slope. Compacting the upper failed soil may not result in improved shear strength. The presence of water within the soil in the slope reduces the shear strength of the soil and aggravates the factor of safety.

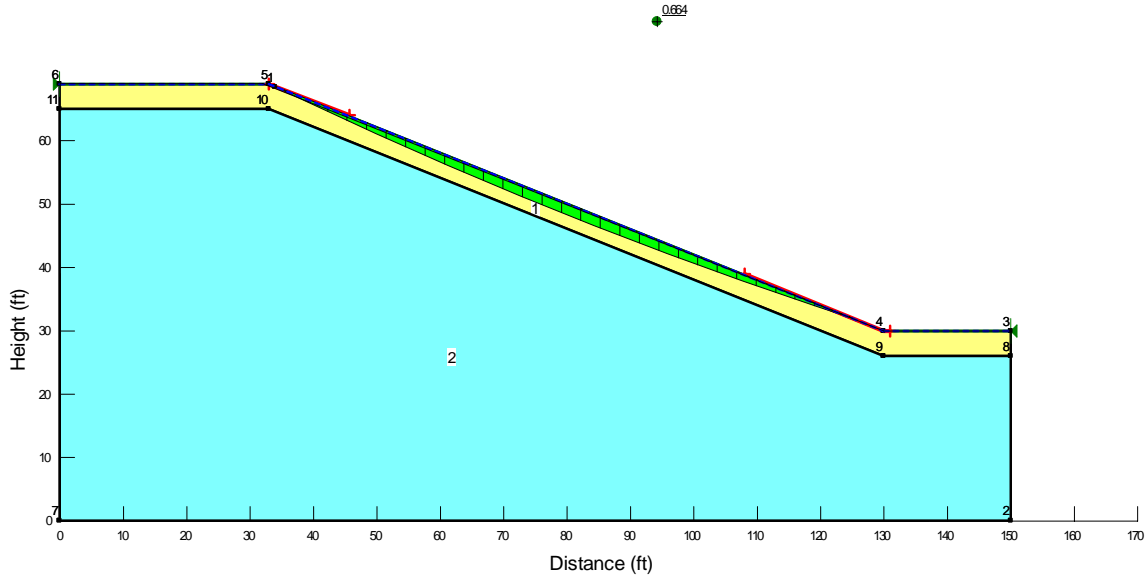

Figure 3.39: Surficial slip surface of the STH-164 slope with upper soft saturated soil ( $c' = 20$  psf and  $\phi' = 15^\circ$ ) and lower stiff saturated soil ( $c' = 200$  psf and  $\phi' = 28^\circ$ ).

#### *Layered Soil with Reinforcing Members*

The effectiveness of structural members in alleviating surficial slope failures of layered soil systems is investigated. Figure 3.40 presents the geometry of the STH-164 slope with dry soil layers stabilized with vertical structural members. Plastic lumber members with 3.5 in.  $\times$  3.5 in. cross-sectional area, allowable shear capacity of 4.5 kips, and a length of 8 ft., were used in the analysis. The structural members are placed with a spacing of 3 ft.  $\times$  3 ft. Stability analysis with reinforcing structural members showed that the factor of safety increased from  $FS = 1.085$  without reinforcing members to  $FS = 2.299$  with reinforcing members in the case of dry soil with upper soft soil strength parameters of  $c' = 20$  psf and  $\phi' = 15^\circ$ . In addition, the maximum depth of the slip surface increased from depth  $d_{max} = 2$  ft to about  $d_{max} = 15$  ft., which means that installing these vertical structural members has improved the surficial soil stability. When the analysis is conducted with saturated soils, the factor of safety decreased to  $FS = 1.299$ , as shown in Figure 3.41. The maximum depth of slip surface also increased to  $d_{max} = 14.5$  ft.

The stability analysis considering layered soil demonstrates the significant contribution of the structural members in the stability of shallow slope failures. Installing these members increased the factor of safety of the slope and moved the critical slip surface deep into soils that may not be affected significantly by rainfall events.

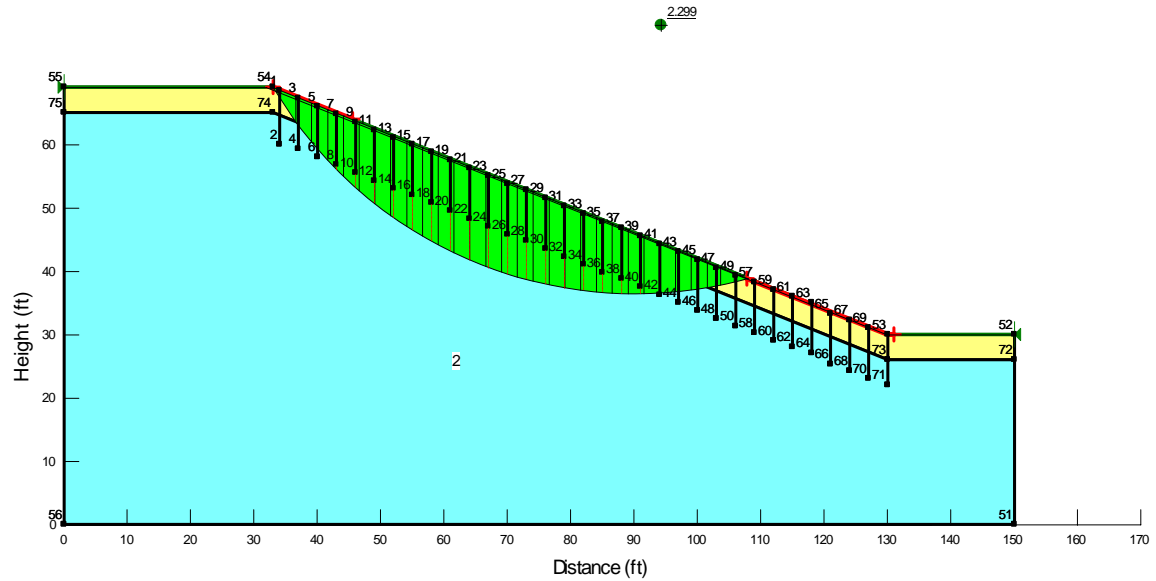

Figure 3.40: Slip surface of STH-164 slope that consists of a dry homogenous soil layer ( $c' = 200$  psf and  $\phi' = 15^\circ$ ) reinforced with 8-ft. vertical structural members.

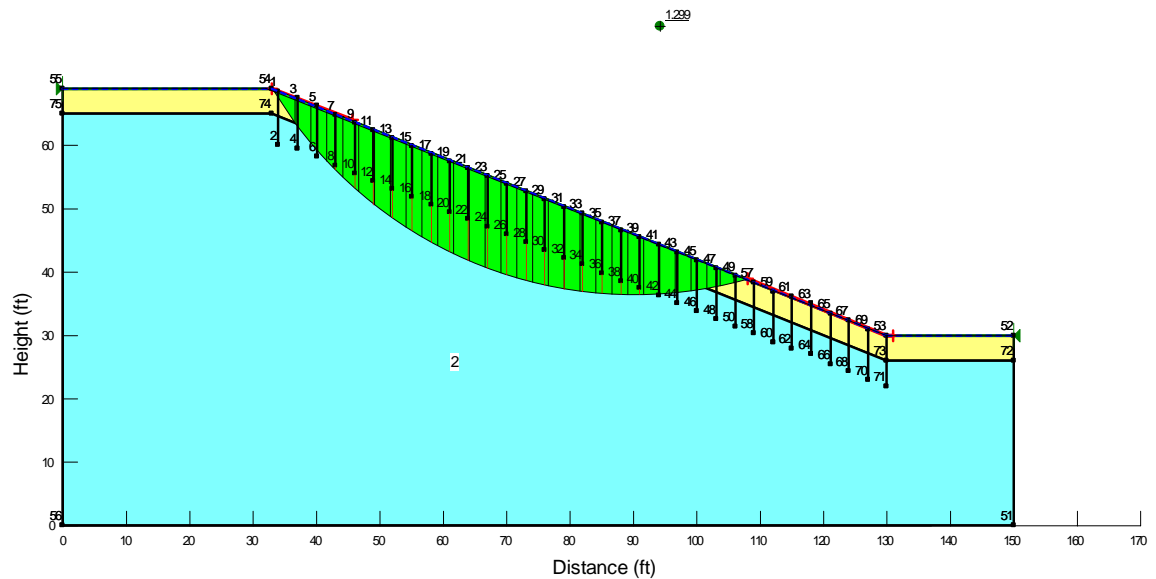

Figure 3.41: Slip surface of STH-164 slope that consists of a saturated homogenous soil layer ( $c' = 200$  psf and  $\phi' = 15^\circ$ ) reinforced with 8-ft. vertical structural members.

Additional stability analyses were carried out using a range of upper soft soil parameters. The results are summarized in Table 3.21, which provides information on the influence of the reinforcing structural members in layered soils with upper soft soil and lower stiff soil under dry and saturated soil conditions.

Table 3.21: Summary of factor of safety obtained from the stability analysis of STH-164 slope with and without reinforcing structural members and two soil layers of different strength parameters and saturation conditions.

Shear strength parameters		Slope without reinforcing structural members		Slope with reinforcing structural members	
Cohesion $c'$ (psf)	Angle of internal friction $\phi'$ ( $^{\circ}$ )	Dry soil conditions	Saturated soil conditions	Dry soil conditions	Saturated soil conditions
0	15	0.668	0.247	2.289	1.289
20	15	1.085	0.664	2.299	1.299
50	15	1.711	1.290	2.314	1.306
0	20	0.907	0.336	2.302	1.302
20	20	1.324	0.753	2.312	1.309
50	20	1.950	1.378	2.327	1.314
0	26	1.215	0.450	2.318	1.316
20	26	1.633	0.867	2.328	1.319
50	26	2.014	1.493	2.342	1.324

It should be noted that in the current analyses, the slip surface depth was allowed to vary so that the weakest surface (critical surface) would be located. The factor of safety was then calculated for this critical surface. Therefore, the actual increase in the factor of safety due to installing vertical structural members can be obtained by repeating the analysis and forcing the soil to fail at the same pre-stabilized slip surface, not the critical one. The purpose of this analysis is to demonstrate the potential benefit of stabilizing slopes with structural members using Wisconsin slope and soil conditions.

## Chapter 4

### Conclusions and Recommendations

This research investigated the use of reinforcing structural members to stabilize surficial slope failures. The literature search and review conducted in this study indicated that the use of the structural members to stabilize surficial slope failures is not common practice; however, there is a great interest in this methodology, as a major research study was just completed in Missouri. Based on the literature review conducted, personal communications, and phone surveys with selected state highway engineers, the research team identified three innovative methods of surficial slope stability:

1. Installing small size structural members by conventional methods
2. Installing launched soil nails
3. Installing earth anchoring systems

The literature collected during this research was synthesized in this report. The summary includes detailed information regarding the design and analysis methodology for structural members, the material properties of the structural members used, construction methods, cost-effectiveness, and case histories. It should be noted that there was little documented information available on this subject due to the following reasons:

- a. This method is not very commonly used and currently is being researched
- b. Many state highway agencies deal with surficial slope failures as part of the routine maintenance work performed on the district level.

In order to investigate the influence of installing structural members to stabilize surficial slope instabilities in Wisconsin, a comprehensive slope stability analysis was conducted using Wisconsin soil and slope input parameters and various soil strength parameters under dry and saturated conditions. The analysis conducted in this report and analyses by other researchers demonstrated the effectiveness of using the structural members to stabilize surficial slope failures. The improvements were increased factor of safety and elimination of the surficial nature of the slope failure.

Based on the information and data available, the following conclusions are reached:

1. The methods that have potential merit to stabilize surficial slope failures in Wisconsin in terms of cost-effectiveness and field performance are the small size conventional structural members and the earth anchoring systems.
2. Short-term field performance data demonstrated that plastic lumber is an effective remediation method if installed in closely spaced configuration (3ft. spacing).
3. Wood lumber is a cost-effective choice.
4. Long-term field performance data on the use of these materials is not available to draw any rational conclusions. Creep of plastic lumber and

decay of wood lumber in aggressive environments may impact the behavior of these structural elements in the future and therefore the stability of the slopes they were used to repair.

5. The use of earth anchors also is a cost-effective choice.

These conclusions were reached based on the available literature compiled in this study. Definitive conclusions on the use and performance of these methods to stabilize shallow slope failures in Wisconsin can be reached by carrying out field experiments. Consequently, the research team provides the following recommendation:

Conduct a field research experiment in which the recommended methods are tested in WisDOT projects. Two sites of surficial slope failures (cut slope and embankments) can be identified and selected by WisDOT engineers in which different sections can be repaired using different structural members (plastic lumber, wood, steel pipes, and earth anchors). These sites will be subjected to complete field and laboratory testing to determine the soil properties and site conditions. In addition, a field monitoring program can be conducted, including installing inclinometers, performing visual surveys, and collecting climate data (from the nearest weather station) to obtain and analyze field performance data. This experiment will provide WisDOT with all necessary information described in this report (i.e., effectiveness of these methods in terms of construction, cost, and long-term performance) so that a decision can be made regarding the implementation of any of these methods to stabilize surficial slope failures in Wisconsin.

## References

- AASHTO (2001). *A Policy on Geometric Design of Highways and Streets*, 4<sup>th</sup> Edition.
- Abramson, L., Lee, T., Sharma, S., and Boyce, G., (2002). *Slope Stability and Stabilization Methods*, John Wiley, New York, 712 p.
- Axten, G., Day, R., (1990). "Softening of Fill Slopes Due to Moisture Infiltration," *Journal of Geotechnical Engineering*, ASCE, 116(9): pp. 1424 - 1427.
- Bowders, J.J., J.E. Loehr, H. Salim, and C-W Chen (2003). "Engineering Properties of Recycled Plastic Pins for Use in Slope Stabilization," *Journal of the Transportation Research Board*, Transportation Research Board, TRR 1849, pp. 39-46.
- Bowders, J., Loehr, J.E., and Chen, C-W, (2003). "Evaluation of Recycled Plastic Products in Terms of Suitability for Stabilization of Earth Slopes," Final Report to Missouri Department of Transportation and Recycled Materials Resource Center, Project RI98-007c, Report RDT 03-019, 125 p.
- Brand, E., (1985). "Geotechnical Engineering in Tropical Residual Soils" (Special Lecture), *Proceedings 1st International Conference on Geomechanics in Tropical Lateritic and Saprolitic Soils*, Brasilia, Vol. 3, pp. 23-91.
- Day, R., (1989). "Surficial Stability of Compacted Clay Slopes," *Journal of Geotechnical Engineering*, ASCE, 115(4), pp. 577 – 580.
- Day, R., (1993). "Surficial Slope Failure: A Case Study." *Journal of Performance of Constructed Facilities*, ASCE, 7(4), pp.264 – 269.
- Day, R., (1996) "Design and Repair for Surficial Slope Failures." *Practice Periodical on Structural Design and Construction*, ASCE, 1(3), pp. 83 - 87.
- Day, R. W., and Axten, G. W. (1989). "Surficial stability of compacted clay slopes." *J. Geotech. Engrg.*, ASCE, 115(4), 577-580.
- Duncan, M., Wright, S., (2005). *Soil Strength and Slope Stability*, New Jersey, John Wiley and Sons, Inc.
- Evans, D. A. (1972). *Slope Stability Report*. Slope Stability Committee, Department of Building and Safety, Los Angeles, CA.
- Gray, D., Leiser, A., White, C., (1980). "Combined Vegetative-Structural Slope Stabilization." *Civil Engineering – ASCE*; 50 (1): pp. 82 - 85.
- Hansen, M. J. (1984). "Strategies for classification of landslides." Slope instability. John Wiley & Sons, New York, N.Y., 1-25.
- Hollingsworth, R., and G. S. Kovacs (1981), "Soil slumps. and Debris Flows. Prediction and Protection." *Bulletin of Association of Engineering Geology*, Vol. 18, No. 1, pp. 17-28.
- Ito, T., and T. Matsui, (1975). "Methods to estimate lateral force acting on stabilizing piles," *Soils and Foundations*, Vol. 15, No. 4, pp. 43-59.
- Liew, W. (2000), *Stability Analysis of Slopes Reinforced with Recycled Plastic Pins*, M.S Thesis, University of Missouri, 208 p.
- Loehr, J.E., Bowders, J., Owen, J., Sommers, L. and Liew, L., (2000). "Stabilization of Slopes Using Recycled Plastic Pins," *Journal of the Transportation Research Board*, National Academy Press, No. 1714, Paper No. 00-1435, pp. 1-8.
- Loehr, J.E., Bowders, J., and Salim, H., (2000), *Slope Stabilization Using Recycled Plastic Pins – Constructability*, Missouri Department of Transportation, RDT 00-007, 74 p.

- Loehr, J.E., and J.J. Bowders (2003), "Slope Stabilization Using Recycled Plastic Pins: Phase II – Assessment in Varied Site Conditions," Missouri Department of Transportation, RDT 03-016, 214 p.
- Loehr, J.E., and J.J. Bowders (2007), "Slope Stabilization Using Recycled Plastic Pins – Phase III," Research Report RI98-007D, Prepared for the Missouri Department of Transportation, 289 p.
- Loehr, J.E., Parra, J.R., E-C Ang, and J.J. Bowders (2004). "Design Method for Slope Stabilization Using Recycled Plastic Pins," *Proceedings of Geo-Trans 2004: Geotechnical Engineering for Transportation Projects*, M.K. Yegian and E. Kavazanjian, Editors, ASCE, GSP 126, Vol. 1, pp. 723-731.
- Platipus, (2007). Personal Communication.
- Poulos, H.G., and E.H. Davis (1980). *Pile foundation analysis and design*, John Wiley and Sons, New York.
- Pradel, D., and Raad, G. (1993). "Effect of Permeability on Surficial Stability of Homogeneous Slopes," *Journal of Geotechnical Engineering*, ASCE, Vol. 119, No. 2, pp. 315-332.
- Reid, M., Nielsen, H., and Dreiss, S., (1988). "Hydrologic Factors Triggering a Shallow Hillslope Failure," *Bulletin of the Association of Engineering Geologists*, Vol. XXV, No. 3, pp. 349-361.
- Skempton, A., and Delory, F., (1957). "Stability of Natural Slopes in London Clay," *Proceedings 4<sup>th</sup> International Conference on Soil Mechanics and Foundation Engineering*, London, England, Butterworths, Vol. 2, pp. 378-381.
- Slope/W (2007). Geo-slope, Canada.
- Slosson, J., and Krohn, J., (1982). "Southern California Landslides of 1978 and 1980," Storms, Floods, and Debris Flows in Southern California and Arizona 1978 and 1980, *Proceedings of a Symposium*, September 17-18. Washington, DC: National Academy Press, pp. 291-319.
- Spancrete, (2007). Personal Communication.
- Soil Nail Launcher, (2007). Personal Communication.
- Sommers, L., J.E. Loehr, and J.J. Bowders (2000), "Construction Methods for Slope Stabilization Using Recycled Plastic Pins," *Proceedings of the Mid-Continent Transportation Symposium*, Iowa State University, Ames, Iowa, May 15-16, pp. 254-258.
- Stanic, B., (1984). "Influence of Drainage Trenches on Slope Stability." *Journal of Geotechnical Engineering*, ASCE, 110(11), pp. 1624 – 1636.
- U.S. Department of Agriculture, (1971). *Soil Conservation Service, Soil Survey of Milwaukee and Waukesha Counties*.
- U.S. Department of Agriculture, (1973). *Soil Conservation Service, Soil Survey of Fond du Lac County*.
- Wisconsin Department of Transportation (2005). *Facilities Development Manual*.
- Wisconsin Department of Transportation (2003). *Standard Specifications for Highway and Structure Construction*.
- Zimmer, A. and Titi, H., (2007). "Evaluation of Shallow Slope Failures and Repairs along Wisconsin Highways," *1<sup>st</sup> North American Landslide Conference*, Vail, Colorado, pp. 1837-1847.